

 **Fenner Drives[®]**

CONVEYING & POWER TRANSMISSION SOLUTIONS

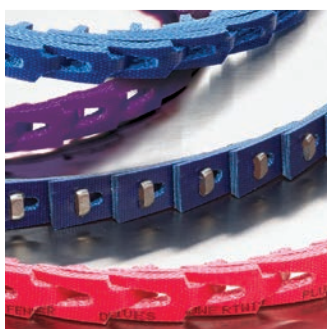
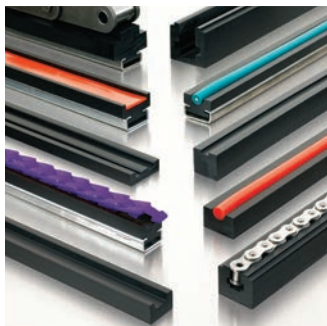

COUNT ON FENNER DRIVES

All over the world, the engineering community turns to Fenner Drives for value-adding, problem solving products for conveying and power transmission applications. Our quality-driven teams design, manufacture and distribute a broad range of sophisticated, reliable components. Fenner Drives has over 100 years of manufacturing, technical and commercial expertise; ISO 9001 certified production facilities in Manheim and Lancaster, PA and Wilmington, NC; warehouse facilities in Lancaster, PA, Wilmington, NC, and Dewsbury, UK; and a global sales team with a presence on six continents.

Fenner Drives is a division of Fenner PLC. With over 5,500 employees worldwide, Fenner PLC is a leading global provider of local, engineered solutions for performance critical applications.



CONVEYING SOLUTIONS. 4

- Belting Selection – Round and V Belting 6 – 7
- Eagle O-Rings. 8
- Fabricated Belts. 8
- Round Belting & Products 8 – 16
- V Belting & Products 17 – 22
- Flat Belting 23
- Eagle Taper Edge Bands 23
- Eagle Welding Kits 24
- Trackstar Guide, Channel & Rails 25
- Chain Accessories. 26 – 28
- T-Max Tensioner/Sprocket Assemblies. 28
- T-Max Chain Tensioners 29
- Engineering Data – Conveying Products 30 – 34
- Material Properties – Conveying Products 35 – 36

POWER TRANSMISSION SOLUTIONS 37

- V Belting & Wedge Belting 38
- T-Max Belt & Chain Tensioners 38 – 40
- PowerMax DriveN Pulleys. 40
- RotoShield Gearbox Torque Limiters 41
- Material Properties – Power Transmission Products 41
- Keyless Locking Devices Selection Assistance. 42 – 43
- Trantorque Keyless Bushings. 44 – 52
- B-LOC Keyless Locking Devices 53 – 66
- Keyless Locking Device Application Examples 67
- Engineering Data – Keyless Locking Devices. 68 – 71
- B-LOC Compression Hubs 72 – 75
- Engineering Data – B-LOC Compression Hubs. 76
- B-LOC Shrink Discs 77 – 78
- B-LOC Split and Half Shrink Discs 79 – 83
- B-LOC Single Taper Shrink Discs 84 – 85
- Engineering Data – B-LOC Shrink Discs 86
- B-LOC WK Rigid Couplings 87
- Engineering Data – B-LOC WK Rigid Couplings. 88 – 89

POWERMAX COMPOSITE SOLUTIONS 90

- PowerMax Pulleys 91 – 92
- PowerMax Carriage Rollers, Mounting Adapters, Pulleys . . 93
- Engineering Data – Pulleys & Idlers 94
- Material Properties – Pulleys & Idlers 94

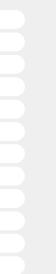



Tango[™]

Tango Conveyor Link Belting

- Install in minutes without dismantling conveyor components – no welding required
- Unaffected by extremes of temperature, water, oils, grease and common solvents
- Whether your application requires reduced contact surface, high grip, abrasion resistance, non-marking, high temperature, oil, and chemical resistance, there's a Fenner Drives link belt to meet your need



EAGLE[®]

Eagle Polyurethane Belting

- Comprehensive range of high quality non-reinforced and reinforced belting in round and V profiles; also available with special top surfaces
- Over 400 FDA compliant products
- Custom design capabilities: special profiles, dual durometer, static dissipative, UV stabilized, tracking features, ridged profiles



Trackstar[®]

Trackstar UHMW Belt & Chain Guides

- Fight friction and reduce costs with long-wearing UHMW belt and chain guides
- Wide range of standard profiles for use in guiding belts, chain and cables
- Available from stock with same-day shipping
- Two-piece guide and channel design simplifies installation and replacement



T-MAX[®]

T-Max Belt and Chain Tensioners

- Spring loaded tensioners automatically take up the slack – decreasing downtime, reducing operating costs and saving energy
- Constructed from high-quality materials for proven durability in harsh environments
- Wide range of tensioners to handle single and multiple strand belt and chain drives

2mm 2.4mm 3mm 3/32" 1/8" 3/16" 1/4" 5/16" 3/8" 10mm 12mm 12.7mm 1/2" 13mm 14mm 15mm 9/16" 16mm 18mm 5/8" 19mm 20mm 3/4"

| | 2mm | 2.4mm | 3mm | 3/32" | 1/8" | 3/16" | 1/4" | 5/16" | 3/8" | 10mm | 12mm | 12.7mm | 1/2" | 13mm | 14mm | 15mm | 9/16" | 16mm | 18mm | 5/8" | 19mm | 20mm | 3/4" | |
|-------------------------------|-----|-------|-----|-------|------|-------|------|-------|------|------|------|--------|------|------|------|------|-------|------|------|------|------|------|------|---|
| Tango™ Link Belting | | | | | | | | ● | | | | | | | ● | | | | | | | | ● | |
| Eagle Blue® 80 EC* | ● | | ● | ● | ● | ● | ● | | ● | ● | | | | | | | | | | | | | | |
| Eagle Clear 80 EC* | ○ | | ○ | ○ | ○ | ○ | ○ | | ○ | ○ | | | | | | | | | | | | | | |
| Eagle Blue 80 MD* | | | | | | ● | | ● | | | | | ● | | ● | | | ● | | | | | | |
| Eagle Opaque 80 | ○ | | ○ | ○ | ○ | ○ | ○ | | ○ | ○ | | | | | | ○ | | | | | | | | |
| Eagle Blue 85* | | | ● | ● | ● | ● | ● | | ● | ● | | | | | | ● | | | | | | | | |
| Eagle Clear 85* | ○ | ○ | ○ | ○ | ○ | ○ | ○ | ○ | | ○ | ○ | ○ | ○ | | ○ | | | ○ | | | | ○ | | |
| Eagle Orange 85* | ● | ● | ● | ● | ● | ● | ● | ● | ● | ● | ● | ● | | | ● | | | ● | | | ● | | | |
| Eagle Orange 89 SureConnect™ | | | | | | | | | ○ | | | ○ | | | ○ | | | | | | ○ | | | |
| Eagle Red 85* | | | | ● | ● | | | | | | | | ● | | | | | | | | | | | |
| Eagle Green 89 | ● | | ● | ● | ● | ● | | ● | ● | | ● | ● | | | | ● | | | ● | | ● | | ● | |
| Eagle Green 89 T | ● | | ● | ● | ● | ● | | ● | ● | ● | | | | | | ● | | | ● | | ● | | ● | |
| Eagle Green 89 T SureConnect™ | | | | | | | | | | ○ | ○ | | | | | ○ | | | ○ | | ○ | | | |
| Eagle Red 90 | ● | | ● | ● | ● | | ● | ● | ● | | ● | ● | ● | ● | | ● | ● | | | | | | | |
| Eagle Beige 95* | | | | | | ○ | | | ○ | | | | | | | ○ | | | | | | | | |
| Eagle Clear 95* | | ○ | ○ | | | ○ | | | ○ | | | | ○ | | ○ | | | ○ | | | | ○ | | |
| Eagle White 40D | | | ○ | ○ | ○ | ○ | | | ○ | | | | | | | ○ | | | ○ | | | | ○ | |
| Eagle Blue 55D | | | | | | | | | | ● | | | | | | ● | | | ● | | | | | |
| Eagle Blue 80 EC QC* | | | | | | ○ | ○ | | ○ | | | | | | | | | | | | | | | |
| Eagle Blue 85 QC* | | | | | | ○ | ○ | | ○ | | | | | | | | | | | | | | | |
| Eagle Clear 85 QC* | | | | | | ○ | ○ | ○ | | ○ | | | ○ | ○ | | | | ○ | | | | | | |
| Eagle Red 85 QC | | | | | | ○ | ○ | | ○ | | | | | | | | | ○ | | | | | | |
| Eagle Yellow 85 QC* | | | | | | ○ | ○ | | ○ | | | | | | | | | ○ | | | | | | |
| Eagle Clear 85 TOR | | | | | | ○ | | | | | | | | | | | | | | | | | | |
| Eagle Orange 85 R* | | | | | | ● | ● | | ● | ● | ● | ● | ● | | ● | ● | | | | | ● | | | |
| Eagle Hyfen 85 R* | | | | | | ● | ● | | ● | ● | | ● | ● | | ● | ● | | ● | ● | | ● | | | |
| Eagle Green 89 R | | | | | | ● | ● | | ● | ● | | ● | ● | | ● | ● | | ● | ● | | ● | | | |
| Eagle Green 89 RT | | | | | | ● | ● | | ● | ● | | ● | ● | | ● | ● | | ● | ● | | ● | | | |
| Eagle Beige 95 R* | | | | | | | | | ○ | | | | | | | ○ | | | | | | | | |
| Eagle Can Cable† | | | | | | | | | | ● | | | | | | | | | | | | | | |
| Eagle Fabricated Belts | ● | ● | ● | ● | ● | ● | ● | ● | ● | ● | ● | ● | ● | ● | ● | ● | ● | ● | ● | ● | ● | ● | ● | ● |

Abbreviation Key

| | |
|------|-----------------------------|
| CXF | Co-extruded Flat |
| CXR | Co-extruded Ribbed |
| EC | Regulation (EC) 1935/2004 |
| LCF | Low Coefficient of Friction |
| MD | Metal Detectable |
| PU | PolyUrethane |
| PVC | PolyVinyl Chloride |
| QC | Quick-Connect |
| R | Reinforced |
| RCS | Reduced Contact Surface |
| RSGT | Reinforced SuperGrip Top |
| RT | Reinforced Textured |
| SGT | SuperGrip Top |
| T | Textured |
| TOR | Twisted O-Rings |
| TPE | ThermoPlastic Elastomer |

* These belts are FDA compliant (unless cogged).

† Can Cable available in Red 50D LCF, Blue 55D, Blue 55D Aramid, Natural 55D, Green 63D, and Natural 63D.

‡ Eagle Ivory 85 SGT and RSGT available with PVC, PU or TPE top surface.

¶ ISO 1813:1998 inspected and certified by Fenner Drives.

- Not all product in-stock, please call for availability.
- Some diameters and cross sections may be subject to minimum orders. Dimensions are for reference only.
- Flat belting available in Eagle Orange 85. Additional cross sections, colors, and durometers are available.
- Contact Applications Engineering at AE@fennerdrives.com for design assistance.

| 6mm x 4mm | 8mm x 5mm | 10mm x 4mm T-Top | 3L | 3L T-Top | 3L Crown-Top | 3L Twin | Z/10 | A/13 | AA | A Twin | A/13 Lo-Ridge-Top | A/13 Ridge-Top | A/13 Hi-Ridge-Top | B/17 | BB | B/17 Ribbed | B/17 Wing-Top | B/17 Ridge-Top | C/22 | C/22 Ribbed | C/22 Ridge-Top | D/32 | D/32 Ribbed | | |
|-----------|-----------|------------------|----|----------|--------------|---------|------|------|----|--------|-------------------|----------------|-------------------|------|----|-------------|---------------|----------------|------|-------------|----------------|------|-------------|---------------------|-------------------------------------|
| | | | | | | | | ▼ | | | | | | ▼ | | | | | | | | | | Tango™ Link Belting | |
| | | | | | | | | ▼ | | | | | | ▼ | | | | | | | | | | | Tango Bridge Top™ |
| | | | | | | | | ▼ | | | | | | ▼ | | | | | | | | | | | Tango SuperGrip Top PU |
| | | | | | | | | ▼ | | | | | | ▼ | | | | | | | | | | | Tango SuperGrip Top PVC |
| | | | | | | | | ▼ | | | | | | ▼ | | | | | | | | | | | Tango RCS |
| | | | | | | | | ▼ | | | | | | ▼ | | | | | | | | | | | Tango Friction Top® |
| | | | | | | | | ▼ | | | | | | ▼ | | | | | | | | | | | PowerTwist® Antistatic [†] |
| | | | | | | | | ▼ | | | | | | ▼ | | | | | | | | | | | PowerTwist Roller Drive™ |
| ▼ | ▼ | ▼ | | | | | ▼ | ▼ | | | | | | ▼ | | | | | | | | | | | Eagle® Blue 80 EC* |
| ▼ | ▼ | ▼ | | | | | ▼ | ▼ | | | | | | ▼ | | | | | | | | | | | Eagle Clear 80 EC* |
| ▼ | ▼ | ▼ | | | | | ▼ | ▼ | | | | | | ▼ | | | | | | | | | | | Eagle Blue 80 MD* |
| ▼ | ▼ | ▼ | | | | | ▼ | ▼ | | | | | | ▼ | | | | | | | | | | | Eagle Opaque 80 |
| ▼ | ▼ | ▼ | | | | | ▼ | ▼ | | | | | | ▼ | | | | | | | | | | | Eagle Blue 85* |
| ▼ | ▼ | ▼ | | | | | ▼ | ▼ | | | | | | ▼ | | | | | | | | | | | Eagle Clear 85* |
| ▼ | ▼ | ▼ | | | | | ▼ | ▼ | | | | | | ▼ | | | | | | | | | | | Eagle Ivory 85 |
| ▼ | ▼ | ▼ | | | | | ▼ | ▼ | | | | | | ▼ | | | | | | | | | | | Eagle Orange 85* |
| ▼ | ▼ | ▼ | | | | | ▼ | ▼ | | | | | | ▼ | | | | | | | | | | | Eagle Red 85* |
| ▼ | ▼ | ▼ | | | | | ▼ | ▼ | | | | | | ▼ | | | | | | | | | | | Eagle Green 89 |
| ▼ | ▼ | ▼ | | | | | ▼ | ▼ | | | | | | ▼ | | | | | | | | | | | Eagle Red 90 |
| ▼ | ▼ | ▼ | | | | | ▼ | ▼ | | | | | | ▼ | | | | | | | | | | | Eagle Beige 95* |
| ▼ | ▼ | ▼ | | | | | ▼ | ▼ | | | | | | ▼ | | | | | | | | | | | Eagle Clear 95* |
| ▼ | ▼ | ▼ | | | | | ▼ | ▼ | | | | | | ▼ | | | | | | | | | | | Eagle White 40D |
| ▼ | ▼ | ▼ | | | | | ▼ | ▼ | | | | | | ▼ | | | | | | | | | | | Eagle Blue 55D |
| ▼ | ▼ | ▼ | | | | | ▼ | ▼ | | | | | | ▼ | | | | | | | | | | | Eagle Red 85 CXF |
| ▼ | ▼ | ▼ | | | | | ▼ | ▼ | | | | | | ▼ | | | | | | | | | | | Eagle Ivory 85 SGT* |
| ▼ | ▼ | ▼ | | | | | ▼ | ▼ | | | | | | ▼ | | | | | | | | | | | Eagle Green 89 SGT PVC |
| ▼ | ▼ | ▼ | | | | | ▼ | ▼ | | | | | | ▼ | | | | | | | | | | | Eagle Red 90 SGT PVC |
| ▼ | ▼ | ▼ | | | | | ▼ | ▼ | | | | | | ▼ | | | | | | | | | | | Eagle White 40DSGT PVC |
| ▼ | ▼ | ▼ | | | | | ▼ | ▼ | | | | | | ▼ | | | | | | | | | | | Eagle Opaque 80 R |
| ▼ | ▼ | ▼ | | | | | ▼ | ▼ | | | | | | ▼ | | | | | | | | | | | Eagle Orange 85 R* |
| ▼ | ▼ | ▼ | | | | | ▼ | ▼ | | | | | | ▼ | | | | | | | | | | | Eagle Hyfen 85 R* |
| ▼ | ▼ | ▼ | | | | | ▼ | ▼ | | | | | | ▼ | | | | | | | | | | | Eagle Ivory 85 R |
| ▼ | ▼ | ▼ | | | | | ▼ | ▼ | | | | | | ▼ | | | | | | | | | | | Eagle Green 89 R |
| ▼ | ▼ | ▼ | | | | | ▼ | ▼ | | | | | | ▼ | | | | | | | | | | | Eagle Beige 95 R* |
| ▼ | ▼ | ▼ | | | | | ▼ | ▼ | | | | | | ▼ | | | | | | | | | | | Eagle Hyfen 95 R* |
| ▼ | ▼ | ▼ | | | | | ▼ | ▼ | | | | | | ▼ | | | | | | | | | | | Eagle Hyfen 85 CXF/CXR |
| ▼ | ▼ | ▼ | | | | | ▼ | ▼ | | | | | | ▼ | | | | | | | | | | | Eagle Ivory 85 RSGT [‡] |
| ▼ | ▼ | ▼ | | | | | ▼ | ▼ | | | | | | ▼ | | | | | | | | | | | Eagle Fabricated Belts |

Link Belting

Non-Reinforced Belting

Reinforced Belting

Eagle® O-Rings

- O-Rings for line shaft, live roller and motion transfer conveyors
- High coefficient of friction
- Elastic with excellent memory
- Popular 1/8", 3/16", 1/4", 5mm and 6mm sizes in stock
- Contact Fenner Drives for part numbers

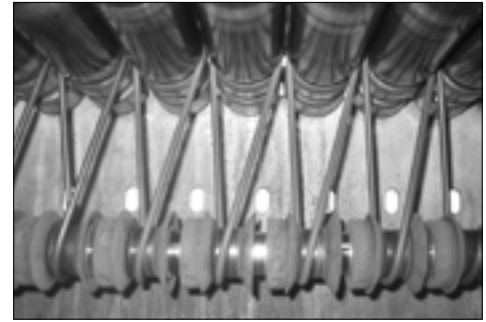

Twisted O-Rings

- Twisted O-Rings are an ideal fast fit solution for live roller conveyors
- Twisted loop construction packaged with metal hooks. Plastic hooks also available
- No need to dismantle drive components

| TWISTED O-RINGS | | |
|--------------------|-------------|-----------------|
| Material and Color | Part Number | Dimensions |
| Eagle Clear 85 | 5050003 | 3/16" x 6" |
| Eagle Clear 85 | 5050011 | 3/16" x 10" |
| Eagle Clear 85 | 5050015 | 3/16" x 10-1/2" |
| Eagle Clear 85 | 5050012 | 3/16" x 11" |
| Eagle Clear 85 | 5050911 | 3/16" x 11-1/2" |
| Eagle Clear 85 | 5050016 | 3/16" x 12" |
| Eagle Clear 85 | 5050005 | 3/16" x 12-1/2" |
| Eagle Clear 85 | 5050002 | 3/16" x 12-3/4" |
| Eagle Clear 85 | 5050006 | 3/16" x 12-7/8" |
| Eagle Clear 85 | 5050007 | 3/16" x 13" |
| Eagle Clear 85 | 5050017 | 3/16" x 13-1/4" |
| Eagle Clear 85 | 5050009 | 3/16" x 13-1/2" |
| Eagle Clear 85 | 5050014 | 3/16" x 13-3/4" |
| Eagle Clear 85 | 5050008 | 3/16" x 14" |
| Eagle Clear 85 | 5050010 | 3/16" x 14-1/2" |



Eagle Twisted O-Rings easily installed without dismantling line shaft.
50 pieces per box, packaged with metal hooks. Plastic hooks also available.

Eagle Fabricated Belts

Let us do the work for you and take the hassle out of fabricating your own endless belts

- Available in all Eagle Belting colors and durometers (except Can Cable)
- Rapid order turnaround

2mm, 3/32", 3mm, 1/8" Round Cross Sections Round Belting



| NON-REINFORCED Material and Color | Part Number* | Dimensions Ø | | Minimum Pulley Ø | | Working Load @ Percent Tension | | | | | | | | Weight | |
|--------------------------------------|--------------|--------------|------|------------------|------|--------------------------------|------|--------|------|-----|------|-----|------|--------|-------|
| | | (in) | (mm) | (in) | (mm) | 4% (N) | | 6% (N) | | 8% | | 10% | | lbs/ft | kg/m |
| Eagle Blue 80 EC | 4928000 | | 2 | 0.55 | 14 | 0.1 | 0.7 | 0.2 | 1 | 0.3 | 1.4 | 0.4 | 1.7 | 0.002 | 0.004 |
| Eagle Clear 80 EC | 4927000 | | 2 | 0.55 | 14 | 0.1 | 0.7 | 0.2 | 1 | 0.3 | 1.4 | 0.4 | 1.7 | 0.002 | 0.004 |
| Eagle Opaque 80 | L04OP802M | | 2 | 0.55 | 14 | 0.2 | 0.9 | 0.4 | 1.6 | 0.5 | 2.2 | 0.6 | 2.7 | 0.003 | 0.004 |
| Eagle Orange 85 | L04OG852M | | 2 | 0.63 | 16 | 0.2 | 0.9 | 0.3 | 1.3 | 0.4 | 1.8 | 0.5 | 2.2 | 0.003 | 0.004 |
| Eagle Clear 85 | L04C852M | | 2 | 0.63 | 16 | 0.2 | 0.9 | 0.3 | 1.3 | 0.4 | 1.8 | 0.5 | 2.2 | 0.003 | 0.004 |
| Eagle Green 89 | 4905402 | | 2 | 0.71 | 18 | 0.3 | 1.4 | 0.5 | 2.4 | 0.7 | 3.2 | 0.9 | 4 | 0.003 | 0.004 |
| Eagle Green 89 Textured | 4905302 | | 2 | 0.71 | 18 | 0.2 | 1 | 0.4 | 1.7 | 0.5 | 2.3 | 0.7 | 2.9 | 0.003 | 0.004 |
| Eagle Red 90 | 4940017 | | 2 | 0.79 | 20 | 1.1 | 4.7 | 1.5 | 6.8 | 1.9 | 8.5 | 2.2 | 10 | 0.003 | 0.004 |
| Eagle Orange 85 | 1032003 | 3/32 | | 0.75 | 19 | 0.3 | 1.2 | 0.4 | 1.9 | 0.6 | 2.5 | 0.7 | 3.1 | 0.004 | 0.005 |
| Eagle Clear 85 | 4908003 | 3/32 | | 0.75 | 19 | 0.3 | 1.2 | 0.4 | 1.9 | 0.6 | 2.5 | 0.7 | 3.1 | 0.004 | 0.005 |
| Eagle Clear 95 | 4907003 | 3/32 | | 0.94 | 24 | 0.5 | 2.3 | 0.8 | 3.4 | 1 | 4.3 | 1.2 | 5.1 | 0.004 | 0.005 |
| Eagle Orange 85 | 1032004 | 1/8 | | 1 | 25 | 0.5 | 2.2 | 0.7 | 3.3 | 1 | 4.4 | 1.2 | 5.5 | 0.006 | 0.01 |
| Eagle Clear 85 | 4908006 | 1/8 | | 1 | 25 | 0.5 | 2.2 | 0.7 | 3.3 | 1 | 4.4 | 1.2 | 5.5 | 0.006 | 0.01 |
| Eagle Clear 95 | 4907006 | 1/8 | | 1.25 | 32 | 0.9 | 4 | 1.3 | 6 | 1.7 | 7.7 | 2.1 | 9.1 | 0.007 | 0.01 |
| Eagle Blue 80 EC | 4928001 | | 3 | 0.83 | 21 | 0.4 | 1.7 | 0.6 | 2.5 | 0.8 | 3.5 | 1 | 4.3 | 0.005 | 0.008 |
| Eagle Clear 80 EC | 4927001 | | 3 | 0.83 | 21 | 0.4 | 1.7 | 0.6 | 2.5 | 0.8 | 3.5 | 1 | 4.3 | 0.005 | 0.008 |
| Eagle Opaque 80 | L04OP803M | | 3 | 0.83 | 21 | 0.5 | 2.1 | 0.8 | 3.5 | 1.1 | 4.9 | 1.4 | 6.2 | 0.006 | 0.009 |
| Eagle Orange 85 | L04OG853M | | 3 | 0.94 | 24 | 0.4 | 1.9 | 0.7 | 3 | 0.9 | 4 | 1.1 | 4.9 | 0.006 | 0.009 |
| Eagle Clear 85 | L04C853M | | 3 | 0.94 | 24 | 0.4 | 1.9 | 0.7 | 3 | 0.9 | 4 | 1.1 | 4.9 | 0.006 | 0.009 |
| Eagle Blue 85 | L04BL853M | | 3 | 0.94 | 24 | 0.4 | 1.9 | 0.7 | 3 | 0.9 | 4 | 1.1 | 4.9 | 0.006 | 0.009 |
| Eagle Green 89 | L04G893MS | | 3 | 1.06 | 27 | 0.7 | 3.2 | 1.2 | 5.2 | 1.6 | 7.2 | 2 | 9 | 0.006 | 0.009 |
| Eagle Green 89 Textured | 4905303 | | 3 | 1.06 | 27 | 0.5 | 2.3 | 0.9 | 3.8 | 1.2 | 5.2 | 1.5 | 6.5 | 0.006 | 0.009 |
| Eagle Red 90 | 4940020 | | 3 | 1.18 | 30 | 2.4 | 10.5 | 3.4 | 15.1 | 4.3 | 19 | 5 | 22.2 | 0.006 | 0.009 |
| Eagle White 40D | L04BY403M | | 3 | 1.42 | 36 | 1.9 | 8.3 | 2.9 | 12.8 | 3.8 | 16.8 | 4.5 | 20.2 | 0.006 | 0.008 |

* Standard package length 100' / 30.5m
Dimensions are for reference only.

4mm, 5mm, 3/16" Round Cross Sections Round Belting



| NON-REINFORCED | | | | Working Load @ Percent Tension | | | | | | | | | | Weight | |
|-------------------------|--------------|------------------------|----------------------------|--------------------------------|------|--------------|------|--------------|------|---------------|------|--------|-------|--------|--|
| Material and Color | Part Number* | Dimensions Ø (in) (mm) | Minimum Pulley Ø (in) (mm) | 4% (lbs) (N) | | 6% (lbs) (N) | | 8% (lbs) (N) | | 10% (lbs) (N) | | lbs/ft | kg/m | | |
| Eagle® Blue 80 EC | 4928002 | 4 | 1.1 28 | 0.6 | 2.8 | 0.9 | 4.2 | 1.3 | 5.6 | 1.5 | 6.7 | 0.009 | 0.014 | | |
| Eagle Clear 80 EC | 4927002 | 4 | 1.1 28 | 0.6 | 2.8 | 0.9 | 4.2 | 1.3 | 5.6 | 1.5 | 6.7 | 0.009 | 0.014 | | |
| Eagle Opaque 80 | L04OP804 | 4 | 1.1 28 | 0.8 | 3.7 | 1.4 | 6.2 | 2 | 8.7 | 2.5 | 11 | 0.01 | 0.015 | | |
| Eagle Orange 85 | L04OG854 | 4 | 1.26 32 | 0.8 | 3.4 | 1.2 | 5.3 | 1.6 | 7 | 1.9 | 8.6 | 0.01 | 0.015 | | |
| Eagle Clear 85 | L04C854 | 4 | 1.26 32 | 0.8 | 3.4 | 1.2 | 5.3 | 1.6 | 7 | 1.9 | 8.6 | 0.01 | 0.015 | | |
| Eagle Red 85 | L04R8504 | 4 | 1.26 32 | 0.8 | 3.4 | 1.2 | 5.3 | 1.6 | 7 | 2 | 8.7 | 0.01 | 0.015 | | |
| Eagle Blue 85 | L04BL854 | 4 | 1.26 32 | 0.8 | 3.4 | 1.2 | 5.3 | 1.6 | 7 | 2 | 8.7 | 0.01 | 0.015 | | |
| Eagle Green 89 | 4905404 | 4 | 1.42 36 | 1.3 | 5.7 | 2.1 | 9.3 | 2.9 | 12.8 | 3.6 | 16 | 0.01 | 0.015 | | |
| Eagle Green 89 Textured | 4905304 | 4 | 1.42 36 | 0.9 | 4.1 | 1.5 | 6.8 | 2.1 | 9.3 | 2.6 | 11.6 | 0.01 | 0.015 | | |
| Eagle Red 90 | 4940021 | 4 | 1.57 40 | 4.2 | 18.6 | 6 | 26.8 | 7.6 | 33.8 | 8.9 | 39.5 | 0.01 | 0.015 | | |
| Eagle White 40D | L04BY404 | 4 | 1.89 48 | 3.3 | 14.8 | 5.1 | 22.8 | 6.7 | 29.8 | 8.1 | 36 | 0.01 | 0.015 | | |
| Eagle Blue 80 MD | 4941100 | 3/16 | 1.31 33 | 0.8 | 3.5 | 1.2 | 5.4 | 1.6 | 7 | 1.9 | 8.6 | 0.013 | 0.02 | | |
| Eagle Orange 85 | 1032006 | 3/16 | 1.5 38 | 1.1 | 4.9 | 1.7 | 7.5 | 2.2 | 10 | 2.8 | 12.3 | 0.014 | 0.021 | | |
| Eagle Clear 85 | 4908009 | 3/16 | 1.5 38 | 1.1 | 4.9 | 1.7 | 7.5 | 2.2 | 10 | 2.8 | 12.3 | 0.014 | 0.021 | | |
| Eagle Red 90 | 4940022 | 3/16 | 1.88 48 | 6 | 26.5 | 8.6 | 38.2 | 10.8 | 48.1 | 12.6 | 56.2 | 0.014 | 0.022 | | |
| Eagle Clear 95 | 4907009 | 3/16 | 1.88 48 | 2 | 9.1 | 3 | 13.5 | 3.9 | 17.3 | 4.6 | 20.6 | 0.015 | 0.022 | | |
| Eagle Clear 85 QC | 4934009 | .188 x .080† | 1.5 38 | 0.5 | 2 | 0.7 | 3.1 | 0.9 | 4.2 | 1.2 | 5.2 | 0.012 | 0.018 | | |
| Eagle Yellow 85 QC | 4934021 | .188 x .080† | 1.5 38 | 0.5 | 2 | 0.7 | 3.1 | 0.9 | 4.2 | 1.2 | 5.2 | 0.012 | 0.018 | | |
| Eagle Blue 80 EC | 4928003 | 5 | 1.38 35 | 0.9 | 4.2 | 1.4 | 6.3 | 1.9 | 8.4 | 2.4 | 10.6 | 0.015 | 0.022 | | |
| Eagle Clear 80 EC | 4927003 | 5 | 1.38 35 | 0.9 | 4.2 | 1.4 | 6.3 | 1.9 | 8.4 | 2.4 | 10.6 | 0.015 | 0.022 | | |
| Eagle Opaque 80 | L04OP805M | 5 | 1.38 35 | 1.3 | 5.7 | 2.2 | 9.7 | 3.1 | 13.6 | 3.9 | 17.2 | 0.016 | 0.024 | | |
| Eagle Orange 85 | 4940100 | 5 | 1.57 40 | 1.2 | 5.4 | 1.9 | 8.3 | 2.5 | 11 | 3.1 | 13.6 | 0.016 | 0.024 | | |
| Eagle Clear 85 | L04C855M | 5 | 1.57 40 | 1.2 | 5.3 | 1.9 | 8.2 | 2.5 | 11 | 3 | 13.5 | 0.016 | 0.024 | | |
| Eagle Red 85 | L04R855 | 5 | 1.57 40 | 1.2 | 5.3 | 1.9 | 8.2 | 2.5 | 11 | 3 | 13.5 | 0.016 | 0.024 | | |
| Eagle Blue 85 | L04BL855M | 5 | 1.57 40 | 1.2 | 5.3 | 1.9 | 8.2 | 2.5 | 11 | 3 | 13.5 | 0.016 | 0.024 | | |
| Eagle Green 89 | 4905405 | 5 | 1.77 45 | 2 | 8.9 | 3.3 | 14.6 | 4.5 | 20.1 | 5.6 | 25.1 | 0.016 | 0.023 | | |
| Eagle Green 89 Textured | 4905305 | 5 | 1.77 45 | 1.5 | 6.5 | 2.4 | 10.6 | 3.3 | 14.6 | 4.1 | 18.2 | 0.016 | 0.023 | | |
| Eagle Red 90 | L04R9005M | 5 | 1.97 50 | 6 | 26.5 | 8.6 | 38.2 | 10.8 | 48.1 | 12.6 | 56.2 | 0.014 | 0.022 | | |
| Eagle Beige 95 | L04BE955M | 5 | 1.97 50 | 5.3 | 23.6 | 7.5 | 33.4 | 9.4 | 41.8 | 11 | 48.8 | 0.016 | 0.024 | | |
| Eagle White 40D | L04BY405M | 5 | 2.36 60 | 5.2 | 23.1 | 8 | 35.5 | 10.5 | 46.6 | 12.6 | 56.2 | 0.015 | 0.023 | | |
| Eagle Blue 80 EC QC | 4928020 | 5 x 2† | 1.38 35 | 0.4 | 1.8 | 0.6 | 2.8 | 0.8 | 3.7 | 1 | 4.6 | 0.012 | 0.018 | | |
| Eagle Clear 85 QC | L04QC855M | 5 x 2† | 1.57 40 | 0.5 | 2.3 | 0.8 | 3.5 | 1.1 | 4.7 | 1.3 | 5.8 | 0.013 | 0.02 | | |
| Eagle Red 85 QC | L04QR855M | 5 x 2† | 1.57 40 | 0.5 | 2.3 | 0.8 | 3.5 | 1.1 | 4.7 | 1.3 | 5.8 | 0.013 | 0.02 | | |
| Eagle Blue 85 QC | L04QB855M | 5 x 2† | 1.38 35 | 0.5 | 2.3 | 0.8 | 3.5 | 1.1 | 4.7 | 1.3 | 5.8 | 0.013 | 0.02 | | |
| QC Connectors | 4935009 | 25/pack | | | | | | | | | | | | | |
| REINFORCED | | | | Working Load @ Percent Tension | | | | | | | | Weight | | | |
| Material and Color | Part Number* | Dimensions Ø (in) (mm) | Minimum Pulley Ø (in) (mm) | 1% (lbs) (N) | | 2% (lbs) (N) | | 3% (lbs) (N) | | 4% (lbs) (N) | | lbs/ft | kg/m | | |
| Eagle Hyfen 85 | 5218009 | 3/16 | 2.06 52 | 2.8 | 12.5 | 6.8 | 30.2 | 11.2 | 49.8 | 15.5 | 68.9 | 0.014 | 0.021 | | |
| Eagle Green 89 | L04G895MRS | 5 | 1.97 50 | 1.7 | 7.4 | 5 | 22.2 | 10.2 | 45.4 | 15.7 | 70.1 | 0.016 | 0.023 | | |
| Eagle Green 89 Textured | 4940056 | 5 | 1.97 50 | 2.3 | 10.2 | 6.9 | 30.5 | 14 | 62.5 | 21.7 | 96.3 | 0.016 | 0.023 | | |

Trackstar® Round Belt Guides

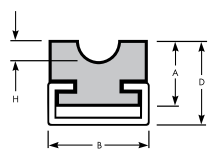

| Belt Guide w/ Mounting Channel | Part Numbers | | | | Channel Type | A | B | D | H |
|--------------------------------|--------------------|-------------------------|------------------|-----------|--------------|------|------|-----|------|
| | Galvanized Channel | Stainless Steel Channel | Aluminum Channel | UHMW Only | | | | | |
| | GB1006-3G | GB1006-3S | GB1006-3A | GB1006 | C3 | 0.59 | 0.79 | 0.8 | 0.13 |

Trackstar Guides are stocked in North America and supplied in 120" standard lengths. Subject to a minimum order quantity. Dimensions are in inches and are for reference only.

* Standard package length 100' / 30.5m

† QC dimensions are shown O.D x I.D. (O.D. is the outer diameter of the belt. I.D. is the inner diameter of the belt.) Dimensions are for reference only.

6mm, 1/4" Round Cross Sections

Round Belting



Round

| NON-REINFORCED | Part Number* | Dimensions Ø (in) (mm) | | Minimum Pulley Ø (in) (mm) | | Working Load @ Percent Tension | | | | | | | | Weight | |
|-------------------------|--------------|--------------------------|------|----------------------------|-----|--------------------------------|------|--------|------|--------|------|---------|-------|--------|-------|
| | | | | | | 4% (N) | | 6% (N) | | 8% (N) | | 10% (N) | | lbs/ft | kg/m |
| Eagle® Blue 80 EC | 4928004 | 6 | 1.65 | 42 | 1.3 | 5.9 | 2.1 | 9.1 | 2.8 | 12.3 | 3.4 | 15.2 | 0.021 | 0.032 | |
| Eagle Clear 80 EC | 4927004 | 6 | 1.65 | 42 | 1.3 | 5.9 | 2.1 | 9.1 | 2.8 | 12.3 | 3.4 | 15.2 | 0.021 | 0.032 | |
| Eagle Opaque 80 | L04OP806M | 6 | 1.65 | 42 | 1.9 | 8.2 | 3.2 | 14 | 4.4 | 19.6 | 5.6 | 24.7 | 0.023 | 0.034 | |
| Eagle Orange 85 | L04OG856M | 6 | 1.89 | 48 | 1.7 | 7.7 | 2.7 | 11.8 | 3.5 | 15.8 | 4.4 | 19.4 | 0.023 | 0.034 | |
| Eagle Clear 85 | L04C856M | 6 | 1.89 | 48 | 1.7 | 7.7 | 2.7 | 11.8 | 3.5 | 15.8 | 4.4 | 19.4 | 0.023 | 0.034 | |
| Eagle Blue 85 | L04BL856M | 6 | 1.89 | 48 | 1.7 | 7.7 | 2.7 | 11.9 | 3.6 | 15.8 | 4.4 | 19.5 | 0.023 | 0.034 | |
| Eagle Green 89 | 4905406 | 6 | 2.13 | 54 | 2.9 | 12.8 | 4.7 | 21 | 6.5 | 28.9 | 8.1 | 36.1 | 0.023 | 0.034 | |
| Eagle Green 89 Textured | 4905306 | 6 | 2.13 | 54 | 2.1 | 9.3 | 3.4 | 15.3 | 4.7 | 21 | 5.9 | 26.2 | 0.023 | 0.034 | |
| Eagle White 40D | L04BY406M | 6 | 2.83 | 72 | 7.5 | 33.3 | 11.5 | 51.2 | 15.1 | 67.1 | 18.2 | 80.9 | 0.022 | 0.033 | |
| Eagle Blue 80 EC QC | 4928021 | 6 × 2.5 [†] | 1.65 | 42 | 0.6 | 2.5 | 0.9 | 3.9 | 1.2 | 5.3 | 1.5 | 6.6 | 0.018 | 0.026 | |
| Eagle Clear 85 QC | L04QC856M | 6 × 2.5 [†] | 1.89 | 48 | 0.7 | 3.2 | 1.1 | 5 | 1.5 | 6.7 | 1.9 | 8.3 | 0.019 | 0.028 | |
| Eagle Red 85 QC | L04QR856M | 6 × 2.5 [†] | 1.89 | 48 | 0.7 | 3.2 | 1.1 | 5 | 1.5 | 6.7 | 1.9 | 8.3 | 0.019 | 0.028 | |
| Eagle Blue 85 QC | L04QB856M | 6 × 2.5 [†] | 1.89 | 48 | 0.7 | 3.2 | 1.1 | 5 | 1.5 | 6.7 | 1.9 | 8.3 | 0.019 | 0.028 | |
| Eagle Blue 80 MD | 4941101 | 1/4 | 6.3 | 1.75 | 44 | 1.3 | 6 | 2.1 | 9.2 | 2.8 | 12.3 | 3.4 | 15.3 | 0.024 | 0.035 |
| Eagle Opaque 80 | 4940003 | 1/4 | 6.3 | 1.75 | 44 | 2.1 | 9.2 | 3.5 | 15.7 | 4.9 | 22 | 6.2 | 27.7 | 0.026 | 0.039 |
| Eagle Orange 85 | 1032008 | 1/4 | 6.3 | 2 | 51 | 1.9 | 8.6 | 3 | 13.3 | 4 | 17.7 | 4.9 | 21.9 | 0.026 | 0.038 |
| Eagle Clear 85 | 4908012 | 1/4 | 6.3 | 2 | 51 | 1.9 | 8.6 | 3 | 13.3 | 4 | 17.7 | 4.9 | 21.9 | 0.026 | 0.038 |
| Eagle Red 90 | 4940023 | 1/4 | 6.3 | 2.5 | 64 | 10.6 | 47.2 | 15.3 | 67.9 | 19.2 | 85.5 | 22.5 | 100 | 0.026 | 0.038 |
| Eagle Clear 95 | 4907012 | 1/4 | 6.3 | 2.5 | 64 | 3.6 | 16.1 | 5.4 | 24 | 6.9 | 30.8 | 8.2 | 36.6 | 0.026 | 0.039 |
| Eagle Clear 85 QC | 4934012 | .250 × .098 [†] | 2 | 51 | 0.8 | 3.7 | 1.3 | 5.7 | 1.7 | 7.7 | 2.1 | 9.5 | 0.022 | 0.032 | |
| Eagle Yellow 85 QC | 4934022 | .250 × .098 [†] | 2 | 51 | 0.8 | 3.7 | 1.3 | 5.7 | 1.7 | 7.7 | 2.1 | 9.5 | 0.022 | 0.032 | |
| Eagle Blue 80 EC | 4928005 | 1/4 | 6.3 | 1.74 | 44 | 1.5 | 6.6 | 2.3 | 10.2 | 3.1 | 13.7 | 3.8 | 17 | 0.023 | 0.035 |
| Eagle Blue 85 | L04BL856.3 | 1/4 | 6.3 | 2 | 51 | 1.9 | 8.6 | 3 | 13.3 | 4 | 17.7 | 4.9 | 21.8 | 0.025 | 0.037 |
| QC Connectors | L04CON6S | 25/pack | | | | | | | | | | | | | |

| REINFORCED | Part Number* | Dimensions Ø (in) (mm) | | Minimum Pulley Ø (in) (mm) | | Working Load @ Percent Tension | | | | | | | | Weight | |
|-------------------------|--------------|------------------------|------|----------------------------|-----|--------------------------------|------|--------|------|--------|------|--------|-------|--------|-------|
| | | | | | | 1% (N) | | 2% (N) | | 3% (N) | | 4% (N) | | lbs/ft | kg/m |
| Eagle Orange 85 | L04OG856MR | 6 | 2.36 | 60 | 0.7 | 3.2 | 2.5 | 11 | 4.8 | 21.5 | 6.9 | 30.8 | 0.023 | 0.034 | |
| Eagle Green 89 | L04G896MSR | 6 | 2.36 | 60 | 2.4 | 10.6 | 7.2 | 32 | 14.7 | 65.5 | 22.7 | 100.9 | 0.023 | 0.034 | |
| Eagle Green 89 Textured | 4940057 | 6 | 2.36 | 60 | 3.3 | 14.6 | 9.9 | 43.9 | 20.2 | 90 | 31.2 | 138.8 | 0.023 | 0.034 | |
| Eagle Orange 85 | 4940058 | 1/4 | 6.3 | 2.5 | 64 | 0.8 | 3.6 | 2.8 | 12.3 | 5.4 | 24.1 | 7.8 | 34.6 | 0.026 | 0.038 |
| Eagle Hyfen 85 | 5218012 | 1/4 | 6.3 | 2.75 | 70 | 3.7 | 16.5 | 12.4 | 55.2 | 20 | 89 | 27.8 | 123.7 | 0.026 | 0.038 |

Trackstar® Round Belt Guides

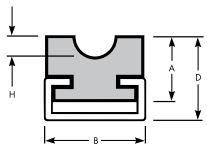

| Belt Guide w/ Mounting Channel | Part Numbers | | | | Channel Type | A | B | D | H |
|--------------------------------|--------------------|-------------------------|------------------|-----------|--------------|------|------|-----|------|
| | Galvanized Channel | Stainless Steel Channel | Aluminum Channel | UHMW Only | | | | | |
| | GB1000-3G | GB1000-3S | GB1000-3A | GB1000 | C3 | 0.59 | 0.79 | 0.8 | 0.16 |

Trackstar Guides are stocked in North America and supplied in 120" standard lengths. Subject to a minimum order quantity. Dimensions are in inches and are for reference only.

* Standard package length 100' / 30.5m

† QC dimensions are shown O.D x I.D. (O.D. is the outer diameter of the belt. I.D. is the inner diameter of the belt). Dimensions are for reference only.

7mm, 8mm, 5/16" Round Cross Sections



Round

Round Link Belting

| LINK BELTING | Part Number | | Cross Section | Minimum Pulley Ø | | Max Product Weight w/Idlers | | Max Product Weight w/UHMW | |
|----------------|-------------|---------|---------------|------------------|------|-----------------------------|------|---------------------------|------|
| | 25' | 10m | | (in) | (mm) | (lbs) | (kg) | (lbs) | (kg) |
| Tango Belting | | 0470133 | 8mm | 2.0 | 51 | 74 | 33 | 25 | 11 |
| Tango™ Belting | 0470125 | | 5/16" | 2.0 | 51 | 74 | 33 | 25 | 11 |

Round Belting

| NON-REINFORCED | Part Number* | Dimensions Ø (in) (mm) | Minimum Pulley Ø (in) (mm) | Working Load @ Percent Tension | | | | | | | | Weight | | | |
|-------------------------|--------------|------------------------|----------------------------|--------------------------------|-----|-------|------|-------|-------|-------|-------|--------|-------|-------|-------|
| | | | | 4% | | 6% | | 8% | | 10% | | lbs/ft | kg/m | | |
| Material and Color | | | | (lbs) | (N) | (lbs) | (N) | (lbs) | (N) | (lbs) | (N) | | | | |
| Eagle® Orange 85 | L04OG857M | | 7 | 2.2 | 56 | 2.4 | 10.5 | 3.6 | 16.2 | 4.8 | 21.6 | 6 | 26.6 | 0.031 | 0.046 |
| Eagle Clear 85 | L04C857M | | 7 | 2.2 | 56 | 2.4 | 10.5 | 3.6 | 16.2 | 4.8 | 21.6 | 6 | 26.6 | 0.031 | 0.046 |
| Eagle Green 89 | 4999637 | | 7 | 2.48 | 63 | 3.9 | 17.4 | 6.4 | 28.6 | 8.8 | 39.3 | 11 | 49.1 | 0.031 | 0.046 |
| Eagle Green 89 Textured | 4950307 | | 7 | 2.48 | 63 | 2.9 | 12.7 | 4.7 | 20.9 | 6.4 | 28.7 | 8.1 | 35.8 | 0.031 | 0.046 |
| Eagle Red 90 | L04R907 | | 7 | 2.76 | 70 | 12.9 | 57.4 | 18.6 | 82.7 | 23.4 | 104.1 | 27.4 | 121.8 | 0.031 | 0.047 |
| Eagle Blue 80 MD | 4941102 | 5/16 | | 2.19 | 56 | 2.1 | 9.4 | 3.3 | 14.5 | 4.3 | 19.3 | 5.5 | 24.3 | 0.037 | 0.055 |
| Eagle Orange 85 | 1032010 | 5/16 | | 2.5 | 64 | 3 | 13.5 | 4.7 | 20.8 | 6.2 | 27.7 | 7.7 | 34.1 | 0.04 | 0.059 |
| Eagle Clear 85 | 4908015 | 5/16 | | 2.5 | 64 | 3 | 13.5 | 4.7 | 20.8 | 6.2 | 27.7 | 7.7 | 34.1 | 0.04 | 0.059 |
| Eagle Clear 95 | 4907015 | 5/16 | | 3.13 | 79 | 5.7 | 25.2 | 8.4 | 37.4 | 10.8 | 48.1 | 12.9 | 57.2 | 0.041 | 0.061 |
| Eagle Clear 85 QC | 4934015 | .313 x .126† | | 2.5 | 64 | 1.3 | 5.7 | 2 | 8.9 | 2.7 | 11.9 | 3.3 | 14.7 | 0.034 | 0.05 |
| Eagle Yellow 85 QC | 4934023 | .313 x .126† | | 2.5 | 64 | 1.3 | 5.7 | 2 | 8.9 | 2.7 | 11.9 | 3.3 | 14.7 | 0.034 | 0.05 |
| Eagle Blue 80 EC | 4928006 | | 8 | 2.2 | 56 | 2.4 | 10.5 | 3.6 | 16.2 | 4.8 | 21.5 | 6.1 | 26.9 | 0.038 | 0.056 |
| Eagle Clear 80 EC | 4927006 | | 8 | 2.2 | 56 | 2.4 | 10.5 | 3.6 | 16.2 | 4.8 | 21.5 | 6.1 | 26.9 | 0.038 | 0.056 |
| Eagle Opaque 80 | L04OP808M | | 8 | 2.2 | 56 | 3.3 | 14.7 | 5.6 | 25 | 7.8 | 34.9 | 9.9 | 43.9 | 0.041 | 0.061 |
| Eagle Orange 85 | L04OG858M | | 8 | 2.52 | 64 | 3.1 | 13.7 | 4.7 | 21.1 | 6.3 | 28.1 | 7.8 | 34.7 | 0.041 | 0.06 |
| Eagle Clear 85 | L04C858 | | 8 | 2.52 | 64 | 3.1 | 13.7 | 4.7 | 21.1 | 6.3 | 28.1 | 7.8 | 34.7 | 0.041 | 0.06 |
| Eagle Blue 85 | L04BL858M | | 8 | 2.52 | 64 | 3.1 | 13.7 | 4.7 | 21.1 | 6.3 | 28.1 | 7.8 | 34.7 | 0.041 | 0.06 |
| Eagle Green 89 | L04G898MS | | 8 | 2.83 | 72 | 5.1 | 22.8 | 8.4 | 37.4 | 11.5 | 51.3 | 14.4 | 64.1 | 0.04 | 0.06 |
| Eagle Green 89 Textured | 4950308 | | 8 | 2.83 | 72 | 3.7 | 16.6 | 6.1 | 27.2 | 8.4 | 37.3 | 10.5 | 46.7 | 0.04 | 0.06 |
| Eagle Red 90 | 4940024 | | 8 | 3.15 | 80 | 16.8 | 74.9 | 24.3 | 107.9 | 30.5 | 135.8 | 35.7 | 158.9 | 0.041 | 0.061 |
| Eagle Beige 95 | L04BE958 | | 8 | 3.15 | 80 | 13.6 | 60.5 | 19.3 | 85.7 | 24.1 | 107 | 28.1 | 125.1 | 0.042 | 0.062 |
| Eagle White 40D | L04BY408M | | 8 | 3.78 | 96 | 13.3 | 59.2 | 20.5 | 91 | 26.8 | 119.3 | 32.3 | 143.8 | 0.04 | 0.059 |
| Eagle Blue 80 EC QC | 4928022 | 8 x 3.2† | | 2.2 | 56 | 1 | 4.6 | 1.6 | 7.1 | 2.2 | 9.6 | 2.7 | 11.9 | 0.032 | 0.047 |
| Eagle Clear 85 QC | L04QC858M | 8 x 3.2† | | 2.52 | 64 | 1.3 | 5.8 | 2 | 9 | 2.7 | 12.1 | 3.4 | 14.9 | 0.034 | 0.051 |
| Eagle Red 85 QC | L04QR858M | 8 x 3.2† | | 2.52 | 64 | 1.3 | 5.8 | 2 | 9 | 2.7 | 12.1 | 3.4 | 14.9 | 0.034 | 0.051 |
| Eagle Blue 85 QC | L04QB858M | 8 x 3.2† | | 2.52 | 64 | 1.3 | 5.7 | 2 | 8.9 | 2.7 | 11.9 | 3.3 | 14.6 | 0.034 | 0.051 |
| QC Connectors | L04CON85 | 25/pack | | | | | | | | | | | | | |
| REINFORCED | Part Number* | Dimensions Ø (in) (mm) | Minimum Pulley Ø (in) (mm) | Working Load @ Percent Tension | | | | | | | | Weight | | | |
| Material and Color | | | | 1% | | 2% | | 3% | | 4% | | lbs/ft | kg/m | | |
| | | | | (lbs) | (N) | (lbs) | (N) | (lbs) | (N) | (lbs) | (N) | | | | |
| Eagle Green 89 | L04G897MRS | 7 | 2.76 | 70 | 3.3 | 14.5 | 9.8 | 43.5 | 20.1 | 89.2 | 30.9 | 137.6 | 0.031 | 0.046 | |
| Eagle Green 89 Textured | 4940050 | 7 | 2.76 | 70 | 4.5 | 19.9 | 13.5 | 59.9 | 27.6 | 122.7 | 42.5 | 189.2 | 0.031 | 0.046 | |
| Eagle Orange 85 | 4940059 | 5/16 | 3.13 | 79 | 1.3 | 5.6 | 4.3 | 19.3 | 8.5 | 37.6 | 12.1 | 54 | 0.04 | 0.059 | |
| Eagle Hyfen 85 | 5218015 | 5/16 | 3.44 | 87 | 3.7 | 16.5 | 12.4 | 55.2 | 20 | 89 | 27.8 | 123.7 | 0.04 | 0.059 | |
| Eagle Orange 85 | L04OG858R | 8 | 3.15 | 80 | 1.3 | 5.7 | 4.4 | 19.6 | 8.6 | 38.2 | 12.3 | 54.8 | 0.041 | 0.06 | |
| Eagle Green 89 | L04G898MRS | 8 | 3.15 | 80 | 4.3 | 18.9 | 12.8 | 56.8 | 26.2 | 116.4 | 40.4 | 179.5 | 0.04 | 0.06 | |
| Eagle Green 89 Textured | 4940051 | 8 | 3.15 | 80 | 5.8 | 26 | 17.6 | 78.2 | 36 | 160.1 | 55.5 | 246.8 | 0.04 | 0.06 | |
| Eagle Beige 95 | L04BE958R | 8 | 3.78 | 96 | 3.8 | 16.9 | 7 | 31.1 | 10.4 | 46.3 | 13.6 | 60.5 | 0.042 | 0.062 | |

Trackstar® Round Belt Guides

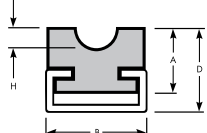

| | Part Numbers | | | | Channel Type | A | B | D | H |
|--------------------------------|--------------------|-------------------------|------------------|-----------|--------------|------|------|-----|------|
| | Galvanized Channel | Stainless Steel Channel | Aluminum Channel | UHMW Only | | | | | |
| Belt Guide w/ Mounting Channel | GB1001-3G | GB1001-3S | GB1001-3A | GB1001 | C3 | 0.59 | 0.79 | 0.8 | 0.19 |

Trackstar Guides are stocked in North America and supplied in 120" standard lengths. Subject to a minimum order quantity. Dimensions are in inches and are for reference only.

* Standard package length 100' / 30.5m

† QC dimensions are shown O.D x I.D. (O.D. is the outer diameter of the belt. I.D. is the inner diameter of the belt) Dimensions are for reference only.

9mm, 9.5mm, 3/8" Round Cross Sections

Round Link Belting



| LINK BELTING | Part Number | Cross Section | Minimum Pulley Ø (in) | Minimum Pulley Ø (mm) | Max Product Weight w/Idlers | | Max Product Weight w/UHMW | |
|----------------|-------------|---------------|-----------------------|-----------------------|-----------------------------|------|---------------------------|------|
| | 25' | | | | (lbs) | (kg) | (lbs) | (kg) |
| Tango™ Belting | 0470225 | 3/8" | 3.0 | 76 | 190 | 86 | 65 | 30 |

Round Belting

| NON-REINFORCED | Part Number* | Dimensions Ø | | Minimum Pulley Ø | | Working Load @ Percent Tension | | | | | | | | Weight | |
|-----------------------------|--------------|--------------|------------|------------------|------|--------------------------------|-------|-------|-------|--------|-------|-------|-------|--------|-------|
| | | | | | | 4% | 6% | 8% | 10% | lbs/ft | kg/m | | | | |
| Material and Color | | (in) | (mm) | (in) | (mm) | (lbs) | (N) | (lbs) | (N) | (lbs) | (N) | (lbs) | (N) | | |
| Eagle® Green 89 Textured | L04G899 | | 9 | 3.19 | 81 | 4.7 | 21 | 7.7 | 34.4 | 10.6 | 47.2 | 13.3 | 59 | 0.051 | 0.076 |
| Eagle Blue 80 MD | 4941103 | 3/8 | 9.5 | 2.63 | 67 | 3 | 13.5 | 4.7 | 20.9 | 6.3 | 27.9 | 7.8 | 34.8 | 0.054 | 0.08 |
| Eagle Opaque 80 | 4940005 | 3/8 | 9.5 | 2.63 | 67 | 4.7 | 20.8 | 8 | 35.4 | 11.1 | 49.4 | 14 | 62.3 | 0.058 | 0.087 |
| Eagle Orange 85 | 1032012 | 3/8 | 9.5 | 3 | 76 | 4.4 | 19.4 | 6.7 | 29.9 | 9 | 39.9 | 11.1 | 49.2 | 0.057 | 0.086 |
| Eagle Orange 89 SureConnect | 4934145 | 3/8 | 9.5 | 3 | 76 | 4.4 | 19.4 | 6.7 | 29.9 | 9 | 39.9 | 11.1 | 49.2 | 0.057 | 0.086 |
| Eagle Clear 85 | 4908018 | 3/8 | 9.5 | 3 | 76 | 4.4 | 19.4 | 6.7 | 29.9 | 9 | 39.9 | 11.1 | 49.2 | 0.057 | 0.086 |
| Eagle Red 90 | 4940025 | 3/8 | 9.5 | 3.75 | 95 | 23.9 | 106.1 | 34.4 | 152.9 | 43.3 | 192.4 | 50.6 | 225.1 | 0.058 | 0.086 |
| Eagle Clear 95 | 4907018 | 3/8 | 9.5 | 3.75 | 95 | 8.2 | 36.3 | 12.1 | 53.9 | 15.6 | 69.3 | 18.5 | 82.4 | 0.059 | 0.088 |
| Eagle Clear 85 QC | 4934018 | .375 x .152† | | 3 | 76 | 1.8 | 8.2 | 2.9 | 12.7 | 3.8 | 17.1 | 4.7 | 21 | 0.048 | 0.071 |
| Eagle Yellow 85 QC | 4934025 | .375 x .152† | | 3 | 76 | 1.8 | 8.2 | 2.9 | 12.7 | 3.8 | 17.1 | 4.7 | 21 | 0.048 | 0.071 |
| Eagle Blue 80 EC | 4928007 | 3/8 | 9.5 | 2.62 | 67 | 3.4 | 15 | 5.2 | 23.2 | 7 | 31 | 8.7 | 38.7 | 0.053 | 0.079 |
| Eagle Blue 85 | L04BL859.5M | 3/8 | 9.5 | 3 | 76 | 4.4 | 19.4 | 6.7 | 29.9 | 9 | 39.9 | 11.1 | 49.2 | 0.057 | 0.085 |
| Eagle Green 89 | L04G899.5MS | 3/8 | 9.5 | 3.39 | 86 | 7.2 | 32.1 | 11.8 | 52.7 | 16.3 | 72.4 | 20.3 | 90.4 | 0.057 | 0.084 |
| Eagle Blue 80 EC QC | 4928023 | | 9.5 x 3.8† | 2.64 | 67 | 1.5 | 6.4 | 2.3 | 10.1 | 3 | 13.5 | 3.8 | 16.8 | 0.045 | 0.067 |
| QC Connectors | L04CON10S | 20/pack | | | | | | | | | | | | | |
| SureConnect Connectors | 4935031 | 5/pack | | | | | | | | | | | | | |
| REINFORCED | Part Number* | Dimensions Ø | | Minimum Pulley Ø | | Working Load @ Percent Tension | | | | | | | | Weight | |
| Material and Color | | | | | | 1% | 2% | 3% | 4% | lbs/ft | kg/m | | | | |
| | | (in) | (mm) | (in) | (mm) | (lbs) | (N) | (lbs) | (N) | (lbs) | (N) | (lbs) | (N) | | |
| Eagle Orange 85 | 4940060 | 3/8 | 9.5 | 3.75 | 95 | 1.8 | 8 | 6.2 | 27.8 | 12.2 | 54.2 | 17.5 | 77.8 | 0.057 | 0.086 |
| Eagle Hyfen 85 | 5218018 | 3/8 | 9.5 | 4.13 | 105 | 7.3 | 32.5 | 26.2 | 116.5 | 43.5 | 193.5 | 57.4 | 255.3 | 0.057 | 0.086 |

Can Cable

| REINFORCED | Part Number‡ | Dimensions Ø | | Minimum Pulley Ø | | Working Load @ Percent Tension | | | | | | | | Weight | |
|---------------------------|--------------|--------------|------|------------------|------|--------------------------------|-------|-------|-------|--------|--------|-------|-------|--------|-------|
| Material and Color | | | | | | 1% | 2% | 3% | 4% | lbs/ft | kg/m | | | | |
| | | (in) | (mm) | (in) | (mm) | (lbs) | (N) | (lbs) | (N) | (lbs) | (N) | (lbs) | (N) | | |
| Blue 55D Can Cable | 4816019 | 3/8 | 9.5 | 12 | 305 | 18.1 | 80.4 | 42.9 | 190.6 | 79.4 | 353.1 | 118.4 | 526.5 | 0.057 | 0.086 |
| Natural 55D Can Cable | 4816018 | 3/8 | 9.5 | 12 | 305 | 18.1 | 80.4 | 42.9 | 190.6 | 79.4 | 353.1 | 118.4 | 526.5 | 0.057 | 0.086 |
| Natural 63D Can Cable | 4899006 | 3/8 | 9.5 | 12 | 305 | 18.1 | 80.4 | 42.9 | 190.6 | 79.4 | 353.1 | 118.4 | 526.5 | 0.058 | 0.087 |
| Red 50D LCF Can Cable | 4816020 | 3/8 | 9.5 | 10 | 254 | 23.8 | 105.9 | 57.8 | 257.2 | 104.3 | 463.8 | 152.3 | 677.2 | 0.058 | 0.087 |
| Green 63D Can Cable | 4817018 | 3/8 | 9.5 | 12 | 305 | 18.1 | 80.4 | 42.9 | 190.6 | 79.4 | 353.1 | 118.4 | 526.5 | 0.058 | 0.087 |
| Blue 55D Aramid Can Cable | 4899012 | 3/8 | 9.5 | 12 | 305 | 41.7 | 185.5 | 149.1 | 663.2 | 281.1 | 1250.4 | — | — | 0.057 | 0.086 |

Trackstar® Round Belt Guides

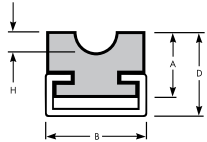

| | Part Numbers | | | Channel Type | A | B | D | H |
|--------------------------------|--------------------|-------------------------|-----------|--------------|------|-----|------|------|
| | Galvanized Channel | Stainless Steel Channel | UHMW Only | | | | | |
| Belt Guide w/ Mounting Channel | GB1002-5G | GB1002-5S | GB1002 | CS | 0.59 | 1.1 | 0.84 | 0.22 |

Trackstar Guides are stocked in North America and supplied in 120" standard lengths. Subject to a minimum order quantity. Dimensions are in inches and are for reference only.

* Standard package length 100' / 30.5m

† QC dimensions are shown O.D x I.D. (O.D. is the outer diameter of the belt. I.D. is the inner diameter of the belt.) Dimensions are for reference only.

‡ Standard Can Cable package length 500' reel

10mm, 12mm, 12.7mm, 1/2" Round Cross Sections

Round Link Belting



Round

| LINK BELTING | Part Number | | Cross Section | Minimum Pulley Ø | | Max Product Weight w/Idlers | | Max Product Weight w/UHMW | |
|----------------|-------------|---------|---------------|------------------|------|-----------------------------|------|---------------------------|------|
| | 25' | 10m | | (in) | (mm) | (lbs) | (kg) | (lbs) | (kg) |
| Tango™ Belting | | 0470233 | 10mm | 3.0 | 76 | 190 | 86 | 65 | 30 |
| Tango Belting | 0470325 | | 1/2" | 3.0 | 76 | 255 | 116 | 85 | 39 |

Round Belting

| NON-REINFORCED | Part Number* | Dimensions Ø (in) (mm) | Minimum Pulley Ø (in) (mm) | Working Load @ Percent Tension | | | | | | | | Weight | | | |
|------------------------------|--------------|------------------------------------|----------------------------|--------------------------------|-------|-------|-------|-------|-------|-------|-------|--------|-------|-------|-------|
| | | | | 4% | | 6% | | 8% | | 10% | | lbs/ft | kg/m | | |
| Material and Color | | | | (lbs) | (N) | (lbs) | (N) | (lbs) | (N) | (lbs) | (N) | | | | |
| Eagle® Blue 80 EC | 4928008 | 10 | 2.76 70 | 3.7 | 16.4 | 5.8 | 25.6 | 7.7 | 34.1 | 9.6 | 42.6 | 0.059 | 0.088 | | |
| Eagle Clear 80 EC | 4927008 | 10 | 2.76 70 | 3.7 | 16.4 | 5.8 | 25.6 | 7.7 | 34.1 | 9.6 | 42.6 | 0.059 | 0.088 | | |
| Eagle Opaque 80 | L04OP8010M | 10 | 2.76 70 | 5.1 | 22.9 | 8.8 | 39 | 12.2 | 54.5 | 15.4 | 68.6 | 0.064 | 0.096 | | |
| Eagle Orange 85 | L04OG8510M | 10 | 3.15 80 | 4.8 | 21.4 | 7.4 | 33 | 9.9 | 44 | 12.2 | 54.2 | 0.063 | 0.094 | | |
| Eagle Clear 85 | L04C8510M | 10 | 3.15 80 | 4.8 | 21.4 | 7.4 | 33 | 9.9 | 44 | 12.2 | 54.2 | 0.063 | 0.094 | | |
| Eagle Blue 85 | L04BL8510M | 10 | 3.15 80 | 4.8 | 21.4 | 7.4 | 33 | 9.9 | 44 | 12.2 | 54.2 | 0.063 | 0.094 | | |
| Eagle Green 89 | L04G8910MS | 10 | 3.54 90 | 8 | 35.4 | 13.1 | 58.2 | 18 | 79.9 | 22.4 | 99.8 | 0.063 | 0.093 | | |
| Eagle Green 89 Textured | 4905310 | 10 | 3.54 90 | 5.8 | 25.8 | 9.5 | 42.3 | 13.1 | 58.1 | 16.3 | 72.5 | 0.063 | 0.093 | | |
| Eagle Green 89 T SureConnect | 4934141 | 10 | 3.54 90 | 5.8 | 25.8 | 9.5 | 42.3 | 13.1 | 58.1 | 16.3 | 72.5 | 0.063 | 0.093 | | |
| Eagle Red 90 | L04R9010M | 10 | 3.94 100 | 26.3 | 116.9 | 37.9 | 168.4 | 47.6 | 211.9 | 55.7 | 248 | 0.064 | 0.095 | | |
| Eagle Beige 95 | L04BE9510M | 10 | 3.94 100 | 21.2 | 94.5 | 30.1 | 133.8 | 37.6 | 167.2 | 43.9 | 195.5 | 0.065 | 0.097 | | |
| Eagle White 40D | L04BY4010M | 10 | 4.72 120 | 20.8 | 92.5 | 32 | 142.2 | 41.9 | 186.5 | 50.5 | 224.6 | 0.062 | 0.092 | | |
| Eagle Blue 55D | L04BY5510M | 10 | 5.12 130 | 39.3 | 174.6 | 60.4 | 268.7 | 78.5 | 349.2 | 93 | 413.8 | 0.063 | 0.094 | | |
| Eagle Red 85 QC | L04QR8510M | 10 × 3.8† | 3.15 80 | 2.1 | 9.3 | 3.2 | 14.4 | 4.3 | 19.3 | 5.3 | 23.8 | 0.054 | 0.081 | | |
| Eagle Blue 85 QC | L04QB8510M | 10 × 3.8† | 3.15 80 | 2.1 | 9.3 | 3.2 | 14.4 | 4.3 | 19.3 | 5.3 | 23.8 | 0.054 | 0.081 | | |
| Eagle Orange 85 | L04OG8512M | 12 | 3.78 96 | 6.9 | 30.8 | 10.7 | 47.5 | 14.2 | 63.3 | 17.5 | 78 | 0.091 | 0.136 | | |
| Eagle Clear 85 | L04C8512M | 12 | 3.78 96 | 6.9 | 30.8 | 10.7 | 47.5 | 14.2 | 63.3 | 17.5 | 78 | 0.091 | 0.136 | | |
| Eagle Green 89 | L04G8912MS | 12 | 4.25 108 | 11.5 | 51.2 | 18.9 | 84.1 | 26 | 115.5 | 32.4 | 144.3 | 0.09 | 0.135 | | |
| Eagle Green 89 Textured | 4905312 | 12 | 4.25 108 | 8.4 | 37.3 | 13.8 | 61.2 | 18.9 | 84.1 | 23.6 | 105.1 | 0.091 | 0.135 | | |
| Eagle Green 89 T SureConnect | 4934142 | 12 | 4.25 108 | 8.4 | 37.3 | 13.8 | 61.2 | 18.9 | 84.1 | 23.6 | 105.1 | 0.091 | 0.135 | | |
| Eagle Red 90 | L04R9012M | 12 | 4.72 120 | 37.8 | 168.4 | 54.5 | 242.5 | 68.6 | 305.2 | 80.3 | 357.2 | 0.092 | 0.137 | | |
| Eagle Red 85 QC | L04QR8512M | 12 × 5.2† | 3.78 96 | 2.8 | 12.6 | 4.4 | 19.7 | 5.9 | 26.3 | 7.3 | 32.5 | 0.074 | 0.11 | | |
| Eagle Blue 85 QC | L04QB8512 | 12 × 5.2† | 3.78 96 | 2.8 | 12.6 | 4.4 | 19.7 | 5.9 | 26.3 | 7.3 | 32.5 | 0.074 | 0.11 | | |
| Eagle Blue 80 MD | 4941105 | 1/2 | 12.7 | 3.5 | 89 | 5.4 | 23.9 | 8.4 | 37.3 | 11.2 | 49.7 | 13.8 | 61.6 | 0.095 | 0.142 |
| Eagle Orange 85 | 1032016 | 1/2 | 12.7 | 4 | 102 | 7.8 | 34.5 | 12 | 53.2 | 16 | 71 | 19.6 | 87.4 | 0.102 | 0.152 |
| Eagle Orange 89 SureConnect | 4934146 | 1/2 | 12.7 | 4 | 102 | 7.8 | 34.5 | 12 | 53.2 | 16 | 71 | 19.6 | 87.4 | 0.102 | 0.152 |
| Eagle Clear 85 | 4908024 | 1/2 | 12.7 | 4 | 102 | 7.8 | 34.5 | 12 | 53.2 | 16 | 71 | 19.6 | 87.4 | 0.102 | 0.152 |
| Eagle Red 90 | 4940026 | 1/2 | 12.7 | 5 | 127 | 42.4 | 188.6 | 61.1 | 271.7 | 76.9 | 342 | 90 | 400.2 | 0.103 | 0.153 |
| Eagle Clear 95 | 4907024 | 1/2 | 12.7 | 5 | 127 | 14.5 | 64.6 | 21.6 | 95.9 | 27.7 | 123.1 | 32.9 | 146.4 | 0.105 | 0.156 |
| Eagle Clear 85 QC | 4934024 | .500 × .205† | 4 | 102 | 3.3 | 14.5 | 5.1 | 22.5 | 6.8 | 30.2 | 8.4 | 37.2 | 0.085 | 0.126 | |
| Eagle Yellow 85 QC | 4934026 | .500 × .205† | 4 | 102 | 3.3 | 14.5 | 5.1 | 22.5 | 6.8 | 30.2 | 8.4 | 37.2 | 0.085 | 0.126 | |
| Eagle Red 85 | L04R8512.7 | 1/2 | 12.7 | 4 | 102 | 7.8 | 34.5 | 12 | 53.2 | 16 | 71 | 19.6 | 87.4 | 0.102 | 0.152 |
| Eagle Blue 85 | L04BL8512.7 | 1/2 | 12.7 | 4 | 102 | 7.8 | 34.5 | 12 | 53.2 | 15.9 | 70.9 | 19.6 | 87.4 | 0.102 | 0.152 |
| QC Connectors | L04CON10S | 20/pack (Use for 3/8" and 10mm) | | | | | | | | | | | | | |
| QC Connectors | L04CON13S | 20/pack (Use for 1/2" and 12-13mm) | | | | | | | | | | | | | |
| SureConnect Connectors | 4935031 | 5/pack (Use for 10mm) | | | | | | | | | | | | | |
| SureConnect Connectors | 4935032 | 5/pack (Use for 1/2" and 12mm) | | | | | | | | | | | | | |
| REINFORCED | Part Number* | Dimensions Ø (in) (mm) | Minimum Pulley Ø (in) (mm) | Working Load @ Percent Tension | | | | | | | | Weight | | | |
| Material and Color | | | | 1% | | 2% | | 3% | | 4% | | lbs/ft | kg/m | | |
| | | | | (lbs) | (N) | (lbs) | (N) | (lbs) | (N) | (lbs) | (N) | | | | |
| Eagle Orange 85 | L04OG8510MR | 10 | 3.94 100 | 2 | 8.8 | 6.9 | 30.6 | 13.4 | 59.7 | 19.3 | 85.7 | 0.063 | 0.094 | | |
| Eagle Green 89 | L04G8910MRS | 10 | 3.94 100 | 6.6 | 29.5 | 20 | 88.8 | 40.9 | 181.9 | 63.1 | 280.5 | 0.063 | 0.093 | | |
| Eagle Green 89 Textured | 4940052 | 10 | 3.94 100 | 9.1 | 40.6 | 27.5 | 122.1 | 56.2 | 250.1 | 86.7 | 385.6 | 0.063 | 0.093 | | |
| Eagle Beige 95 | L04BE9510R | 10 | 4.72 120 | 6 | 26.7 | 11 | 48.9 | 16.2 | 72.1 | 21.2 | 94.3 | 0.065 | 0.097 | | |
| Eagle Orange 85 | L04OG8512R | 12 | 4.72 120 | 2.9 | 12.7 | 9.9 | 44.1 | 19.3 | 85.9 | 27.7 | 123.4 | 0.091 | 0.136 | | |
| Eagle Green 89 | L04G8912MRS | 12 | 4.72 120 | 9.6 | 42.6 | 28.8 | 127.9 | 58.9 | 262 | 90.8 | 404 | 0.09 | 0.135 | | |
| Eagle Green 89 Textured | 4940053 | 12 | 4.72 120 | 13.2 | 58.5 | 39.5 | 175.9 | 81 | 360.2 | 124.9 | 555.4 | 0.09 | 0.135 | | |
| Eagle Orange 85 | 4940061 | 1/2 | 12.7 | 5 | 127 | 3.2 | 14.2 | 11.1 | 49.4 | 21.6 | 96.3 | 31.1 | 138.3 | 0.102 | 0.152 |
| Eagle Hyfen 85 | 5218024 | 1/2 | 12.7 | 5.5 | 140 | 7.3 | 32.5 | 26.2 | 116.5 | 43.5 | 193.5 | 57.4 | 255.3 | 0.102 | 0.152 |

Trackstar® Round Belt Guides

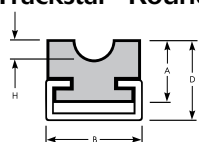

| | Part Numbers | | | Channel Type | A | B | D | H |
|--------------------------------|--------------------|-------------------------|-----------|--------------|------|-----|------|------|
| | Galvanized Channel | Stainless Steel Channel | UHMW Only | | | | | |
| Belt Guide w/ Mounting Channel | GB1003-5G | GB1003-5S | GB1003 | C5 | 0.59 | 1.1 | 0.84 | 0.28 |

Trackstar Guides are stocked in North America and supplied in 120" standard lengths. Subject to a minimum order quantity. Dimensions are in inches and are for reference only.

13mm, 14mm 9/16" Round Cross Sections



Round Link Belting

| LINK BELTING | Part Number | | Cross Section | Minimum Pulley Ø | | Max Product Weight w/Idlers | | Max Product Weight w/UHMW | |
|----------------|-------------|---------|---------------|------------------|------|-----------------------------|------|---------------------------|------|
| | 25' | 10m | | (in) | (mm) | (lbs) | (kg) | (lbs) | (kg) |
| Tango™ Belting | | 0470333 | 13mm | 3.0 | 76 | 255 | 116 | 85 | 39 |
| Tango Belting | | 0470433 | 14mm | 5.5 | 140 | 450 | 204 | 155 | 70 |
| Tango Belting | 0470425 | | 9/16" | 5.5 | 140 | 450 | 204 | 155 | 70 |

Round Belting

| NON-REINFORCED | | Part Number* | Dimensions Ø | | Minimum Pulley Ø | | Working Load @ Percent Tension | | | | | | Weight | | |
|-----------------------------|------------|--------------|-----------------------|------|------------------|------|--------------------------------|------|-------|----------|--------|----------|--------|----------|--------|
| Material and Color | (in) | | | | | | (mm) | (in) | (mm) | 4% (lbs) | 4% (N) | 6% (lbs) | 6% (N) | 8% (lbs) | 8% (N) |
| Eagle® Clear 85 QC | L04QC8513 | | 13 x 5.2 [†] | 4.09 | 104 | 3.5 | 15.3 | 5.4 | 23.8 | 7.2 | 31.9 | 8.9 | 39.4 | 0.09 | 0.134 |
| Eagle Red 85 QC | L04QR8513M | | 13 x 5.2 [†] | 4.09 | 104 | 3.5 | 15.3 | 5.4 | 23.8 | 7.2 | 31.9 | 8.9 | 39.4 | 0.09 | 0.134 |
| Eagle Blue 80 MD | 4941106 | 9/16 | | 3.94 | 100 | 6.9 | 30.6 | 10.6 | 47.1 | 14.2 | 63 | 17.6 | 78.2 | 0.121 | 0.18 |
| Eagle Orange 85 | 1032018 | 9/16 | | 4.5 | 114 | 9.8 | 43.7 | 15.1 | 67.3 | 20.2 | 89.8 | 24.9 | 110.6 | 0.129 | 0.192 |
| Eagle Orange 89 SureConnect | 4934147 | 9/16 | | 4.5 | 114 | 9.8 | 43.7 | 15.1 | 67.3 | 20.2 | 89.8 | 24.9 | 110.6 | 0.129 | 0.192 |
| Eagle Clear 85 | 4908027 | 9/16 | | 4.5 | 114 | 9.8 | 43.7 | 15.1 | 67.3 | 20.2 | 89.8 | 24.9 | 110.6 | 0.129 | 0.192 |
| Eagle Red 90 | 4940036 | 9/16 | | 5.63 | 143 | 53.7 | 238.6 | 77.3 | 343.8 | 97.3 | 432.7 | 113.8 | 506.3 | 0.13 | 0.194 |
| Eagle Clear 95 | 4907027 | 9/16 | | 5.63 | 143 | 18.4 | 81.7 | 27.3 | 121.3 | 35 | 155.8 | 41.7 | 185.3 | 0.133 | 0.197 |
| QC Connectors | L04CON135 | 20/pack | | | | | | | | | | | | | |
| SureConnect Connectors | 4935033 | 5/pack | | | | | | | | | | | | | |

| REINFORCED | | Part Number* | Dimensions Ø | | Minimum Pulley Ø | | Working Load @ Percent Tension | | | | Weight | | | | |
|--------------------|---------|--------------|--------------|------|------------------|------|--------------------------------|------|-------|----------|----------|----------|----------|--------|--------|
| Material and Color | (in) | | | | | | (mm) | (in) | (mm) | 1% (lbs) | 2% (lbs) | 3% (lbs) | 4% (lbs) | 1% (N) | 2% (N) |
| Eagle Orange 85 | 4940062 | 9/16 | | 5.63 | 143 | 4.1 | 18 | 14 | 62.5 | 27.4 | 121.8 | 39.3 | 174.9 | 0.129 | 0.192 |
| Eagle Hyfen 85 | 5218027 | 9/16 | | 6.19 | 157 | 16.7 | 74.3 | 36.6 | 162.8 | 58 | 258 | 75.8 | 337.2 | 0.129 | 0.192 |

Trackstar® Round Belt Guides

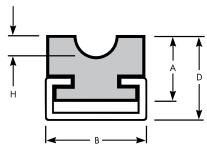

| | Part Numbers | | | Channel Type | A | B | D | H |
|--------------------------------|--------------------|-------------------------|-----------|--------------|------|-----|------|------|
| | Galvanized Channel | Stainless Steel Channel | UHMW Only | | | | | |
| Belt Guide w/ Mounting Channel | GB1004-5G | GB1004-5S | GB1004 | C5 | 0.59 | 1.1 | 0.84 | 0.32 |

Trackstar Guides are stocked in North America and supplied in 120" standard lengths. Subject to a minimum order quantity. Dimensions are in inches and are for reference only.

* Standard package length 100' / 30.5m

† QC dimensions are shown O.D x I.D. (O.D. is the outer diameter of the belt. I.D. is the inner diameter of the belt). Dimensions are for reference only.

15mm, 16mm, 5/8" Round Cross Sections



Round Belting

| NON-REINFORCED | | | | Working Load @ Percent Tension | | | | | | | | | | Weight | |
|------------------------------|--------------|--------------|-----------|--------------------------------|------|-------|-------|-------|-------|-------|-------|-------|-------|--------|-------|
| Material and Color | Part Number* | Dimensions Ø | | Minimum Pulley Ø | | 4% | | 6% | | 8% | | 10% | | lbs/ft | kg/m |
| | | (in) | (mm) | (in) | (mm) | (lbs) | (N) | (lbs) | (N) | (lbs) | (N) | (lbs) | (N) | | |
| Eagle® Opaque 80 | L04OP8015M | | 15 | 4.13 | 105 | 11.6 | 51.6 | 19.7 | 87.7 | 27.6 | 122.6 | 34.7 | 154.4 | 0.145 | 0.216 |
| Eagle Blue 85 | L04BL8515 | | 15 | 4.72 | 120 | 10.8 | 48.1 | 16.7 | 74.2 | 22.2 | 99 | 27.4 | 121.9 | 0.142 | 0.212 |
| Eagle Green 89 | L04G8915MS | | 15 | 5.31 | 135 | 18 | 80 | 29.5 | 131.4 | 40.6 | 180.5 | 50.7 | 225.5 | 0.141 | 0.21 |
| Eagle Green 89 Textured | 4905315 | | 15 | 5.31 | 135 | 13.1 | 58.1 | 21.5 | 95.4 | 29.5 | 131.1 | 36.8 | 163.8 | 0.141 | 0.21 |
| Eagle Green 89 T SureConnect | 4934143 | | 15 | 5.31 | 135 | 13.1 | 58.1 | 21.5 | 95.4 | 29.5 | 131.1 | 36.8 | 163.8 | 0.141 | 0.21 |
| Eagle Red 90 | 4999315 | | 15 | 5.91 | 150 | 59.1 | 262.9 | 85.2 | 378.8 | 107.2 | 476.8 | 125.4 | 557.9 | 0.144 | 0.214 |
| Eagle Beige 95 | L04BE9515M | | 15 | 5.91 | 150 | 47.8 | 212.5 | 67.7 | 301.2 | 84.6 | 376.2 | 98.9 | 440 | 0.146 | 0.217 |
| Eagle White 40D | L04BY4015 | | 15 | 7.09 | 180 | 46.8 | 208.1 | 71.9 | 319.9 | 94.3 | 419.6 | 113.6 | 505.4 | 0.139 | 0.207 |
| Eagle Blue 55D | L04BY5515 | | 15 | 7.68 | 195 | 88.3 | 392.9 | 135.9 | 604.6 | 176.7 | 785.8 | 209.3 | 931 | 0.142 | 0.212 |
| Eagle Blue 80 MD | 4941107 | 5/8 | | 4.38 | 111 | 8.4 | 37.5 | 13.1 | 58.2 | 17.4 | 77.6 | 21.7 | 96.4 | 0.149 | 0.222 |
| Eagle Orange 85 | 1032020 | 5/8 | | 5 | 127 | 12.1 | 53.9 | 18.7 | 83.1 | 24.9 | 110.8 | 30.7 | 136.5 | 0.16 | 0.238 |
| Eagle Clear 85 | 4908030 | 5/8 | | 5 | 127 | 12.1 | 53.9 | 18.7 | 83.1 | 24.9 | 110.8 | 30.7 | 136.5 | 0.16 | 0.238 |
| Eagle Clear 95 | 4907030 | 5/8 | | 6.25 | 159 | 22.7 | 100.9 | 33.7 | 149.8 | 43.2 | 192.3 | 51.4 | 228.7 | 0.164 | 0.243 |
| Eagle Clear 85 QC | 4934030 | .625 x .273† | | 5 | 127 | 5 | 22.1 | 7.7 | 34.2 | 10.3 | 45.9 | 12.7 | 56.6 | 0.129 | 0.192 |
| Eagle Yellow 85 QC | 4934020 | .625 x .273† | | 5 | 127 | 5 | 22.1 | 7.7 | 34.2 | 10.3 | 45.9 | 12.7 | 56.6 | 0.129 | 0.192 |
| Eagle Clear 85 QC | L04QC8516M | | 16 x 6.8† | 5.04 | 128 | 5.1 | 22.7 | 7.9 | 35.2 | 10.6 | 47.2 | 13.1 | 58.2 | 0.133 | 0.198 |
| Eagle Red 85 QC | L04QR8516M | | 16 x 6.8† | 5.04 | 128 | 5.1 | 22.7 | 7.9 | 35.2 | 10.6 | 47.2 | 13.1 | 58.2 | 0.133 | 0.198 |
| QC Connectors | 4935030 | 15/pack | | | | | | | | | | | | | |
| SureConnect Connectors | 4935033 | 5/pack | | | | | | | | | | | | | |
| REINFORCED | | | | Working Load @ Percent Tension | | | | | | | | | | Weight | |
| Material and Color | Part Number* | Dimensions Ø | | Minimum Pulley Ø | | 1% | | 2% | | 3% | | 4% | | lbs/ft | kg/m |
| | | (in) | (mm) | (in) | (mm) | (lbs) | (N) | (lbs) | (N) | (lbs) | (N) | (lbs) | (N) | | |
| Eagle Orange 85 | L04OG8515MR | | 15 | 5.91 | 150 | 4.5 | 19.9 | 15.5 | 68.9 | 30.2 | 134.3 | 43.3 | 192.8 | 0.142 | 0.212 |
| Eagle Green 89 | L04G8915MRS | | 15 | 5.91 | 150 | 15 | 66.5 | 44.9 | 199.9 | 92 | 409.3 | 141.9 | 631.2 | 0.141 | 0.21 |
| Eagle Green 89 Textured | 4940054 | | 15 | 5.91 | 150 | 20.6 | 91.5 | 61.8 | 274.8 | 126.5 | 562.8 | 195.1 | 867.9 | 0.141 | 0.21 |
| Eagle Beige 95 | L04BE9515R | | 15 | 7.09 | 180 | 13.5 | 60.1 | 24.7 | 109.9 | 36.5 | 162.4 | 47.8 | 212.6 | 0.146 | 0.217 |
| Eagle Hyfen 85 | 5218030 | 5/8 | | 6.88 | 175 | 16.7 | 74.3 | 36.6 | 162.8 | 58 | 258 | 75.8 | 337.2 | 0.16 | 0.238 |

Trackstar® Round Belt Guides

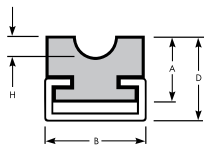

| | Part Numbers | | | Channel Type | A | B | D | H |
|--------------------------------|--------------------|-------------------------|-----------|--------------|------|-----|------|------|
| | Galvanized Channel | Stainless Steel Channel | UHMW Only | | | | | |
| Belt Guide w/ Mounting Channel | GB1005-5G | GB1005-5S | GB1005 | C5 | 0.71 | 1.1 | 0.94 | 0.35 |

Trackstar Guides are stocked in North America and supplied in 120" standard lengths. Subject to a minimum order quantity. Dimensions are in inches and are for reference only.

* Standard package length 100' / 30.5m

† QC dimensions are shown O.D x I.D. (O.D. is the outer diameter of the belt. I.D. is the inner diameter of the belt) Dimensions are for reference only.

18mm, 19mm, 20mm, 3/4" Round Cross Sections

Round Link Belting



Round

| LINK BELTING | Part Number | | Cross Section | Minimum Pulley Ø | | Max Product Weight w/Idlers | | Max Product Weight w/UHMW | |
|----------------|-------------|-----|---------------|------------------|------|-----------------------------|------|---------------------------|------|
| | 25' | 10m | | (in) | (mm) | (lbs) | (kg) | (lbs) | (kg) |
| Tango™ Belting | 0470533 | | 19mm | 8.5 | 216 | 360 | 163 | 120 | 54 |
| Tango Belting | 0470525 | | 3/4" | 8.5 | 216 | 360 | 163 | 120 | 54 |

Round Belting

| NON-REINFORCED | | Part Number* | Dimensions Ø | | Minimum Pulley Ø | | Working Load @ Percent Tension | | | | | | | | Weight | |
|------------------------------|------------|--------------------------------|--------------|------|------------------|----------|--------------------------------|----------|--------|----------|--------|-----------|---------|--------|--------|--|
| Material and Color | (in) | | (mm) | (in) | (mm) | 4% (lbs) | 4% (N) | 6% (lbs) | 6% (N) | 8% (lbs) | 8% (N) | 10% (lbs) | 10% (N) | lbs/ft | kg/m | |
| Eagle® Green 89 | L04G8918MS | 18 | 6.38 | 162 | 25.9 | 115.2 | 42.5 | 189.2 | 58.4 | 259.9 | 73 | 324.6 | 0.203 | 0.303 | | |
| Eagle Green 89 Textured | 4940091 | 18 | 6.38 | 162 | 18.8 | 83.7 | 30.9 | 137.5 | 42.4 | 188.8 | 53 | 235.9 | 0.203 | 0.303 | | |
| Eagle Green 89 T SureConnect | 4934144 | 18 | 6.38 | 162 | 18.8 | 83.7 | 30.9 | 137.5 | 42.4 | 188.8 | 53 | 235.9 | 0.203 | 0.303 | | |
| Eagle White 40D | L04BY4018 | 18 | 8.5 | 216 | 67.4 | 299.7 | 103.6 | 460.7 | 135.8 | 604.2 | 163.6 | 727.8 | 0.2 | 0.298 | | |
| Eagle Blue 55D | L04BY5518 | 18 | 9.21 | 234 | 127.2 | 565.8 | 195.7 | 870.6 | 254.4 | 1131.6 | 301.4 | 1340.7 | 0.205 | 0.305 | | |
| Eagle Orange 85 | 1032024 | 3/4 | 6 | 152 | 17.5 | 77.7 | 26.9 | 119.6 | 35.9 | 159.6 | 44.2 | 196.6 | 0.23 | 0.342 | | |
| Eagle Orange 89 SureConnect | 4934148 | 3/4 | 6 | 152 | 17.5 | 77.7 | 26.9 | 119.6 | 35.9 | 159.6 | 44.2 | 196.6 | 0.23 | 0.342 | | |
| Eagle Clear 85 | 4908033 | 3/4 | 6 | 152 | 17.5 | 77.7 | 26.9 | 119.6 | 35.9 | 159.6 | 44.2 | 196.6 | 0.23 | 0.342 | | |
| Eagle Clear 95 | 4907033 | 3/4 | 7.5 | 191 | 32.7 | 145.3 | 48.5 | 215.7 | 62.3 | 277 | 74 | 329.4 | 0.236 | 0.351 | | |
| SureConnect Connectors | 4935034 | 5/pack (Use for 18mm and 3/4") | | | | | | | | | | | | | | |

| REINFORCED | | Part Number* | Dimensions Ø | | Minimum Pulley Ø | | Working Load @ Percent Tension | | | | | | | | Weight | |
|-------------------------|---------|--------------|--------------|------|------------------|----------|--------------------------------|----------|--------|----------|--------|----------|--------|--------|--------|--|
| Material and Color | (in) | | (mm) | (in) | (mm) | 1% (lbs) | 1% (N) | 2% (lbs) | 2% (N) | 3% (lbs) | 3% (N) | 4% (lbs) | 4% (N) | lbs/ft | kg/m | |
| Eagle Green 89 Textured | 4940055 | 18 | 7.09 | 180 | 29.6 | 131.7 | 89 | 395.7 | 182.2 | 810.5 | 280.9 | 1249.7 | 0.203 | 0.303 | | |
| Eagle Orange 85 | 4940064 | 3/4 | 7.5 | 191 | 7.2 | 32.1 | 25 | 111.1 | 48.7 | 216.6 | 69.9 | 311 | 0.23 | 0.342 | | |
| Eagle Hyfen 85 | 5218033 | 3/4 | 8.25 | 210 | 16.7 | 74.3 | 36.6 | 162.8 | 58 | 258 | 75.8 | 337.2 | 0.23 | 0.342 | | |

Trackstar® Round Belt Guides

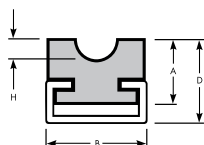

| | Part Numbers | | | Channel Type | A | B | D | H |
|--------------------------------|--------------------|-------------------------|-----------|--------------|------|-----|------|------|
| | Galvanized Channel | Stainless Steel Channel | UHMW Only | | | | | |
| Belt Guide w/ Mounting Channel | GB1007-5G | GB1007-5S | GB1007 | C5 | 1.02 | 1.1 | 1.26 | 0.41 |

Trackstar Guides are stocked in North America and supplied in 120" standard lengths. Subject to a minimum order quantity. Dimensions are in inches and are for reference only.

Round Belting – 20mm

| NON-REINFORCED | | Part Number* | Dimensions Ø | | Minimum Pulley Ø | | Working Load @ Percent Tension | | | | | | | | Weight | |
|-------------------------|------------|--------------|--------------|------|------------------|----------|--------------------------------|----------|--------|----------|--------|-----------|---------|--------|--------|--|
| Material and Color | (in) | | (mm) | (in) | (mm) | 4% (lbs) | 4% (N) | 6% (lbs) | 6% (N) | 8% (lbs) | 8% (N) | 10% (lbs) | 10% (N) | lbs/ft | kg/m | |
| Eagle Green 89 | L04G8920MS | 20 | 7.09 | 180 | 32 | 142.3 | 52.5 | 233.5 | 72.1 | 320.8 | 90.1 | 400.8 | 0.251 | 0.374 | | |
| Eagle Green 89 Textured | 4940092 | 20 | 7.09 | 180 | 23.2 | 103.4 | 38.1 | 169.7 | 52.4 | 233.1 | 65.5 | 291.2 | 0.251 | 0.374 | | |
| Eagle White 40D | L04BY4020 | 20 | 9.45 | 240 | 83.2 | 370 | 127.9 | 568.7 | 167.7 | 745.9 | 202 | 898.6 | 0.247 | 0.368 | | |

* Standard package length 100' / 30.5m

† w (width) is the widest part of the belt. h (height) is the tallest part of the belt, including the belting top surface. Dimensions are for reference only.

6x4, 8x5, 10x4mm Cross Section

V Belting

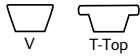

| NON-REINFORCED | Material and Color | Cross Section | Part Number* | Dimensions w × h [†] (in) (mm) | Minimum Pulley Ø (in) (mm) | | Working Load @ Percent Tension | | | | | | | | Weight | |
|-------------------|--------------------|---------------|--------------|--|-------------------------------|----|--------------------------------|------|-------|------|-------|------|-------|------|--------|-------|
| | | | | | | | 4% | | 6% | | 8% | | 10% | | lbs/ft | kg/m |
| | | | | | | | (lbs) | (N) | (lbs) | (N) | (lbs) | (N) | (lbs) | (N) | | |
| Eagle® Blue 80 EC | 6mm × 4mm | 4928009 | | 6.5 × 4 | 1.1 | 28 | 0.8 | 3.7 | 1.5 | 6.7 | 2.1 | 9.4 | 2.7 | 12.1 | 0.015 | 0.023 |
| Eagle Clear 80 EC | 6mm × 4mm | 4927009 | | 6.5 × 4 | 1.1 | 28 | 0.8 | 3.7 | 1.5 | 6.7 | 2.1 | 9.4 | 2.7 | 12.1 | 0.015 | 0.023 |
| Eagle Clear 85 | 6mm × 4mm | L04C850604 | | 6.5 × 4 | 1.26 | 32 | 1 | 4.5 | 1.7 | 7.6 | 2.4 | 10.7 | 3 | 13.5 | 0.016 | 0.024 |
| Eagle Blue 85 | 6mm × 4mm | L04BL850604 | | 6.5 × 4 | 1.25 | 32 | 1 | 4.5 | 1.7 | 7.6 | 2.3 | 10.7 | 3 | 13.5 | 0.016 | 0.024 |
| Eagle Blue 80 EC | 8mm × 5mm | 4928010 | | 8 × 5 | 1.38 | 35 | 1.3 | 5.7 | 2.4 | 10.5 | 3.3 | 14.6 | 4.2 | 18.9 | 0.024 | 0.035 |
| Eagle Clear 80 EC | 8mm × 5mm | 4927010 | | 8 × 5 | 1.38 | 35 | 1.3 | 5.7 | 2.4 | 10.5 | 3.3 | 14.6 | 4.2 | 18.9 | 0.024 | 0.035 |
| Eagle Opaque 80 | 8mm × 5mm | 4940006 | | 8 × 5 | 1.38 | 35 | 1.6 | 7.1 | 3.3 | 14.7 | 5.2 | 23.1 | 7 | 31.2 | 0.026 | 0.039 |
| Eagle Red 85 | 8mm × 5mm | L04R8585M | | 8 × 5 | 1.57 | 40 | 1.5 | 6.8 | 2.6 | 11.5 | 3.6 | 16.2 | 4.6 | 20.5 | 0.025 | 0.038 |
| Eagle Blue 85 | 8mm × 5mm | L04BL8585M | | 8 × 5 | 1.57 | 40 | 1.5 | 6.8 | 2.6 | 11.5 | 3.6 | 16.2 | 4.6 | 20.5 | 0.025 | 0.038 |
| Eagle Red 90 | 8mm × 5mm | 4940027 | | 8 × 5 | 2 | 50 | 10.8 | 48.1 | 15.6 | 69.3 | 19.6 | 87.2 | 22.9 | 102 | 0.026 | 0.039 |
| Eagle White 40D | 8mm × 5mm | L04BY400805 | | 8 × 5 | 2.36 | 60 | 6 | 26.5 | 10.2 | 45.3 | 14 | 62.4 | 17.3 | 77.2 | 0.025 | 0.037 |
| Eagle Blue 80 EC | 10mm × 4mm T-Top | 4928011 | | 10 × 4 | 1.1 | 28 | 1 | 4.6 | 1.9 | 8.5 | 2.7 | 11.8 | 3.4 | 15.3 | 0.019 | 0.028 |
| Eagle Clear 80 EC | 10mm × 4mm T-Top | 4927011 | | 10 × 4 | 1.1 | 28 | 1 | 4.6 | 1.9 | 8.5 | 2.7 | 11.8 | 3.4 | 15.3 | 0.019 | 0.028 |

Z/10, 3L Cross Section

Link V Belting



| LINK BELTING | Part Number | | Cross Section | Minimum Pulley Ø (in) (mm) | Max Product Weight w/Idlers (lbs) (kg) | Max Product Weight w/UHMW (lbs) (kg) |
|----------------|-------------|---------|---------------|-------------------------------|--|--|
| | 25' | 10m | | | | |
| Tango™ Belting | 0470625 | 0470633 | Z/10 | 45 | 230 | 105 |

V Belting

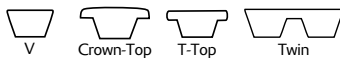

| NON-REINFORCED | Material and Color | Cross Section | Part Number* | Dimensions w × h [†] (in) (mm) | Minimum Pulley Ø (in) (mm) | | Working Load @ Percent Tension | | | | | | | | Weight | |
|-------------------|--------------------|---------------|--------------|--|-------------------------------|----|--------------------------------|-------|-------|-------|-------|-------|-------|-------|--------|-------|
| | | | | | | | 4% | | 6% | | 8% | | 10% | | lbs/ft | kg/m |
| | | | | | | | (lbs) | (N) | (lbs) | (N) | (lbs) | (N) | (lbs) | (N) | | |
| Eagle Orange 85 | 3L | 1032030 | | 3/8 × 7/32 | 1.75 | 44 | 2.1 | 9.5 | 3.6 | 16.1 | 5.1 | 22.6 | 6.4 | 28.6 | 0.035 | 0.053 |
| Eagle Clear 85 | 3L | 4912063 | | 3/8 × 7/32 | 1.75 | 44 | 2.2 | 9.7 | 3.7 | 16.5 | 5.2 | 23.1 | 6.6 | 29.3 | 0.035 | 0.053 |
| Eagle Blue 85 | 3L | L04BL853L | | 3/8 × 7/32 | 1.75 | 45 | 2.1 | 9.5 | 3.6 | 16.1 | 5.1 | 22.6 | 6.4 | 28.6 | 0.035 | 0.053 |
| Eagle Clear 95 | 3L | 4911063 | | 3/8 × 7/32 | 2.19 | 56 | 4 | 17.9 | 6.6 | 29.2 | 8.8 | 39.3 | 10.8 | 47.9 | 0.036 | 0.054 |
| Eagle Orange 85 | 3L Crown-Top | 1032032 | | 9/16 × 1/4 | 2 | 51 | 3 | 13.2 | 5 | 22.4 | 7.1 | 31.5 | 9 | 39.9 | 0.049 | 0.073 |
| Eagle Orange 85 | 3L T-Top | 1032031 | | 9/16 × 19/64 | 2.38 | 60 | 3.5 | 15.7 | 6 | 26.5 | 8.4 | 37.2 | 10.6 | 47.2 | 0.058 | 0.087 |
| Eagle Clear 85 | 3L T-Top | 4912064 | | 9/16 × 19/64 | 2.38 | 60 | 3.6 | 16.1 | 6.1 | 27.2 | 8.6 | 38.2 | 10.9 | 48.3 | 0.058 | 0.087 |
| Eagle Orange 85 | 3L Twin | 1032033 | | 15/16 × 17/64 | 2.13 | 54 | 5.9 | 26.2 | 10 | 44.5 | 14 | 62.4 | 17.8 | 79 | 0.098 | 0.145 |
| Eagle Clear 85 | 3L Twin | 4912065 | | 15/16 × 17/64 | 2.13 | 54 | 6 | 26.9 | 10.2 | 45.6 | 14.4 | 63.9 | 18.2 | 81 | 0.098 | 0.145 |
| Eagle Clear 95 | 3L Twin | 4911065 | | 15/16 × 17/64 | 2.5 | 64 | 11.1 | 49.5 | 18.1 | 80.6 | 24.4 | 108.5 | 29.7 | 132.2 | 0.1 | 0.149 |
| Eagle Blue 80 EC | Z/10 | 4928012 | | 10 × 6.5 | 1.79 | 46 | 2.1 | 9.2 | 3.8 | 16.8 | 5.3 | 23.5 | 6.8 | 30.3 | 0.038 | 0.057 |
| Eagle Clear 80 EC | Z/10 | 4927012 | | 10 × 6.5 | 1.79 | 46 | 2.1 | 9.2 | 3.8 | 16.8 | 5.3 | 23.5 | 6.8 | 30.3 | 0.038 | 0.057 |
| Eagle Opaque 80 | Z/10 | 4940008 | | 10 × 6.5 | 1.79 | 46 | 2.5 | 11.3 | 5.2 | 23.3 | 8.3 | 36.8 | 11.1 | 49.5 | 0.041 | 0.062 |
| Eagle Orange 85 | Z/10 | 4940114 | | 10 × 6.5 | 1.88 | 52 | 2.5 | 10.9 | 4.2 | 18.5 | 5.8 | 26 | 7.4 | 32.9 | 0.041 | 0.061 |
| Eagle Clear 85 | Z/10 | 4940118 | | 10 × 6.5 | 2.05 | 52 | 2.5 | 11.2 | 4.3 | 19 | 6 | 26.6 | 7.6 | 33.7 | 0.041 | 0.061 |
| Eagle Ivory 85 | Z/10 | L04I85Z | | 10 × 6.5 | 2.05 | 52 | 6.9 | 30.8 | 10.6 | 47 | 13.9 | 61.7 | 16.8 | 74.8 | 0.04 | 0.06 |
| Eagle Blue 85 | Z/10 | L04BL85Z | | 10 × 6.5 | 1.88 | 52 | 2.5 | 10.8 | 4.2 | 18.3 | 5.8 | 25.6 | 7.4 | 32.5 | 0.041 | 0.061 |
| Eagle Green 89 | Z/10 | L04G89Z | | 10 × 6.5 | 2.3 | 59 | 12.4 | 55.3 | 19 | 84.5 | 24.9 | 110.6 | 30 | 133.4 | 0.04 | 0.06 |
| Eagle Red 90 | Z/10 | 4940028 | | 10 × 6.5 | 2.5 | 65 | 16.9 | 75.2 | 24.3 | 108.3 | 30.6 | 136.3 | 35.9 | 159.5 | 0.041 | 0.061 |
| Eagle White 40D | Z/10 | L04BY40Z | | 10 × 6.5 | 3.07 | 78 | 9.4 | 41.9 | 16.1 | 71.6 | 22.2 | 98.7 | 27.4 | 122 | 0.039 | 0.058 |
| Eagle Blue 55D | Z/10 | L04BY55Z | | 10 × 6.5 | 3.33 | 85 | 37.1 | 165.2 | 54.6 | 242.8 | 68.5 | 304.8 | 79.3 | 352.9 | 0.041 | 0.061 |
| REINFORCED | Material and Color | Cross Section | Part Number* | Dimensions w × h [†] (in) (mm) | Minimum Pulley Ø (in) (mm) | | Working Load @ Percent Tension | | | | | | | | Weight | |
| | | | | | | | 1% | | 2% | | 3% | | 4% | | lbs/ft | kg/m |
| | | | | | | | (lbs) | (N) | (lbs) | (N) | (lbs) | (N) | (lbs) | (N) | | |
| Eagle Beige 95 | 3L | 4940070 | | 3/8 × 7/32 | 2.63 | 67 | 11.4 | 50.5 | 26.5 | 117.9 | 38.9 | 172.9 | 47.8 | 212.8 | 0.036 | 0.054 |
| Eagle Hyfen 85 | 3L Twin | 5299010 | | 15/16 × 17/64 | 2.92 | 74 | 15.5 | 68.8 | 21.8 | 96.8 | 28.4 | 126.4 | 34.7 | 154.4 | 0.095 | 0.142 |
| Eagle Orange 85 | Z/10 | 4940065 | | 10 × 6.5 | 2.38 | 65 | 2.4 | 10.7 | 5.7 | 25.3 | 9.1 | 40.4 | 12 | 53.3 | 0.04 | 0.06 |
| Eagle Ivory 85 | Z/10 | L04I85ZR | | 10 × 6.5 | 2.56 | 65 | 3.1 | 13.7 | 9.3 | 41.3 | 14.8 | 65.7 | 18.8 | 83.8 | 0.04 | 0.06 |

Trackstar® V Belt Guides

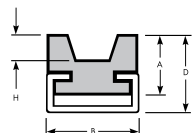

| Belt Section | Part Numbers | | | | Channel Type | A | B | D | H |
|------------------------------------|--------------------|-------------------------|------------------|-----------|--------------|------|------|-----|------|
| | Galvanized Channel | Stainless Steel Channel | Aluminum Channel | UHMW Only | | | | | |
| V Belt Guide with Mounting Channel | GB2000-3G | GB2000-3S | GB2000-3A | GB2000 | C3 | 0.59 | 0.79 | 0.8 | 0.16 |

Trackstar Guides are stocked in North America and supplied in 120" standard lengths. Subject to a minimum order quantity. Dimensions are in inches and are for reference only.

A Cross Section

Link V Belting

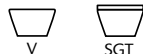

| LINK BELTING | Part Number | | | | Cross Section | Minimum Pulley Ø | | Max Product Weight w/Idlers | | Max Product Weight w/UHMW | |
|-------------------------|-------------|------------|-----------|---------|---------------|------------------|------|-----------------------------|------|---------------------------|------|
| | 25' | 100'/30.5m | 10m | 30m | | (in) | (mm) | (lbs) | (kg) | (lbs) | (kg) |
| Tango™ Belting | 0470725 | | 0470733 | | A | 3.0 | 76 | 340 | 154 | 115 | 52 |
| Tango SuperGrip Top PU | | 0430101 | | | A | 3.0 | 76 | 200 | 91 | 65 | 30 |
| Tango SuperGrip Top PVC | | 0409100 | | | A | 3.0 | 76 | 200 | 91 | 65 | 30 |
| Tango Friction Top® | | 0408081 | | | A | 2.5 | 64 | 200 | 91 | 65 | 30 |
| Tango Bridge Top™ | | 0499020 | | | A | 3.0 | 76 | 340 | 154 | 115 | 52 |
| PowerTwist® Antistatic | 0408505 | 0408501 | 040850010 | 0408500 | A | 3.0 | 76 | 340 | 154 | 115 | 52 |



V Belting

| NON-REINFORCED | Material and Color | Cross Section | Part Number* | Dimensions w × h † | | Minimum Pulley Ø | | Working Load @ Percent Tension | | | | | | | | Weight | |
|----------------|-------------------------|-------------------|--------------|--------------------|------------|------------------|------|--------------------------------|-------|------|-------|--------|-------|-------|-------|--------|-------|
| | | | | (in) | (mm) | (in) | (mm) | 4% | 6% | 8% | 10% | lbs/ft | kg/m | | | | |
| | Eagle® Blue 80 EC | A/13 | 4928013 | | 13 × 8 | 2.2 | 56 | 3.4 | 14.9 | 6.1 | 27.3 | 8.6 | 38.2 | 11.1 | 49.3 | 0.062 | 0.092 |
| | Eagle Clear 80 EC | A/13 | 4927013 | | 13 × 8 | 2.2 | 56 | 3.4 | 14.9 | 6.1 | 27.3 | 8.6 | 38.2 | 11.1 | 49.3 | 0.062 | 0.092 |
| | Eagle Blue 80 MD | A/13 | 4941108 | 1/2 × 5/16 | 13 × 8 | 2.2 | 56 | 2.8 | 12.6 | 4.8 | 21.5 | 6.8 | 30.4 | 8.8 | 38.9 | 0.061 | 0.091 |
| | Eagle Opaque 80 | A/13 | 4940009 | 1/2 × 5/16 | 13 × 8 | 2.2 | 56 | 4.1 | 18.1 | 8.4 | 37.3 | 13.2 | 58.8 | 17.8 | 79.2 | 0.066 | 0.099 |
| | Eagle Orange 85 | A/13 | 1032038 | 1/2 × 5/16 | 13 × 8 | 2.5 | 64 | 4 | 17.6 | 6.7 | 29.9 | 9.4 | 41.9 | 11.9 | 53.1 | 0.066 | 0.098 |
| | Eagle Clear 85 | A/13 | 4912066 | 1/2 × 5/16 | 13 × 8 | 2.5 | 64 | 4.1 | 18.1 | 6.9 | 30.6 | 9.7 | 43 | 12.2 | 54.4 | 0.066 | 0.098 |
| | Eagle Ivory 85 | A/13 | L04I85A | 1/2 × 5/16 | 13 × 8 | 2.52 | 64 | 11.2 | 50 | 17.2 | 76.4 | 22.5 | 100.2 | 27.3 | 121.4 | 0.065 | 0.096 |
| | Eagle Blue 85 | A/13 | L04BL85A | 1/2 × 5/16 | 13 × 8 | 2.5 | 64 | 4 | 18 | 6.8 | 30.4 | 9.5 | 42.7 | 12 | 54.1 | 0.066 | 0.098 |
| | Eagle Green 89 | A/13 | L04G89A | 1/2 × 5/16 | 13 × 8 | 2.83 | 72 | 20.2 | 89.8 | 30.8 | 137.2 | 40.4 | 179.6 | 48.7 | 216.6 | 0.066 | 0.098 |
| | Eagle Red 90 | A/13 | 4940029 | 1/2 × 5/16 | 13 × 8 | 3.13 | 80 | 27 | 120.2 | 38.9 | 173.1 | 49 | 217.9 | 57.3 | 255 | 0.066 | 0.098 |
| | Eagle Beige 95 | A/13 | L04BE95A | 1/2 × 5/16 | 13 × 8 | 3.1 | 80 | 16.6 | 73.8 | 24.8 | 110.3 | 32 | 142.5 | 38.4 | 170.7 | 0.068 | 0.101 |
| | Eagle Clear 95 | A/13 | 4911066 | 1/2 × 5/16 | 13 × 8 | 3.13 | 79 | 7.5 | 33.2 | 12.2 | 54.2 | 16.4 | 72.9 | 20 | 88.9 | 0.067 | 0.1 |
| | Eagle White 40D | A/13 | L04BY40A | 1/2 × 5/16 | 13 × 8 | 3.78 | 96 | 15.5 | 69.1 | 26.6 | 118.1 | 36.6 | 162.8 | 45.2 | 201.2 | 0.064 | 0.096 |
| | Eagle Blue 55D | A/13 | L04BY55A | 1/2 × 5/16 | 13 × 8 | 4.09 | 104 | 60.3 | 268.3 | 88.6 | 394.3 | 111.3 | 495 | 128.8 | 573.1 | 0.066 | 0.098 |
| | Eagle Red 85 CXF | A/13 | 4924320 | 0.50 × 0.41 | 13 × 10.54 | 3.28 | 83 | 4.6 | 20.5 | 7.3 | 32.3 | 9.9 | 44 | 12.3 | 54.8 | 0.091 | 0.135 |
| | Eagle Ivory 85 SGT PU | A/13 | 493030030M | 0.50 × 0.47 | 13 × 12.06 | 3.28 | 83 | 11.2 | 50 | 17.2 | 76.4 | 22.5 | 100.2 | 27.3 | 121.4 | 0.085 | 0.127 |
| | Eagle Ivory 85 SGT PVC | A/13 | L04I85ASG | 0.50 × 0.53 | 13 × 13.51 | 3.28 | 83 | 11.2 | 50 | 17.2 | 76.4 | 22.5 | 100.2 | 27.3 | 121.4 | 0.095 | 0.142 |
| | Eagle Ivory 85 SGT TPE | A/13 | 493120030M | 0.50 × 0.48 | 13 × 12.34 | 3.28 | 83 | 11.2 | 50 | 17.2 | 76.4 | 22.5 | 100.2 | 27.3 | 121.4 | 0.028 | 0.124 |
| | Eagle Green 89 SGT PVC | A/13 | L04G89ASG | 0.50 × 0.53 | 13 × 13.51 | 3.69 | 94 | 20.2 | 89.8 | 30.8 | 137.2 | 40.4 | 179.6 | 48.7 | 216.6 | 0.096 | 0.143 |
| | Eagle Red 90 SGT PVC | A/13 | L04R90ASG | 0.50 × 0.53 | 13 × 13.51 | 3.69 | 94 | 27 | 120.2 | 38.9 | 173.1 | 49 | 217.9 | 57.3 | 255 | 0.096 | 0.143 |
| | Eagle White 40D SGT PVC | A/13 | L04BY40ASG | 0.50 × 0.53 | 13 × 13.51 | 5.34 | 136 | 15.5 | 69.1 | 26.6 | 118.1 | 36.6 | 162.8 | 45.2 | 201.2 | 0.095 | 0.141 |
| | Eagle Orange 85 | A/13 Hi-Ridge-Top | 1032040 | 1/2 × 5/8 | | 5 | 127 | 5.5 | 24.7 | 9.4 | 41.8 | 13.2 | 58.7 | 16.7 | 74.3 | 0.092 | 0.137 |
| | Eagle Clear 85 | A/13 Hi-Ridge-Top | 4911102 | 1/2 × 5/8 | | 5 | 127 | 5.3 | 23.7 | 9 | 40.1 | 12.7 | 56.3 | 16 | 71.3 | 0.086 | 0.128 |
| | Eagle Orange 85 | A/13 Lo-Ridge-Top | 1032039 | 1/2 × 7/16 | | 3.5 | 89 | 4.3 | 19.1 | 7.3 | 32.4 | 10.2 | 45.4 | 12.9 | 57.5 | 0.071 | 0.106 |
| | Eagle Clear 85 | A/13 Lo-Ridge-Top | 4912067 | 1/2 × 7/16 | | 3.5 | 89 | 4.3 | 19.3 | 7.3 | 32.6 | 10.3 | 45.8 | 13 | 58 | 0.07 | 0.104 |
| | Eagle Green 89 | A/13 Ridge-Top | L04G89AX | | 13 × 16 | 5.67 | 144 | 33 | 146.8 | 50.4 | 224.3 | 66 | 293.6 | 79.6 | 354.1 | 0.107 | 0.159 |
| | Eagle Orange 85 | A Twin | 1032041 | 1-3/16 × 5/16 | | 2.5 | 64 | 9.3 | 41.4 | 15.8 | 70.2 | 22.1 | 98.5 | 28.1 | 124.8 | 0.154 | 0.23 |
| | Eagle Clear 85 | A Twin | 4912068 | 1-3/16 × 5/16 | | 2.5 | 64 | 9.6 | 42.5 | 16.2 | 72 | 22.7 | 100.9 | 28.7 | 127.9 | 0.154 | 0.23 |
| | Eagle Orange 85 | AA | 1232550 | 1/2 × 13/32 | | 3.25 | 83 | 5.6 | 25.1 | 9.6 | 42.5 | 13.4 | 59.6 | 17 | 75.5 | 0.093 | 0.139 |
| REINFORCED | Material and Color | Cross Section | Part Number* | Dimensions w × h † | | Minimum Pulley Ø | | Working Load @ Percent Tension | | | | | | | | Weight | |
| | Eagle Opaque 80 | A/13 | L04OP80AR | 1/2 × 5/16 | 13 × 8 | 3.15 | 80 | 5.9 | 26.3 | 16 | 71.1 | 24 | 106.9 | 29.4 | 130.7 | 0.066 | 0.099 |
| | Eagle Orange 85 | A/13 | 4940066 | 1/2 × 5/16 | 13 × 8 | 3.13 | 80 | 3.9 | 17.3 | 9.3 | 41.2 | 14.8 | 65.8 | 19.5 | 86.6 | 0.065 | 0.097 |
| | Eagle Ivory 85 | A/13 | L04I85AR | 1/2 × 5/16 | 13 × 8 | 3.15 | 80 | 4.9 | 21.9 | 14.8 | 66 | 23.6 | 105.1 | 30.1 | 134.1 | 0.065 | 0.096 |
| | Eagle Green 89 | A/13 | L04G89AR | 1/2 × 5/16 | 13 × 8 | 3.15 | 80 | 3.8 | 16.8 | 14.3 | 63.5 | 53.9 | 239.9 | 88.7 | 394.8 | 0.065 | 0.096 |
| | Eagle Beige 95 | A/13 | 4940075 | 1/2 × 5/16 | 13 × 8 | 3.78 | 96 | 20.9 | 93 | 48.8 | 217.1 | 71.6 | 318.4 | 88.1 | 391.7 | 0.067 | 0.099 |
| | Eagle Beige 95 | A/13 Cogged | 4940071 | 1/2 × 5/16 | 13 × 8 | 2.78 | 71 | 20.9 | 93 | 48.8 | 217.1 | 71.6 | 318.4 | 88.1 | 391.7 | 0.067 | 0.099 |
| | Eagle Hyfen 95 | A | 5260200 | 1/2 × 3/8 | | 3.75 | 95 | 18.3 | 81.3 | 26.6 | 118.2 | 34.1 | 151.8 | 41.3 | 183.6 | 0.077 | 0.114 |
| | Eagle Hyfen 95 | A Cogged | 5220000 | 1/2 × 3/8 | | 2.75 | 70 | 18.3 | 81.3 | 26.6 | 118.2 | 34.1 | 151.8 | 41.3 | 183.6 | 0.077 | 0.114 |
| | Eagle Hyfen 85 | A Ridge-Top | 5299007 | 1/2 × 9/16 | | 6.19 | 157 | 17.4 | 77.4 | 25.1 | 111.5 | 33.8 | 150.2 | 42.8 | 190.2 | 0.1 | 0.148 |
| | Eagle Hyfen 85 | A Twin | 5299019 | 1-3/16 × 5/16 | | 3.44 | 87 | 45.5 | 202.2 | 34.4 | 153.2 | 44.9 | 199.9 | 54.9 | 244.2 | 0.151 | 0.224 |
| | Eagle Hyfen 85 CXF | A | 5260520 | 0.50 × 0.51 | | 4.53 | 115 | 17.4 | 77.4 | 25.1 | 111.5 | 33.8 | 150.2 | 42.8 | 190.2 | 0.103 | 0.153 |
| | Eagle Hyfen 85 CXR | A | 5260525 | 1.19 × 0.41 | | 4.53 | 115 | 17.4 | 77.4 | 25.1 | 111.5 | 33.8 | 150.2 | 42.8 | 190.2 | 0.088 | 0.131 |
| | Eagle Hyfen 85 CXF | A Twin | 5260572 | 0.50 × 0.51 | | 4.53 | 115 | 45.5 | 202.2 | 34.4 | 153.2 | 44.9 | 199.9 | 54.9 | 244.2 | 0.203 | 0.302 |
| | Eagle Hyfen 85 CXR | A Twin | 5260577 | 1.19 × 0.41 | | 4.53 | 115 | 45.5 | 202.2 | 34.4 | 153.2 | 44.9 | 199.9 | 54.9 | 244.2 | 0.174 | 0.259 |
| | Eagle Ivory 85 SGT PU | A/13 | 493060030M | 0.50 × 0.47 | 13 × 12.06 | 4.11 | 104 | 4.9 | 21.9 | 14.8 | 66 | 23.6 | 105.1 | 30.1 | 134.1 | 0.085 | 0.127 |
| | Eagle Ivory 85 SGT PVC | A/13 | L04I85ARSG | 0.50 × 0.53 | 13 × 13.51 | 4.11 | 104 | 4.9 | 21.9 | 14.8 | 66 | 23.6 | 105.1 | 30.1 | 134.1 | 0.095 | 0.142 |
| | Eagle Ivory 85 SGT TPE | A/13 | 493150030M | 0.50 × 0.48 | 13 × 12.34 | 4.11 | 104 | 4.9 | 21.9 | 14.8 | 66 | 23.6 | 105.1 | 30.1 | 134.1 | 0.084 | 0.124 |

* Standard package length 100' / 30.5m

† w (width) is the widest part of the belt. h (height) is the tallest part of the belt, including the belting top surface. Dimensions are for reference only.

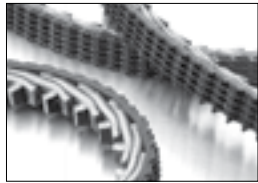

Tango SuperGrip Top



Tango Friction Top



Tango Bridge Top

Trackstar® V Belt Guides

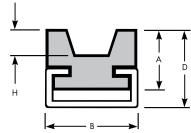

| | V Belt Size | Part Numbers | | | | Channel Type | A | B | D | H |
|------------------------------------|-------------|--------------------|-------------------------|------------------|-----------|--------------|------|------|------|-----|
| | | Galvanized Channel | Stainless Steel Channel | Aluminum Channel | UHMW Only | | | | | |
| V Belt Guide with Mounting Channel | A | GB2001-3G | GB2001-3S | GB2001-3A | GB2001 | C3 | 0.59 | 0.79 | 0.8 | 0.2 |
| V Belt Guide with Mounting Channel | A Twin | GB2006-5G | GB2006-5S | | GB2006 | C5 | 0.59 | 1.42 | 0.84 | 0.2 |

Trackstar Guides are stocked in North America and supplied in 120" standard lengths. Subject to a minimum order quantity. Dimensions are in inches and are for reference only.

T-Max® Tensioner/Pulley Assembly



| Assembly Part Number | Component | Component Part Number | |
|----------------------|-----------|-----------------------|--|
| FS0578 | Tensioner | RT1001 | Force Range: 0-30 lb |
| | Pulley | VA3001 | |
| FS0581ZF | Tensioner | RT1001 | Force Range: 0-30 lb Zerk fitted to apply grease to the spring cavity. |
| | Pulley | VA3001 | |
| FS0577ZF | Tensioner | RT1001-L | Force Range: 0-30 lb Zerk fitted to apply grease to the shaft area. |
| | Pulley | VX3012 | |
| FS0524 | Tensioner | RT3001 | Force Range: 0-42 lb |
| | Pulley | VA3001 | |

B Cross Section

Link V Belting



| LINK BELTING | Part Number | | | | Cross Section | Minimum Pulley Ø | | Max Product Weight w/Idlers | | Max Product Weight w/UHMW | |
|-------------------------------------|-------------|------------|-----------|---------|---------------|------------------|------|-----------------------------|------|---------------------------|------|
| | 25' | 100'/30.5m | 10m | 30m | | (in) | (mm) | (lbs) | (kg) | (lbs) | (kg) |
| Tango™ Belting | 0470825 | | 0470833 | | B | 5.5 | 140 | 612 | 278 | 204 | 93 |
| Tango Super Grip Top PU | | 0435101 | | | B | 5.5 | 140 | 400 | 181 | 135 | 61 |
| Tango Super Grip Top PVC | | 0409200 | | | B | 5.5 | 140 | 400 | 181 | 135 | 61 |
| Tango Friction Top® | 0405082 | 0408082 | | | B | 5.0 | 127 | 400 | 181 | 135 | 61 |
| Tango Bridge Top™ | 0499021 | 0499002 | | | B | 5.5 | 140 | 612 | 278 | 204 | 93 |
| Tango Reduced Contact Surface (RCS) | | 0419300 | | | B | 5.5 | 140 | 612 | 278 | 204 | 93 |
| PowerTwist® Roller Drive™ | 0410300-25 | 0410300 | 0411301 | 0411300 | B | 5.0 | 127 | 275 | 125 | 95 | 43 |
| PowerTwist Antistatic | 0408605 | 0408601 | 040860010 | 0408600 | B | 5.5 | 140 | 612 | 278 | 204 | 93 |

V Belting

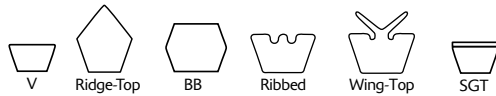

| NON-REINFORCED | Material and Color | Cross Section | Part Number* | Dimensions w × h† | | Minimum Pulley Ø | | Working Load @ Percent Tension | | | | | | | | Weight | |
|-------------------------|--------------------|---------------|---------------|-------------------|------|------------------|----------|--------------------------------|----------|----------|----------|----------|----------|-----------|---------|--------|------|
| | | | | (in) | (mm) | (in) | (mm) | 4% (lbs) | 4% (N) | 6% (lbs) | 6% (N) | 8% (lbs) | 8% (N) | 10% (lbs) | 10% (N) | lbs/ft | kg/m |
| Eagle® Blue 80 EC | B/17 | 4928014 | | 17 × 11.5 | 3.17 | 81 | 6.1 | 27.3 | 11.2 | 49.9 | 15.7 | 69.9 | 20.3 | 90.2 | 0.113 | 0.168 | |
| Eagle Clear 80 EC | B/17 | 4927014 | | 17 × 11.5 | 3.17 | 81 | 6.1 | 27.3 | 11.2 | 49.9 | 15.7 | 69.9 | 20.3 | 90.2 | 0.113 | 0.168 | |
| Eagle Blue 80 MD | B/17 | 4941109 | 21/32 × 7/16 | 17 × 11.5 | 3.17 | 81 | 5 | 22 | 8.4 | 37.3 | 11.8 | 52.6 | 15.1 | 67 | 0.113 | 0.168 | |
| Eagle Opaque 80 | B/17 | 4940010 | 21/32 × 7/16 | 17 × 11.5 | 3.17 | 81 | 7.4 | 33.1 | 15.3 | 68 | 24.1 | 107.2 | 32.5 | 144.5 | 0.121 | 0.18 | |
| Eagle Orange 85 | B/17 | 1032047 | 11/16 × 13/32 | 17.5 × 10 | 3.25 | 83 | 7 | 31.1 | 11.8 | 52.7 | 16.6 | 73.9 | 21.1 | 93.7 | 0.116 | 0.172 | |
| Eagle Clear 85 | B/17 | 4912069 | 11/16 × 13/32 | 17.5 × 10 | 3.25 | 83 | 7.2 | 31.9 | 12.1 | 54 | 17 | 75.8 | 21.6 | 96 | 0.116 | 0.172 | |
| Eagle Ivory 85 | B/17 | L04I85B | 21/32 × 7/16 | 17 × 11.5 | 3.62 | 92 | 20.6 | 91.6 | 31.4 | 139.8 | 41.2 | 183.4 | 49.9 | 222.2 | 0.118 | 0.175 | |
| Eagle Blue 85 | B/17 | L04BL85B | 21/32 × 7/16 | 17 × 11.5 | 3.25 | 92 | 7.3 | 31 | 12.4 | 52.5 | 17.4 | 73.7 | 22 | 93.4 | 0.121 | 0.18 | |
| Eagle Green 89 | B/17 | L04G89B | 21/32 × 7/16 | 17 × 11.5 | 4.07 | 104 | 37 | 164.4 | 56.4 | 251.1 | 73.9 | 328.7 | 89.1 | 396.4 | 0.12 | 0.178 | |
| Eagle Clear 95 | B/17 | 4911069 | 11/16 × 13/32 | 17.5 × 10 | 4.13 | 105 | 13.2 | 58.6 | 21.5 | 95.5 | 28.9 | 128.6 | 35.2 | 156.8 | 0.119 | 0.177 | |
| Eagle White 40D | B/17 | L04BY40B | 21/32 × 7/16 | 17 × 11 | 5.2 | 132 | 27.6 | 122.6 | 47.1 | 209.5 | 64.9 | 288.9 | 80.3 | 357 | 0.114 | 0.17 | |
| Eagle Blue 55D | B/17 | L04BY55B | 21/32 × 7/16 | 17 × 11.5 | 5.89 | 150 | 110.4 | 491 | 162.2 | 721.6 | 203.6 | 905.8 | 235.8 | 1048.7 | 0.121 | 0.18 | |
| Eagle Red 90 | B/17 | 4940030 | 21/32 × 7/16 | 17 × 11.5 | 4.5 | 115 | 49.3 | 219.3 | 71 | 315.9 | 89.4 | 397.5 | 104.6 | 465.2 | 0.12 | 0.178 | |
| Eagle Beige 95 | B/17 | L04BE95B | 21/32 × 7/16 | 17 × 11.5 | 4.5 | 115 | 30.4 | 135.1 | 45.4 | 201.9 | 58.6 | 260.8 | 70.2 | 312.3 | 0.124 | 0.184 | |
| Eagle Orange 85 | B/17 Ribbed | 1032046 | 11/16 × 13/32 | 17.5 × 10 | 3.25 | 83 | 6.5 | 28.7 | 10.9 | 48.6 | 15.3 | 68.3 | 19.4 | 86.5 | 0.107 | 0.159 | |
| Eagle Green 89 | B/17 Ridge-Top | L04G89BX | | 17 × 19.5 | 6.91 | 176 | 53.7 | 238.9 | 82 | 364.9 | 107.4 | 477.7 | 129.5 | 576.1 | 0.174 | 0.259 | |
| Eagle Orange 85 | B/17 Wing-Top | 1032048 | 11/16 × 5/8 | | 5 | 127 | 7.8 | 34.6 | 13.2 | 58.7 | 18.5 | 82.3 | 23.5 | 104.3 | 0.129 | 0.192 | |
| Eagle Orange 85 | BB | 1232600 | 11/16 × 9/16 | | 4.5 | 114 | 10.3 | 45.8 | 17.5 | 77.7 | 24.5 | 109 | 31.1 | 138.1 | 0.171 | 0.254 | |
| Eagle Clear 95 | BB | 4911070 | 11/16 × 9/16 | | 5.63 | 143 | 19.4 | 86.5 | 31.7 | 140.9 | 42.6 | 189.6 | 52 | 231.1 | 0.175 | 0.26 | |
| Eagle Red 85 CXF | B/17 | 4924330 | 0.69 × 0.51 | 17.5 × 12.54 | 4.28 | 109 | 8.1 | 36.1 | 12.8 | 57 | 17.4 | 77.5 | 21.7 | 96.7 | 0.15 | 0.223 | |
| Eagle Ivory 85 SGT PU | B/17 | 493040030M | 0.66 × 0.60 | 17 × 15.56 | 4.28 | 109 | 20.6 | 91.6 | 31.4 | 139.8 | 41.2 | 183.4 | 49.9 | 222.2 | 0.146 | 0.218 | |
| Eagle Ivory 85 SGT PVC | B/17 | L04I85BSG | 0.66 × 0.66 | 17 × 17.01 | 4.28 | 109 | 20.6 | 91.6 | 31.4 | 139.8 | 41.2 | 183.4 | 49.9 | 222.2 | 0.158 | 0.235 | |
| Eagle Ivory 85 SGT TPE | B/17 | 493130030M | 0.66 × 0.61 | 17 × 15.84 | 4.28 | 109 | 20.6 | 91.6 | 31.4 | 139.8 | 41.2 | 183.4 | 49.9 | 222.2 | 0.039 | 0.215 | |
| Eagle Green 89 SGT PVC | B/17 | L04G89BSG | 0.66 × 0.66 | 17 × 17.01 | 4.82 | 122 | 37 | 164.4 | 56.4 | 251.1 | 73.9 | 328.7 | 89.1 | 396.4 | 0.16 | 0.238 | |
| Eagle Red 90 SGT PVC | B/17 | L04R90BSG | 0.66 × 0.66 | 17 × 17.01 | 4.82 | 122 | 49.3 | 219.3 | 71 | 315.9 | 89.4 | 397.5 | 104.6 | 465.2 | 0.16 | 0.238 | |
| Eagle White 40D SGT PVC | B/17 | L04BY40BSG | 0.66 × 0.66 | 17 × 17.01 | 6.96 | 177 | 27.6 | 122.6 | 47.1 | 209.5 | 64.9 | 288.9 | 80.3 | 357 | 0.154 | 0.229 | |
| REINFORCED | Material and Color | Cross Section | Part Number* | Dimensions w × h† | | Minimum Pulley Ø | | Working Load @ Percent Tension | | | | | | | | Weight | |
| (in) | | | | (mm) | (in) | (mm) | 1% (lbs) | 1% (N) | 2% (lbs) | 2% (N) | 3% (lbs) | 3% (N) | 4% (lbs) | 4% (N) | lbs/ft | kg/m | |
| Eagle Hyfen 95 | B | 5260300 | 21/32 × 1/2 | | 5 | 127 | 26.9 | 119.6 | 39.1 | 173.8 | 50.2 | 223.3 | 60.7 | 270.1 | 0.131 | 0.196 | |
| Eagle Hyfen 95 | B Cogged | 5230000 | 21/32 × 1/2 | | 4 | 102 | 26.9 | 119.6 | 39.1 | 173.8 | 50.2 | 223.3 | 60.7 | 270.1 | 0.131 | 0.196 | |
| Eagle Hyfen 85 | B Ridge-Top | 5299009 | 21/32 × 11/16 | | 7.56 | 192 | 25.7 | 114.4 | 37 | 164.6 | 49.9 | 221.7 | 63.2 | 280.9 | 0.161 | 0.239 | |
| Eagle Opaque 80 | B/17 | L04OP80BR | 21/32 × 7/16 | 17 × 11.5 | 4.53 | 115 | 11 | 48.8 | 29.7 | 132 | 44.6 | 198.4 | 54.5 | 242.6 | 0.123 | 0.183 | |
| Eagle Orange 85 | B/17 | 4940067 | 21/32 × 7/16 | 17 × 11.5 | 4.38 | 115 | 7.1 | 31.6 | 16.9 | 75.2 | 27 | 120 | 35.5 | 158 | 0.119 | 0.177 | |
| Eagle Ivory 85 | B/17 | L04I85BR | 21/32 × 7/16 | 17 × 11.5 | 4.53 | 115 | 9 | 39.9 | 27.1 | 120.5 | 43.1 | 191.9 | 55 | 244.8 | 0.118 | 0.175 | |
| Eagle Green 89 | B/17 | 4940127 | 21/32 × 7/16 | 17 × 11.5 | 4.53 | 115 | 7 | 31.2 | 26.5 | 117.9 | 100.1 | 445.3 | 164.7 | 732.8 | 0.12 | 0.178 | |
| Eagle Beige 95 | B/17 | 4940076 | 21/32 × 7/16 | 17 × 11.5 | 5.43 | 138 | 38.8 | 172.7 | 90.6 | 403 | 132.9 | 591 | 163.5 | 727.2 | 0.124 | 0.184 | |
| Eagle Beige 95 | B/17 Cogged | 4940072 | 21/32 × 7/16 | 17 × 11.5 | 4.43 | 113 | 38.8 | 172.7 | 90.6 | 403 | 132.9 | 591 | 163.5 | 727.2 | 0.124 | 0.184 | |
| Eagle Ivory 85 | B/17 Ridge-Top | L04I85BRXH | | 17 × 19.5 | 7.68 | 195 | 13.3 | 59 | 40.1 | 178.3 | 63.8 | 283.8 | 81.4 | 362 | 0.174 | 0.259 | |
| Eagle Green 89 | B/17 Ridge-Top | L04G89BRXH | | 17 × 19.5 | 7.68 | 195 | 10.2 | 45.4 | 38.5 | 171.4 | 145.5 | 647.3 | 239.5 | 1065.1 | 0.174 | 0.259 | |
| Eagle Hyfen 85 CXF | B | 5260530 | 0.66 × 0.51 | | 5.89 | 150 | 25.7 | 114.4 | 37 | 164.6 | 49.9 | 221.7 | 63.2 | 280.9 | 0.141 | 0.21 | |
| Eagle Hyfen 85 CXR | B | 5260535 | 0.66 × 0.51 | | 5.89 | 150 | 25.7 | 114.4 | 37 | 164.6 | 49.9 | 221.7 | 63.2 | 280.9 | 0.122 | 0.181 | |
| Eagle Ivory 85 SGT PU | B/17 | 493020030M | 0.60 × 0.60 | 17 × 15.56 | 5.36 | 136 | 9 | 39.9 | 27.1 | 120.5 | 43.1 | 191.9 | 55 | 244.8 | 0.146 | 0.218 | |
| Eagle Ivory 85 SGT PVC | B/17 | L04I85BRSG | 0.66 × 0.66 | 17 × 17.01 | 5.36 | 136 | 9 | 39.9 | 27.1 | 120.5 | 43.1 | 191.9 | 55 | 244.8 | 0.158 | 0.235 | |
| Eagle Ivory 85 SGT TPE | B/17 | 493160030M | 0.66 × 0.61 | 17 × 15.84 | 5.36 | 136 | 9 | 39.9 | 27.1 | 120.5 | 43.1 | 191.9 | 55 | 244.8 | 0.144 | 0.215 | |

* Standard package length 100' / 30.5m

† w (width) is the widest part of the belt. h (height) is the tallest part of the belt, including the belting top surface. Dimensions are for reference only.

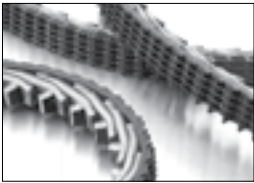

Tango SuperGrip Top



Tango Friction Top



Tango Bridge Top

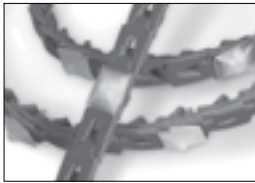

Tango RCS



PowerTwist Roller Drive

Trackstar® V Belt Guides

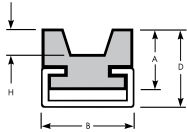

| V Belt Guide with Mounting Channel | V Belt Size | Part Numbers | | | Channel Type | A | B | D | H |
|------------------------------------|-------------|--------------------|-------------------------|-----------|--------------|------|-----|------|------|
| | | Galvanized Channel | Stainless Steel Channel | UHMW Only | | | | | |
| | B | GB2002-5G | GB2002-5S | GB2002 | C5 | 0.59 | 1.1 | 0.84 | 0.29 |

Trackstar Guides are stocked in North America and supplied in 120" standard lengths. Subject to a minimum order quantity. Dimensions are in inches and are for reference only.

T-Max® Tensioner/Pulley Assembly



| Assembly Part Number | Component | Component Part Number | |
|----------------------|-----------|-----------------------|----------------------|
| FS0566 | Tensioner | RT3001 | Force Range: 0-42 lb |
| | Pulley | VA5001 | |

C and D Cross Sections

Link V Belting



| LINK BELTING | Part Number | | | Cross Section | Minimum Pulley Ø | | Max Product Weight w/Idlers | | Max Product Weight w/UHMW | |
|--------------------------|-------------|------------|---------|---------------|------------------|------|-----------------------------|------|---------------------------|------|
| | 25' | 100'/30.5m | 10m | | (in) | (mm) | (lbs) | (kg) | (lbs) | (kg) |
| Tango™ Belting | 0470925 | | 0470933 | C | 9.0 | 229 | 815 | 370 | 275 | 125 |
| Tango Super Grip Top PU | | 0440101 | | C | 9.0 | 229 | 650 | 295 | 220 | 100 |
| Tango Super Grip Top PVC | | 0409300 | | C | 9.0 | 229 | 650 | 295 | 220 | 100 |



Tango SuperGrip Top

V Belting

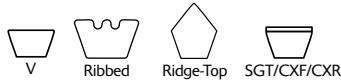

| NON-REINFORCED | | Part Number* | Dimensions w × h† (in) (mm) | | Minimum Pulley Ø (in) (mm) | | Working Load @ Percent Tension | | | | | | | | Weight | |
|-------------------------|----------------|--------------|--------------------------------|------------|-------------------------------|-----|--------------------------------|----------|----------|-----------|---------|---------|---------|----------|--------|-------|
| Material and Color | Cross Section | | | | | | 4% (lbs) | 6% (lbs) | 8% (lbs) | 10% (lbs) | 4% (kg) | 6% (kg) | 8% (kg) | 10% (kg) | lbs/ft | kg/m |
| Eagle® Orange 85 | C/22 | 1032072 | 29/32 × 17/32 | 23 × 13.5 | 4.25 | 108 | 12.2 | 54.1 | 20.6 | 91.7 | 28.9 | 128.6 | 36.6 | 163 | 0.201 | 0.3 |
| Eagle Clear 85 | C/22 | 4912072 | 29/32 × 17/32 | 23 × 13.5 | 4.25 | 108 | 12.5 | 55.5 | 21.1 | 94 | 29.6 | 131.8 | 37.5 | 167 | 0.201 | 0.3 |
| Eagle Ivory 85 | C/22 | L04I85C | 7/8 × 9/16 | 22 × 14.5 | 4.57 | 116 | 33.9 | 150.6 | 51.7 | 229.8 | 67.8 | 301.7 | 82.1 | 365.4 | 0.194 | 0.289 |
| Eagle Blue 85 | C/22 | L04BL85C | 7/8 × 9/16 | 22 × 14.5 | 4.5 | 116 | 12 | 54 | 20.3 | 91.5 | 28.5 | 128.4 | 36.2 | 162.6 | 0.199 | 0.296 |
| Eagle Green 89 | C/22 | L04G89C | 7/8 × 9/16 | 22 × 14.5 | 5.14 | 131 | 60.8 | 270.3 | 92.8 | 412.9 | 121.5 | 540.5 | 146.5 | 651.9 | 0.197 | 0.293 |
| Eagle Red 90 | C/22 | 4999306 | 7/8 × 9/16 | 22 × 14.5 | 5.75 | 145 | 81.1 | 360.8 | 116.8 | 519.7 | 147.1 | 654.1 | 172.1 | 765.4 | 0.197 | 0.293 |
| Eagle Beige 95 | C/22 | L04BE95C | 7/8 × 9/16 | 22 × 14.5 | 5.7 | 145 | 49.9 | 222.2 | 74.6 | 332 | 96.4 | 428.9 | 115.5 | 513.6 | 0.204 | 0.303 |
| Eagle Clear 95 | C/22 | 4911072 | 29/32 × 17/32 | 23 × 13.5 | 5.31 | 135 | 22.9 | 102 | 37.4 | 166.2 | 50.3 | 223.7 | 61.3 | 272.7 | 0.206 | 0.307 |
| Eagle White 40D | C/22 | L04BY40C | 7/8 × 9/16 | 22 × 14.5 | 6.85 | 174 | 46.8 | 208 | 79.9 | 355.4 | 110.2 | 490 | 136.1 | 605.6 | 0.194 | 0.288 |
| Eagle Orange 85 | C/22 Ribbed | 1032054 | 29/32 × 17/32 | | 4.25 | 108 | 11.3 | 50.3 | 19.2 | 85.3 | 26.9 | 119.7 | 34.1 | 151.7 | 0.187 | 0.279 |
| Eagle Green 89 | C/22 Ridge-Top | 4999514 | | 22 × 24.5 | 8.68 | 221 | 85.6 | 380.7 | 130.7 | 581.4 | 171.1 | 761.2 | 206.4 | 917.9 | 0.278 | 0.413 |
| Eagle Green 89 | C/22 Ridge-Top | L04G89CX | | 22 × 28.5 | 10.1 | 257 | 98.7 | 439.2 | 150.8 | 670.8 | 197.4 | 878.1 | 238.1 | 1059 | 0.32 | 0.477 |
| Eagle Ivory 85 SGT PU | C/22 | 493050030M | 0.88 × 0.72 | 22 × 18.56 | 5.28 | 134 | 33.9 | 150.6 | 51.7 | 229.8 | 67.8 | 301.7 | 82.1 | 365.4 | 0.227 | 0.338 |
| Eagle Ivory 85 SGT PVC | C/22 | L04I85CSG | 0.88 × 0.78 | 22 × 20.01 | 5.28 | 134 | 33.9 | 150.6 | 51.7 | 229.8 | 67.8 | 301.7 | 82.1 | 365.4 | 0.245 | 0.365 |
| Eagle Ivory 85 SGT TPE | C/22 | 493140030M | 0.88 × 0.73 | 22 × 18.84 | 5.28 | 134 | 33.9 | 150.6 | 51.7 | 229.8 | 67.8 | 301.7 | 82.1 | 365.4 | 0.045 | 0.334 |
| Eagle Green 89 SGT PVC | C/22 | L04G89CSG | 0.88 × 0.78 | 22 × 20.01 | 5.94 | 151 | 60.8 | 270.3 | 92.8 | 412.9 | 121.5 | 540.5 | 146.5 | 651.9 | 0.248 | 0.37 |
| Eagle Red 90 SGT PVC | C/22 | L04R90CSG | 0.88 × 0.78 | 22 × 20.01 | 5.94 | 151 | 81.1 | 360.8 | 116.8 | 519.7 | 147.1 | 654.1 | 172.1 | 765.4 | 0.248 | 0.369 |
| Eagle White 40D SGT PVC | C/22 | L04BY40CSG | 0.88 × 0.78 | 22 × 20.01 | 8.59 | 218 | 46.8 | 208 | 79.9 | 355.4 | 110.2 | 490 | 136.1 | 605.6 | 0.24 | 0.358 |
| REINFORCED | | Part Number* | Dimensions w × h† (in) (mm) | | Minimum Pulley Ø (in) (mm) | | Working Load @ Percent Tension | | | | | | | | Weight | |
| Material and Color | Cross Section | | | | | | 1% (lbs) | 2% (lbs) | 3% (lbs) | 4% (lbs) | 1% (kg) | 2% (kg) | 3% (kg) | 4% (kg) | lbs/ft | kg/m |
| Eagle Hyfen 95 | C | 5260400 | 7/8 × 5/8 | | 6.25 | 159 | 39.8 | 177.2 | 57.9 | 257.6 | 74.4 | 330.8 | 90 | 400.3 | 0.226 | 0.337 |
| Eagle Hyfen 95 | C Cogged | 5240000 | 7/8 × 5/8 | | 5.25 | 133 | 39.8 | 177.2 | 57.9 | 257.6 | 74.4 | 330.8 | 90 | 400.3 | 0.226 | 0.337 |
| Eagle Orange 85 | C/22 | 4940068 | 7/8 × 9/16 | 22 × 14.5 | 5.62 | 145 | 11.7 | 52 | 27.8 | 123.7 | 44.4 | 197.4 | 58.4 | 260 | 0.196 | 0.291 |
| Eagle Ivory 85 | C/22 | L04I85CR | 7/8 × 9/16 | 22 × 14.5 | 5.71 | 145 | 14.8 | 65.7 | 44.6 | 198.3 | 71 | 315.7 | 90.5 | 402.7 | 0.194 | 0.289 |
| Eagle Green 89 | C/22 | L04G89CR | 7/8 × 9/16 | 22 × 14.5 | 5.71 | 145 | 11.5 | 51.3 | 43.6 | 193.9 | 164.6 | 732.4 | 270.9 | 1205.1 | 0.197 | 0.293 |
| Eagle Beige 95 | C/22 | 4940077 | 7/8 × 9/16 | 22 × 14.5 | 6.85 | 174 | 63.8 | 284 | 149 | 662.7 | 218.5 | 971.9 | 268.8 | 1195.9 | 0.204 | 0.303 |
| Eagle Ivory 85 | C/22 Cogged | 4940073 | 7/8 × 9/16 | 22 × 14.5 | 5.85 | 149 | 63.8 | 284 | 149 | 662.7 | 218.5 | 971.9 | 268.8 | 1195.9 | 0.204 | 0.303 |
| Eagle Ivory 85 | C/22 Ridge-Top | 5299103 | | 22 × 24.5 | 9.65 | 245 | 21.7 | 96.6 | 65.6 | 291.7 | 104.4 | 464.3 | 133.2 | 592.4 | 0.285 | 0.424 |
| Eagle Ivory 85 | C/22 Ridge-Top | L04I85CRXH | | 22 × 28.5 | 11.22 | 285 | 24.4 | 108.5 | 73.7 | 327.7 | 117.3 | 521.6 | 149.6 | 665.4 | 0.32 | 0.477 |
| Eagle Green 89 | C/22 Ridge-Top | 4999524 | | 22 × 24.5 | 9.65 | 245 | 16.2 | 72.3 | 61.4 | 273.1 | 231.8 | 1031.3 | 381.5 | 1697 | 0.278 | 0.413 |
| Eagle Green 89 | C/22 Ridge-Top | L04G89CRXH | | 22 × 28.5 | 11.22 | 285 | 18.7 | 83.4 | 70.8 | 315.1 | 267.5 | 1189.8 | 440.1 | 1957.8 | 0.32 | 0.477 |
| Eagle Hyfen 85 CXF | C | 5260540 | 0.88 × 0.63 | | 7.7 | 196 | 38 | 169.1 | 54.7 | 243.4 | 73.7 | 327.9 | 93.4 | 415.4 | 0.241 | 0.358 |
| Eagle Hyfen 85 CXR | C | 5260545 | 0.88 × 0.63 | | 7.7 | 196 | 38 | 169.1 | 54.7 | 243.4 | 73.7 | 327.9 | 93.4 | 415.4 | 0.215 | 0.32 |
| Eagle Ivory 85 SGT PU | C/22 | 493070030M | 0.88 × 0.72 | 22 × 18.56 | 6.61 | 168 | 14.8 | 65.8 | 44.6 | 198.3 | 71 | 315.7 | 90.5 | 402.7 | 0.227 | 0.338 |
| Eagle Ivory 85 SGT PVC | C/22 | L04I85CRSG | 0.88 × 0.78 | 22 × 20.01 | 6.61 | 168 | 14.8 | 65.8 | 44.6 | 198.3 | 71 | 315.7 | 90.5 | 402.7 | 0.245 | 0.365 |
| Eagle Ivory 85 SGT TPE | C/22 | 493170030M | 0.88 × 0.73 | 22 × 18.84 | 6.61 | 168 | 14.8 | 65.8 | 44.6 | 198.3 | 71 | 315.7 | 90.5 | 402.7 | 0.224 | 0.334 |

Trackstar® V Belt Guides

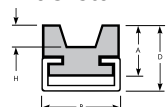

| V Belt Size | Part Numbers | | | | Channel Type | A | B | D | H |
|------------------------------------|--------------------|-------------------------|-----------|--------|--------------|------|-----|------|-----|
| | Galvanized Channel | Stainless Steel Channel | UHMW Only | | | | | | |
| V Belt Guide with Mounting Channel | C | GB2003-5G | GB2003-5S | GB2003 | C5 | 0.71 | 1.1 | 0.96 | 0.4 |

Trackstar Guides are stocked in North America and supplied in 120" standard lengths. Subject to a minimum order quantity. Dimensions are in inches and are for reference only.

D Cross Section

Link V Belting



| LINK BELTING | Part Number | | Cross Section | Minimum Pulley Ø | | Max Product Weight w/Idlers | | Max Product Weight w/UHMW | |
|----------------|-------------|---------|---------------|------------------|------|-----------------------------|------|---------------------------|------|
| | 25' | 10m | | (in) | (mm) | (lbs) | (kg) | (lbs) | (kg) |
| Tango™ Belting | 0471025 | 0471033 | D | 13.2 | 335 | 1625 | 737 | 550 | 250 |

* Standard package length 100' / 30.5m
 † w (width) is the widest part of the belt.
 h (height) is the tallest part of the belt, including the belting top surface.
 Dimensions are for reference only.

V Belting



| NON-REINFORCED | | Part Number* | Dimensions w × h† (in) (mm) | | Minimum Pulley Ø (in) (mm) | | Working Load @ Percent Tension | | | | | | | | Weight | |
|--------------------|---------------|--------------|--------------------------------|-----------|-------------------------------|-----|--------------------------------|----------|----------|-----------|---------|---------|---------|----------|--------|-------|
| Material and Color | Cross Section | | | | | | 4% (lbs) | 6% (lbs) | 8% (lbs) | 10% (lbs) | 4% (kg) | 6% (kg) | 8% (kg) | 10% (kg) | lbs/ft | kg/m |
| Eagle Orange 85 | D/32 Ribbed | 1032062 | 1-5/16 × 3/4 | 33.5 × 19 | 6 | 152 | 22.9 | 101.8 | 38.8 | 172.5 | 54.4 | 242 | 68.9 | 306.7 | 0.379 | 0.564 |
| REINFORCED | | Part Number* | Dimensions w × h† (in) (mm) | | Minimum Pulley Ø (in) (mm) | | Working Load @ Percent Tension | | | | | | | | Weight | |
| Material and Color | Cross Section | | | | | | 1% (lbs) | 2% (lbs) | 3% (lbs) | 4% (lbs) | 1% (kg) | 2% (kg) | 3% (kg) | 4% (kg) | lbs/ft | kg/m |
| Eagle Hyfen 85 CXF | D | 5260550 | 1.25 × 0.85 | | 10.88 | 276 | 77.1 | 343 | 111 | 493.6 | 149.5 | 665 | 189.4 | 842.4 | 0.448 | 0.667 |
| Eagle Hyfen 85 CXR | D | 5260555 | 1.25 × 0.85 | | 10.88 | 276 | 77.1 | 343 | 111 | 493.6 | 149.5 | 665 | 189.4 | 842.4 | 0.412 | 0.612 |

Flat Belting

Flat Belting



| NON-REINFORCED | Material and Color | Cross Section | Part Number* | Dimensions w × h† (in) (mm) | Minimum Pulley Ø (in) (mm) | Working Load @ Percent Tension | | | | | | Weight | | | |
|-----------------|--------------------|---------------|--------------|-----------------------------|----------------------------|--------------------------------|--------------|--------------|---------------|--------|------|--------|------|-------|-------|
| | | | | | | 4% (lbs) (N) | 6% (lbs) (N) | 8% (lbs) (N) | 10% (lbs) (N) | lbs/ft | kg/m | | | | |
| Eagle Orange 85 | .055" × .375" | 1032121 | .055 × .375 | 0.44 | 11 | 0.6 | 2.6 | 0.9 | 3.9 | 1.1 | 5 | 1.4 | 6.1 | 0.011 | 0.016 |
| Eagle Orange 85 | .062" × .5" | 1032126 | .062 × .500 | 0.5 | 13 | 0.9 | 3.9 | 1.3 | 5.8 | 1.7 | 7.6 | 2.1 | 9.2 | 0.016 | 0.024 |
| Eagle Orange 85 | .062" × .75"‡ | 1032210 | .062 × .750 | 0.5 | 13 | 2.3 | 10.1 | 3.4 | 15.1 | 4.4 | 19.7 | 5.4 | 23.9 | 0.042 | 0.062 |
| Eagle Orange 85 | .062" × 1.5" | 1032148 | .062 × 1.50 | 0.5 | 13 | 2.6 | 11.6 | 3.9 | 17.4 | 5.1 | 22.7 | 6.2 | 27.6 | 0.048 | 0.072 |
| Eagle Orange 85 | .062" × 1.75" | 1032155 | .062 × 1.75 | 0.5 | 13 | 3 | 13.5 | 4.6 | 20.3 | 6 | 26.5 | 7.2 | 32.2 | 0.056 | 0.084 |
| Eagle Orange 85 | .062" × 2" | 1032160 | .062 × 2.00 | 0.5 | 13 | 3.5 | 15.5 | 5.2 | 23.2 | 6.8 | 30.3 | 8.3 | 36.8 | 0.064 | 0.096 |
| Eagle Orange 85 | .062" × 3" | 1032170 | .062 × 3.00 | 0.5 | 13 | 5.2 | 23.2 | 7.8 | 34.8 | 10.2 | 45.5 | 12.4 | 55.2 | 0.097 | 0.144 |
| Eagle Orange 85 | .078" × .75" | 1032136 | .075 × .750 | 0.62 | 16 | 1.6 | 7.3 | 2.4 | 10.9 | 3.2 | 14.2 | 3.9 | 17.3 | 0.03 | 0.045 |
| Eagle Orange 85 | .090" × 1" | 1032142 | .090 × 1.00 | 0.72 | 18 | 2.5 | 11.2 | 3.8 | 16.8 | 4.9 | 21.9 | 6 | 26.6 | 0.047 | 0.069 |
| Eagle Orange 85 | .090" × 1.25" | 1032146 | .090 × 1.25 | 0.72 | 18 | 3.1 | 14 | 4.7 | 21 | 6.2 | 27.4 | 7.5 | 33.3 | 0.058 | 0.087 |
| Eagle Orange 85 | .090" × 1.5" | 1032151 | .090 × 1.50 | 0.72 | 18 | 3.8 | 16.8 | 5.7 | 25.2 | 7.4 | 33 | 9 | 40 | 0.07 | 0.104 |
| Eagle Orange 85 | .090" × 2" | 1032163 | .090 × 2.00 | 0.72 | 18 | 5 | 22.4 | 7.6 | 33.6 | 9.9 | 44 | 12 | 53.4 | 0.093 | 0.139 |
| Eagle Orange 85 | .125" × .625" | 1032133 | .125 × .625 | 1 | 25 | 2.2 | 9.7 | 3.3 | 14.5 | 4.3 | 19 | 5.2 | 23 | 0.04 | 0.06 |
| Eagle Orange 85 | .125" × 1" | 1032143 | .125 × 1.00 | 1 | 25 | 3.5 | 15.5 | 5.2 | 23.3 | 6.9 | 30.5 | 8.3 | 37 | 0.065 | 0.096 |
| Eagle Orange 85 | .250" × .625" | 1032134 | .250 × .625 | 2 | 51 | 4.4 | 19.4 | 6.5 | 29 | 8.5 | 38 | 10.4 | 46.1 | 0.081 | 0.12 |

* Standard package length 100' / 30.5m

† w (width) is the widest part of the belt. h (height) is the tallest part of the belt, including the belting top surface.

‡ Belt has a .156" radius guide.

Dimensions are for reference only.

Eagle® Blue-Green Driver Pad

- Manufactured to OEM specifications
- Always a consistent profile with ideal hole alignment
- Contains 100% virgin material, allowing maximum performance
- Always in stock, ready to go to you!

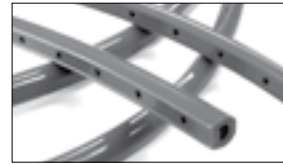

| Part Number | Package Length |
|-------------|----------------|
| 4912092 | 250' |
| 4912096 | 500' |

Eagle® Taper Edge Bands

- Long lasting, minimal stretch replacement for PVC Bands on wallboard forming lines. Significantly increased life on lines exceeding 350'/min
- Fit and forget installation reduces labor and downtime costs
- Negligible band stretch — the same perfect impression day 1 and day 100
- Temperature resistance up to 180°F (82°C)

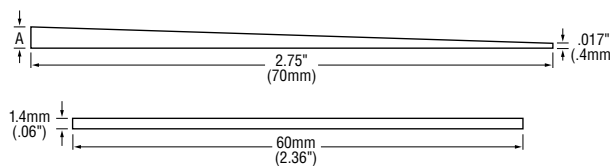

| COLOR | Part Number | | A† inches (mm) |
|-------|-------------|-------------|----------------|
| | Left Side* | Right Side* | |
| Blue | 4938280BL | 4938280BR | 0.085 (2.2) |
| Red | 4938281BL | 4938281BR | 0.075 (1.9) |
| Green | 4938282BL | 4938282BR | 0.105 (2.7) |

| COLOR | Profile | Part Number | Dimensions mm (inches) |
|---------|---------|-------------|------------------------|
| Natural | Square‡ | 4938286 | 1.4 x 60 (.06 x 2.36) |

* As belt travels toward you

† Also available in A dimensions .065" and .070"

(1.7mm and 1.8mm)

‡ Non-stock product, minimum order quantity applies

Taper Edge Band Welding Kit

- Thermal splicing for a tough, seamless, flexible joint that maintains a perfect indentation
- Full weld in 12 minutes
- No board scrap generated from joint



Taper Edge Band Return Roller

- Prevents surface scoring due to Eagle Taper Edge Band rubbing against worn return support brackets
- Easy to install mounting bracket with hand knob for quick adjustment and release
- Solid polymer plain bearing allows low-friction rotation

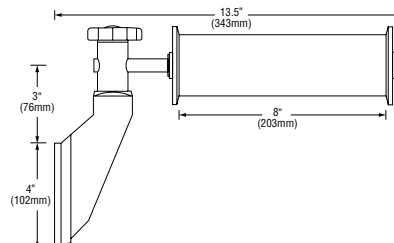

| Profile | Part Number | Voltage | Plug |
|---------|-------------|---------|------|
| Blue | 5700301 | 115v | US |
| Red | 5700304 | 115v | US |
| Green | 5700305 | 115v | US |
| Blue | 5700306 | 240v | UK |
| Red | 5700307 | 240v | UK |
| Green | 5700308 | 240v | UK |
| Square | 5700309 | 240v | UK |

Kit includes: Platen Assembly, Controller, Cutting Shears, Finger Splice Template, Instructional Disc

| | Part Number |
|-----------------------------|-------------|
| Bracket and Roller Assembly | DA0041 |
| Roller | FX0395 |

Roller dimensions:

2.375" diameter x 8" width

(60.3mm diameter x 203.2mm width)

Eagle® Welding Kits

CONVEYING – WELDING KITS

| Butt Welding Kit & Components - 120 V | Part Numbers |
|--|--------------|
| Butt Welding Kit 120 V (Large Clamp) | 5700200 |
| Mini Butt Welding Kit 120 V (Mini Clamp) | 5700231 |
| Butt Welding Clamp | 5700201 |
| Mini Clamp | 5700227 |
| Hot Knife 120 V with holder and 2" blade | 5700228 |
| Double Iron Hot Knife 120 V with holder and 3" blade | 5700220 |
| Hot Knife Holder | 5700202 |
| Hot Knife Blade – 2" | 5700233 |
| Hot Knife Blade – 3" (Use with 5700220) | 5700218 |
| Cutting Shears | 5700153 |
| Flash Cutter | 1448000 |
| Clamping Plate (2 pcs) | 5700208 |
| Flat/V belt adapter Plate (2 pcs) | 5700209 |
| Black Knurled Knob (5 pcs) | 5700212 |
| Case | 5700203 |

| Butt Welding Kit & Components – 240 V | Part Numbers |
|--|-----------------|
| Butt Welding Kit 240 V (Large Clamp) | L04FULLWELD240V |
| Mini Butt Welding Kit 240 V (Mini Clamp) | L04MINIWELD240V |
| Butt Welder Clamp | 5700201 |
| Mini Clamp | 5700227 |
| Hot Knife 240 V | L04HKNIFE240 |
| Cutting Shears | L04SHEARS |
| Flash Cutter | L04FCUTTER |
| Hot Knife Blade – 2" | L04S |
| Case (Large Clamp) | L04CASEBKST |
| Case (Mini Clamp) | L04CASEBLM |

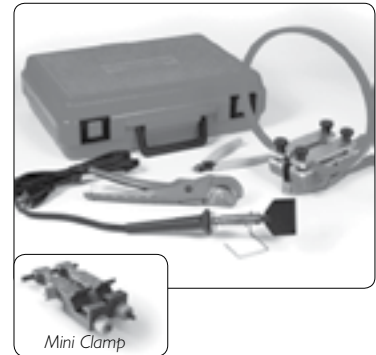

Mini Clamp

Kit Includes: Hot Knife, Large Clamp or Mini Clamp, Flash Cutters, Cutting Shears, Carrying Case

| Eagle Freestyle® Cordless Welding | Part Numbers |
|-----------------------------------|--------------|
| Freestyle Welding Kit | 5700539 |
| Freestyle Welder | 5700537 |
| Freestyle Welder Blade Assembly | 5700366 |
| Freestyle Welder End Cap | 5700367 |
| Blade Replacement Tape 10/pk | 5700542 |
| Pack of 2 D cell NiMH batteries | 5700541 |
| Cutting Shears | 5700153 |
| Flash Cutter | 1448000 |



Kit includes: Welder, Flat Plate Adapters, Professional Battery Charger, (4) D Cell NiMH Batteries, Blade Release Tape, Cutting Shears, Flash Cutters, Tool Bag

| Overlap Welding Kit & Components | Part Numbers |
|--|--------------|
| Overlap Welding Kit 120V | 5700160K |
| Overlap Welding Kit 240V | 5700161K |
| Flash Cutter | 5700152 |
| Case | 5700164 |
| Temperature Controller w/Control Box 120 V | 5700300 |
| Temperature Controller w/Control Box 240 V | 5700310 |
| Heating Tip (Z Block) | 5700325 |
| Thumb Nuts | 5700330 |
| Hold Down Pin | 5700340 |
| Thermocouple Wire | 5700350 |
| Thermocouple Connector | 5700355 |
| Heating Element, Power Cord and Plug 120 V | 5700360 |
| Heating Element, Power Cord and Plug 240 V | 5700361 |
| Plug Adapter – UK to EU | 5700351 |
| Spring | 5700380 |
| Heating Assembly Knob | 5700390 |
| 1/4" and 5/16" Die Set | 5700400 |
| 3/8" and 1/2" Die Set | 5700410 |
| 9/16", 5/8" and 16mm Die Set | 5700420 |
| 3/4" and 19mm Die | 5700430 |
| 5mm Die | 5700600 |
| 6mm Die | 5700601 |

| Overlap Welding Kit & Components | Part Numbers |
|----------------------------------|--------------|
| 7mm Die | 5700602 |
| 8mm Die | 5700603 |
| 9mm Die | 5700604 |
| 10mm Die | 5700605 |
| 12mm Die | 5700606 |
| 18mm Die | 5700608 |
| 20mm Die | 5700620 |
| Z/10 Die Set | 5700610 |
| A Hyfen Die Set | 5700440 |
| A/13 Die Set | 5700611 |
| A Ridge-Top Die Set | 5700470 |
| B Hyfen Die Set | 5700453 |
| B/17 Die Set | 5700612 |
| B Ridge-Top Die Set | 5700490 |
| C Hyfen Die Set | 5700457 |
| C/22 Die Set | 5700613 |
| D Hyfen Die Set | 5700460 |
| A Die Set for Hyfen CFX and CXR | 5700480 |
| B Die Set for Hyfen CFX and CXR | 5700472 |
| C Die Set for Hyfen CFX and CXR | 5700476 |
| D Die Set for Hyfen CFX and CXR | 5700474 |

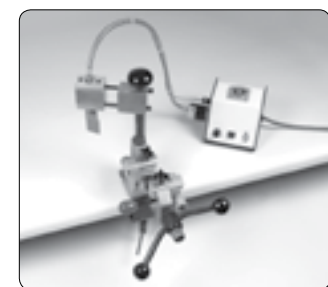

Kit Includes: Welder, Control Box, Set of Dies, Flash Cutters, Cutting Shears, Carrying Case

Trackstar® Flat Belt Guides

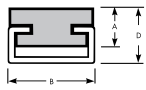

| | Part Numbers | | | | Channel Type | A | B | D |
|----------------------------------|--------------------|-------------------------|------------------|-----------|--------------|------|------|------|
| | Galvanized Channel | Stainless Steel Channel | Aluminum Channel | UHMW Only | | | | |
| Flat Guide with Mounting Channel | GR2001-3G | GR2001-3S | GR2001-3A | GR2001 | C3 | 0.39 | 0.79 | 0.60 |
| | GR2002-5G | GR2002-5S | - | GR2002 | C5 | 0.39 | 1.10 | 0.64 |
| | GR2003-9G | GR2003-9S | - | GR2003 | C9 | 0.59 | 1.50 | 0.96 |

Trackstar Guides are stocked in North America and supplied in 120" standard lengths. Subject to a minimum order quantity. Dimensions are in inches and are for reference only.

Trackstar Mounting Channels

Installation is simple with standard 120" C channels in galvanized steel, 304 stainless steel, or anodized aluminum (C3 only). Either tack weld or bolt into place with optional mounting holes.

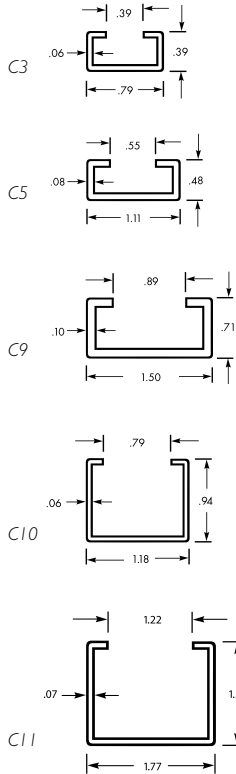

| | Part Numbers | Material | Mounting Holes | Centers |
|----------------------|--------------|----------------------|----------------|---------|
| C3 Mounting Channel | MC 0500 | Anodized Aluminum | None | - |
| | MC 1000 | Galvanized Steel | None | - |
| | MC 1001 | Galvanized Steel | .20 Diameter | 12 inch |
| | MC 1500 | #304 Stainless Steel | None | - |
| | MC 1501 | #304 Stainless Steel | .20 Diameter | 12 inch |
| C5 Mounting Channel | MC 2000 | Galvanized Steel | None | - |
| | MC 2001 | Galvanized Steel | .20 Diameter | 12 inch |
| | MC 2500 | #304 Stainless Steel | None | - |
| | MC 2501 | #304 Stainless Steel | .20 Diameter | 12 inch |
| C9 Mounting Channel | MC 3000 | Galvanized Steel | None | - |
| | MC 3500 | #304 Stainless Steel | None | - |
| C10 Mounting Channel | MC 4500 | #304 Stainless Steel | None | - |
| C11 Mounting Channel | MC 5000 | Galvanized Steel | None | - |
| | MC 5500 | #304 Stainless Steel | None | - |

Trackstar Channels are stocked in North America and supplied in 120" standard lengths. Subject to a minimum order quantity. Dimensions are in inches and are for reference only.

Trackstar Guide Rails

The "C" channel design features a two-piece construction for quick and easy replacement of UHMW inserts. "C" channel guide rails are available in Black or FDA/USDA approved White.

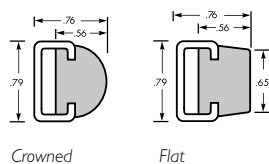

| | Profile/Color | Part Numbers | | | |
|---------------|---------------|--------------------|-------------------------|------------------|-----------|
| | | Galvanized Channel | Stainless Steel Channel | Aluminum Channel | UHMW Only |
| C3 Guide Rail | Crowned/Black | GR1000-3G120.00 | GR1000-3S120.00 | GR1000-3A120.00 | GR1000 |
| | Crowned/White | GR1001-3G120.00 | GR1001-3S120.00 | GR1001-3A120.00 | GR1001 |
| | Flat/Black | GR1100-3G120.00 | GR1100-3S120.00 | GR1100-3A120.00 | GR1100 |
| | Flat/White | GR1101-3G120.00 | GR1101-3S120.00 | GR1101-3A120.00 | GR1101 |

Trackstar Guides are stocked in North America and supplied in 120" standard lengths. Subject to a minimum order quantity. Dimensions are in inches and are for reference only.

Trackstar® Single Chain Guide with Mounting Channel

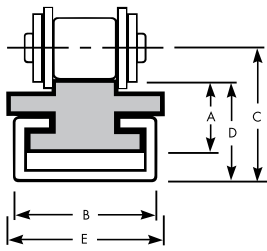

| ANSI Chain | Part Number | | | | Channel Type | A | B | C | D | E |
|------------|-------------|-----------------|-----------|-----------|--------------|------|------|------|------|------|
| | Galvanized | Stainless Steel | Aluminum | UHMW Only | | | | | | |
| 25-1 | GC1025-3G | GC1025-3S | GC1025-3A | GC1025 | C3 | 0.59 | 0.79 | 0.86 | 0.80 | 0.79 |
| 35-1 | GC1035-3G | GC1035-3S | GC1035-3A | GC1035 | C3 | 0.59 | 0.79 | 0.90 | 0.80 | 0.79 |
| 40-1 | GC1040-3G | GC1040-3S | GC1040-3A | GC1040 | C3 | 0.59 | 0.79 | 0.95 | 0.80 | 0.79 |
| 50-1 | GC1050-3G | GC1050-3S | GC1050-3A | GC1050 | C3 | 0.59 | 0.79 | 1.00 | 0.80 | 0.79 |
| 60-1 | GC1060-5G | GC1060-5S | - | GC1060 | C5 | 0.59 | 1.10 | 1.06 | 0.83 | 1.10 |
| 80-1 | GC1080-5G | GC1080-5S | - | GC1080 | C5 | 0.71 | 1.10 | 1.26 | 0.95 | 1.34 |
| 81X | GC1081-5G | GC1081-5S | - | GC1081 | C5 | 1.25 | 1.10 | 1.95 | 1.50 | 1.75 |
| 100-1 | GC1100-9G | GC1100-9S | - | GC1100 | C9 | 0.79 | 1.50 | 1.54 | 1.16 | 1.75 |
| 120-1 | GC1120-9G | GC1120-9S | - | GC1120 | C9 | 0.79 | 1.50 | 1.60 | 1.16 | 2.12 |

Trackstar Single Chain Guide

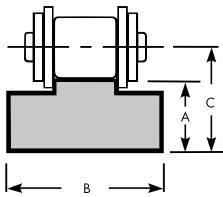

| ANSI Chain | Part Number | A | B | C |
|------------|-------------|------|------|------|
| 25-1 | NC1025 | 0.59 | 0.79 | 0.66 |
| 35-1 | NC1035 | 0.59 | 0.79 | 0.69 |
| 40-1 | NC1040 | 0.59 | 0.79 | 0.75 |
| 50-1 | NC1050 | 0.59 | 0.79 | 0.79 |
| 60-1 | NC1060 | 0.59 | 1.10 | 0.82 |
| 80-1 | NC1080 | 0.71 | 1.34 | 1.02 |
| 81X | NC1081 | 1.00 | 1.75 | 1.45 |
| 100-1 | NC1100 | 1.00 | 1.61 | 1.38 |
| 120-1 | NC1120 | 1.25 | 2.01 | 1.69 |
| 140-1 | NC1140 | 1.50 | 2.17 | 2.00 |
| 160-1 | NC1160 | 1.50 | 2.61 | 2.06 |
| 180-1 | NC1180 | 1.50 | 2.88 | 2.20 |

Trackstar Double Chain Guide with Mounting Channel

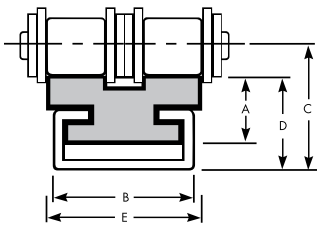

| ANSI Chain | Part Number | | | | Channel Type | A | B | C | D | E |
|------------|-------------|-----------------|-----------|-----------|--------------|------|------|------|------|-------|
| | Galvanized | Stainless Steel | Aluminum | UHMW Only | | | | | | |
| 25-2 | GC2025-3G | GC2025-3S | GC2025-3A | GC2025 | C3 | 0.44 | 0.79 | 0.72 | 0.65 | 0.79 |
| 35-2 | GC2035-3G | GC2035-3S | GC2035-3A | GC2035 | C3 | 0.59 | 0.79 | 0.89 | 0.80 | 0.57* |
| 40-2 | GC2040-3G | GC2040-3S | GC2040-3A | GC2040 | C3 | 0.59 | 0.79 | 0.95 | 0.80 | 0.85 |
| 50-2 | GC2050-5G | GC2050-5S | - | GC2050 | C5 | 0.59 | 1.10 | 1.03 | 0.84 | 1.06 |
| 60-2 | GC2060-5G | GC2060-5S | - | GC2060 | C5 | 0.59 | 1.10 | 1.06 | 0.84 | 1.34 |
| 80-2 | GC2080-9G | GC2080-9S | - | GC2080 | C9 | 0.79 | 1.50 | 1.47 | 1.16 | 1.75 |
| 100-2 | GC2100-9G | GC2100-9S | - | GC2100 | C9 | 0.79 | 1.50 | 1.54 | 1.16 | 2.12 |

Trackstar Double Chain Guide

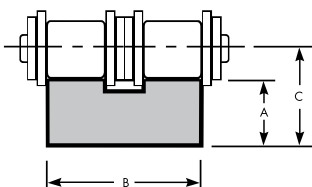

| ANSI Chain | Part Number | A | B | C |
|------------|-------------|------|------|------|
| 25-2 | NC2025 | 0.59 | 0.78 | 0.66 |
| 35-2 | NC2035 | 0.59 | 0.78 | 0.69 |
| 40-2 | NC2040 | 0.85 | 0.85 | 1.00 |
| 50-2 | NC2050 | 1.07 | 1.07 | 1.27 |
| 60-2 | NC2060 | 1.34 | 1.34 | 1.57 |
| 80-2 | NC2080 | 1.75 | 1.75 | 2.06 |

Trackstar Single Chain Guide with Mounting Channel

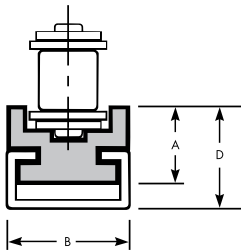

| ANSI Chain | Part Number | | | | Channel Type | A | B | D |
|------------|-------------|-----------------|-----------|-----------|--------------|------|------|------|
| | Galvanized | Stainless Steel | Aluminum | UHMW Only | | | | |
| 25-1 | GC3525-3G | GC3525-3S | GC3525-3A | GC3525 | C3 | 0.59 | 0.79 | 0.80 |
| 35-1 | GC3535-3G | GC3535-3S | GC3535-3A | GC3535 | C3 | 0.59 | 0.79 | 0.80 |
| 40-1 | GC3540-3G | GC3540-3S | GC3540-3A | GC3540 | C3 | 0.59 | 0.79 | 0.80 |
| 50-1 | GC3550-5G | GC3550-5S | - | GC3550 | C5 | 0.71 | 1.10 | 0.96 |
| 60-1 | GC3560-5G | GC3560-5S | - | GC3560 | C5 | 0.71 | 1.10 | 0.96 |
| 80-1 | GC3580-9G | GC3580-9S | - | GC3580 | C9 | 0.79 | 1.50 | 1.16 |

Trackstar Single Chain Guide

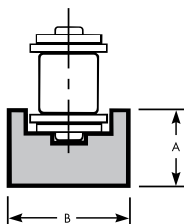

| ANSI Chain | Part Number | A | B |
|------------|-------------|------|------|
| 25-1 | NC3525 | 0.59 | 0.78 |
| 35-1 | NC3535 | 0.59 | 0.78 |
| 40-1 | NC3540 | 0.59 | 0.78 |
| 50-1 | NC3550 | 0.71 | 1.10 |
| 60-1 | NC3560 | 0.71 | 1.10 |
| 80-1 | NC3580 | 0.79 | 1.50 |

Trackstar Guides are stocked in North America and supplied in 120" standard lengths. Subject to a minimum order quantity. Dimensions are in inches and are for reference only.

Trackstar® Single Chain Guide with Mounting Channel

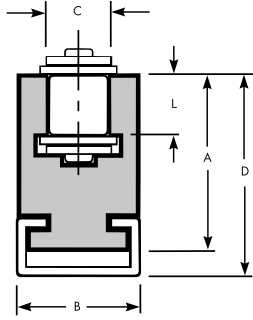

| ANSI Chain | Part Number | | | | Channel Type | A | B | C | D | L |
|------------|-------------|-----------------|-----------|-----------|--------------|------|------|------|------|------|
| | Galvanized | Stainless Steel | Aluminum | UHMW Only | | | | | | |
| 25-1 | GC3625-3G | GC3625-3S | GC3625-3A | GC3625 | C3 | 0.80 | 0.79 | 0.15 | 1.01 | 0.11 |
| 35-1 | GC3635-3G | GC3635-3S | GC3635-3A | GC3635 | C3 | 0.80 | 0.79 | 0.22 | 1.01 | 0.17 |
| 40-1 | GC3640-5G | GC3640-5S | - | GC3640 | C5 | 1.01 | 1.10 | 0.33 | 1.25 | 0.29 |
| 50-1 | GC3650-9G | GC3650-9S | - | GC3650 | C9 | 1.24 | 1.50 | 0.42 | 1.61 | 0.35 |
| 60-1 | GC3660-9G | GC3660-9S | - | GC3660 | C9 | 1.66 | 1.50 | 0.50 | 2.03 | 0.47 |
| 80-1 | GC3680-9G | GC3680-9S | - | GC3680 | C9 | 2.26 | 1.50 | 0.65 | 2.63 | 0.60 |

Trackstar Single Chain Guide

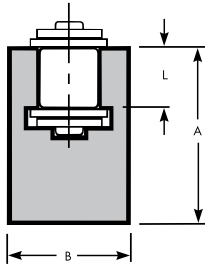

| ANSI Chain | Part Number | A | B | L |
|------------|-------------|------|------|------|
| 25-1 | NC3625 | 0.88 | 0.79 | 0.11 |
| 35-1 | NC3635 | 0.88 | 0.79 | 0.17 |
| 40-1 | NC3640 | 1.05 | 1.10 | 0.29 |
| 50-1 | NC3650 | 1.43 | 1.50 | 0.35 |
| 60-1 | NC3660 | 1.85 | 1.50 | 0.47 |

Trackstar Single Chain Guide with Mounting Channel

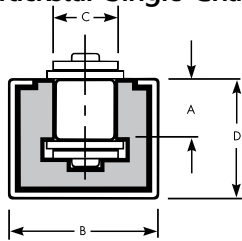

| ANSI Chain | Part Number | | | Channel Type | A | B | C | D |
|------------|-------------|-----------------|-----------|--------------|------|------|------|------|
| | Galvanized | Stainless Steel | UHMW Only | | | | | |
| 25-1 | GS1025-9G | GS1025-9S | GS1025 | C9 | 0.11 | 1.50 | 0.15 | 0.71 |
| 35-1 | GS1035-0G | GS1035-0S | GS1035 | C10 | 0.17 | 1.19 | 0.22 | 0.94 |
| 40-1 | GS1040-0G | GS1040-0S | GS1040 | C10 | 0.29 | 1.19 | 0.33 | 0.94 |
| 50-1 | GS1050-0G | GS1050-0S | GS1050 | C10 | 0.35 | 1.19 | 0.42 | 0.94 |
| 60-1 | GS1060-0G | GS1060-0S | GS1060 | C10 | 0.47 | 1.19 | 0.49 | 1.05 |
| 80-1 | GS1080-1G | GS1080-1S | GS1080 | C11 | 0.60 | 1.77 | 0.65 | 1.58 |
| 100-1 | GS1100-1G | GS1100-1S | GS1100 | C11 | 0.73 | 1.77 | 0.78 | 1.58 |

Trackstar Single Chain Guide with Mounting Channel

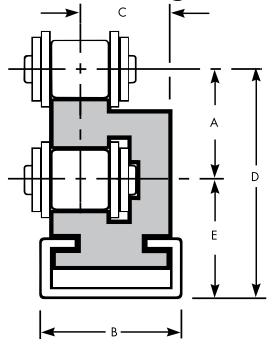

| ANSI Chain | Part Number | | | | Channel Type | A | B | C | D | E |
|------------|-------------|-----------------|-----------|-----------|--------------|------|------|------|------|------|
| | Galvanized | Stainless Steel | Aluminum | UHMW Only | | | | | | |
| 35-1 | GT1035-3G | GT1035-3S | GT1035-3A | GT1035 | C3 | 0.67 | 0.79 | 0.71 | 1.24 | 0.57 |
| 40-1 | GT1040-3G | GT1040-3S | GT1040-3A | GT1040 | C3 | 0.59 | 0.79 | 0.65 | 1.16 | 0.57 |
| 50-1 | GT1050-3G | GT1050-3S | GT1050-3A | GT1050 | C3 | 0.77 | 0.79 | 0.62 | 1.46 | 0.69 |
| 60-1 | GT1060-5G | GT1060-5S | - | GT1060 | C5 | 0.89 | 1.11 | 0.87 | 1.60 | 0.70 |

Chain Breakers



| Part Number | Description |
|-------------|--------------------------------|
| 5810100 | #1 Chain Breaker 25-60 Chain |
| 5810200 | #2 Chain Breaker 60-100 Chain |
| 5810300 | #3 Chain Breaker 100-160 Chain |

Chain Pullers



| Part Number | Description |
|-------------|---------------------------------|
| 5800350 | #35 Chain Puller 35 - 60 Chain |
| 5800500 | #50 Chain Puller 40 - 80 Chain |
| 5800800 | #80 Chain Puller 80 - 240 Chain |

Trackstar Guides are stocked in North America and supplied in 120" standard lengths. Subject to a minimum order quantity. Dimensions are in inches and are for reference only.

Double Pitch Chain Guides

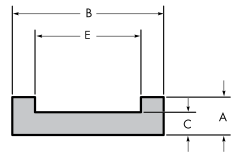

Style A

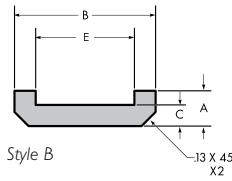

Style B

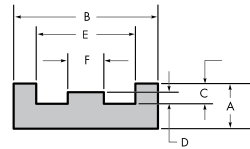

Style C

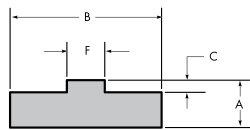

Style D

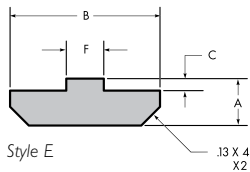

Style E

| Part Number | Chain Number | Dimensions (inches) | | | | | |
|----------------|--------------|---------------------|------|------|------|------|------|
| | | A | B | C | D | E | F |
| STYLE A | | | | | | | |
| DPA2040 | 2040 | 0.31 | 1.25 | 0.19 | - | 0.88 | - |
| DPA2050 | 2050 | 0.38 | 1.25 | 0.22 | - | 1.00 | - |
| DPA2060 | 2060 | 0.38 | 1.50 | 0.19 | - | 1.25 | - |
| DPA2080 | 2080 | 0.50 | 2.00 | 0.25 | - | 1.56 | - |
| DPA2100 | 2100 | 0.63 | 2.25 | 0.31 | - | 1.88 | - |
| DPA2120 | 2120 | 0.63 | 2.75 | 0.25 | - | 2.25 | - |
| DPA2081 | 81X | 1.00 | 3.00 | 0.38 | - | 2.50 | - |
| STYLE B | | | | | | | |
| DPB2040 | 2040 | 0.31 | 1.25 | 0.19 | - | 0.88 | - |
| DPB2050 | 2050 | 0.38 | 1.25 | 0.22 | - | 1.00 | - |
| DPB2060 | 2060 | 0.38 | 1.50 | 0.19 | - | 1.25 | - |
| DPB2080 | 2080 | 0.50 | 2.00 | 0.25 | - | 1.56 | - |
| DPB2100 | 2100 | 0.63 | 2.25 | 0.31 | - | 1.88 | - |
| DPB2120 | 2120 | 0.63 | 2.75 | 0.25 | - | 2.25 | - |
| STYLE C | | | | | | | |
| DPC2040 | 2040 | 0.31 | 1.00 | 0.14 | 0.08 | 0.69 | 0.25 |
| DPC2050 | 2050 | 0.38 | 1.25 | 0.19 | 0.10 | 0.81 | 0.31 |
| DPC2060 | 2060 | 0.50 | 1.50 | 0.21 | 0.12 | 1.13 | 0.44 |
| DPC2080 | 2080 | 0.50 | 2.00 | 0.25 | 0.13 | 1.44 | 0.56 |
| STYLE D | | | | | | | |
| DPD2040 | 2040 | 0.31 | 1.00 | 0.08 | - | - | 0.25 |
| DPD2050 | 2050 | 0.31 | 1.25 | 0.10 | - | - | 0.31 |
| DPD2060 | 2060 | 0.31 | 1.25 | 0.12 | - | - | 0.44 |
| DPD2080 | 2080 | 0.38 | 1.50 | 0.13 | - | - | 0.56 |
| DPD2100 | 2100 | 0.50 | 2.00 | 0.21 | - | - | 0.69 |
| DPD2120 | 2120 | 0.50 | 2.25 | 0.26 | - | - | 0.94 |
| STYLE E | | | | | | | |
| DPE2040 | 2040 | 0.31 | 1.00 | 0.08 | - | - | 0.25 |
| DPE2050 | 2050 | 0.31 | 1.25 | 0.10 | - | - | 0.31 |
| DPE2060 | 2060 | 0.31 | 1.25 | 0.12 | - | - | 0.44 |
| DPE2080 | 2080 | 0.38 | 1.50 | 0.13 | - | - | 0.56 |
| DPE2100 | 2100 | 0.50 | 2.00 | 0.21 | - | - | 0.69 |
| DPE2120 | 2120 | 0.50 | 2.25 | 0.26 | - | - | 0.94 |

T-Max® Tensioner/Sprocket Assemblies

| Assembly Part Number | Component | Component Part Number | Rotation (Degrees) | Force (lbs) |
|----------------------|--------------------|-----------------------|--------------------|-------------|
| #35 Chain | | | | |
| FS0142 | Tensioner Sprocket | RT1001 CS3502 | 15 | 16 |
| | | | 30 | 23 |
| | | | 45 | 30 |
| FS0658 | Tensioner Sprocket | RT1601-L CS3502 | 15 | 10 |
| | | | 30 | 13 |
| | | | 45 | 16 |
| #40 Chain | | | | |
| FS0651 | Tensioner Sprocket | RT1001 CS4002 | 15 | 16 |
| | | | 30 | 23 |
| | | | 45 | 30 |
| FS0652 | Tensioner Sprocket | RT1601 CS4002 | 15 | 20 |
| | | | 25 | 23 |
| | | | 35 | 26 |
| FS0644 | Tensioner Sprocket | RT1601-L CS4002 | 15 | 10 |
| | | | 30 | 13 |
| | | | 45 | 16 |
| FS0557 | Tensioner Sprocket | RT3001 CS4002 | 0 - 70 | 0 - 42 |
| #50 Chain | | | | |
| FS0653 | Tensioner Sprocket | RT1001 CS5002 | 15 | 16 |
| | | | 30 | 23 |
| | | | 45 | 30 |
| FS0654 | Tensioner Sprocket | RT1601 CS5002 | 15 | 20 |
| | | | 25 | 23 |
| | | | 35 | 26 |
| FS0659 | Tensioner Sprocket | RT1601-L CS5002 | 15 | 10 |
| | | | 30 | 13 |
| | | | 45 | 16 |
| FS0567 | Tensioner Sprocket | RT3001 CS5002 | 0 - 70 | 0 - 42 |
| #60 Chain | | | | |
| FS0655 | Tensioner Sprocket | RT1001 CS6002 | 15 | 16 |
| | | | 30 | 23 |
| | | | 45 | 30 |
| FS0656 | Tensioner Sprocket | RT1601 CS6002 | 15 | 20 |
| | | | 25 | 23 |
| | | | 35 | 26 |
| FS0568 | Tensioner Sprocket | RT3001 CS6002 | 0 - 70 | 0 - 42 |
| #80 Chain | | | | |
| FS0657 | Tensioner Sprocket | RT1001 CS8002 | 15 | 16 |
| | | | 30 | 23 |
| | | | 45 | 30 |

Fenner Drives has several tensioner/sprocket assemblies not shown here. Contact us for availability.



Trackstar Guides are stocked in North America and supplied in 120" standard lengths. Subject to a minimum order quantity. Dimensions are in inches and are for reference only.

T-Max® Chain Tensioners CT Series: CT1100, CT2100 & CT3100†

| Part Number | Travel | | Force ‡ | |
|-------------|--------|------|----------|-----------|
| | (in) | (mm) | (lbs) | (N) |
| 1100-L | 1.05 | 27 | 5 - 30 | 22 - 133 |
| 1100 | 1.05 | 27 | 15 - 40 | 67 - 178 |
| 2100 | 1.20 | 31 | 20 - 60 | 89 - 267 |
| 3100 | 1.50 | 38 | 45 - 100 | 200 - 445 |
| 3100-H | 1.00 | 25 | 30 - 200 | 134 - 890 |
| 3196 | 1.50 | - | 45 - 100 | - |

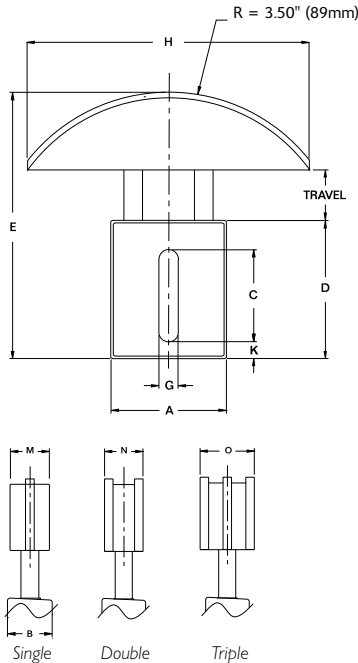

Common Dimensions

| Series | Dimensions* | | | | | | | |
|---------------|-------------|------|------|------|-----|------|-----|------|
| | A | B | C | D | E | G | H | K |
| INCH | | | | | | | | |
| CT1100 | 2.31 | 0.98 | 1.82 | 2.91 | 5.6 | 0.41 | 5.5 | 0.46 |
| CT2100 | 2.95 | 1.18 | 2.27 | 3.52 | 6.4 | 0.49 | 5.5 | 0.45 |
| CT3100 | 3.54 | 1.38 | 2.91 | 4.25 | 7.5 | 0.53 | 5.5 | 0.49 |
| METRIC | | | | | | | | |
| CT1100 | 59 | 25 | 46 | 74 | 142 | 10 | 140 | 11 |
| CT2100 | 75 | 30 | 58 | 89 | 163 | 12 | 140 | 11 |
| CT3100 | 90 | 35 | 74 | 108 | 191 | 13 | 140 | 12 |

| Part Number | Single Chain | | Double Chain | | Triple Chain | | | |
|---------------|--------------|------|--------------|-------|--------------|-------------|-------|------|
| | Chain | M* | Part Number | Chain | N* | Part Number | Chain | O* |
| INCH | | | | | | | | |
| CT1101-L | #35 | 0.79 | CT1103-L | #35 | 0.79 | CT1105-L | #35 | 0.98 |
| CT1101 | #35 | 0.79 | CT1103 | #35 | 0.79 | CT1105 | #35 | 0.98 |
| CT1102 | #40 | 0.79 | CT1104 | #40 | 0.79 | CT1106 | #40 | 1.37 |
| CT2101 | #50 | 0.87 | CT2103 | #50 | 0.98 | CT2105 | #50 | 1.75 |
| CT2102 | #60 | 0.87 | CT2104 | #60 | 1.37 | | | |
| CT3101 | #80 | 0.98 | CT3103 | #80 | 1.75 | | | |
| CT3102 | #100 | 0.98 | | | | | | |
| CT3102-H | #100 | 0.98 | | | | | | |
| CT3196 | #81X | 2.15 | | | | | | |
| METRIC | | | | | | | | |
| CT1111-L | 06B | 20 | CT1113-L | 06B | 20 | | | |
| CT1111 | 06B | 20 | CT1113 | 06B | 20 | | | |
| CT1112 | 08B | 20 | CT1114 | 08B | 20 | | | |
| CT2111 | 10B | 22 | CT2112 | 10B | 25 | | | |
| CT2109 | 12B | 22 | CT2110 | 12B | 35 | | | |
| CT3111 | 16B | 25 | CT3113 | 16B | 44 | | | |
| CT3112 | 20B | 25 | | | | | | |
| CT3112-H | 20B | 25 | | | | | | |

CT Series: CT1200, CT2200 & CT3200†

| Part Number | Travel | | Force ‡ | |
|-------------|--------|------|----------|-----------|
| | (in) | (mm) | (lbs) | (N) |
| 1200-L | 1.05 | 27 | 5 - 30 | 22 - 133 |
| 1200 | 1.05 | 27 | 15 - 40 | 67 - 178 |
| 2200 | 1.20 | 31 | 20 - 60 | 89 - 267 |
| 3200 | 1.50 | 38 | 45 - 100 | 200 - 445 |
| 3200-H | 1.00 | 25 | 30 - 200 | 134 - 890 |

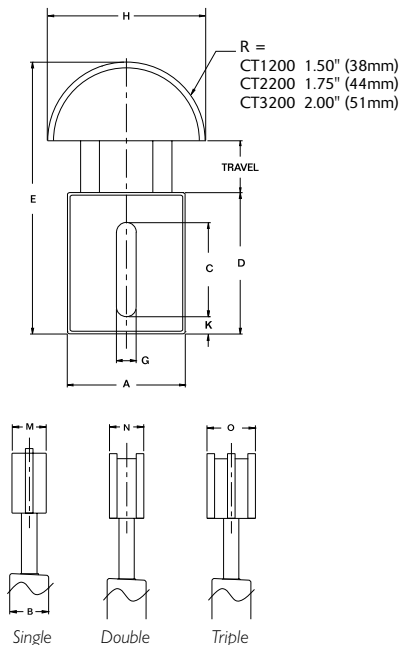

Common Dimensions

| Series | Dimensions* | | | | | | | |
|---------------|-------------|----|------|------|------|------|-----|------|
| | A | B | C | D | E | G | H | K |
| INCH | | | | | | | | |
| CT1200 | 2.31 | 1 | 1.82 | 2.91 | 5.47 | 0.41 | 3 | 0.46 |
| CT2200 | 2.95 | 1 | 2.27 | 3.52 | 6.47 | 0.49 | 3.5 | 0.45 |
| CT3200 | 3.54 | 1 | 2.91 | 4.25 | 7.8 | 0.53 | 4 | 0.49 |
| METRIC | | | | | | | | |
| CT1200 | 59 | 25 | 46 | 74 | 139 | 10 | 76 | 11 |
| CT2200 | 75 | 30 | 58 | 89 | 164 | 12 | 89 | 11 |
| CT3200 | 90 | 35 | 74 | 108 | 198 | 13 | 102 | 12 |

| Part Number | Single Chain | | Double Chain | | Triple Chain | | | |
|---------------|--------------|------|--------------|-------|--------------|-------------|-------|------|
| | Chain | M* | Part Number | Chain | N* | Part Number | Chain | O* |
| INCH | | | | | | | | |
| CT1201-L | #35 | 1 | CT1203-L | #35 | 0.79 | CT1205-L | #35 | 0.98 |
| CT1201 | #35 | 1 | CT1203 | #35 | 0.79 | CT1205 | #35 | 0.98 |
| CT1202 | #40 | 1 | CT1204 | #40 | 0.79 | CT1206 | #40 | 1.37 |
| CT2201 | #50 | 1 | CT2203 | #50 | 0.98 | CT2205 | #50 | 1.75 |
| CT2202 | #60 | 1 | CT2204 | #60 | 1.37 | | | |
| CT3201 | #80 | 0.98 | CT3203 | #80 | 1.75 | | | |
| CT3202 | #100 | 0.98 | | | | | | |
| CT3202-H | #100 | 0.98 | | | | | | |
| METRIC | | | | | | | | |
| CT1211-L | 06B | 20 | CT1213-L | 06B | 20 | | | |
| CT1211 | 06B | 20 | CT1213 | 06B | 20 | | | |
| CT1212 | 08B | 20 | CT1214 | 08B | 20 | | | |
| CT2208 | 10B | 22 | CT2209 | 10B | 25 | | | |
| CT2206 | 12B | 22 | CT2207 | 12B | 35 | | | |
| CT3211 | 16B | 25 | CT3213 | 16B | 44 | | | |
| CT3212 | 20B | 25 | | | | | | |
| CT3212-H | 20B | 25 | | | | | | |

* Inch dimensions are in inches; metric dimensions are in millimeters.
 † These tensioners can be used on chain sizes up to ANSI #160 or BS/DIN #24B.
 Contact Fenner Drives Applications Engineering group at AE@fennerdrives.com for head dimensions.
 ‡ All forces are nominal.

Round Belting

Round belts are commonly run in pulleys with a round groove; see Figure 1a. In the absence of round groove pulleys, they can also be used in V-groove pulleys (Figure 1b). The table at right shows the dimensional data for a round belt used in a V-groove pulley.

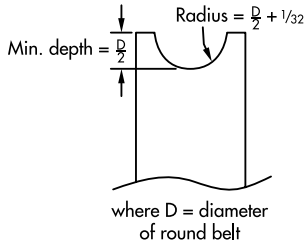

Figure 1a

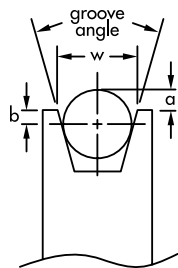

Figure 1b

| Pulley Size | Pulley Diameter (inches) | Groove Angle | Round Belt | Dimensions (inches) | | |
|-------------|--------------------------|--------------|------------|---------------------|-------|-------|
| | | | | w | a | b |
| 2L | Under 1.50" | 32° | 3/16" | .240 | .010 | .084 |
| 2L | 1.50" to 1.99" O.D. | 34° | 3/16" | .243 | .016 | .078 |
| | | | 1/4" | .243 | .153 | -.028 |
| 2L | 2.00" to 2.50" O.D. | 36° | 3/16" | .246 | .020 | .074 |
| | | | 1/4" | .246 | .151 | -.026 |
| 2L | Over 2.50" O.D. | 38° | 3/16" | .250 | .020 | .074 |
| | | | 1/4" | .250 | .146 | -.021 |
| 3L | Under 2.20" O.D. | 32° | 1/4" | .360 | -.049 | .174 |
| | | | 5/16" | .360 | .094 | .062 |
| 3L | 2.20" to 3.19" O.D. | 34° | 1/4" | .364 | -.043 | .168 |
| | | | 5/16" | .364 | .094 | .062 |
| 3L | 3.20" to 4.20" O.D. | 36° | 1/4" | .368 | -.037 | .062 |
| | | | 5/16" | .368 | .095 | .061 |
| 3L | Over 4.20" O.D. | 38° | 1/4" | .372 | -.031 | .156 |
| | | | 5/16" | .372 | .095 | .061 |
| A/13 | 2.60" to 5.40" D.D. | 34° | 5/16" | .494 | -.118 | .274 |
| | | | 3/8" | .494 | .019 | .168 |
| | | | 1/2" | .494 | .297 | -.047 |
| A/13 | Over 5.40" D.D. | 38° | 5/16" | .504 | -.097 | .253 |
| | | | 3/8" | .504 | .030 | .157 |
| | | | 1/2" | .504 | .286 | .036 |
| B/17 | 4.60" to 7.00" D.D. | 34° | 1/2" | .637 | .062 | .188 |
| | | | 9/16" | .637 | .199 | .082 |
| | | | 5/8" | .637 | .340 | -.027 |
| B/17 | Over 7.00" D.D. | 38° | 1/2" | .650 | .074 | .176 |
| | | | 9/16" | .650 | .200 | .081 |
| | | | 5/8" | .650 | .331 | -.018 |
| C/22 | 7.00" to 7.99" D.D. | 34° | 5/8" | .879 | -.056 | .369 |
| | | | 3/4" | .879 | .218 | .157 |
| C/22 | 8.00" to 12.00" D.D. | 36° | 5/8" | .887 | -.041 | .354 |
| | | | 3/4" | .887 | .222 | .153 |
| C/22 | Over 12.00" D.D. | 38° | 5/8" | .895 | -.027 | .340 |
| | | | 3/4" | .895 | .226 | .149 |

Note: above dimensions are belt fit in groove under no tension. Dimensions in inches unless otherwise indicated.

V Belting

V belts in "classical" A, B, C, D and light duty 3L cross sections are designed to fit RMA compliant pulleys as per the groove details illustrated in Figure 2.

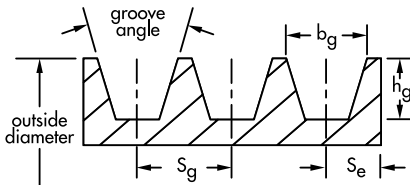

Figure 2

| Cross Section | Datum Diameter Range | Groove Angle | bg (inches) | hg min (inches) | Sg (inches) | Se (inches) |
|---------------|----------------------|--------------|--------------|-----------------|--------------|-------------|
| A/13 | Up thru 5.4" | 34° ±0.33° | .494 | .460 | .625 ± .025 | .375 +.090 |
| | Over 5.4" | 38° ±0.33° | .504 ± .005 | .504 | .750 ± .025 | -.062 |
| B/17 | Up thru 7.0" | 34° ±0.33° | .637 | .550 | .750 ± .025 | .500 +.120 |
| | Over 7.0" | 38° ±0.33° | .650 ± .006 | .650 | .750 ± .025 | -.065 |
| C/22 | Up thru 7.99" | 34° ±0.33° | .879 | .750 | 1.000 ± .025 | .688 +.160 |
| | 8.0" thru 12.0" | 36° ±0.33° | .887 ± .007 | .750 | 1.000 ± .025 | -.070 |
| | Over 12.0" | 38° ±0.33° | .895 | .750 | 1.000 ± .025 | -.070 |
| D/32 | Up thru 12.99" | 34° ±0.33° | 1.259 | 1.020 | 1.438 ± .025 | .875 +.220 |
| | 13.0" thru 17.0" | 36° ±0.33° | 1.271 ± .008 | 1.020 | 1.438 ± .025 | -.080 |
| | Over 17.0" | 38° ±0.33° | 1.283 | 1.020 | 1.438 ± .025 | -.080 |
| 3L | 2.2" thru 3.1" | 34° ±0.33° | .364 | .406 | .500 ± .025 | .313 +.062 |
| | 3.2" thru 4.2" | 36° ±0.33° | .364 ± .005 | .406 | .500 ± .025 | -.032 |
| | Over 4.2" | 38° ±0.33° | .364 ± .005 | .406 | .500 ± .025 | -.032 |

Dimensions in inches unless otherwise indicated.

Flat Belting

All flat belts have a natural tendency to move laterally. Therefore a flat or straight pulley is not recommended, as the belt would walk off the pulley. To keep the belt in the center of the pulley it must have a crown. Figure 3a illustrates a round crown and is the preferred method. A modified round crown as illustrated in Figure 3b is also acceptable. A flat pulley with guide flanges (Figure 3c) is not recommended. Even with the guide flanges the belt will move laterally and potentially could climb up onto them.

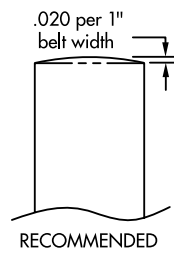

Figure 3a

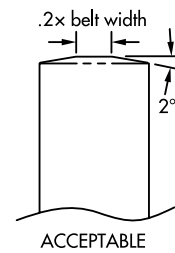

Figure 3b

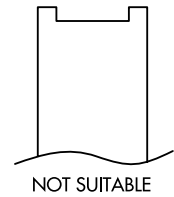

Figure 3c

Round Belting

Round belts are commonly run in pulleys with a round groove; see Figure 1 a. In the absence of round groove pulleys, they can also be used in V-groove pulleys (Figure 1 b). The table at right shows the dimensional data for a round belt used in a V-groove pulley.

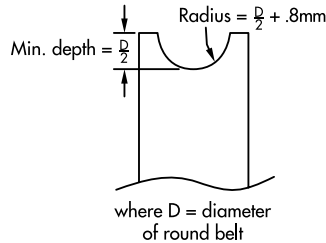

Figure 1 a

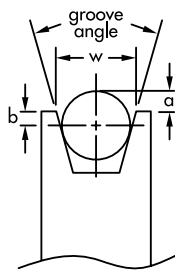

Figure 1 b

| Pulley Size | Pulley Diameter (mm) | Groove Angle | Round Belt | Dimensions (mm) | | |
|-------------|----------------------|--------------|------------|-----------------|-------|-------|
| | | | | w | a | b |
| Z/10 | Up thru 80mm | 34° | 7 | 9.7 | -0.39 | 3.89 |
| | | | 8 | 9.7 | 1.82 | 2.18 |
| | | | 9.5 | 9.7 | 5.14 | -0.39 |
| Z/10 | Over 80mm | 38° | 7 | 9.7 | 0.17 | 3.34 |
| | | | 8 | 9.7 | 2.19 | 1.81 |
| | | | 9.5 | 9.7 | 5.25 | -0.50 |
| A/13 | Up thru 118mm | 34° | 9.5 | 12.7 | 0.23 | 4.52 |
| | | | 10 | 12.7 | 1.33 | 3.67 |
| | | | 12 | 12.7 | 5.75 | 0.25 |
| A/13 | Over 118mm | 38° | 9.5 | 12.7 | 0.90 | 3.85 |
| | | | 10 | 12.7 | 1.91 | 3.09 |
| | | | 12 | 12.7 | 5.98 | 0.02 |
| B/17 | Up thru 190mm | 34° | 12 | 16.3 | -0.14 | 6.14 |
| | | | 15 | 16.3 | 6.50 | 1.00 |
| | | | 16 | 16.3 | 8.71 | -0.71 |
| B/17 | Over 190mm | 38° | 12 | 16.3 | 0.76 | 5.24 |
| | | | 15 | 16.3 | 6.87 | 0.63 |
| | | | 16 | 16.3 | 8.90 | -0.90 |
| C/22 | Up thru 315mm | 34° | 20 | 22 | 8.22 | 1.78 |
| C/22 | Over 315mm | 38° | 20 | 22 | 9.00 | 1.23 |

Note: above dimensions are belt fit in groove under no tension. Dimensions in millimeters unless otherwise indicated.

V Belting

V belts in “classical” Z/10, A/13, B/17, C/22 and D/32 cross sections are designed to fit ISO and DIN 2215 compliant pulleys as per the groove details illustrated in Figure 2.

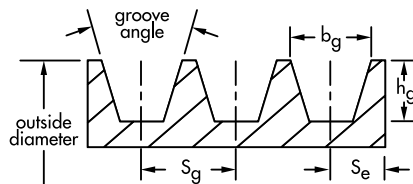

Figure 2

| Cross Section | Datum Diameter Range | Groove Angle | b _g (mm) | h _g Min (mm) | S _g (mm) | S _e (mm) |
|---------------|-----------------------------|----------------------|---------------------|-------------------------|---------------------|---------------------|
| Z/10 | Up thru 80mm Over 80mm | 34° ±1° 38° ±1° | 9.7 | 11 | 12 ±0.3 | 8 ±0.6 |
| A/13 | Up thru 118mm Over 118mm | 34° ±1° 38° ±1° | 12.7 | 14 | 15 ±0.3 | 10 ±0.6 |
| B/17 | Up thru 190mm Over 190mm | 34° ±1° 38° ±1° | 16.3 | 18 | 19 ±0.4 | 12.5 ±0.8 |
| C/22 | Up thru 315mm Over 315mm | 34° ±1° 38° ±30' | 22 | 24 | 25.5 ±0.5 | 17 ±1.0 |
| D/32 | Up thru 500mm Over 500mm | 36° ±30' 38° ±30' | 32 | 28 | 37 ±0.6 | 24 ±2.0 |

Dimensions in millimeters unless otherwise indicated.

Flat Belting

All flat belts have a natural tendency to move laterally. Therefore a flat or straight pulley is not recommended, as the belt would walk off the pulley. To keep the belt in the center of the pulley it must have a crown. Figure 3a illustrates a round crown and is the preferred method. A modified round crown as illustrated in Figure 3b is also acceptable. A flat pulley with guide flanges (Figure 3c) is not recommended. Even with the guide flanges the belt will move laterally and potentially could climb up onto them.

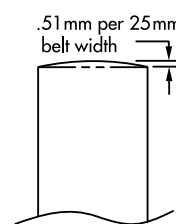

RECOMMENDED

Figure 3a

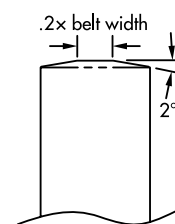

ACCEPTABLE

Figure 3b

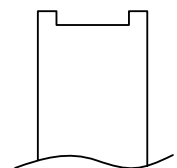

NOT SUITABLE

Figure 3c

Belt Installation Tension

All belts require a certain amount of tension to function properly in the application. The specific installation tension is determined from several factors including belt type, construction and working load. Belt details are in the Technical Data section of this catalog and working load is derived from your application.

Non-Reinforced Belting: When non-reinforced belting is stretched and released, elasticity is the property that brings the material back to its original shape. This “memory” is what gives our non-reinforced belting its self-tensioning properties. When a non-reinforced belt is first installed (stretched) the material does not return to 100% of its original length and continues to lose elasticity over its life span. This loss in elasticity is evident as tension decay. To overcome tension decay effects, a non-reinforced belt requires a relatively high install tension. Installation tensions ranging from 6% to 10% will normally be sufficient for most applications. If higher tensions are required, the application may exceed the belt’s load capacity.

Reinforced Belting: Reinforced belts contain a reinforcing tensile member which increases the belt’s modulus of elasticity. This reduces the belt’s ability to stretch and minimizes tension decay. This allows a reinforced belt to carry a greater load than a non-reinforced belt. Since an endless reinforced belt is essentially a fixed length, it cannot be stretched on like a non-reinforced belt. Consequently, reinforced belts require a mechanical take-up mechanism to apply the appropriate installation tension as well as accommodating any eventual small amount of tension decay that may occur. This mechanism should accommodate at least 4% of the belt’s length.

Belt Installation Length

In this section, we will refer to two different lengths that are defined as follows:

1. **Reference Length:** The length determined by taking a measuring tape and following the path of the belt around all of the pulleys, or through computer aided design (CAD) techniques. This length may also be obtained from the equation below. Take up mechanisms should be adjusted to the minimum position to allow for maximum adjustment of the belt prior to taking or calculating length. Note: this equation applies to two-pulley drives only.

$$L = 2C + \frac{\pi}{2}(D + d) + \frac{(D - d)^2}{4C}$$

where: L = reference length
 C = center of pulley shaft to center of pulley shaft distance
 D = pitch diameter of large pulley
 d = pitch diameter of small pulley

2. **Install Length:** The length the belt is made to prior to welding or joining.

Apply the following formulas to determine the Install Length from Reference Length:

Butt weld non-reinforced:

$$\text{Install Length} = \text{Reference Length} \div (1 + \% \text{ tension})$$

Example: Reference Length for a non-reinforced belt is 44" (1120mm), requires 8% tension and will be butt welded. Install Length is calculated on right.

| | |
|---------------------------------|------------------------------------|
| Install Length = 44" ÷ (1 + 8%) | Install Length = 1120mm ÷ (1 + 8%) |
| = 44" ÷ 1.08 | = 1120mm ÷ 1.08 |
| = 40.7" | = 1037mm |

Overlap weld reinforced: Install Length = Reference Length + 1.5" (38mm)
 Example: Reference Length for a reinforced belt is 44" (1120mm) and will be overlap welded. The overlap weld consumes 1.5" (38mm) of belt length. Install Length is calculated on right.

| | |
|-----------------------------|--------------------------------|
| Install Length = 44" + 1.5" | Install Length = 1120mm + 38mm |
| = 45.5" | = 1158mm |

Butt weld reinforced: Install Length = Reference Length
 Example: Reference Length for a reinforced belt is 44" (1120mm) and will be butt welded. The weld consumes a negligible amount of belt length, consequently, Install Length and Reference Length are the same. Install Length is calculated on right.

| | |
|----------------------|-------------------------|
| Install Length = 44" | Install Length = 1120mm |
|----------------------|-------------------------|

Link Belting: Install length = Reference Length minus (1 - 2%)
 Example: Reference Length for a link belt is 44" (1120mm). Install Length removing 2% is calculated on right.
 Remove links to get as close as possible to Install Length.

| | |
|-----------------------------------|--|
| Install Length = 44" - (44 x .02) | Install Length = 1120mm - (1120 x .02) |
| = 44" - 0.88" | = 1120mm - 22.40 |
| = 43.12" | = 1097.60mm |

Temperature

The temperature range of polyurethane belting is determined by the thermoplastic resin. Like all thermoplastic resins its physical properties change with changes in temperature. At higher temperatures the material will soften, lose strength and can elongate excessively to the point of premature failure. At lower temperatures the material will become more brittle and stiff which can result in cracking. The temperature ranges are for guidance and listed under each individual belt type in the Material Properties section.

Minimum Pulley Diameter

The most common serious mistake in designing belt drives is the selection of a pulley diameter that is too small. In most cases, non-reinforced belts can operate on smaller diameter pulleys than belts with a reinforcing tensile member. Reinforced belts require a larger pulley diameter to prevent premature flex fatigue failure of the tensile member. Listed under each individual belt type’s technical data is the recommended minimum pulley diameter. Smaller diameters can be used only if a reduction in belt service life is acceptable.

Engineering Data – Selection Procedure, Conveying

- Refer to the Technical Data chart for the belt material and cross section selected.
 - Use the following formula that meets your application requirements (Note: if belt supported by rollers use .17 for μ):
 - Horizontal Transport with Slider Bed
 $T_e = W_t \times \mu + B_{wt}$
 - Horizontal Transport with Slider Bed and Product Accumulation
 $T_e = W_t \times \mu + B_{wt} + A_{wt}$
 - Incline or Decline Transport with Slider Bed
 $T_e = \frac{W_t}{C} \times (H_t + \mu \times \sqrt{C^2 + H_t^2}) + B_{wt}$
 - Incline or Decline Transport with Slider Bed and Product Accumulation
 $T_e = \frac{W_t}{C} \times (H_t + \mu \times \sqrt{C^2 + H_t^2}) + B_{wt} + A_{wt}$
 - Determine Tight Tension (T_1).
 Flat and round belts: $T_1 = T_e \times 2$
 V belts: $T_1 = T_e \times 1.25$
 - Refer to the Technical Data chart for the material and cross section selected and compare T_1 to the Working Load at maximum % tension. If only one belt is desired, T_1 may not be greater than the Working Load at maximum % tension. If more than one belt is required, divide T_1 by the Working Load at maximum % tension to arrive at number of belts. Round up to the nearest whole number of belts.
 - Find load per belt by dividing T_1 by number of belts. From the Technical Data chart, determine the percent installed tension for the load per belt.
- To determine the required belt length, please refer to the "Belt Installation Length" section on the previous page.

Where:
 T_e = Effective Tension
 W_t = Total Weight on Conveyor
 C = Conveyor Center Distance
 B_{wt} = Belt weight/unit length $\times C$
 A_{wt} = Accumulating weight $\times \mu'$
 (where μ' is the COF between belt and product)
 H_t = Incline or decline height
 μ = COF on slider bed material from chart

Engineering Data – Selection Example

| NON-REINFORCED | Color | Part Number | Dimensions \varnothing (mm) | | Minimum Pulley \varnothing (in) | Working Load @ Percent Tension | | | | | | | | Weight | |
|------------------|-------|-------------|-------------------------------|------|-----------------------------------|--------------------------------|--------|--------|---------|-------|------|-------|------|--------|-------|
| | | | (in) | (mm) | | 4% (N) | 6% (N) | 8% (N) | 10% (N) | (lbs) | (N) | (lbs) | (N) | lbs/ft | kg/m |
| Eagle® Orange 85 | | L04OG856M | 6 | 1.89 | 48 | 1.7 | 7.7 | 2.7 | 11.8 | 3.5 | 15.8 | 4.4 | 19.4 | 0.023 | 0.034 |
| Eagle Orange 85 | | 1032008 | 1/4 | 6.3 | 51 | 1.9 | 8.6 | 3 | 13.3 | 4 | 17.7 | 4.9 | 21.9 | 0.026 | 0.038 |

| NON-REINFORCED Product | Hardness | FDA Compliant | Coefficient of Friction | | | Contact Temperature Range | |
|------------------------|----------|---------------|-------------------------|-------|------|---------------------------|------------|
| | | | Stainless Steel | Steel | UHMW | °F | °C |
| Eagle Orange 85 | 85A | Yes | 0.70 | 0.60 | 0.45 | -22 to +150 | -30 to +66 |

Example 1

- Type of belt being considered = Eagle Orange 85 in 1/4" round
 Head-to-tail center distance (C) = 10 feet
 Incline or decline = none
 Product accumulation on belt(s)? = no
 Total weight on belt(s) = 15 lbs.
 Type of belt support = UHMW slider bed
- Horizontal Transport with Slider Bed.
 Since the belt will run in UHMW slider bed the COF(μ) of .45 is used from Technical Data chart. From the chart the belt weight is .026 lbs/ft giving a total belt weight of .26 lbs (.026 \times 10').
 $T_e = 15 \text{ lbs} \times .45 + .26 = 7.01$
 - Determine Tight Tension (T_1).
 round belts $T_1 = 7.01 \times 2 = 14.02$
 - Refer to the Technical Data chart for the material and cross section selected and compare T_1 to the Working Load at 10% tension. If only one belt is desired, T_1 may not be greater than the Working Load at 10% tension. If more than one belt is required, divide T_1 by the Working Load at 10% tension to arrive at number of belts. Round up to the nearest whole number of belts.
 1/4" round rated 4.9 lbs @ 10% tension. $14.02 \div 4.9 = 2.86$ use 3 belts
 - Find load per belt by dividing T_1 by number of belts. From the Technical Data chart, determine the percent installed tension for the load per belt.
 Load/belt = $14.02 \div 3 = 4.67$ lbs
 Corresponding installed tension = 9.7%

Example 2

- Eagle Orange 85 in 6mm round
 Head-to-tail center distance (C) = 3 meters
 Incline or decline = none
 Product accumulation on belt(s)? = no
 Total weight on belt(s) = 6 kg
 Type of belt support = UHMW slider bed
- Horizontal Transport with Slider Bed.
 Since the belt will run in UHMW slider bed the COF(μ) of .45 is used from Technical Data chart. From the chart the belt weight is .034 kgs/m giving a total belt weight of .102 kg (.034 \times 3m).
 $T_e = 6 \text{ kg} \times .45 + .102 = 2.802 \text{ kg}$
 - Determine Tight Tension (T_1).
 round belts $T_1 = 2.802 \times 2 = 5.604 \text{ kg} = 54.98 \text{ Newtons} (5.604 \times 9.81)$
 - Refer to the Technical Data chart for the material and cross section selected and compare T_1 to the Working Load at 10% tension. If only one belt is desired, T_1 may not be greater than the Working Load at 10% tension. If more than one belt is required, divide T_1 by the Working Load at 10% tension to arrive at number of belts. Round up to the nearest whole number of belts.
 6mm round rated 19.4 N @ 10% tension. $54.98 \div 19.4 = 2.83$ use 3 belts
 - Find load per belt by dividing T_1 by number of belts. From the Technical Data chart, determine the percent installed tension for the load per belt.
 Load/belt = $54.98 \text{ N} \div 3 = 18.33 \text{ Newtons}$
 Corresponding installed tension = 9.6%



| NON-REINFORCED Material and Color | Hardness | Compliance | Coefficient of Friction | | | Contact Temperature Range | |
|--------------------------------------|-----------------------|------------|-------------------------|-------|------|---------------------------|------------|
| | | | Stainless Steel | Steel | UHMW | °F | °C |
| Eagle Blue 80 EC | 80A | EC, FDA | 0.80 | 0.70 | 0.55 | -22 to +150 | -30 to +66 |
| Eagle Clear 80 EC | 80A | EC, FDA | 0.80 | 0.70 | 0.55 | -22 to +150 | -30 to +66 |
| Eagle Blue 80 MD | 80A | FDA | 0.75 | 0.65 | 0.50 | -22 to +150 | -30 to +66 |
| Eagle Opaque 80 | 80A | - | 0.75 | 0.65 | 0.50 | -22 to +150 | -30 to +66 |
| Eagle Orange 85 | 85A | FDA | 0.70 | 0.60 | 0.45 | -22 to +150 | -30 to +66 |
| Eagle Clear 85 | 85A | FDA | 0.70 | 0.60 | 0.45 | -22 to +150 | -30 to +66 |
| Eagle Ivory 85 | 85A | - | 0.70 | 0.60 | 0.45 | -22 to +150 | -30 to +66 |
| Eagle Red 85 | 85A | FDA | 0.70 | 0.60 | 0.45 | -22 to +150 | -30 to +66 |
| Eagle Blue 85 | 85A | FDA | 0.70 | 0.60 | 0.45 | -22 to +150 | -30 to +66 |
| Eagle Green 89 | 89A | - | 0.65 | 0.55 | 0.40 | -22 to +150 | -30 to +66 |
| Eagle Green 89 Textured | 89A | - | 0.50 | 0.40 | 0.30 | -22 to +150 | -30 to +66 |
| Eagle Green 89 T SureConnect* | 89A | - | 0.50 | 0.40 | 0.30 | -22 to +150 | -30 to +66 |
| Eagle Orange 89 SureConnect* | 89A | - | 0.65 | 0.55 | 0.40 | -22 to +150 | -30 to +66 |
| Eagle Red 90 | 90A | - | 0.60 | 0.50 | 0.38 | -22 to +150 | -30 to +66 |
| Eagle Beige 95 | 95A | FDA | 0.55 | 0.45 | 0.35 | -22 to +150 | -30 to +66 |
| Eagle Clear 95 | 95A | FDA | 0.55 | 0.45 | 0.35 | -22 to +150 | -30 to +66 |
| Eagle White 40D | 40D | - | 0.55 | 0.45 | 0.35 | -22 to +176 | -30 to +80 |
| Eagle Blue 55D | 55D | - | 0.50 | 0.40 | 0.30 | -22 to +176 | -30 to +80 |
| Eagle Blue 80 EC QC | 80A | EC, FDA | 0.50 | 0.40 | 0.30 | -22 to +150 | -30 to +66 |
| Eagle Clear 85 QC | 85A | FDA | 0.70 | 0.60 | 0.45 | -22 to +150 | -30 to +66 |
| Eagle Red 85 QC | 85A | - | 0.70 | 0.60 | 0.45 | -22 to +150 | -30 to +66 |
| Eagle Yellow 85 QC | 85A | FDA | 0.70 | 0.60 | 0.45 | -22 to +150 | -30 to +66 |
| Eagle Blue 85 QC | 85A | FDA | 0.70 | 0.60 | 0.45 | -22 to +150 | -30 to +66 |
| Eagle Red 85 CXF | 85A Base, 60A Top | - | 0.70 | 0.60 | 0.45 | -22 to +150 | -30 to +66 |
| Eagle Ivory 85 SGT PU | 85A Base, 70A PU Top | - | 0.70 | 0.60 | 0.45 | -22 to +150 | -30 to +66 |
| Eagle Ivory 85 SGT PVC | 85A Base, 50A PVC Top | - | 0.70 | 0.60 | 0.45 | -22 to +150 | -30 to +66 |
| Eagle Ivory 85 SGT TPE | 85A Base, 55A TPE Top | - | 0.70 | 0.60 | 0.45 | -22 to +150 | -30 to +66 |
| Eagle Green 89 SGT PVC | 89A Base, 50A PVC Top | - | 0.65 | 0.55 | 0.40 | -22 to +150 | -30 to +66 |
| Eagle Red 90 SGT PVC | 90A Base, 50A PVC Top | - | 0.60 | 0.50 | 0.38 | -22 to +150 | -30 to +66 |
| Eagle White 40D SGT PVC | 40D Base, 50A PVC Top | - | 0.55 | 0.45 | 0.35 | -22 to +150 | -30 to +66 |

| REINFORCED Material and Color | Hardness | Compliance | Coefficient of Friction | | | Contact Temperature Range | |
|----------------------------------|-----------------------|------------|-------------------------|-------|------|---------------------------|------------|
| | | | Stainless Steel | Steel | UHMW | °F | °C |
| Eagle Opaque 80 | 80A | - | 0.75 | 0.65 | 0.50 | -22 to +150 | -30 to +66 |
| Eagle Orange 85 | 85A | FDA | 0.70 | 0.60 | 0.45 | -22 to +150 | -30 to +66 |
| Eagle Hyfen 85 | 85A | FDA | 0.70 | 0.60 | 0.45 | -22 to +150 | -30 to +66 |
| Eagle Ivory 85 | 85A | FDA | 0.70 | 0.60 | 0.45 | -22 to +150 | -30 to +66 |
| Eagle Green 89 | 89A | - | 0.65 | 0.55 | 0.40 | -22 to +150 | -30 to +66 |
| Eagle Green 89 Textured | 89A | - | 0.50 | 0.40 | 0.30 | -22 to +150 | -30 to +66 |
| Eagle Beige 95 | 95A | FDA | 0.55 | 0.45 | 0.35 | -22 to +150 | -30 to +66 |
| Eagle Hyfen 95 | 95A | FDA | 0.55 | 0.45 | 0.35 | -22 to +150 | -30 to +66 |
| Eagle Red 50D LCF Can Cable | 50D | - | n/a | n/a | n/a | -22 to +150 | -30 to +66 |
| Eagle Blue 55D Can Cable | 55D | - | n/a | n/a | n/a | -22 to +176 | -30 to +80 |
| Eagle Blue 55D Aramid Can Cable | 55D | - | n/a | n/a | n/a | -22 to +176 | -30 to +80 |
| Eagle Natural 55D Can Cable | 55D | - | n/a | n/a | n/a | -22 to +176 | -30 to +80 |
| Eagle Green 63D Can Cable | 63D | - | n/a | n/a | n/a | -22 to +176 | -30 to +80 |
| Eagle Natural 63D Can Cable | 63D | - | n/a | n/a | n/a | -22 to +176 | -30 to +80 |
| Eagle Ivory 85 RSGT PU | 85A Base, 70A PU Top | - | 0.70 | 0.60 | 0.45 | -22 to +150 | -30 to +66 |
| Eagle Ivory 85 RSGT PVC | 85A Base, 50A PVC Top | - | 0.70 | 0.60 | 0.45 | -22 to +150 | -30 to +66 |
| Eagle Ivory 85 RSGT TPE | 85A Base, 55A TPE Top | - | 0.70 | 0.60 | 0.45 | -22 to +150 | -30 to +66 |
| Eagle Hyfen 85 CXF V | 85A Base, 60A Top | - | 0.70 | 0.60 | 0.45 | -22 to +150 | -30 to +66 |
| Eagle Hyfen 85 CXR V | 85A Base, 60A Top | - | 0.70 | 0.60 | 0.45 | -22 to +150 | -30 to +66 |

* Eagle SureConnect Connectors are Alloy Steel with a RoHS Compliant Zinc Coating

Note: Cogged Belting is not FDA compliant.



| NON-REINFORCED Material and Color | Hardness | Compliance | Contact Temperature Range | |
|--------------------------------------|----------|------------|---------------------------|------------|
| | | | °F | °C |
| Eagle Taper Edge Band | 60D | - | -22 to +176 | -30 to +80 |



| Product | Color | Compliance | Material | Temperature Range | |
|-----------------------------|-----------------------|------------|--|-------------------|--------------|
| | | | | °F | °C |
| Tango Belting | Purple | RoHS | Composite Polyester/Polyurethane | -40 to +240 | -40 to +116 |
| Tango SuperGrip Top PU | Purple, Orange Top | RoHS | Composite Polyester/Polyurethane Polyurethane grip top surface | -22 to +150 | -30 to +66 |
| Tango SuperGrip Top PVC | Purple, Green Top | RoHS | Composite Polyester/Polyurethane PVC grip top surface | -22 to +150 | -30 to +66 |
| Tango Friction Top® | Purple | RoHS | Composite Polyester/Polyurethane | -22 to +150 | -30 to +66 |
| Tango Bridge Top™ | Purple, White Inserts | RoHS | Composite Polyester/Polyurethane PTFE inserts | -40 to +450* | -40 to +232* |
| Tango RCS | Purple, White Tabs | RoHS | Composite Polyester/Polyurethane Polyurethane tabs | -22 to +150 | -30 to +66 |
| PowerTwist Roller Drive™ | Red | RoHS | Composite Polyester/Polyurethane | -22 to +150 | -30 to +66 |
| PowerTwist Plus Antistatic† | Blue | RoHS | Composite Polyester/Polyurethane | -40 to +240 | -40 to +116 |

* Contact temperature

† ISO 1813:1998 inspected and certified by Fenner Drives.

Trackstar®

UHMW BELT & CHAIN GUIDES

Our Trackstar Guides are produced using only the highest quality virgin black UHMW-PE material to ensure minimum friction and maximum wear resistance.

| | ASTM Test | UHMW-PE |
|--|-----------|------------------------|
| Density (gm/cm ³) | D792 | .930 – .936 |
| Tensile Strength at yield (psi at 73°F) | D638 | 3100 |
| Elongation at break (% at 73°F) | D638 | 350 |
| Relative volumetric abrasion loss* | N/A | 100 |
| Coefficient of friction on steel 73°F Static | N/A | .15 – .20 |
| Coefficient of friction on steel 73°F Dynamic | N/A | .10 – .20 |
| Hardness 73°F (Shore D) | D785 | 62 – 66 |
| Coefficient of linear thermal expansion (in/in/°F) | D696 | 1.1 x 10 ⁻⁴ |
| Continuous Service Temp in air (max) (°F) | D696 | 180 |
| Volume Resistivity (Ohm/cm) | D257 | >10 ¹⁵ |

* Industry standard testing method using slurry of 60% aluminum oxide and 40% water at a rotation speed of 1750 rpm for two hours. A lower number indicates better abrasion resistance.

T-Max®

BELT & CHAIN TENSIONERS

| Tensioner Series | Construction | | Operating Temperature Range | |
|--------------------|-------------------|--------------------------|-----------------------------|-------------|
| | Body | Arm | °F | °C |
| RT1000, RT1600 | Die Cast Aluminum | Die Cast Aluminum | -10 to +300 | -23 to +149 |
| RT3000 | Die Cast Aluminum | Heavy Duty Stamped Steel | -20 to +350 | -29 to +177 |
| RT4000 | Die Cast Aluminum | Heavy Duty Stamped Steel | -20 to +350 | -29 to +177 |
| CT1000, 2000, 3000 | Die Cast Aluminum | UHMW Head | -10 to +180 | -23 to +82 |

POWER TRANSMISSION SOLUTIONS



PowerTwist
SUPER T LINK
NU T LINK

PowerTwist, SuperTLink, and NuTLink V Belting

- Provide time and cost saving benefits to maintenance engineers and equipment designers
- Longer belt life in even the harshest environments
- Easier, faster installation without tear-downs or struggling with motor bases
- Install on captive drives and fixed center drives
- Make matching sets
- Better drive efficiency due to minimal belt elongation
- Reduced noise, longer bearing life due to low belt vibration



T-MAX

T-Max Belt and Chain Tensioners

- Automatically take up the slack – decreasing downtime, reducing operating costs and saving energy
- Constructed from high-quality materials for proven durability in harsh environments
- Wide range of tensioners to handle single and multiple strand belt and chain drives



Trantorque
B-LOC

Trantorque and B-LOC Keyless Locking Devices

- A true zero backlash shaft-to-hub connection with none of the operational drawbacks of keyways, shrink fits, or splines
- Extensive inventory – same day shipment available for stock bore sizes: 1/8 – 8", 3 – 600mm
- 18 different internal and external locking devices for any application
- Made-to-Order keyless locking devices for your most demanding applications



RotoShield

RotoShield Gearbox Torque Limiters

- Protect your most expensive machine components from destructive torque overloads
- Instantly disengages before damage occurs
- Easy, fast installation – bolts directly to the motor and gearbox

Link Belting



| POWERTWIST LINK BELTING | Classical Cross Section | Nominal Width | | Part Numbers | | | | Minimum Pulley Ø | | Ride Height Above Rim | | | | | | |
|-------------------------|-------------------------|---------------|----|--------------|-----------|-----------|---------|------------------|---------|-----------------------|--------|-----|----------|----------|---------|---------|
| | | inches | mm | 5' Sleeve | 6' Sleeve | 2m Sleeve | 25' | 100' | 10m | 30m | inches | mm | Min(in.) | Max(in.) | Min(mm) | Max(mm) |
| | | | | | | | | | | | | | | | | |
| PowerTwist® | 3L | 3/8 | 10 | 0418010SL | | | 0405010 | 0408010 | | | 2.00 | | 0.12 | 0.17 | 3.0 | 4.2 |
| PowerTwist | Z/10 | | 10 | | | 04100202 | | | | 0410020 | 45 | | 0.14 | 0.20 | 3.6 | 5.2 |
| PowerTwist | A/4L/13 | 1/2 | 13 | 0418030SL | | 04090502M | 0405030 | 0408030 | 0410030 | 0418033 | 3.00 | 80 | 0.08 | 0.16 | 2.1 | 4.0 |
| PowerTwist | B/5L/17 | 5/8 | 17 | 0418050SL | | 04090302M | 0405050 | 0408050 | 0410050 | 0418053 | 5.00 | 125 | 0.14 | 0.22 | 3.4 | 5.6 |
| PowerTwist | C/22 | 7/8 | 22 | | | | 0405070 | 0408070 | 0410070 | 0418073 | 9.00 | 229 | 0.07 | 0.22 | 1.8 | 5.6 |
| PowerTwist | D/32 | 1-1/4 | 32 | | | | 0405090 | 0408090 | 0410090 | 0418093 | 13.2 | 335 | 0.08 | 0.21 | 2.0 | 5.3 |

| POWERTWIST LINK BELTING | Wedge Cross Section | Nominal Width | | Part Numbers | | | | Minimum Pulley Ø | | Ride Height Above Rim | | | |
|-------------------------|---------------------|---------------|----|--------------|---------|---------|---------|------------------|-----|-----------------------|----------|---------|---------|
| | | inches | mm | 5m | 25' | 100' | 20m | inches | mm | Min(in.) | Max(in.) | Min(mm) | Max(mm) |
| | | | | | | | | | | | | | |
| PowerTwist | 3V | 3/8 | 10 | | 0460025 | 0460000 | | 2.65 | | 0.18 | 0.30 | 4.5 | 7.5 |
| PowerTwist | 5V | 5/8 | 17 | | 0460125 | 0460100 | | 5.5 | | 0.20 | 0.44 | 5.0 | 11.0 |
| PowerTwist | SPZ | | 10 | 0460616 | | | 0460666 | | 67 | 0.18 | 0.30 | 4.5 | 7.5 |
| PowerTwist | SPA | | 13 | 0460716 | | | 0460766 | | 90 | 0.16 | 0.41 | 4.1 | 10.3 |
| PowerTwist | SPB | | 17 | 0460816 | | | 0460866 | | 140 | 0.20 | 0.44 | 5.0 | 11.0 |

| POWERTWIST SPECIALTY LINK BELTING | Cross Section | Nominal Width | | Part Numbers | | | | Minimum Pulley Ø | |
|-----------------------------------|---------------|---------------|----|--------------|----------|-----------|----------|------------------|-----|
| | | inches | mm | 25' | 100' | 10m | 30m | inches | mm |
| | | | | | | | | | |
| PowerTwist Plus Antistatic | A/4L/13 | 1/2 | 13 | 0408505 | 0408501 | 040850010 | 0408500 | 3.00 | 80 |
| PowerTwist Plus Antistatic | B/5L/17 | 5/8 | 17 | 0408605 | 0408601 | 040860010 | 0408600 | 5.00 | 125 |
| PowerTwist Double-V | AA | 1/2 | 13 | 0405230 | 0408230 | | 0419230 | 3.00 | 80 |
| PowerTwist Double-V | BB | 5/8 | 17 | 0405250 | 0408250 | | 0419250 | 5.00 | 125 |
| PowerTwist Double-V | CC | 7/8 | 22 | 0405270 | 0408270 | | 0418270 | 9.00 | 229 |
| PowerTwist Ground Round® | 5/16" | 5/16" | 8 | 04051050 | 04081050 | | 04191050 | 2.00 | 51 |
| PowerTwist Ground Round | 3/8" | 3/8" | 10 | 04051060 | 04081060 | | 0419110 | 3.00 | 76 |
| PowerTwist Ground Round | 1/2" | 1/2" | 13 | 04051040 | 04081040 | | 0419120 | 3.00 | 76 |
| PowerTwist Ground Round | 9/16" | 9/16" | 14 | 04051070 | 04081070 | | 04151070 | 5.50 | 140 |
| PowerTwist Ground Round | 3/4" | 3/4" | 19 | | 04081080 | | 0415110 | 8.50 | 216 |

| SUPERTLINK BELTING | Wedge Cross Section | Nominal Width | | Part Numbers | | | | Minimum Pulley Ø | | Ride Height Above Rim | | | |
|-------------------------|---------------------|---------------|----|--------------|---------|---------|---------|------------------|-----|-----------------------|----------|---------|---------|
| | | inches | mm | 5m | 25' | 100' | 20m | inches | mm | Min(in.) | Max(in.) | Min(mm) | Max(mm) |
| | | | | | | | | | | | | | |
| SuperTLink® | 3V | 0.45 | 11 | | 0407025 | 0407100 | | 2.8 | | 0.18 | 0.40 | 4.6 | 10.0 |
| SuperTLink | 5V | 0.66 | 17 | | 0417025 | 0417100 | | 5.5 | | 0.06 | 0.20 | 1.4 | 5.1 |
| SuperTLink | SPZ | | 10 | L02Z5N | | | L02Z20N | | 71 | 0.18 | 0.40 | 4.6 | 10.0 |
| SuperTLink | SPA | | 13 | L02A5N | | | L02A20N | | 90 | 0.14 | 0.36 | 3.6 | 9.1 |
| SuperTLink | SPB | 0.66 | 17 | L02B5 | | | L02B20 | | 140 | 0.06 | 0.20 | 1.4 | 5.1 |
| SuperTLink | SPC | | 22 | L02C5 | | | L02C20 | | 224 | 0.05 | 0.33 | 1.3 | 8.4 |
| TLink Installation Tool | L02NT10 (10pk) | | | | | | | | | | | | |

| NUTLINK BELTING | Classical Cross Section | Nominal Width | | Part Numbers | | | | Minimum Pulley Ø | | Ride Height Above Rim | | | |
|-------------------------|-------------------------|---------------|----|--------------|--------|--------|-----|------------------|----------|-----------------------|---------|--|--|
| | | inches | mm | 5m | 20m | inches | mm | Min(in.) | Max(in.) | Min(mm) | Max(mm) | | |
| | | | | | | | | | | | | | |
| NuTLink® | Z/10 | | 10 | L01Z5 | L01Z20 | | 45 | 0.06 | 0.18 | 1.6 | 4.6 | | |
| NuTLink | A/13 | 1/2 | 13 | L01A5 | L01A20 | 3.00 | 80 | 0.08 | 0.31 | 2.0 | 7.8 | | |
| NuTLink | B/17 | 5/8 | 17 | L01B5 | L01B20 | 5.00 | 125 | 0.09 | 0.37 | 2.2 | 9.3 | | |
| NuTLink | C/22 | 7/8 | 22 | L01C5 | L01C20 | 9.00 | 229 | 0.00 | 0.23 | 0.1 | 5.8 | | |
| TLink Installation Tool | L02NT10 (10pk) | | | | | | | | | | | | |

T-Max® Belt & Chain Tensioners

Use the following charts to guide your tensioner selection for belt & chain drives.

| V Belt Tensioners | 1 Groove | | | | | | 2 Groove | | | | | | 3 Groove | | | | | | 4 Groove | | | | | | |
|-------------------|----------|---|-----|--------|---|--------|----------|---|-----|--------|---|--------|----------|---|-----|--------|---|--------|----------|---|-----|--------|---|--------|---|
| | Z | A | SPZ | SPA/3V | B | SPB/5V | Z | A | SPZ | SPA/3V | B | SPB/5V | Z | A | SPZ | SPA/3V | B | SPB/5V | Z | A | SPZ | SPA/3V | B | SPB/5V | |
| RT1000-L | X | X | X | X | X | | | | | | | | | | | | | | | | | | | | |
| RT1000 | | X | X | X | X | X | | | | | | | | | | | | | | | | | | | |
| RT3000 | | | | | X | X | X | X | X | X | X | X | X | X | X | X | X | X | X | X | X | X | X | X | X |
| RT4000 | | | | | | | | | | | | X | X | X | X | X | X | X | X | X | X | X | X | X | X |

| Chain Tensioners | Single Chain | | | | | | Double Chain | | | | | |
|------------------|--------------|-----|-----|-----|-----|-----|--------------|-----|-----|-----|-----|--|
| | 35 | 40 | 50 | 60 | 80 | 100 | 35 | 40 | 50 | 60 | 80 | |
| | 06B | 08B | 10B | 12B | 16B | 20B | 06B | 08B | 10B | 12B | 16B | |
| RT1600-L | X | X | X | | | | X | X | | | | |
| RT1600 | | X | X | X | X | | X | X | X | X | | |
| RT1000 | X | X | X | X | X | | X | X | X | X | | |
| RT3000 | | | | X | X | | | | | X | X | |
| RT4100 | | | | | | | | | | | X | |
| RT4900 | | | | | | | | | | | X | |
| CT1000-L | X | X | X | | | | X | X | | | | |
| CT1000 | X | X | X | X | X | X | X | X | X | X | X | |
| CT2000 | | | X | X | X | X | | X | X | X | X | |
| CT3000 | | | | | X | X | | | | | X | |
| CT3000-H | | | | | | X | | | | | | |

Note: Consult Fenner Drives Applications Engineering for any belt or chain application concerns.

T-Max® Belt & Chain Tensioners

RT1000 Series *†

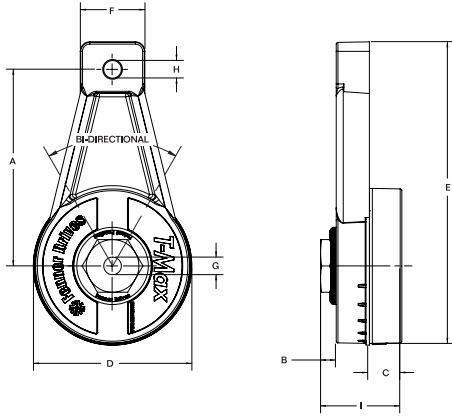

| Part Number | Dimensions (inches) | | | | | | | | | Rotation (degrees) | Force ‡ (lbs) | |
|-------------|---|------|------|------|------|------|--------|--------|------|--------------------|---------------|----|
| | A | B | C | D | E | F | G | H | I | | | |
| RT1001 | 3.50 | 0.29 | 0.59 | 2.76 | 5.37 | 1.15 | 3/8-16 | 3/8-16 | 1.45 | 15 | 16 | |
| | | | | | | | | | | 30 | 23 | |
| | | | | | | | | | | 45 | 30 | |
| RT1003 | 3.50 | 0.29 | 0.59 | 2.76 | 5.37 | 1.15 | 0.40 | 3/8-16 | 1.45 | 15 | 16 | |
| | | | | | | | | | | 30 | 23 | |
| | | | | | | | | | | 45 | 30 | |
| RT1054ZF | 3.50 | 0.29 | 0.59 | 2.76 | 5.37 | 1.15 | 3/8-16 | 3/8-16 | 1.45 | 15 | 16 | |
| | Zerk fitted to apply grease to the spring cavity. | | | | | | | | | | 30 | 23 |
| | | | | | | | | | | 45 | 30 | |
| RT1056ZF | 3.50 | 0.29 | 0.59 | 2.76 | 5.37 | 1.15 | 3/8-16 | 3/8-16 | 1.45 | 15 | 16 | |
| | Zerk fitted to apply grease to the shaft area. | | | | | | | | | | 30 | 23 |
| | | | | | | | | | | 45 | 30 | |

RT1600 Series *†

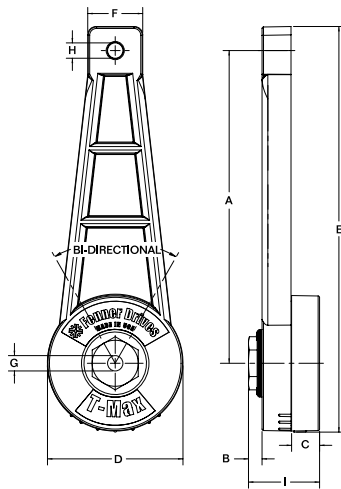

| Part Number | Dimensions (inches) | | | | | | | | | Rotation (degrees) | Force ‡ (lbs) |
|-------------|---------------------|------|------|------|------|------|--------|--------|------|--------------------|---------------|
| | A | B | C | D | E | F | G | H | I | | |
| RT1601-L | 6.37 | 0.29 | 0.59 | 2.76 | 8.24 | 1.12 | 3/8-16 | 3/8-16 | 1.45 | 15 | 10 |
| | | | | | | | | | | 30 | 13 |
| | | | | | | | | | | 45 | 16 |
| RT1603-L | 6.37 | 0.29 | 0.59 | 2.76 | 8.24 | 1.12 | 0.40 | 3/8-16 | 1.45 | 15 | 10 |
| | | | | | | | | | | 30 | 13 |
| | | | | | | | | | | 45 | 16 |
| RT1601 | 6.37 | 0.29 | 0.59 | 2.76 | 8.24 | 1.12 | 3/8-16 | 3/8-16 | 1.45 | 15 | 20 |
| | | | | | | | | | | 25 | 23 |
| | | | | | | | | | | 35 | 26 |
| RT1603 | 6.37 | 0.29 | 0.59 | 2.76 | 8.24 | 1.12 | 0.40 | 3/8-16 | 1.45 | 15 | 20 |
| | | | | | | | | | | 25 | 23 |
| | | | | | | | | | | 35 | 26 |

RT3000 Series *

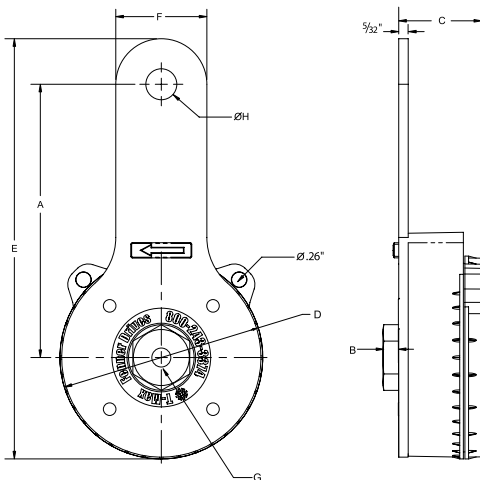

| Part Number | Dimensions (inches) | | | | | | | | Rotation (degrees) | Force ‡ (lbs) |
|-------------|---------------------|------|------|------|------|------|--------|------|--------------------|---------------|
| | A | B | C | D | E | F | G | H | | |
| RT3000 | 4.50 | 0.28 | 1.35 | 3.34 | 6.92 | 1.50 | 3/8-16 | 0.51 | 0 - 70 | 0 - 42 |
| RT3001 | 4.50 | 0.28 | 1.35 | 3.34 | 6.92 | 1.50 | 0.40 | 0.51 | 0 - 70 | 0 - 42 |

* Maximum load no more than 1" distance from front face of tensioner to centerline of idler.
 † Do not use on reciprocating applications such as IC engines and piston devices.
 ‡ All forces (lbs.) are nominal.

T-Max® Tensioners

RT4100 Series *†

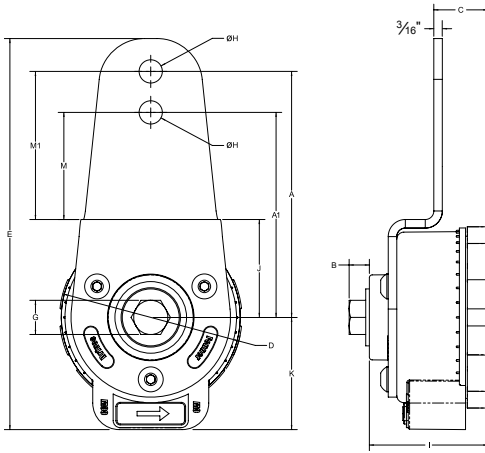

| Part Number | Dimensions (inches) | | | | | | | | | | | | | | Rotation (degrees) | Force ‡ (lbs) |
|-------------|---------------------|------|------|------|------|------|----------|------|------|------|------|------|------|--------|--------------------|---------------|
| | A | A1 | B | C | D | E | G | H | I | J | K | M | M1 | | | |
| RT4100 | 5.40 | 4.50 | 0.47 | 1.19 | 4.00 | 8.58 | 1/2 - 13 | 0.51 | 2.60 | 2.15 | 2.46 | 2.35 | 3.25 | 0 - 85 | 0 - 85 | |
| RT4101 | 5.40 | 4.50 | N/A | 1.19 | 4.00 | 8.58 | 0.51 | 0.51 | 2.60 | 2.15 | 2.46 | 2.35 | 3.25 | 0 - 85 | 0 - 85 | |

RT4900 Series *†

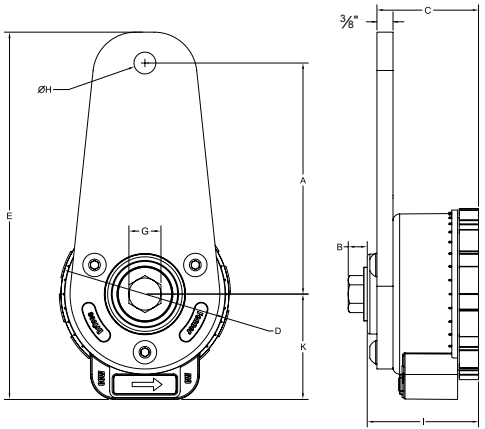

| Part Number | Dimensions (inches) | | | | | | | | | | Rotation § (degrees) | Force § (lbs) |
|-------------|---------------------|------|------|------|------|----------|------|------|------|--------|----------------------|---------------|
| | A | B | C | D | E | G | H | I | K | | | |
| RT4900 | 5.40 | N/A | 2.37 | 4.00 | 8.58 | 0.51 | 0.51 | 2.60 | 2.46 | 0 - 85 | 0 - 70 | |
| RT4902 | 5.40 | 0.47 | 2.37 | 4.00 | 8.58 | 1/2 - 13 | 0.51 | 2.60 | 2.46 | 0 - 85 | 0 - 70 | |

PowerMax DriveN Pulleys

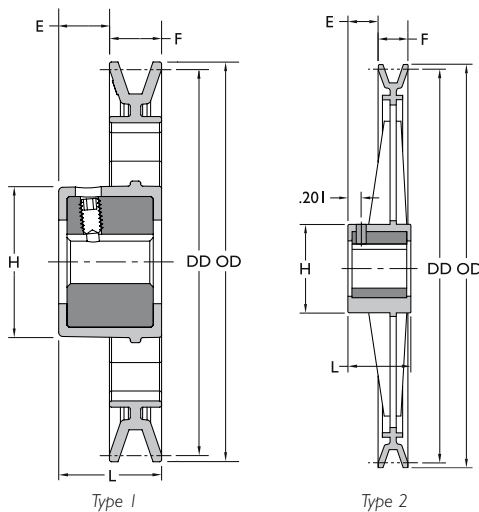

| Base Part Number | Dimensions (inches) | | | | | | Belt Size | Diameter (inches) | | Number Spokes | Spoke Style |
|------------------|---------------------|------|------|------|------|---------|-----------|-------------------|---|---------------|-------------|
| | Type | E | F | H | L | Outside | | Datum | | | |
| AFD44 | 1 | 0.79 | 0.74 | 2.17 | 1.53 | A/4L | 4.25 | 4 | - | - | |
| AFD49 | 1 | 0.79 | 0.74 | 2.17 | 1.53 | A/4L | 4.75 | 4.5 | 4 | I-Beam | |
| AFD59 | 1 | 0.79 | 0.74 | 2.17 | 1.53 | A/4L | 5.75 | 5.5 | 4 | I-Beam | |
| AFD74 | 1 | 0.79 | 0.74 | 2.17 | 1.53 | A/4L | 7.25 | 7 | 4 | I-Beam | |
| AFD84 | 2 | 0.76 | 0.75 | 2.22 | 1.6 | A/4L | 8.25 | 8 | 6 | Cross | |
| AFD94 | 2 | 0.76 | 0.75 | 2.22 | 1.6 | A/4L | 9.25 | 9 | 6 | Cross | |
| AFD104 | 2 | 0.76 | 0.75 | 2.22 | 1.6 | A/4L | 10.25 | 10 | 6 | Cross | |
| AFD112 | 2 | 0.76 | 0.75 | 2.22 | 1.6 | A/4L | 10.98 | 10.73 | 6 | Cross | |
| AFD124 | 2 | 0.75 | 0.75 | 2.22 | 1.6 | A/4L | 12.25 | 12 | 6 | I-Beam | |

| Shaft Size | Keyseat |
|------------|---------------|
| 5/8", 3/4" | 3/16" x 3/32" |
| 1" | 1/4" x 1/8" |

Part Number Ordering Guide

| Base Part Number | + | Shaft Size | = | Complete Part Number |
|------------------|---|------------|---|----------------------|
| AFD44 | | 5/8" | | AFD4458 |
| AFD94 | | 1" | | AFD94100 |

Note: PowerMax DriveN Pulleys are not recommended to be used as driveR pulleys.

* Maximum load no more than 1 1/2" distance from front face of tensioner arm to centerline of idler.
 † Requires a fixed head, hook style spanner wrench for tensioning (supplied with unit).
 ‡ Dimension A: 1° rotation = .83 lb. force.
 § Dimension A1: 1° rotation = 1 lb. force. All forces (lbs.) are nominal.
 § 1° rotation = .83 lb. force. All forces (lbs.) are nominal.

RotoShield™ Gearbox Torque Limiters

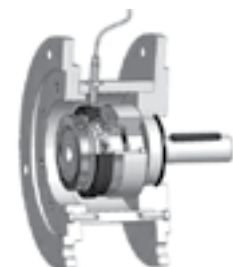

| Base Part Number | NEMA Motor size | Torque Range in-lb | Flange OD inch | Bolt Circle Diameter inch | Unit Width inch | Shaft/Bore Diameter inch | Shaft Length inch | Max Speed rpm | Weight lb |
|------------------|-----------------|--------------------|----------------|---------------------------|-----------------|--------------------------|-------------------|---------------|-----------|
| GTL56 | 56C | 44.3 - 442.5 | 6.6 | 5.875 | 3.07 | 5/8 H7/h7 | 1.88 | 4000 | 16.3 |
| GTL143 | 143 TC | 44.3 - 442.5 | 6.6 | 5.875 | 3.07 | 7/8 H7/h7 | 2.25 | 4000 | 16.3 |
| GTL184 | 184 TC | 177 - 1770.1 | 8.9 | 7.250 | 4.4 | 1-1/8 H7/h7 | 2.75 | 2500 | 39.6 |
| GTL215 | 215 TC | 309.8 - 3673.1 | 8.9 | 7.250 | 4.64 | 1-3/8 H7/h7 | 3.38 | 2000 | 42.9 |
| GTL256 | 256 TC | 309.8 - 3673.1 | 8.9 | 7.250 | 5.26 | 1-5/8 H7/h7 | 4.00 | 2000 | 48.4 |

| Base Part Number | IEC Motor size | Torque Range Nm | Flange OD mm | Bolt Circle Diameter mm | Unit Width mm | Shaft/Bore Diameter mm | Shaft Length mm | Max Speed rpm | Weight kg |
|------------------|----------------|-----------------|--------------|-------------------------|---------------|------------------------|-----------------|---------------|-----------|
| GTL63 | 63 | 3 - 23 | 140 | 115 | 52.5 | 11 H7/h7 | 23 | 4000 | 4 |
| GTL71 | 71 | 3 - 23 | 160 | 130 | 55 | 14 H7/h7 | 30 | 4000 | 4.5 |
| GTL80 | 80 | 5 - 50 | 200 | 165 | 78 | 19 H7/h7 | 40 | 4000 | 8.5 |
| GTL90 | 90 | 9 - 100 | 200 | 165 | 90 | 24 H7/h7 | 50 | 3000 | 10 |
| GTL100 | 100La | 20 - 200 | 250 | 215 | 110 | 28 H7/h7 | 60 | 2500 | 18 |
| GTL132 | 132M | 35 - 415 | 300 | 265 | 110 | 38 H7/h7 | 80 | 2000 | 25.5 |
| GTL160 | 160 | 75 - 720 | 350 | 300 | 126 | 42 H7/h7 | 110 | 1850 | 35 |
| GTL180 | 180 | 75 - 720 | 350 | 300 | 126 | 48 H7/h7 | 110 | 1850 | 35 |

Note: All units are IP67 rated

| PART NUMBER BUILDER | | |
|---------------------|---------|----------------------|
| Base Part Number | Torque* | Complete Part Number |
| GTL56 | + 115 | = GTL56-115 |

*Torque in in-lb for NEMA and Nm for IEC.

PRX – Inductive Proximity Sensor



- Electric contact 7 - 30 VCC/Vdc and working frequency 4000 Hz
- Operating temperature: -13°F to +158°F (-25°C to +70°C)
- Cable length: 6.5ft (2m)

Material Properties



| Product | Color | Compliance | Material | Temperature Range | |
|---------------------------|---------------------------------|-------------|--|-------------------|-------------|
| | | | | °F | °C |
| PowerTwist | Red (classical) Blue (wedge) | RoHS, Reach | Composite Polyester/Polyurethane | -40 to +240 | -40 to +116 |
| PowerTwist® Ground Round® | Red | RoHS, Reach | Composite Polyester/Polyurethane | -40 to +240 | -40 to +116 |
| PowerTwist Antistatic* | Blue | RoHS | Composite Polyester/Polyurethane | -40 to +240 | -40 to +116 |
| SuperTLink | Blue | RoHS | Composite Polyester/Polyurethane Steel Rivets | -40 to +240 | -40 to +116 |
| NuTLink | Orange | RoHS | Composite Polyester/Polyurethane Steel Rivets | -40 to +240 | -40 to +116 |

* ISO 1813:1998 inspected and certified by Fenner Drives.



| Tensioner Series | Construction | | Operating Temperature Range | |
|--------------------|-------------------|--------------------------|-----------------------------|-------------|
| | Body | Arm | °F | °C |
| RT1000, RT1600 | Die Cast Aluminum | Die Cast Aluminum | -10 to +300 | -23 to +149 |
| RT3000 | Die Cast Aluminum | Heavy Duty Stamped Steel | -20 to +350 | -29 to +177 |
| RT4000 | Die Cast Aluminum | Heavy Duty Stamped Steel | -20 to +350 | -29 to +177 |
| CT1000, 2000, 3000 | Die Cast Aluminum | UHMW Head | -10 to +180 | -23 to +82 |

Trantorque® or B-LOC®: the Enduring Question

Once you have decided that a keyless locking device is the right solution, your next big decision is which series of Fenner Drives Trantorque or B-LOC Keyless Locking Device to choose. While the underlying engineering principle for both Trantorque and B-LOC is exactly the same, the functionality of each may appeal to different applications and situations.

| SELECTION ASSISTANCE | Shaft Size Range | Overall Length Range | Torque Transmission | Axial Movement | Self Centering | Concentricity |
|-------------------------------|---------------------------------|------------------------------------|---|---------------------|----------------|-------------------|
| Trantorque GT | 5/8 – 3 in; 15 – 75mm | 1 1/2 – 4 1/4 in; 38.1 – 108mm | 153 – 1,444 ft lb; 196 – 1,939 Nm | ~0.075 in (1.9mm) | Yes | Excellent |
| Trantorque Mini | 1/8 – 5/8 in; 3 – 16mm | 3/4 – 1 1/8 in; 19 – 29mm | 91 – 1,234 in lb; 10 – 140 Nm | ~0.045 in (1.1mm) | Yes | Excellent |
| Trantorque Micro | 1/8 – 5/8 in; 3 – 16mm | 5/8 – 1 1/2 in; 15.8 – 38.1mm | 44 – 282 ft lb; 5 – 32 Nm | ~0.0375 in (0.95mm) | Yes | Excellent |
| Trantorque OE | 1 1/16 – 1 1/2 in; 17 – 35mm | 1 5/32 – 1 25/32 in; 29 – 43mm | 162 – 492 ft lb; 211 – 658 Nm | ~0.075 in (1.9mm) | Yes | Excellent |
| Trantorque NT | 3/16 – 2 in | 1 1/16 – 4 3/4 in | 7 – 561 ft lb | No | Yes | Excellent |
| B-LOC B109 | 1/4 – 1 3/8 in; 6 – 35mm | 0.650 – 1.102 in; 16.5 – 28.5mm | 167 – 5,929 in lb; 19 – 683 Nm | No | Yes | Excellent |
| B-LOC B103 | 3/4 – 8 in; 15 – 400mm | 1.122 – 2.559 in; 21.5 – 116mm | 247 – 48,913 ft lb; 115 – 489,701 Nm | ~0.032 in (0.8mm) | Yes | Excellent |
| B-LOC B106 | 5/8 – 8 in; 14 – 400mm | 0.846 – 2.559 in; 20.5 – 116mm | 55 – 37,959 ft lb; 68 – 372,590 Nm | No | Yes | Excellent |
| B-LOC B800 | 1/4 – 4 15/16 in; 6 – 130mm | 0.866 – 5.039 in; 22 – 128mm | 16 – 18,362 ft lb; 22 – 25,742 Nm | No | Yes | Excellent |
| B-LOC B400 | 3/4 – 8 in; 18 – 500mm | 0.787 – 2.047 in; 20 – 102mm | 234 – 53,827 ft lb; 302 – 814,734 Nm | No | No | Fair |
| B-LOC B112 | 1 – 8 in; 24 – 600mm | 1.575 – 5.866 in; 40 – 203mm | 600 – 110,469 ft lb; 755 – 1,756,139 Nm | No | Yes | Excellent |
| B-LOC B115 | 2 3/4 – 8 in; 70 – 600mm | 2.441 – 4.134 in; 62 – 160mm | 5,261 – 70,109 ft lb; 7,118 – 1,228,856 Nm | No | Yes | Excellent |
| B-LOC B113 | 180 – 560mm | 231 – 280mm | 223,566 – 2,342,897 Nm | No | Yes | Excellent |
| B-LOC B117 | 180 – 600mm | 122 – 178mm | 87,000 – 1,080,000 Nm | No | Yes | Excellent |
| B-LOC Compression Hubs | 1/2 – 3 in; 12 – 75mm | 0.708 – 2.224 in 18.1 – 56.6mm | 48 - 4797 ft lb; 65 – 6400 Nm | No | Yes | Fair to Excellent |
| B-LOC Shrink Discs | 5/8 – 21.26 in; 15 – 540mm | 0.71 – 11.26 in; 22 – 286 mm | 139 – 3,267,568 ft lb | No | Yes | Excellent |
| B-LOC WK Couplings | 3/8 - 4-1/4 in; 16 – 105mm | 1.339 – 4.960 in; 34 -126mm | 132 – 19810 ft-lb; 179 – 26859 Nm | No | Yes | Excellent |

| | Balance | Self-Locking Tapers | Recessed Installation Without Counterbore | RoHS Compliant |
|--|-----------|---------------------|---|----------------|
| | Excellent | Yes | No | Yes |
| | Very Good | Yes | No | Yes |
| | Very Good | No | No | Yes |
| | Excellent | Yes | No | Yes |
| | Very Good | Yes | No | Yes |
| | Excellent | Yes | No | Yes |
| | Excellent | Yes | Yes | Yes |
| | Excellent | Yes | No | Yes |
| | Excellent | Yes | No | Yes |
| | Very Good | No | Yes | No |
| | Excellent | Yes | Yes | Yes |
| | Excellent | Yes | Yes | Yes |
| | Excellent | Yes | No | Yes |
| | Excellent | No | N/A | Yes |
| | Excellent | No | N/A | No |
| | Excellent | No | N/A | Yes |

Internal or External

At the broadest level, keyless locking devices may be split into two categories, internal locking devices (Trantorque and B-LOC Keyless Bushings) and external locking devices (B-LOC Shrink Discs, WK Couplings, and Compression Hubs). Selecting an external locking device is relatively straightforward. If you are joining two solid shafts at their ends, see the section on B-LOC WK Couplings. To connect most industry standard coupling hubs or flanges, gearboxes with hollow-shaft outputs, or other similar geometries see the B-LOC Shrink Disc section. If the component you are mounting has a narrow hub or has a short length through-bore, like a plate sprocket, see the section on B-LOC Compression Hubs.

Most applications, however, consist of a shaft and bored component that require the use of a keyless bushing. Many more factors play into the proper selection of a keyless bushing and are briefly addressed below and in the accompanying table.

Shaft Size

Shaft size may immediately determine whether you use a Trantorque or B-LOC Keyless Bushing. A Trantorque can accommodate shaft sizes as small as 1/8" (3mm) while the smallest shaft a B-LOC will fit is 1/4" (6mm). At the other end of the spectrum, Trantorque tops out at 3" (75mm) and the largest B-LOC will accommodate shafts approaching 24" (600mm). Larger and smaller versions of all units may be available as MTOs (Made To Order).

As a practical matter, under most circumstances our Application Engineers will recommend a Trantorque for shaft sizes 1-1/2" and under and a B-LOC for shaft sizes over 1-1/2". These are considered the optimal ranges for the product lines taking maximum advantage of each product's unique installation method.

Installation

The most obvious difference when comparing a B-LOC to a Trantorque Keyless Bushing is the installation method. All B-LOC units use a plurality of screws; all Trantorque units use a single hex nut. Your particular application will be your guide as to which method is preferred.

The advantages of a single hex nut, as used in a Trantorque Keyless Bushing, are speed and simplicity of installation and removal. For installation, simply tighten the single hex nut to the specified installation torque and your connection is complete. Removal is just as straightforward. Merely loosen the same hex nut and the unit will disengage. The cost for this simplicity is a relatively high installation torque requirement, which may present a challenge for larger units.

Since the force needed to draw the mating tapers of a B-LOC Keyless Bushing together is distributed among many screws, the installation torque of an individual screw is relatively low. This allows for effortless installation of even the largest units. The price paid for this low installation torque is a more timely and complex installation and removal process. The screws must be slowly and equally tightened in series until the final installation torque is achieved. Since most B-LOC units have self locking tapers, the removal process requires loosening all screws and backing off the unit.

Other Considerations

There are several other design points that may help guide you in your selection process. OD to ID ratios vary widely from product to product. If your design requires a small OD/ID ratio, consider either a B-LOC B800 or a Trantorque OE. While all Fenner Drives Keyless Bushings are designed to transmit high torque loads, if you have an extremely demanding application, a double taper B-LOC B112, B113 or B115 may be required. If you are mounting plate sprockets or other thin components, B-LOC Compression Hubs could be the solution. Other factors to consider include axial movement, recessed installation, corrosion protection, and RoHS compliance. The table is designed to help make your selection process easier, but if you are ever in doubt, please contact a Fenner Drives Applications Engineer at AE@fennerdrives.com. We will be happy to guide you to the perfect keyless locking device solution.

Trantorque®
GT
Inch

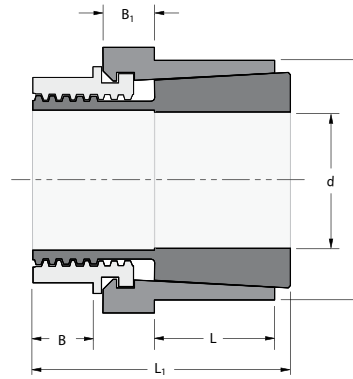
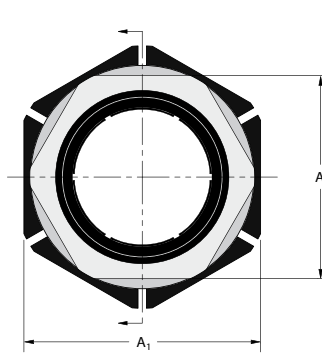

TOLERANCE (T_L)

T_L for shaft and bore is ± .003" for all sizes

Trantorque GT – Inch

| Part Number | | | | d (inch) | D (inch) | L (inch) | L ₁ (inch) | Wrench Size | | | | M _a | Shipping Weight (lb) |
|-------------|---------------------------------|--------------------------------|-----------------|----------|----------|----------|-----------------------|-------------|-----------------------|----------|-----------------------|----------------|----------------------|
| Steel | Electroless Nickel Plated Steel | Thin Dense Chrome Coated Steel | Stainless Steel | | | | | A (inch) | A ₁ (inch) | B (inch) | B ₁ (inch) | | |
| 6202120UP | 6202120EN | 6202120DC | 6990120 | 5/8 | 1 1/2 | 3/4 | 1 1/2 | 1 1/4 | 1 1/2 | 5/16 | 5/16 | 100 | 0.5 |
| 6202140UP | 6202140EN | 6202140DC | 6990140 | 11/16 | 1 1/2 | 3/4 | 1 1/2 | 1 1/4 | 1 1/2 | 5/16 | 5/16 | 100 | 0.5 |
| 6202160UP | 6202160EN | 6202160DC | 6990160 | 3/4 | 1 1/2 | 3/4 | 1 1/2 | 1 1/4 | 1 1/2 | 5/16 | 5/16 | 100 | 0.5 |
| 6202190UP | 6202190EN | 6202190DC | 6990190 | 13/16 | 1 3/4 | 7/8 | 1 7/8 | 1 1/2 | 1 3/4 | 7/16 | 3/8 | 125 | 0.7 |
| 6202200UP | 6202200EN | 6202200DC | 6990200 | 7/8 | 1 3/4 | 7/8 | 1 7/8 | 1 1/2 | 1 3/4 | 7/16 | 3/8 | 125 | 0.7 |
| 6202220UP | 6202220EN | 6202220DC | 6990220 | 15/16 | 1 3/4 | 7/8 | 1 7/8 | 1 1/2 | 1 3/4 | 7/16 | 3/8 | 125 | 0.7 |
| 6202240UP | 6202240EN | 6202240DC | 6990240 | 1 | 1 3/4 | 7/8 | 1 7/8 | 1 1/2 | 1 3/4 | 7/16 | 3/8 | 125 | 0.7 |
| 6202270UP | 6202270EN | 6202270DC | 6990270 | 1 1/16 | 2 | 1 | 2 1/4 | 1 3/4 | 2 | 1/2 | 9/16 | 167 | 1.1 |
| 6202280UP | 6202280EN | 6202280DC | 6990280 | 1 1/8 | 2 | 1 | 2 1/4 | 1 3/4 | 2 | 1/2 | 9/16 | 167 | 1.1 |
| 6202300UP | 6202300EN | 6202300DC | 6990300 | 1 3/16 | 2 | 1 | 2 1/4 | 1 3/4 | 2 | 1/2 | 9/16 | 167 | 1.1 |
| 6202320UP | 6202320EN | 6202320DC | 6990320 | 1 1/4 | 2 | 1 | 2 1/4 | 1 3/4 | 2 | 1/2 | 9/16 | 167 | 1.1 |
| 6202350UP | 6202350EN | 6202350DC | 6990350 | 1 5/16 | 2 3/8 | 1 1/2 | 2 3/4 | 2 | 2 3/8 | 9/16 | 1/2 | 192 | 1.1 |
| 6202360UP | 6202360EN | 6202360DC | 6990360 | 1 3/8 | 2 3/8 | 1 1/2 | 2 3/4 | 2 | 2 3/8 | 9/16 | 1/2 | 192 | 1.9 |
| 6202380UP | 6202380EN | 6202380DC | 6990380 | 1 7/16 | 2 3/8 | 1 1/2 | 2 3/4 | 2 | 2 3/8 | 9/16 | 1/2 | 192 | 1.8 |
| 6202400UP | 6202400EN | 6202400DC | 6990400 | 1 1/2 | 2 3/8 | 1 1/2 | 2 3/4 | 2 | 2 3/8 | 9/16 | 1/2 | 192 | 1.8 |
| 6202430UP | 6202430EN | 6202430DC | 6990430 | 1 9/16 | 2 5/8 | 1 11/16 | 3 1/8 | 2 1/4 | 2 5/8 | 9/16 | 11/16 | 234 | 2.5 |
| 6202440UP | 6202440EN | 6202440DC | 6990440 | 1 5/8 | 2 5/8 | 1 11/16 | 3 1/8 | 2 1/4 | 2 5/8 | 9/16 | 11/16 | 234 | 2.4 |
| 6202460UP | 6202460EN | 6202460DC | 6990460 | 1 11/16 | 2 5/8 | 1 11/16 | 3 1/8 | 2 1/4 | 2 5/8 | 9/16 | 11/16 | 234 | 2.4 |
| 6202480UP | 6202480EN | 6202480DC | 6990480 | 1 3/4 | 2 5/8 | 1 11/16 | 3 1/8 | 2 1/4 | 2 5/8 | 9/16 | 11/16 | 234 | 2.3 |
| 6202510UP | 6202510EN | 6202510DC | 6990510 | 1 13/16 | 2 7/8 | 2 | 3 9/16 | 2 1/2 | 2 7/8 | 5/8 | 3/4 | 409 | 3.5 |
| 6202520UP | 6202520EN | 6202520DC | 6990520 | 1 7/8 | 2 7/8 | 2 | 3 9/16 | 2 1/2 | 2 7/8 | 5/8 | 3/4 | 409 | 3.4 |
| 6202540UP | 6202540EN | 6202540DC | 6990540 | 1 15/16 | 2 7/8 | 2 | 3 9/16 | 2 1/2 | 2 7/8 | 5/8 | 3/4 | 409 | 3.3 |
| 6202560UP | 6202560EN | 6202560DC | 6990560 | 2 | 2 7/8 | 2 | 3 9/16 | 2 1/2 | 2 7/8 | 5/8 | 3/4 | 409 | 3.2 |
| 6202562UP | 6202562EN | 6202562DC | 6990562 | 2 1/16 | 3 1/8 | 2 1/8 | 3 3/4 | 2 3/4 | 3 1/8 | 5/8 | 13/16 | 442 | 3.8 |
| 6202564UP | 6202564EN | 6202564DC | 6990564 | 2 1/8 | 3 1/8 | 2 1/8 | 3 3/4 | 2 3/4 | 3 1/8 | 5/8 | 13/16 | 442 | 4 |
| 6202566UP | 6202566EN | 6202566DC | 6990566 | 2 3/16 | 3 1/8 | 2 1/8 | 3 3/4 | 2 3/4 | 3 1/8 | 5/8 | 13/16 | 442 | 3.8 |
| 6202568UP | 6202568EN | 6202568DC | 6990568 | 2 1/4 | 3 1/8 | 2 1/8 | 3 3/4 | 2 3/4 | 3 1/8 | 5/8 | 13/16 | 442 | 3.7 |
| 6202570UP | 6202570EN | 6202570DC | 6990570 | 2 5/16 | 3 3/8 | 2 1/4 | 3 7/8 | 3 | 3 3/8 | 11/16 | 3/4 | 467 | 4.4 |
| 6202572UP | 6202572EN | 6202572DC | 6990572 | 2 3/8 | 3 3/8 | 2 1/4 | 3 7/8 | 3 | 3 3/8 | 11/16 | 3/4 | 467 | 4.5 |
| 6202574UP | 6202574EN | 6202574DC | 6990574 | 2 7/16 | 3 3/8 | 2 1/4 | 3 7/8 | 3 | 3 3/8 | 11/16 | 3/4 | 467 | 4.4 |
| 6202576UP | 6202576EN | 6202576DC | 6990576 | 2 1/2 | 3 3/8 | 2 1/4 | 3 7/8 | 3 | 3 3/8 | 11/16 | 3/4 | 467 | 4.2 |
| 6202580UP | 6202580EN | 6202580DC | 6990580 | 2 9/16 | 3 5/8 | 2 3/8 | 4 1/16 | 3 1/4 | 3 5/8 | 11/16 | 13/16 | 500 | 5 |
| 6202582UP | 6202582EN | 6202582DC | 6990582 | 2 5/8 | 3 5/8 | 2 3/8 | 4 1/16 | 3 1/4 | 3 5/8 | 11/16 | 13/16 | 500 | 5.1 |
| 6202584UP | 6202584EN | 6202584DC | 6990584 | 2 11/16 | 3 5/8 | 2 3/8 | 4 1/16 | 3 1/4 | 3 5/8 | 11/16 | 13/16 | 500 | 5 |
| 6202586UP | 6202586EN | 6202586DC | 6990586 | 2 3/4 | 3 5/8 | 2 3/8 | 4 1/16 | 3 1/4 | 3 5/8 | 11/16 | 13/16 | 500 | 5 |
| 6202590UP | 6202590EN | 6202590DC | 6990590 | 2 13/16 | 3 7/8 | 2 1/2 | 4 1/4 | 3 1/2 | 3 7/8 | 3/4 | 13/16 | 550 | 6 |
| 6202592UP | 6202592EN | 6202592DC | 6990592 | 2 7/8 | 3 7/8 | 2 1/2 | 4 1/4 | 3 1/2 | 3 7/8 | 3/4 | 13/16 | 550 | 6 |
| 6202594UP | 6202594EN | 6202594DC | 6990594 | 2 15/16 | 3 7/8 | 2 1/2 | 4 1/4 | 3 1/2 | 3 7/8 | 3/4 | 13/16 | 550 | 6 |
| 6202596UP | 6202596EN | 6202596DC | 6990596 | 3 | 3 7/8 | 2 1/2 | 4 1/4 | 3 1/2 | 3 7/8 | 3/4 | 13/16 | 550 | 5 |

Performance Data Table

| d (inch) | M _t | T _h | P _h * |
|-------------|---------------------|----------------|--------------------|
| | Maximum Transmitted | | Hub Pressure (psi) |
| | Torque (ft lb) | Thrust (lbs) | |
| 5/8 | 153 | 5857 | 13347 |
| 11/16 | 168 | 5857 | 13347 |
| 3/4 | 183 | 5857 | 13347 |
| 13/16 | 207 | 6110 | 9336 |
| 7/8 | 223 | 6110 | 9336 |
| 15/16 | 239 | 6110 | 9336 |
| 1 | 255 | 6110 | 9336 |
| 1 1/16 | 311 | 7014 | 8313 |
| 1 1/8 | 329 | 7014 | 8313 |
| 1 3/16 | 347 | 7014 | 8313 |
| 1 1/4 | 365 | 7014 | 8313 |
| 1 5/16 | 384 | 7019 | 4842 |
| 1 3/8 | 402 | 7019 | 4842 |
| 1 7/16 | 421 | 7019 | 4842 |
| 1 1/2 | 439 | 7019 | 4842 |
| 1 9/16 | 499 | 7663 | 4287 |
| 1 5/8 | 519 | 7663 | 4287 |
| 1 11/16 | 539 | 7663 | 4287 |
| 1 3/4 | 559 | 7663 | 4287 |
| 1 13/16 | 913 | 12085 | 5257 |
| 1 7/8 | 944 | 12085 | 5257 |
| 1 15/16 | 976 | 12085 | 5257 |
| 2 | 1007 | 12085 | 5257 |
| 2 1/16 | 1013 | 11793 | 4457 |
| 2 1/8 | 1044 | 11793 | 4457 |
| 2 3/16 | 1075 | 11793 | 4457 |
| 2 1/4 | 1106 | 11793 | 4457 |
| 2 5/16 | 1101 | 11430 | 3789 |
| 2 3/8 | 1131 | 11430 | 3789 |
| 2 7/16 | 1161 | 11430 | 3789 |
| 2 1/2 | 1191 | 11430 | 3789 |
| 2 9/16 | 1207 | 11306 | 3313 |
| 2 5/8 | 1237 | 11306 | 3313 |
| 2 11/16 | 1266 | 11306 | 3313 |
| 2 3/4 | 1295 | 11306 | 3313 |
| 2 13/16 | 1354 | 11555 | 3014 |
| 2 7/8 | 1384 | 11555 | 3014 |
| 2 15/16 | 1414 | 11555 | 3014 |
| 3 | 1444 | 11555 | 3014 |

MULTIPLIERS

| | |
|------------------------------------|-----|
| Steel | 1.0 |
| Electroless Nickel Plated Steel | 0.6 |
| Thin Dense Chrome Coated Steel | 1.1 |
| Stainless Steel | 0.3 |

The data in the Performance Data Table is for a steel unit. To obtain data for other materials, use the multiplier provided.

For example, you require a 2" (d) Electroless Nickel Plated Trantorque GT.

Find 2" (d) in Performance Data Table and use the multiplier of 0.6 for Electroless Nickel Plated Steel.

$$M_t : 1007 \times 0.6 = 604$$

$$T_h : 12085 \times 0.6 = 7251$$

$$*P_h : 5257 \times 0.6 = 3154$$

***IMPORTANT:**

After hub pressure (P_h) is determined, record D, L and P_h and refer to page 70 to calculate the minimum hub diameter.

Trantorque®
GT
Metric

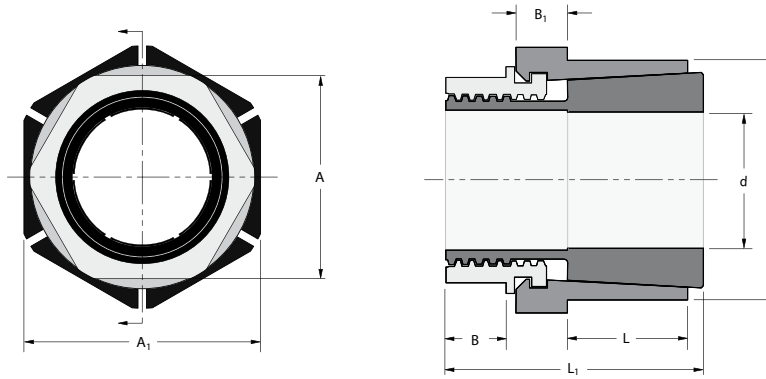

TOLERANCE (T_L)

T_L for shaft and bore is $\pm .08\text{mm}$ for all sizes

Trantorque GT – Metric

| Part Number | | | | d (mm) | D (mm) | L (mm) | L1 (mm) | Wrench Size | | B (mm) | B1 (mm) | M _a | Shipping Weight (kg) |
|-------------|---------------------------------|--------------------------------|-----------------|--------|--------|--------|---------|-------------|-----------|--------|---------|----------------|----------------------|
| Steel | Electroless Nickel Plated Steel | Thin Dense Chrome Coated Steel | Stainless Steel | | | | | A (mm) | A1 (inch) | | | | |
| 6202800UP | 6202800EN | 6202800DC | 6990800 | 15 | 38.0 | 19.1 | 38.1 | 32 | 1 1/2 | 8.0 | 8.9 | 136 | 0.2 |
| 6202803UP | 6202803EN | 6202803DC | 6990803 | 16 | 38.0 | 19.1 | 38.1 | 32 | 1 1/2 | 8.0 | 8.9 | 136 | 0.2 |
| 6202804UP | 6202804EN | 6202804DC | 6990804 | 17 | 38.0 | 19.1 | 38.1 | 32 | 1 1/2 | 8.0 | 8.9 | 136 | 0.2 |
| 6202805UP | 6202805EN | 6202805DC | 6990805 | 18 | 38.0 | 19.1 | 38.1 | 32 | 1 1/2 | 8.0 | 8.9 | 136 | 0.2 |
| 6202808UP | 6202808EN | 6202808DC | 6990808 | 19 | 38.0 | 19.1 | 38.1 | 32 | 1 1/2 | 8.0 | 8.9 | 136 | 0.2 |
| 6202811UP | 6202811EN | 6202811DC | 6990811 | 20 | 45.0 | 22.2 | 47.6 | 38 | 1 3/4 | 11.1 | 9.5 | 170 | 0.4 |
| 6202815UP | 6202815EN | 6202815DC | 6990815 | 22 | 45.0 | 22.2 | 47.6 | 38 | 1 3/4 | 11.1 | 9.5 | 170 | 0.4 |
| 6202820UP | 6202820EN | 6202820DC | 6990820 | 24 | 45.0 | 22.2 | 47.6 | 38 | 1 3/4 | 11.1 | 9.5 | 170 | 0.3 |
| 6202825UP | 6202825EN | 6202825DC | 6990825 | 25 | 45.0 | 22.2 | 47.6 | 38 | 1 3/4 | 11.1 | 9.5 | 170 | 0.3 |
| 6202830UP | 6202830EN | 6202830DC | 6990830 | 28 | 51.0 | 25.4 | 57.2 | 46 | 2 | 12.7 | 14.3 | 225 | 0.5 |
| 6202835UP | 6202835EN | 6202835DC | 6990835 | 30 | 51.0 | 25.4 | 57.2 | 46 | 2 | 12.7 | 14.3 | 225 | 0.5 |
| 6202840UP | 6202840EN | 6202840DC | 6990840 | 32 | 51.0 | 25.4 | 57.2 | 46 | 2 | 12.7 | 14.3 | 225 | 0.5 |
| 6202845UP | 6202845EN | 6202845DC | 6990845 | 34 | 60.5 | 38.1 | 69.9 | 50 | 2 3/8 | 14.3 | 12.7 | 260 | 0.9 |
| 6202850UP | 6202850EN | 6202850DC | 6990850 | 35 | 60.5 | 38.1 | 69.9 | 50 | 2 3/8 | 14.3 | 12.7 | 260 | 0.9 |
| 6202855UP | 6202855EN | 6202855DC | 6990855 | 36 | 60.5 | 38.1 | 69.9 | 50 | 2 3/8 | 14.3 | 12.7 | 260 | 0.9 |
| 6202860UP | 6202860EN | 6202860DC | 6990860 | 38 | 60.5 | 38.1 | 69.9 | 50 | 2 3/8 | 14.3 | 12.7 | 260 | 0.8 |
| 6202865UP | 6202865EN | 6202865DC | 6990865 | 40 | 67.0 | 42.9 | 79.4 | 60 | 2 5/8 | 14.3 | 17.4 | 316 | 1.2 |
| 6202870UP | 6202870EN | 6202870DC | 6990870 | 42 | 67.0 | 42.9 | 79.4 | 60 | 2 5/8 | 14.3 | 17.4 | 316 | 1.1 |
| 6202876UP | 6202876EN | 6202876DC | 6990876 | 45 | 73.0 | 50.8 | 90.5 | 65 | 2 7/8 | 15.9 | 19.1 | 554 | 1.6 |
| 6202880UP | 6202880EN | 6202880DC | 6990880 | 48 | 73.0 | 50.8 | 90.5 | 65 | 2 7/8 | 15.9 | 19.1 | 554 | 1.6 |
| 6202885UP | 6202885EN | 6202885DC | 6990885 | 50 | 73.0 | 50.8 | 90.5 | 65 | 2 7/8 | 15.9 | 19.1 | 554 | 1.5 |
| 6202900UP | 6202900EN | 6202900DC | 6990900 | 55 | 80.0 | 54.0 | 95.3 | 70 | 3 1/8 | 15.9 | 20.7 | 600 | 1.8 |
| 6202910UP | 6202910EN | 6202910DC | 6990910 | 60 | 86.0 | 57.2 | 98.4 | 75 | 3 3/8 | 17.5 | 19.1 | 635 | 2 |
| 6202920UP | 6202920EN | 6202920DC | 6990920 | 65 | 92.0 | 60.3 | 103.2 | 82 | 3 5/8 | 17.5 | 20.7 | 680 | 2 |
| 6202930UP | 6202930EN | 6202930DC | 6990930 | 70 | 92.0 | 60.3 | 103.2 | 82 | 3 5/8 | 17.5 | 20.7 | 680 | 2 |
| 6202940UP | 6202940EN | 6202940DC | 6990940 | 75 | 100.0 | 63.5 | 108.0 | 90 | 3 7/8 | 19.1 | 20.7 | 750 | 3 |

POWER TRANSMISSION – TRANTORQUE GT

Performance Data Table

| d (mm) | M _t | T _h | P _h * |
|-----------|---------------------|----------------|---|
| | Maximum Transmitted | | Hub Pressure (N/mm ²) |
| | Torque (Nm) | Thrust (kN) | |
| 15 | 196 | 26 | 93 |
| 16 | 209 | 26 | 93 |
| 17 | 222 | 26 | 93 |
| 18 | 235 | 26 | 93 |
| 19 | 248 | 26 | 93 |
| 20 | 273 | 27 | 64 |
| 22 | 300 | 27 | 64 |
| 24 | 327 | 27 | 64 |
| 25 | 341 | 27 | 64 |
| 28 | 434 | 31 | 57 |
| 30 | 465 | 31 | 57 |
| 32 | 496 | 31 | 57 |
| 34 | 530 | 31 | 33 |
| 35 | 546 | 31 | 33 |
| 36 | 561 | 31 | 33 |
| 38 | 592 | 31 | 33 |
| 40 | 679 | 34 | 29 |
| 42 | 713 | 34 | 29 |
| 45 | 1208 | 54 | 36 |
| 48 | 1289 | 54 | 36 |
| 50 | 1343 | 54 | 36 |
| 55 | 1444 | 53 | 31 |
| 60 | 1530 | 51 | 26 |
| 65 | 1640 | 50 | 23 |
| 70 | 1766 | 50 | 23 |
| 75 | 1939 | 52 | 21 |

MULTIPLIERS

| | |
|------------------------------------|-----|
| Steel | 1.0 |
| Electroless Nickel Plated Steel | 0.6 |
| Thin Dense Chrome Coated Steel | 1.1 |
| Stainless Steel | 0.3 |

The data in the Performance Data Table is for a steel unit. To obtain data for other materials, use the multiplier provided.

For example, you require a 30mm (d) Electroless Nickel Plated Trantorque GT.

Find 30mm (d) in Performance Data Table and use the multiplier of 0.6 for Electroless Nickel Plated Steel.

$$M_t : 465 \times 0.6 = 279$$

$$T_h : 31 \times 0.6 = 19$$

$$*P_h : 57 \times 0.6 = 34$$

***IMPORTANT:**

After hub pressure (P_h) is determined, record D, L and P_h and refer to page 70 to calculate the minimum hub diameter.

Trantorque®
Mini
Inch and Metric

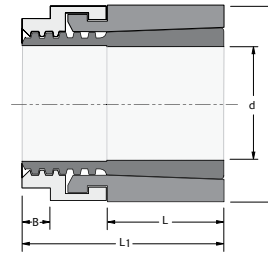
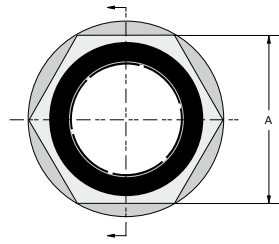

TOLERANCE (T_L)

T_L for shaft and bore is ± .0015" (.04mm) for all sizes

Trantorque Mini – Inch

| Part Number | | | | d (inch) | D (inch) | L (inch) | L ₁ (inch) | Wrench Size | | M _a † | Shipping Weight (lb) |
|-------------|---------------------------------|--------------------------------|-----------------|----------|----------|----------|-----------------------|-------------|----------|------------------|----------------------|
| Steel | Electroless Nickel Plated Steel | Thin Dense Chrome Coated Steel | Stainless Steel | | | | | A (inch) | B (inch) | | |
| 6410013 | 6202102EN | 6410013DC | 6990102 | 1/8 | 5/8 | 3/8 | 3/4 | 1/2 | 1/8 | 125 | 0.1 |
| 6410019 | 6202103EN | 6410019DC | 6990103 | 3/16 | 5/8 | 3/8 | 3/4 | 1/2 | 1/8 | 125 | 0.1 |
| 6410025 | 6202105EN | 6410025DC | 6990105 | 1/4 | 5/8 | 3/8 | 3/4 | 1/2 | 1/8 | 125 | 0.1 |
| 6410031 | 6202107EN | 6410031DC | 6990107 | 5/16 | 3/4 | 7/16 | 7/8 | 5/8 | 1/8 | 250 | 0.1 |
| 6410038 | 6202109EN | 6410038DC | 6990109 | 3/8 | 3/4 | 7/16 | 7/8 | 5/8 | 1/8 | 250 | 0.1 |
| 6410044 | 6202110EN | 6410044DC | 6990110 | 7/16 | 7/8 | 1/2 | 1 | 3/4 | 3/16 | 390 | 0.1 |
| 6410050 | 6202112EN | 6410050DC | 6990112 | 1/2 | 7/8 | 1/2 | 1 | 3/4 | 3/16 | 390 | 0.1 |
| 6410056 | 6202114EN | 6410056DC | 6990114 | 9/16 | 1 | 5/8 | 1 1/8 | 7/8 | 3/16 | 585 | 0.1 |
| 6410063 | 6202115EN | 6410063DC | 6990115 | 5/8 | 1 | 5/8 | 1 1/8 | 7/8 | 3/16 | 585 | 0.1 |

Trantorque Mini – Metric

| Part Number | | | | d (mm) | D (mm) | L (mm) | L ₁ (mm) | Wrench Size | | M _a † | Shipping Weight (kg) |
|-------------|---------------------------------|--------------------------------|-----------------|--------|--------|--------|---------------------|-------------|--------|------------------|----------------------|
| Steel | Electroless Nickel Plated Steel | Thin Dense Chrome Coated Steel | Stainless Steel | | | | | A (mm) | B (mm) | | |
| TTQM0316 | TTQM0316EN | TTQM0316DC | TTQM0316SS | 3 | 16 | 10 | 19 | 13 | 3 | 14 | 0.02 |
| TTQM0416 | TTQM0416EN | TTQM0416DC | TTQM0416SS | 4 | 16 | 10 | 19 | 13 | 3 | 14 | 0.02 |
| TTQM0516 | TTQM0516EN | TTQM0516DC | TTQM0516SS | 5 | 16 | 10 | 19 | 13 | 3 | 14 | 0.02 |
| TTQM0616 | TTQM0616EN | TTQM0616DC | TTQM0616SS | 6 | 16 | 10 | 19 | 13 | 3 | 14 | 0.02 |
| TTQM0720 | TTQM0720EN | TTQM0720DC | TTQM0720SS | 7 | 20 | 11 | 22 | 16 | 3 | 28 | 0.03 |
| TTQM0820 | TTQM0820EN | TTQM0820DC | TTQM0820SS | 8 | 20 | 11 | 22 | 16 | 3 | 28 | 0.03 |
| TTQM0920 | TTQM0920EN | TTQM0920DC | TTQM0920SS | 9 | 20 | 11 | 22 | 16 | 3 | 28 | 0.03 |
| TTQM1023 | TTQM1023EN | TTQM1023DC | TTQM1023SS | 10 | 23 | 13 | 26 | 19 | 5 | 44 | 0.05 |
| TTQM1123 | TTQM1123EN | TTQM1123DC | TTQM1123SS | 11 | 23 | 13 | 26 | 19 | 5 | 44 | 0.05 |
| TTQM1223 | TTQM1223EN | TTQM1223DC | TTQM1223SS | 12 | 23 | 13 | 26 | 19 | 5 | 44 | 0.05 |
| TTQM1426 | TTQM1426EN | TTQM1426DC | TTQM1426SS | 14 | 26 | 16 | 29 | 22 | 5 | 66 | 0.06 |
| TTQM1526 | TTQM1526EN | TTQM1526DC | TTQM1526SS | 15 | 26 | 16 | 29 | 22 | 5 | 66 | 0.06 |
| TTQM1626 | TTQM1626EN | TTQM1626DC | TTQM1626SS | 16 | 26 | 16 | 29 | 22 | 5 | 66 | 0.06 |

Performance Data Tables

| d (inch) | M _t † | Th | P _h * |
|----------|---------------------|--------------|--------------------|
| | Maximum Transmitted | | Hub Pressure (psi) |
| | Torque (in lb) | Thrust (lbs) | |
| 1/8 | 91 | 1459 | 16513 |
| 3/16 | 137 | 1459 | 16513 |
| 1/4 | 182 | 1459 | 16513 |
| 5/16 | 366 | 2345 | 18960 |
| 3/8 | 440 | 2345 | 18960 |
| 7/16 | 669 | 3057 | 18535 |
| 1/2 | 764 | 3057 | 18535 |
| 9/16 | 1110 | 3948 | 16754 |
| 5/8 | 1234 | 3948 | 16754 |

| d (mm) | M _t † | Th | P _h * |
|--------|---------------------|-------------|-----------------------------------|
| | Maximum Transmitted | | Hub Pressure (N/mm ²) |
| | Torque (Nm) | Thrust (kN) | |
| 3 | 10 | 6 | 112 |
| 4 | 13 | 6 | 112 |
| 5 | 16 | 6 | 112 |
| 6 | 19 | 6 | 112 |
| 7 | 36 | 10 | 123 |
| 8 | 41 | 10 | 123 |
| 9 | 47 | 10 | 123 |
| 10 | 68 | 14 | 123 |
| 11 | 75 | 14 | 123 |
| 12 | 81 | 14 | 123 |
| 14 | 123 | 18 | 113 |
| 15 | 132 | 18 | 113 |
| 16 | 140 | 18 | 113 |

MULTIPLIERS

| | |
|---------------------------------|------|
| Steel | 1.0 |
| Electroless Nickel Plated Steel | 0.8 |
| Thin Dense Chrome Coated Steel | 1.0 |
| Stainless Steel | 0.35 |

(continued on page 49)

Trantorque Mini Performance Data (continued from page 48)

The data in the Performance Data Table is for a steel unit. To obtain data for other materials, use the multiplier provided.

For example, you require a 1/4" (d) Electroless Nickel Plated Trantorque Mini.

Find 1/4" (d) in Performance Data Table and use the multiplier of 0.8 for Electroless Nickel Plated Steel.

$M_t: 182 \times 0.8 = 146$
 $T_H: 1459 \times 0.8 = 1167$
 $*P_h: 16513 \times 0.8 = 13210$

*IMPORTANT:

After hub pressure (P_h) is determined, record D , L and P_h and refer to page 70 to calculate the minimum hub diameter.

† When installing Trantorque Mini with an open-ended wrench, a reduction in installation torque by 50% is recommended. This will result in a Transmitted Torque (M_t) reduced by 50%.

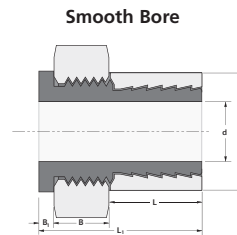
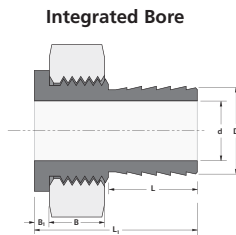
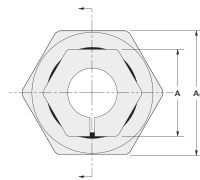

Trantorque®
Micro
 Inch and Metric

TOLERANCE (T_L)

T_L for shaft and bore is $\pm .0015"$ (.04mm) for all sizes

Trantorque Micro – Inch

| Size (inch) | d (inch) | Integrated Bore D_1 (inch) | Smooth Bore D_5 (inch) | L (inch) | L_1 (inch) | Wrench Size | | | | M_a † | Shipping Weight (lb) | M_t † | | Smooth Bore Hub Pressure (PSI) |
|-------------|----------|------------------------------|--------------------------|----------|--------------|-------------|--------------|----------|--------------|---------|----------------------|---------------------|--------------|--------------------------------|
| | | | | | | A (inch) | A_1 (inch) | B (inch) | B_1 (inch) | | | Maximum Transmitted | | |
| | | | | | | | | | | | | Torque (in lb) | Thrust (lbs) | |
| 1/8 | 0.125 | 0.369 | 0.563 | 0.38 | 0.65 | 0.44 | 0.63 | 0.20 | 0.06 | 125 | 0.032 | 53 | 846 | 9275 |
| 3/16 | 0.188 | 0.369 | 0.613 | 0.38 | 0.65 | 0.44 | 0.63 | 0.20 | 0.06 | 150 | 0.032 | 83 | 885 | 10221 |
| 1/4 | 0.250 | 0.369 | 0.613 | 0.38 | 0.69 | 0.44 | 0.63 | 0.23 | 0.06 | 150 | 0.038 | 111 | 885 | 10221 |
| 5/16 | 0.313 | 0.431 | 0.625 | 0.44 | 0.75 | 0.50 | 0.75 | 0.23 | 0.06 | 200 | 0.041 | 161 | 1028 | 7478 |
| 3/8 | 0.375 | 0.550 | 0.750 | 0.50 | 0.91 | 0.56 | 0.88 | 0.29 | 0.09 | 250 | 0.074 | 194 | 1034 | 5008 |
| 7/16 | 0.438 | 0.550 | 0.750 | 0.63 | 1.03 | 0.63 | 0.88 | 0.29 | 0.09 | 250 | 0.078 | 226 | 1034 | 5008 |
| 1/2 | 0.500 | 0.666 | 0.875 | 0.75 | 1.24 | 0.75 | 1.06 | 0.35 | 0.11 | 300 | 0.142 | 259 | 1036 | 3767 |
| 9/16 | 0.563 | 0.666 | 0.875 | 0.88 | 1.38 | 0.81 | 1.13 | 0.35 | 0.13 | 300 | 0.134 | 291 | 1036 | 3139 |
| 5/8 | 0.625 | 0.791 | 1.000 | 0.94 | 1.50 | 0.88 | 1.25 | 0.41 | 0.13 | 300 | 0.193 | 280 | 895 | 2533 |

Trantorque Micro – Metric

| Size (mm) | d (mm) | Integrated Bore D_1 (mm) | Smooth Bore D_5 (mm) | L (mm) | L_1 (mm) | Wrench Size | | | | M_a † | Shipping Weight (kg) | M_t † | | Smooth Bore Hub Pressure (PSI) |
|-----------|--------|----------------------------|------------------------|--------|------------|-------------|------------|--------|------------|---------|----------------------|---------------------|-------------|--------------------------------|
| | | | | | | A (mm) | A_1 (mm) | B (mm) | B_1 (mm) | | | Maximum Transmitted | | |
| | | | | | | | | | | | | Torque (Nm) | Thrust (kN) | |
| 3 | 3 | 9.4 | 0.563 | 9.5 | 16.6 | 11 | 16 | 5.1 | 1.5 | 14 | 0.015 | 5 | 3.2 | 9275 |
| 4 | 4 | 9.4 | 0.563 | 9.5 | 16.6 | 11 | 16 | 5.1 | 1.5 | 17 | 0.015 | 8 | 3.9 | 11130 |
| 5 | 5 | 9.4 | 0.613 | 9.5 | 16.6 | 11 | 16 | 5.1 | 1.5 | 17 | 0.017 | 10 | 3.9 | 10221 |
| 6 | 6 | 9.4 | 0.613 | 9.5 | 16.6 | 11 | 16 | 5.1 | 1.5 | 17 | 0.019 | 12 | 3.9 | 10221 |
| 7 | 7 | 10.9 | 0.613 | 9.5 | 17.4 | 13 | 19 | 5.9 | 1.5 | 17 | 0.019 | 14 | 3.9 | 8902 |
| 8 | 8 | 10.9 | 0.625 | 11.1 | 19.0 | 13 | 19 | 5.9 | 1.5 | 17 | 0.022 | 14 | 3.4 | 7478 |
| 9 | 9 | 14.0 | 0.750 | 11.1 | 20.5 | 14 | 24 | 7.5 | 2.4 | 17 | 0.023 | 15 | 3.4 | 5008 |
| 10 | 10 | 14.0 | 0.750 | 12.7 | 23.0 | 14 | 24 | 7.5 | 2.4 | 17 | 0.033 | 14 | 2.8 | 5850 |
| 11 | 11 | 14.0 | 0.750 | 12.7 | 23.0 | 14 | 24 | 7.5 | 2.4 | 23 | 0.034 | 21 | 3.7 | 5850 |
| 12 | 12 | 14.0 | 0.750 | 15.9 | 26.2 | 16 | 24 | 7.5 | 2.4 | 23 | 0.050 | 22 | 3.7 | 4680 |
| 13 | 13 | 16.9 | 0.875 | 15.9 | 27.8 | 20 | 29 | 9.0 | 2.4 | 26 | 0.110 | 22 | 3.5 | 3767 |
| 14 | 14 | 16.9 | 0.875 | 19.1 | 31.4 | 20 | 29 | 8.9 | 2.4 | 26 | 0.111 | 24 | 3.5 | 3139 |
| 15 | 15 | 16.9 | 0.875 | 19.1 | 31.4 | 20 | 29 | 8.9 | 2.8 | 26 | 0.122 | 26 | 3.5 | 3139 |
| 16 | 16 | 19.6 | 1.000 | 22.2 | 36.5 | 24 | 34 | 10.5 | 3.2 | 34 | 0.197 | 32 | 4.0 | 2533 |

*All Trantorque Micro orders are subject to a 25 piece minimum.

Trantorque®
OE
Inch

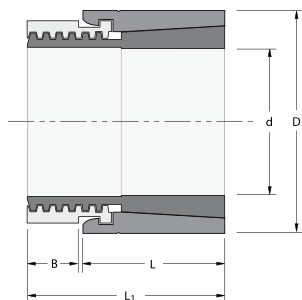
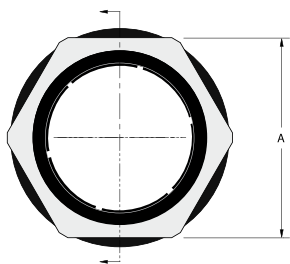

TOLERANCE (T_L)
T_L for shaft and bore is ± .003"
for all sizes

Trantorque OE – Inch

| Part Number | | | | d (inch) | D (inch) | L (inch) | L ₁ (inch) | Wrench Size | | M _a † Install Torque (ft lb) | Shipping Weight (lb) |
|-------------|---------------------------------------|---|--------------------|-------------|-------------|-------------|--------------------------|----------------|-------------|--|----------------------------|
| Steel | Electroless Nickel Plated Steel | Thin Dense Chrome Coated Steel | Stainless Steel | | | | | A (inch) | B (inch) | | |
| 6410069 | 6410069EN | 6410069DC | 6410069SS | 1 1/16 | 1 1/4 | 7/8 | 1 5/32 | 1 1/8 | 1/4 | 82 | 0.2 |
| 6410075 | 6410075EN | 6410075DC | 6410075SS | 3/4 | 1 1/4 | 7/8 | 1 5/32 | 1 1/8 | 1/4 | 82 | 0.2 |
| 6410081 | 6410081EN | 6410081DC | 6410081SS | 13/16 | 1 3/8 | 15/16 | 1 1/4 | 1 1/4 | 1/4 | 111 | 0.2 |
| 6410088 | 6410088EN | 6410088DC | 6410088SS | 7/8 | 1 3/8 | 15/16 | 1 1/4 | 1 1/4 | 1/4 | 111 | 0.2 |
| 6410094 | 6410094EN | 6410094DC | 6410094SS | 15/16 | 1 1/2 | 1 | 1 11/32 | 1 3/8 | 5/16 | 137 | 0.4 |
| 6410100 | 6410100EN | 6410100DC | 6410100SS | 1 | 1 1/2 | 1 | 1 11/32 | 1 3/8 | 5/16 | 137 | 0.3 |
| 6410106 | 6410106EN | 6410106DC | 6410106SS | 1 1/16 | 1 5/8 | 1 1/16 | 1 15/32 | 1 1/2 | 3/8 | 155 | 0.4 |
| 6410113 | 6410113EN | 6410113DC | 6410113SS | 1 1/8 | 1 5/8 | 1 1/16 | 1 15/32 | 1 1/2 | 3/8 | 155 | 0.4 |
| 6410119 | 6410119EN | 6410119DC | 6410119SS | 1 3/16 | 1 3/4 | 1 1/8 | 1 19/32 | 1 5/8 | 7/16 | 177 | 0.5 |
| 6410125 | 6410125EN | 6410125DC | 6410125SS | 1 1/4 | 1 3/4 | 1 1/8 | 1 19/32 | 1 5/8 | 7/16 | 177 | 0.5 |
| 6410131 | 6410131EN | 6410131DC | 6410131SS | 1 5/16 | 1 7/8 | 1 3/16 | 1 11/16 | 1 3/4 | 1/2 | 196 | 0.6 |
| 6410138 | 6410138EN | 6410138DC | 6410138SS | 1 3/8 | 1 7/8 | 1 3/16 | 1 11/16 | 1 3/4 | 1/2 | 196 | 0.6 |
| 6410144 | 6410144EN | 6410144DC | 6410144SS | 1 7/16 | 2 | 1 1/4 | 1 25/32 | 1 7/8 | 1/2 | 196 | 0.7 |
| 6410150 | 6410150EN | 6410150DC | 6410150SS | 1 1/2 | 2 | 1 1/4 | 1 25/32 | 1 7/8 | 1/2 | 196 | 0.6 |

Performance Data Table

| d (inch) | M _t † | T _h | P _h * Hub Pressure (psi) |
|-------------|---------------------|-----------------|--|
| | Maximum Transmitted | | Torque (ft lb) |
| | Torque (ft lb) | Thrust (lbs) | |
| 1 1/16 | 162 | 5639 | 20247 |
| 3/4 | 176 | 5639 | 20247 |
| 13/16 | 231 | 6816 | 20136 |
| 7/8 | 248 | 6816 | 20136 |
| 15/16 | 297 | 7601 | 18746 |
| 1 | 317 | 7601 | 18746 |
| 1 1/16 | 348 | 7868 | 16466 |
| 1 1/8 | 369 | 7868 | 16466 |
| 1 3/16 | 409 | 8267 | 14865 |
| 1 1/4 | 431 | 8267 | 14865 |
| 1 5/16 | 463 | 8463 | 13259 |
| 1 3/8 | 485 | 8463 | 13259 |
| 1 7/16 | 473 | 7878 | 10838 |
| 1 1/2 | 492 | 7878 | 10838 |

MULTIPLIERS

| | |
|------------------------------------|-----|
| Steel | 1.0 |
| Electroless Nickel Plated Steel | 0.6 |
| Thin Dense Chrome Coated Steel | 0.9 |
| Stainless Steel | 0.3 |

The data in the Performance Data Table is for a steel unit. To obtain data for other materials, use the multiplier provided.

For example, you require a 1" (d) Electroless Nickel Plated Trantorque OE.

Find 1" (d) in Performance Data Table and use the multiplier of 0.6 for Electroless Nickel Plated Steel.

$$M_t: 317 \times 0.6 = 190$$

$$T_h: 7601 \times 0.6 = 4561$$

$$*P_h: 18746 \times 0.6 = 11248$$

***IMPORTANT:**

After hub pressure (P_h) is determined, record D, L and P_h and refer to page 70 to calculate the minimum hub diameter.

† When installing Trantorque OE with an open-ended wrench, a reduction in installation torque by 50% is recommended. This will result in a Transmitted Torque (M_t) reduced by 50%.



TOLERANCE (T_L)

T_L for shaft and bore is ± .08mm for all sizes

Trantorque OE – Metric

| Part Number | | | | d (mm) | D (mm) | L (mm) | L ₁ (mm) | Wrench Size | B (mm) | M _a † | Shipping Weight (kg) |
|-------------|---------------------------------|--------------------------------|-----------------|--------|--------|--------|---------------------|-------------|--------|---------------------|----------------------|
| Steel | Electroless Nickel Plated Steel | Thin Dense Chrome Coated Steel | Stainless Steel | | | | | A (mm) | | Install Torque (Nm) | |
| TTQM1732 | TTQM1732EN | TTQM1732DC | TTQM1732SS | 17 | 32 | 22 | 29 | 30 | 6 | 110 | 0.1 |
| TTQM1832 | TTQM1832EN | TTQM1832DC | TTQM1832SS | 18 | 32 | 22 | 29 | 30 | 6 | 110 | 0.1 |
| TTQM1932 | TTQM1932EN | TTQM1932DC | TTQM1932SS | 19 | 32 | 22 | 29 | 30 | 6 | 110 | 0.1 |
| TTQM2035 | TTQM2035EN | TTQM2035DC | TTQM2035SS | 20 | 35 | 24 | 32 | 32 | 7 | 150 | 0.1 |
| TTQM2235 | TTQM2235EN | TTQM2235DC | TTQM2235SS | 22 | 35 | 24 | 32 | 32 | 7 | 150 | 0.1 |
| TTQM2438 | TTQM2438EN | TTQM2438DC | TTQM2438SS | 24 | 38 | 25 | 34 | 36 | 7 | 185 | 0.2 |
| TTQM2538 | TTQM2538EN | TTQM2538DC | TTQM2538SS | 25 | 38 | 25 | 34 | 36 | 7 | 185 | 0.2 |
| TTQM2845 | TTQM2845EN | TTQM2845DC | TTQM2845SS | 28 | 45 | 29 | 41 | 46 | 11 | 240 | 0.3 |
| TTQM3045 | TTQM3045EN | TTQM3045DC | TTQM3045SS | 30 | 45 | 29 | 41 | 46 | 11 | 240 | 0.3 |
| TTQM3250 | TTQM3250EN | TTQM3250DC | TTQM3250SS | 32 | 50 | 30 | 43 | 50 | 11 | 265 | 0.4 |
| TTQM3550 | TTQM3550EN | TTQM3550DC | TTQM3550SS | 35 | 50 | 30 | 43 | 50 | 11 | 265 | 0.3 |

Performance Data Table

| d (mm) | M _t † | Th | P _h * |
|--------|---------------------|-------------|-----------------------------------|
| | Maximum Transmitted | | Hub Pressure (N/mm ²) |
| | Torque (Nm) | Thrust (kN) | |
| 17 | 211 | 25 | 137 |
| 18 | 223 | 25 | 137 |
| 19 | 236 | 25 | 137 |
| 20 | 303 | 30 | 138 |
| 22 | 333 | 30 | 138 |
| 24 | 405 | 34 | 129 |
| 25 | 422 | 34 | 129 |
| 28 | 515 | 37 | 101 |
| 30 | 551 | 37 | 101 |
| 32 | 601 | 38 | 87 |
| 35 | 658 | 38 | 87 |

MULTIPLIERS

| | |
|---------------------------------|-----|
| Steel | 1.0 |
| Electroless Nickel Plated Steel | 0.6 |
| Thin Dense Chrome Coated Steel | 0.9 |
| Stainless Steel | 0.3 |

The data in the Performance Data Table is for a steel unit. To obtain data for other materials, use the multiplier provided.

For example, you require a 20mm (d) Electroless Nickel Plated Trantorque OE.

Find 20mm (d) in Performance Data Table and use the multiplier of 0.6 for Electroless Nickel Plated Steel.

$$M_t : 303 \times 0.6 = 182$$

$$T_h : 30 \times 0.6 = 18$$

$$*P_h : 138 \times 0.6 = 83$$

*** IMPORTANT:**

After hub pressure (P_h) is determined, record D, L and P_h and refer to page 70 to calculate the minimum hub diameter.

† When installing Trantorque OE with an open-ended wrench, a reduction in installation torque by 50% is recommended. This will result in a Transmitted Torque (M_t) reduced by 50%.

Trantorque®
NT
Inch

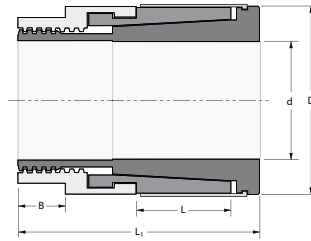
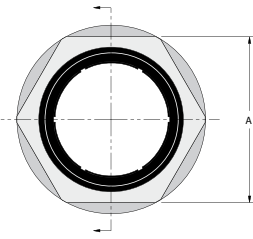

TOLERANCE (T_L)

T_L for shaft and bore is .0015" for Part Numbers 6980103UP – 6980119UP

T_L for shaft and bore is .003" for all other Trantorque NT

Trantorque NT – Inch

| Part Number | d (inch) | D (inch) | L (inch) | L ₁ (inch) | Wrench Size | | M _a Install Torque (in lb) | M _t Maximum Transmitted Torque (ft lb) | Th Thrust (lbs) | P _h * Hub Pressure (psi) |
|-------------|----------|----------|----------|-----------------------|-------------|----------|--|--|--------------------|--|
| | | | | | A (inch) | B (inch) | | | | |
| 6980103UP | 3/16 | 5/8 | 3/8 | 1 1/16 | 1/2 | 1/8 | 125 | 7 | 839 | 9496 |
| 6980105UP | 1/4 | 5/8 | 3/8 | 1 1/16 | 1/2 | 1/8 | 125 | 9 | 839 | 9496 |
| 6980107UP | 5/16 | 3/4 | 7/16 | 1 3/16 | 5/8 | 1/8 | 150 | 11 | 809 | 6542 |
| 6980109UP | 3/8 | 3/4 | 7/16 | 1 3/16 | 5/8 | 1/8 | 150 | 13 | 809 | 6542 |
| 6980110UP | 7/16 | 7/8 | 1/2 | 1 5/16 | 3/4 | 3/16 | 175 | 14 | 789 | 4783 |
| 6980112UP | 1/2 | 7/8 | 1/2 | 1 5/16 | 3/4 | 3/16 | 175 | 16 | 789 | 4783 |
| 6980114UP | 9/16 | 1 | 5/8 | 1 7/16 | 7/8 | 3/16 | 200 | 18 | 776 | 3294 |
| 6980115UP | 5/8 | 1 | 5/8 | 1 7/16 | 7/8 | 3/16 | 200 | 20 | 776 | 3294 |
| 6980119UP | 3/4 | 1 1/4 | 3/4 | 1 11/16 | 1 1/16 | 1/4 | 700 | 70 | 2227 | 6301 |
| 6980120UP | 5/8 | 1 1/2 | 11/16 | 1 13/16 | 1 1/4 | 5/16 | 1200 | 87 | 3336 | 8580 |
| 6980140UP | 11/16 | 1 1/2 | 11/16 | 1 13/16 | 1 1/4 | 5/16 | 1200 | 96 | 3336 | 8580 |
| 6980160UP | 3/4 | 1 1/2 | 11/16 | 1 13/16 | 1 1/4 | 5/16 | 1200 | 104 | 3336 | 8580 |
| 6980190UP | 13/16 | 1 3/4 | 13/16 | 2 3/16 | 1 1/2 | 7/16 | 1500 | 116 | 3441 | 6420 |
| 6980200UP | 7/8 | 1 3/4 | 13/16 | 2 3/16 | 1 1/2 | 7/16 | 1500 | 125 | 3441 | 6420 |
| 6980220UP | 15/16 | 1 3/4 | 13/16 | 2 3/16 | 1 1/2 | 7/16 | 1500 | 134 | 3441 | 6420 |
| 6980240UP | 1 | 1 3/4 | 13/16 | 2 3/16 | 1 1/2 | 7/16 | 1500 | 143 | 3441 | 6420 |
| 6980270UP | 1 1/16 | 2 | 15/16 | 2 9/16 | 1 3/4 | 1/2 | 2000 | 175 | 3962 | 5605 |
| 6980280UP | 1 1/8 | 2 | 15/16 | 2 9/16 | 1 3/4 | 1/2 | 2000 | 186 | 3962 | 5605 |
| 6980300UP | 1 3/16 | 2 | 15/16 | 2 9/16 | 1 3/4 | 1/2 | 2000 | 196 | 3962 | 5605 |
| 6980320UP | 1 1/4 | 2 | 15/16 | 2 9/16 | 1 3/4 | 1/2 | 2000 | 206 | 3962 | 5605 |
| 6980350UP | 1 5/16 | 2 3/8 | 1 7/16 | 3 3/32 | 2 | 9/16 | 2300 | 215 | 3939 | 3060 |
| 6980360UP | 1 3/8 | 2 3/8 | 1 7/16 | 3 3/32 | 2 | 9/16 | 2300 | 226 | 3939 | 3060 |
| 6980380UP | 1 7/16 | 2 3/8 | 1 7/16 | 3 3/32 | 2 | 9/16 | 2300 | 236 | 3939 | 3060 |
| 6980400UP | 1 1/2 | 2 3/8 | 1 7/16 | 3 3/32 | 2 | 9/16 | 2300 | 246 | 3939 | 3060 |
| 6980430UP | 1 9/16 | 2 5/8 | 1 5/8 | 3 15/32 | 2 1/4 | 9/16 | 2800 | 278 | 4277 | 2659 |
| 6980440UP | 1 5/8 | 2 5/8 | 1 5/8 | 3 15/32 | 2 1/4 | 9/16 | 2800 | 290 | 4277 | 2659 |
| 6980460UP | 1 11/16 | 2 5/8 | 1 5/8 | 3 15/32 | 2 1/4 | 9/16 | 2800 | 301 | 4277 | 2659 |
| 6980480UP | 1 3/4 | 2 5/8 | 1 5/8 | 3 15/32 | 2 1/4 | 9/16 | 2800 | 312 | 4277 | 2659 |
| 6980510UP | 1 13/16 | 2 7/8 | 1 15/16 | 4 3/64 | 2 1/2 | 5/8 | 4900 | 508 | 6730 | 3205 |
| 6980520UP | 1 7/8 | 2 7/8 | 1 15/16 | 4 3/64 | 2 1/2 | 5/8 | 4900 | 526 | 6730 | 3205 |
| 6980540UP | 1 15/16 | 2 7/8 | 1 15/16 | 4 3/64 | 2 1/2 | 5/8 | 4900 | 543 | 6730 | 3205 |
| 6980560UP | 2 | 2 7/8 | 1 15/16 | 4 3/64 | 2 1/2 | 5/8 | 4900 | 561 | 6730 | 3205 |

***IMPORTANT:** Please refer to page 70 to calculate your minimum hub diameter.

Consult factory for weights and availability.

B-LOC®
B109
Inch and Metric



Locking screws transfer to integrated push-off holes for disassembly.
Metric socket head locking screws ISO 4762 grade 12.9 (See M_a for install torque).
Screw head height = screw diameter (mm)

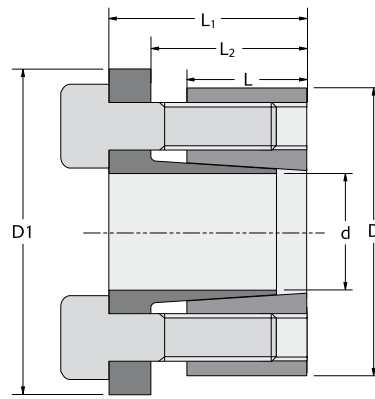

TOLERANCE (T₁)
Tolerance (T₁) for shaft and bore is ± .001" (.025mm) for all sizes.

B109 – Inch

| Part Number | d (inch) | D (inch) | D ₁ (inch) | L (inch) | L ₁ (inch) | L ₂ (inch) | Locking Screws | | M _a | M _t | Th | P _h | Shipping Weight (lb) |
|-------------|----------|----------|-----------------------|----------|-----------------------|-----------------------|----------------|---------|------------------------|---------------------|--------------|--------------------|----------------------|
| | | | | | | | Qty | Size | Install Torque (in lb) | Maximum Transmitted | | Hub Pressure (psi) | |
| | | | | | | | | | | Torque (in lb) | Thrust (lbs) | | |
| T902004 | 1/4 | 13/16 | 15/16 | 0.394 | 0.650 | 0.516 | 3 | M4 x 12 | 36.0 | 167 | 1336 | 11073 | 0.1 |
| T902005 | 5/16 | 7/8 | 1 | 0.394 | 0.650 | 0.516 | 3 | M4 x 12 | 42.5 | 246 | 1572 | 12096 | 0.1 |
| T902006 | 3/8 | 15/16 | 1 1/16 | 0.394 | 0.650 | 0.516 | 3 | M4 x 12 | 42.5 | 295 | 1572 | 11290 | 0.1 |
| B902008 | 1/2 | 1 1/16 | 1 3/16 | 0.394 | 0.650 | 0.516 | 4 | M4 x 12 | 42.5 | 524 | 2096 | 13282 | 0.1 |
| T902010 | 5/8 | 1 3/16 | 1 5/16 | 0.472 | 0.807 | 0.594 | 6 | M4 x 14 | 42.5 | 983 | 3144 | 14880 | 0.2 |
| B902012 | 3/4 | 1 5/16 | 1 7/16 | 0.472 | 0.807 | 0.594 | 6 | M4 x 14 | 42.5 | 1179 | 3144 | 13463 | 0.2 |
| T902014 | 7/8 | 1 9/16 | 1 3/4 | 0.591 | 0.984 | 0.754 | 6 | M5 x 18 | 87.0 | 2264 | 5174 | 14863 | 0.4 |
| B902100 | 1 | 1 11/16 | 1 7/8 | 0.591 | 0.984 | 0.754 | 8 | M5 x 18 | 87.0 | 3449 | 6899 | 18349 | 0.4 |
| T902102 | 1 1/8 | 1 7/8 | 2 | 0.669 | 1.102 | 0.829 | 9 | M5 x 18 | 87.0 | 4366 | 7761 | 16412 | 0.6 |
| T902103 | 1 3/16 | 1 15/16 | 2 1/16 | 0.669 | 1.102 | 0.829 | 10 | M5 x 18 | 87.0 | 5120 | 8623 | 17647 | 0.6 |
| B902104 | 1 1/4 | 2 | 2 1/8 | 0.669 | 1.102 | 0.829 | 10 | M5 x 18 | 87.0 | 5390 | 8623 | 17096 | 0.6 |
| B902106 | 1 3/8 | 2 1/8 | 2 1/4 | 0.669 | 1.102 | 0.829 | 10 | M5 x 18 | 87.0 | 5929 | 8623 | 16090 | 0.6 |

B109 – Metric

| Part Number | d (mm) | D (mm) | D ₁ (mm) | L (mm) | L ₁ (mm) | L ₂ (mm) | Locking Screws | | M _a | M _t | Th | P _h | Shipping Weight (kg) |
|-------------|--------|--------|---------------------|--------|---------------------|---------------------|----------------|---------|---------------------|---------------------|------------|-----------------------------------|----------------------|
| | | | | | | | Qty | Size | Install Torque (Nm) | Maximum Transmitted | | Hub Pressure (N/mm ²) | |
| | | | | | | | | | | Torque (Nm) | Thrust (N) | | |
| T901006 | 6 | 20.64 | 23.81 | 10 | 16.5 | 13.1 | 3 | M4 x 12 | 4.3 | 19 | 6192 | 80 | 0.05 |
| T901008 | 8 | 22.23 | 25.40 | 10 | 16.5 | 13.1 | 3 | M4 x 12 | 5 | 29 | 7285 | 87 | 0.05 |
| B901010 | 10 | 23.81 | 27.00 | 10 | 16.5 | 13.1 | 3 | M4 x 12 | 5 | 36 | 7285 | 81 | 0.05 |
| T901011 | 11 | 26.99 | 30.16 | 10 | 16.5 | 13.1 | 4 | M4 x 12 | 5 | 53 | 9713 | 95 | 0.05 |
| T901012 | 12 | 26.99 | 30.16 | 10 | 16.5 | 13.1 | 4 | M4 x 12 | 5 | 58 | 9713 | 95 | 0.05 |
| T901014 | 14 | 30.16 | 33.34 | 12 | 20.5 | 15.1 | 6 | M4 x 14 | 5 | 102 | 14569 | 107 | 0.05 |
| T901015 | 15 | 30.16 | 33.34 | 12 | 20.5 | 15.1 | 6 | M4 x 14 | 5 | 109 | 14569 | 107 | 0.09 |
| T901016 | 16 | 30.16 | 33.34 | 12 | 20.5 | 15.1 | 6 | M4 x 14 | 5 | 117 | 14569 | 107 | 0.09 |
| T901019 | 19 | 33.34 | 36.51 | 12 | 20.5 | 15.1 | 6 | M4 x 14 | 5 | 138 | 14569 | 97 | 0.09 |
| T901020 | 20 | 39.69 | 44.45 | 15 | 25 | 19.2 | 6 | M5 x 18 | 10 | 234 | 23414 | 104 | 0.18 |
| T901022 | 22 | 39.69 | 44.45 | 15 | 25 | 19.2 | 6 | M5 x 18 | 10 | 258 | 23414 | 104 | 0.18 |
| T901024 | 24 | 42.86 | 47.62 | 15 | 25 | 19.2 | 8 | M5 x 18 | 10 | 375 | 31219 | 129 | 0.18 |
| T901025 | 25 | 42.86 | 47.62 | 15 | 25 | 19.2 | 8 | M5 x 18 | 10 | 390 | 31219 | 129 | 0.18 |
| T901028 | 28 | 47.62 | 50.80 | 17 | 28 | 21.06 | 9 | M5 x 18 | 10 | 492 | 35121 | 115 | 0.27 |
| T901030 | 30 | 49.21 | 52.39 | 17 | 28 | 21.06 | 10 | M5 x 18 | 10 | 585 | 39024 | 124 | 0.27 |
| T901032 | 32 | 50.80 | 53.97 | 17 | 28 | 21.06 | 10 | M5 x 18 | 10 | 624 | 39024 | 120 | 0.27 |
| T901035 | 35 | 53.98 | 57.15 | 17 | 28 | 21.06 | 10 | M5 x 18 | 10 | 683 | 39024 | 113 | 0.27 |

POWER TRANSMISSION – B-LOC B109

B-LOC®
B103
Inch

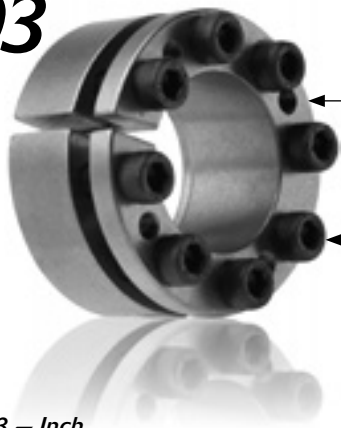

Locking screws transfer to integrated push-off holes for disassembly.

Metric socket head locking screws
ISO 4762 grade 12.9
(See M_a for install torque).

Screw head height = screw diameter (mm)

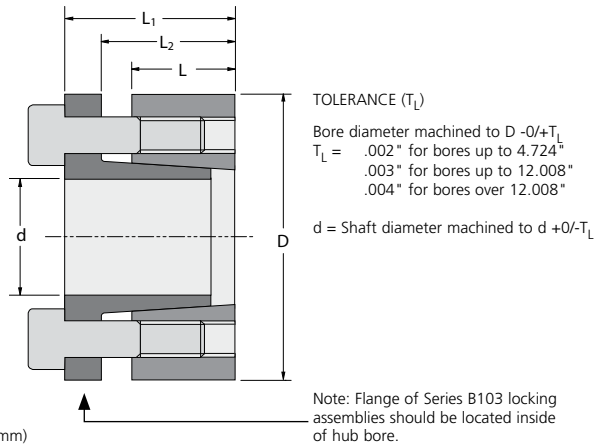

B103 – Inch

| Part Number | d (inch) | D (inch) | L (inch) | L ₁ (inch) | L ₂ (inch) | Locking Screws | | M _a Install Torque (ft lb) | M _t Maximum Transmitted | | P _h Hub Pressure (psi) | Shipping Weight (lb) |
|-------------|----------|----------|----------|-----------------------|-----------------------|----------------|----------|--|---------------------------------------|--------------|--------------------------------------|----------------------|
| | | | | | | Qty | Size | | Torque (ft lb) | Thrust (lbs) | | |
| B302012 | 3/4 | 1.850 | 0.669 | 1.122 | 0.886 | 5 | M6 x 20 | 10 | 247 | 7918 | 16959 | 0.6 |
| T302014 | 7/8 | 1.850 | 0.669 | 1.122 | 0.886 | 5 | M6 x 20 | 10 | 289 | 7918 | 16959 | 0.6 |
| B302100 | 1 | 1.969 | 0.669 | 1.122 | 0.886 | 6 | M6 x 20 | 10 | 396 | 9502 | 19130 | 0.7 |
| B302102 | 1 1/8 | 2.165 | 0.669 | 1.122 | 0.886 | 6 | M6 x 20 | 10 | 445 | 9502 | 17391 | 0.8 |
| B302103 | 1 3/16 | 2.165 | 0.669 | 1.122 | 0.886 | 6 | M6 x 20 | 10 | 470 | 9502 | 17391 | 0.7 |
| B302104 | 1 1/4 | 2.362 | 0.669 | 1.122 | 0.886 | 8 | M6 x 20 | 10 | 660 | 12669 | 21256 | 0.9 |
| B302106 | 1 3/8 | 2.362 | 0.669 | 1.122 | 0.886 | 8 | M6 x 20 | 10 | 726 | 12669 | 21256 | 0.8 |
| B302107 | 1 7/16 | 2.559 | 0.669 | 1.122 | 0.886 | 8 | M6 x 20 | 10 | 759 | 12669 | 19621 | 1.0 |
| B302108 | 1 1/2 | 2.559 | 0.669 | 1.122 | 0.886 | 8 | M6 x 20 | 10 | 792 | 12669 | 19621 | 1.0 |
| B302110 | 1 5/8 | 2.953 | 0.787 | 1.358 | 1.043 | 7 | M8 x 25 | 25 | 1439 | 21250 | 24245 | 1.7 |
| T302111 | 1 11/16 | 2.953 | 0.787 | 1.358 | 1.043 | 7 | M8 x 25 | 25 | 1494 | 21250 | 24245 | 1.6 |
| B302112 | 1 3/4 | 2.953 | 0.787 | 1.358 | 1.043 | 7 | M8 x 25 | 25 | 1550 | 21250 | 24245 | 1.6 |
| T302114 | 1 7/8 | 3.150 | 0.787 | 1.358 | 1.043 | 7 | M8 x 25 | 25 | 1660 | 21250 | 22729 | 1.8 |
| B302115 | 1 15/16 | 3.150 | 0.787 | 1.358 | 1.043 | 7 | M8 x 25 | 25 | 1716 | 21250 | 22729 | 1.7 |
| B302200 | 2 | 3.150 | 0.787 | 1.358 | 1.043 | 7 | M8 x 25 | 25 | 1771 | 21250 | 22729 | 1.6 |
| T302202 | 2 1/8 | 3.346 | 0.787 | 1.358 | 1.043 | 8 | M8 x 25 | 25 | 2150 | 24286 | 24448 | 1.9 |
| B302203 | 2 3/16 | 3.346 | 0.787 | 1.358 | 1.043 | 8 | M8 x 25 | 25 | 2214 | 24286 | 24448 | 1.8 |
| B302204 | 2 1/4 | 3.543 | 0.787 | 1.358 | 1.043 | 8 | M8 x 25 | 25 | 2277 | 24286 | 23090 | 2.1 |
| T302206 | 2 3/8 | 3.543 | 0.787 | 1.358 | 1.043 | 8 | M8 x 25 | 25 | 2403 | 24286 | 23090 | 1.9 |
| B302207 | 2 7/16 | 3.740 | 0.787 | 1.358 | 1.043 | 9 | M8 x 25 | 25 | 2775 | 27322 | 24609 | 2.2 |
| B302208 | 2 1/2 | 3.740 | 0.787 | 1.358 | 1.043 | 9 | M8 x 25 | 25 | 2846 | 27322 | 24609 | 2.2 |
| T302209 | 2 9/16 | 3.740 | 0.787 | 1.358 | 1.043 | 9 | M8 x 25 | 25 | 2917 | 27322 | 24609 | 2.1 |
| T302211 | 2 11/16 | 4.331 | 0.945 | 1.594 | 1.201 | 8 | M10 x 30 | 50 | 4411 | 39387 | 25532 | 3.8 |
| T302212 | 2 3/4 | 4.331 | 0.945 | 1.594 | 1.201 | 8 | M10 x 30 | 50 | 4513 | 39387 | 25532 | 3.7 |
| T302214 | 2 7/8 | 4.528 | 0.945 | 1.594 | 1.201 | 8 | M10 x 30 | 50 | 4718 | 39387 | 24422 | 4.0 |
| B302215 | 2 15/16 | 4.528 | 0.945 | 1.594 | 1.201 | 8 | M10 x 30 | 50 | 4821 | 39387 | 24422 | 3.9 |
| B302300 | 3 | 4.724 | 0.945 | 1.594 | 1.201 | 8 | M10 x 30 | 50 | 4923 | 39387 | 23404 | 4.4 |
| T302304 | 3 1/4 | 4.921 | 0.945 | 1.594 | 1.201 | 9 | M10 x 30 | 50 | 6000 | 44311 | 25277 | 4.5 |
| T302306 | 3 3/8 | 4.921 | 0.945 | 1.594 | 1.201 | 9 | M10 x 30 | 50 | 6231 | 44311 | 25277 | 4.3 |
| B302307 | 3 7/16 | 5.118 | 0.945 | 1.594 | 1.201 | 9 | M10 x 30 | 50 | 6347 | 44311 | 24305 | 4.8 |
| T302308 | 3 1/2 | 5.118 | 0.945 | 1.594 | 1.201 | 9 | M10 x 30 | 50 | 6462 | 44311 | 24305 | 4.6 |
| T302312 | 3 3/4 | 5.315 | 0.945 | 1.594 | 1.201 | 10 | M10 x 30 | 50 | 7693 | 49234 | 26005 | 4.7 |
| T302315 | 3 15/16 | 5.709 | 1.024 | 1.772 | 1.299 | 8 | M12 x 35 | 90 | 9944 | 60608 | 27512 | 6 |
| T302400 | 4 | 5.709 | 1.024 | 1.772 | 1.299 | 8 | M12 x 35 | 90 | 10101 | 60608 | 27512 | 6 |
| T302407 | 4 7/16 | 6.102 | 1.024 | 1.772 | 1.299 | 8 | M12 x 35 | 90 | 11206 | 60608 | 25737 | 6 |
| T302412 | 4 3/4 | 6.496 | 1.024 | 1.772 | 1.299 | 9 | M12 x 35 | 90 | 13495 | 68184 | 27200 | 7 |
| T302415 | 4 15/16 | 7.087 | 1.339 | 2.165 | 1.614 | 9 | M14 x 40 | 135 | 18113 | 88043 | 24620 | 11 |
| B302500 | 5 | 7.087 | 1.339 | 2.165 | 1.614 | 9 | M14 x 40 | 135 | 18342 | 88043 | 24620 | 11 |
| T302507 | 5 7/16 | 7.480 | 1.339 | 2.165 | 1.614 | 9 | M14 x 40 | 135 | 19947 | 88043 | 23324 | 12 |
| T302515 | 5 15/16 | 7.874 | 1.339 | 2.165 | 1.614 | 10 | M14 x 40 | 135 | 24202 | 97825 | 24620 | 12 |
| T302607 | 6 7/16 | 8.858 | 1.732 | 2.559 | 2.008 | 12 | M14 x 40 | 135 | 31488 | 117391 | 20292 | 20 |
| T302615 | 6 15/16 | 9.252 | 1.732 | 2.559 | 2.008 | 12 | M14 x 40 | 135 | 33933 | 117391 | 19429 | 20 |
| B302700 | 7 | 9.252 | 1.732 | 2.559 | 2.008 | 12 | M14 x 40 | 135 | 34239 | 117391 | 19429 | 20 |
| T302707 | 7 7/16 | 9.843 | 1.732 | 2.559 | 2.008 | 15 | M14 x 40 | 135 | 45474 | 146738 | 22829 | 22 |
| T302715 | 7 15/16 | 10.236 | 1.732 | 2.559 | 2.008 | 15 | M14 x 40 | 135 | 48531 | 146738 | 21951 | 23 |
| T302800 | 8 | 10.236 | 1.732 | 2.559 | 2.008 | 15 | M14 x 40 | 135 | 48913 | 146738 | 21951 | 21 |

TOLERANCE (T_L)

Bore diameter machined to D -0/+T_L
 T_L = .05mm for bores up to 120mm
 .08mm for bores up to 305mm
 .10mm for bores over 305mm

d = Shaft diameter machined to d +0/-T_L

B103 – Metric

| Part Number | d (mm) | D (mm) | L (mm) | L ₁ (mm) | L ₂ (mm) | Locking Screws | | M _a Install Torque (Nm) | M _t Maximum Transmitted Torque (Nm) | T _h Thrust (N) | P _h Hub Pressure (N/mm ²) | Shipping Weight (kg) |
|-------------|--------|--------|--------|---------------------|---------------------|----------------|----------|---------------------------------------|---|------------------------------|---|----------------------|
| | | | | | | Qty | Size | | | | | |
| | | | | | | | | | | | | |
| T301015 | 15 | 32 | 14 | 21.5 | 18 | 4 | M4 x 12 | 5 | 115 | 15390 | 91 | 0.1 |
| T301018 | 18 | 47 | 17 | 28.5 | 22.5 | 5 | M6 x 20 | 14 | 327 | 36371 | 121 | 0.3 |
| T301019 | 19 | 47 | 17 | 28.5 | 22.5 | 5 | M6 x 20 | 14 | 346 | 36371 | 121 | 0.3 |
| T301020 | 20 | 47 | 17 | 28.5 | 22.5 | 5 | M6 x 20 | 14 | 364 | 36371 | 121 | 0.3 |
| T301022 | 22 | 47 | 17 | 28.5 | 22.5 | 5 | M6 x 20 | 14 | 400 | 36371 | 121 | 0.2 |
| T301024 | 24 | 50 | 17 | 28.5 | 22.5 | 6 | M6 x 20 | 14 | 524 | 43645 | 136 | 0.3 |
| B301025 | 25 | 50 | 17 | 28.5 | 22.5 | 6 | M6 x 20 | 14 | 546 | 43645 | 136 | 0.3 |
| T301028 | 28 | 55 | 17 | 28.5 | 22.5 | 6 | M6 x 20 | 14 | 611 | 43645 | 124 | 0.3 |
| B301030 | 30 | 55 | 17 | 28.5 | 22.5 | 6 | M6 x 20 | 14 | 655 | 43645 | 124 | 0.3 |
| T301032 | 32 | 60 | 17 | 28.5 | 22.5 | 8 | M6 x 20 | 14 | 931 | 58193 | 151 | 0.4 |
| B301035 | 35 | 60 | 17 | 28.5 | 22.5 | 8 | M6 x 20 | 14 | 1018 | 58193 | 151 | 0.3 |
| T301038 | 38 | 65 | 17 | 28.5 | 22.5 | 8 | M6 x 20 | 14 | 1106 | 58193 | 140 | 0.4 |
| B301040 | 40 | 65 | 17 | 28.5 | 22.5 | 8 | M6 x 20 | 14 | 1164 | 58193 | 140 | 0.4 |
| T301042 | 42 | 75 | 20 | 34.5 | 26.5 | 7 | M8 x 25 | 34 | 1991 | 94822 | 168 | 0.7 |
| B301045 | 45 | 75 | 20 | 34.5 | 26.5 | 7 | M8 x 25 | 34 | 2133 | 94822 | 168 | 0.6 |
| B301050 | 50 | 80 | 20 | 34.5 | 26.5 | 7 | M8 x 25 | 34 | 2371 | 94822 | 157 | 0.7 |
| T301055 | 55 | 85 | 20 | 34.5 | 26.5 | 8 | M8 x 25 | 34 | 2980 | 108368 | 169 | 0.8 |
| B301060 | 60 | 90 | 20 | 34.5 | 26.5 | 8 | M8 x 25 | 34 | 3251 | 108368 | 160 | 0.8 |
| T301065 | 65 | 95 | 20 | 34.5 | 26.5 | 9 | M8 x 25 | 34 | 3962 | 121914 | 170 | 0.9 |
| B301070 | 70 | 110 | 24 | 40.5 | 30.5 | 8 | M10 x 30 | 68 | 6151 | 175750 | 177 | 1.6 |
| T301075 | 75 | 115 | 24 | 40.5 | 30.5 | 8 | M10 x 30 | 68 | 6591 | 175750 | 169 | 1.6 |
| T301080 | 80 | 120 | 24 | 40.5 | 30.5 | 8 | M10 x 30 | 68 | 7030 | 175750 | 162 | 1.7 |
| B301085 | 85 | 125 | 24 | 40.5 | 30.5 | 9 | M10 x 30 | 68 | 8403 | 197719 | 175 | 1.8 |
| B301090 | 90 | 130 | 24 | 40.5 | 30.5 | 9 | M10 x 30 | 68 | 8897 | 197719 | 168 | 1.9 |
| T301095 | 95 | 135 | 24 | 40.5 | 30.5 | 10 | M10 x 30 | 68 | 10435 | 219688 | 180 | 2 |
| B301100 | 100 | 145 | 26 | 45 | 33 | 8 | M12 x 35 | 122 | 13478 | 269557 | 190 | 3 |
| T301110 | 110 | 155 | 26 | 45 | 33 | 8 | M12 x 35 | 122 | 14826 | 269557 | 177 | 3 |
| B301120 | 120 | 165 | 26 | 45 | 33 | 9 | M12 x 35 | 122 | 18195 | 303251 | 188 | 3 |
| T301130 | 130 | 180 | 34 | 55 | 41 | 9 | M14 x 40 | 183 | 25452 | 391574 | 170 | 5 |
| T301140 | 140 | 190 | 34 | 55 | 41 | 9 | M14 x 40 | 183 | 27410 | 391574 | 161 | 5 |
| T301150 | 150 | 200 | 34 | 55 | 41 | 10 | M14 x 40 | 183 | 32631 | 435082 | 170 | 5 |
| T301160 | 160 | 210 | 34 | 55 | 41 | 11 | M14 x 40 | 183 | 38287 | 478591 | 178 | 6 |
| T301170 | 170 | 225 | 44 | 65 | 51 | 12 | M14 x 40 | 183 | 44378 | 522099 | 140 | 8 |
| T301180 | 180 | 235 | 44 | 65 | 51 | 12 | M14 x 40 | 183 | 46989 | 522099 | 134 | 8 |
| T301190 | 190 | 250 | 44 | 65 | 51 | 15 | M14 x 40 | 183 | 61999 | 652624 | 157 | 9 |
| T301200 | 200 | 260 | 44 | 65 | 51 | 15 | M14 x 40 | 183 | 65262 | 652624 | 151 | 10 |
| T301220 | 220 | 285 | 50 | 73 | 57 | 12 | M16 x 45 | 297 | 82145 | 746770 | 139 | 13 |
| T301240 | 240 | 305 | 50 | 73 | 57 | 15 | M16 x 45 | 297 | 112016 | 933463 | 162 | 14 |
| T301260 | 260 | 325 | 50 | 73 | 57 | 18 | M16 x 45 | 297 | 145620 | 1120155 | 183 | 15 |
| T301280 | 280 | 355 | 60 | 85 | 67 | 16 | M18 x 50 | 393 | 163726 | 1169473 | 146 | 23 |
| T301300 | 300 | 375 | 60 | 85 | 67 | 18 | M18 x 50 | 393 | 197349 | 1315657 | 155 | 24 |
| T301320 | 320 | 405 | 74 | 102 | 82 | 18 | M20 x 50 | 569 | 274346 | 1714665 | 152 | 34 |
| T301340 | 340 | 425 | 74 | 102 | 82 | 21 | M20 x 50 | 569 | 340075 | 2000443 | 169 | 36 |
| T301360 | 360 | 455 | 86 | 116 | 94 | 18 | M22 x 60 | 759 | 377769 | 2098718 | 142 | 49 |
| T301380 | 380 | 475 | 86 | 116 | 94 | 21 | M22 x 60 | 759 | 465216 | 2448505 | 159 | 52 |
| T301400 | 400 | 495 | 86 | 116 | 94 | 21 | M22 x 60 | 759 | 489701 | 2448505 | 153 | 55 |

B-LOC®
B106
Inch



Locking screws transfer to integrated push-off holes for disassembly.

Metric socket head locking screws
ISO 4762 grade 12.9
(See M_a for install torque).

Screw head height = screw diameter (mm)

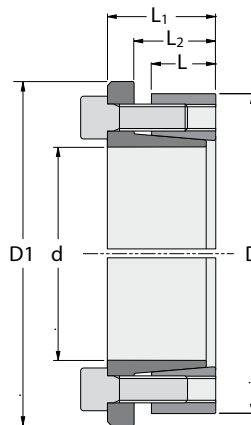

TOLERANCE (T_L)

Bore dia. machined to D -0/+T_L
T_L = .002" for bores up to 4.724"
.003" for bores up to 12.008"
.004" for bores over 12.008"

d = Shaft diameter machined to d +0/-T_L

B106 – Inch

| Part Number | d (inch) | D (inch) | D ₁ (inch) | L (inch) | L ₁ (inch) | L ₂ (inch) | Locking Screws | | M _a | M _t | T _h | P _h | Shipping Weight (lb) |
|-------------|----------|----------|-----------------------|----------|-----------------------|-----------------------|----------------|----------|----------------|----------------|--------------------|----------------|----------------------|
| | | | | | | | Qty | Size | | | | | |
| | | | | | | | | | Torque (ft lb) | Thrust (lbs) | Hub Pressure (psi) | | |
| T602010 | 5/8 | 1.260 | 1.457 | 0.551 | 0.846 | 0.709 | 4 | M4 x 12 | 3.5 | 55 | 2096 | 8007 | 0.6 |
| B602012 | 3/4 | 1.850 | 2.047 | 0.669 | 1.122 | 0.886 | 5 | M6 x 20 | 12 | 187 | 5997 | 12845 | 0.6 |
| B602014 | 7/8 | 1.850 | 2.047 | 0.669 | 1.122 | 0.886 | 5 | M6 x 20 | 12 | 219 | 5997 | 12845 | 0.7 |
| T602015 | 15/16 | 1.969 | 2.224 | 0.669 | 1.122 | 0.886 | 5 | M6 x 20 | 12 | 234 | 5997 | 12071 | 0.6 |
| B602100 | 1 | 1.969 | 2.224 | 0.669 | 1.122 | 0.886 | 6 | M6 x 20 | 12 | 300 | 7196 | 14489 | 0.7 |
| B602102 | 1 1/8 | 2.165 | 2.421 | 0.669 | 1.122 | 0.886 | 6 | M6 x 20 | 12 | 337 | 7196 | 13172 | 0.8 |
| B602103 | 1 3/16 | 2.165 | 2.421 | 0.669 | 1.122 | 0.886 | 6 | M6 x 20 | 12 | 356 | 7196 | 13172 | 0.7 |
| B602104 | 1 1/4 | 2.362 | 2.618 | 0.669 | 1.122 | 0.886 | 8 | M6 x 20 | 12 | 500 | 9595 | 16099 | 0.9 |
| B602106 | 1 3/8 | 2.362 | 2.618 | 0.669 | 1.122 | 0.886 | 8 | M6 x 20 | 12 | 550 | 9595 | 16099 | 0.8 |
| B602107 | 1 7/16 | 2.559 | 2.815 | 0.669 | 1.122 | 0.886 | 8 | M6 x 20 | 12 | 575 | 9595 | 14860 | 1.0 |
| B602108 | 1 1/2 | 2.559 | 2.815 | 0.669 | 1.122 | 0.886 | 8 | M6 x 20 | 12 | 600 | 9595 | 14860 | 1.0 |
| B602110 | 1 5/8 | 2.953 | 3.287 | 0.787 | 1.358 | 1.043 | 7 | M8 x 25 | 30 | 1090 | 16094 | 18362 | 1.7 |
| B602111 | 1 11/16 | 2.953 | 3.287 | 0.787 | 1.358 | 1.043 | 7 | M8 x 25 | 30 | 1132 | 16094 | 18362 | 1.6 |
| B602112 | 1 3/4 | 2.953 | 3.287 | 0.787 | 1.358 | 1.043 | 7 | M8 x 25 | 30 | 1174 | 16094 | 18362 | 1.6 |
| B602114 | 1 7/8 | 3.150 | 3.484 | 0.787 | 1.358 | 1.043 | 7 | M8 x 25 | 30 | 1257 | 16094 | 17214 | 1.8 |
| B602115 | 1 15/16 | 3.150 | 3.484 | 0.787 | 1.358 | 1.043 | 7 | M8 x 25 | 30 | 1299 | 16094 | 17214 | 1.7 |
| B602200 | 2 | 3.150 | 3.484 | 0.787 | 1.358 | 1.043 | 7 | M8 x 25 | 30 | 1341 | 16094 | 17214 | 1.6 |
| T602202 | 2 1/8 | 3.346 | 3.681 | 0.787 | 1.358 | 1.043 | 8 | M8 x 25 | 30 | 1629 | 18393 | 18516 | 1.9 |
| B602203 | 2 3/16 | 3.346 | 3.681 | 0.787 | 1.358 | 1.043 | 8 | M8 x 25 | 30 | 1676 | 18393 | 18516 | 1.8 |
| B602204 | 2 1/4 | 3.543 | 3.898 | 0.787 | 1.358 | 1.043 | 8 | M8 x 25 | 30 | 1724 | 18393 | 17487 | 2.1 |
| B602206 | 2 3/8 | 3.543 | 3.898 | 0.787 | 1.358 | 1.043 | 8 | M8 x 25 | 30 | 1820 | 18393 | 17487 | 1.9 |
| B602207 | 2 7/16 | 3.740 | 4.016 | 0.787 | 1.358 | 1.043 | 9 | M8 x 25 | 30 | 2102 | 20693 | 18638 | 2.2 |
| B602208 | 2 1/2 | 3.740 | 4.016 | 0.787 | 1.358 | 1.043 | 9 | M8 x 25 | 30 | 2155 | 20693 | 18638 | 2.2 |
| T602209 | 2 9/16 | 3.740 | 4.016 | 0.787 | 1.358 | 1.043 | 9 | M8 x 25 | 30 | 2209 | 20693 | 18638 | 2.1 |
| T602211 | 2 11/16 | 4.331 | 4.685 | 0.945 | 1.594 | 1.201 | 8 | M10 x 30 | 60 | 3340 | 29831 | 19337 | 3.8 |
| B602212 | 2 3/4 | 4.331 | 4.685 | 0.945 | 1.594 | 1.201 | 8 | M10 x 30 | 60 | 3418 | 29831 | 19337 | 3.7 |
| B602214 | 2 7/8 | 4.528 | 4.882 | 0.945 | 1.594 | 1.201 | 8 | M10 x 30 | 60 | 3573 | 29831 | 18496 | 4.0 |
| B602215 | 2 15/16 | 4.528 | 4.882 | 0.945 | 1.594 | 1.201 | 8 | M10 x 30 | 60 | 3651 | 29831 | 18496 | 3.9 |
| B602300 | 3 | 4.724 | 5.079 | 0.945 | 1.594 | 1.201 | 8 | M10 x 30 | 60 | 3729 | 29831 | 17726 | 4.4 |
| B602304 | 3 1/4 | 4.921 | 5.276 | 0.945 | 1.594 | 1.201 | 9 | M10 x 30 | 60 | 4545 | 33559 | 19144 | 4.5 |
| T602306 | 3 3/8 | 4.921 | 5.276 | 0.945 | 1.594 | 1.201 | 9 | M10 x 30 | 60 | 4719 | 33559 | 19144 | 4.3 |
| B602307 | 3 7/16 | 5.118 | 5.472 | 0.945 | 1.594 | 1.201 | 9 | M10 x 30 | 60 | 4807 | 33559 | 18408 | 4.8 |
| B602308 | 3 1/2 | 5.118 | 5.472 | 0.945 | 1.594 | 1.201 | 9 | M10 x 30 | 60 | 4894 | 33559 | 18408 | 4.6 |
| T602312 | 3 3/4 | 5.315 | 5.669 | 0.945 | 1.594 | 1.201 | 10 | M10 x 30 | 60 | 5826 | 37288 | 19695 | 4.7 |
| T602315 | 3 15/16 | 5.709 | 6.063 | 1.024 | 1.772 | 1.299 | 8 | M12 x 35 | 105 | 7322 | 44627 | 20258 | 6 |
| B602400 | 4 | 5.709 | 6.063 | 1.024 | 1.772 | 1.299 | 8 | M12 x 35 | 105 | 7438 | 44627 | 20258 | 6 |
| B602407 | 4 7/16 | 6.102 | 6.457 | 1.024 | 1.772 | 1.299 | 8 | M12 x 35 | 105 | 8251 | 44627 | 18951 | 6 |
| T602412 | 4 3/4 | 6.496 | 6.850 | 1.024 | 1.772 | 1.299 | 9 | M12 x 35 | 105 | 9936 | 50205 | 20028 | 7 |
| B602415 | 4 15/16 | 7.087 | 7.441 | 1.339 | 2.165 | 1.614 | 9 | M14 x 40 | 166 | 14057 | 68327 | 19106 | 11 |
| T602500 | 5 | 7.087 | 7.441 | 1.339 | 2.165 | 1.614 | 9 | M14 x 40 | 166 | 14235 | 68327 | 19106 | 11 |
| B602507 | 5 7/16 | 7.480 | 7.835 | 1.339 | 2.165 | 1.614 | 9 | M14 x 40 | 166 | 15480 | 68327 | 18101 | 12 |
| B602515 | 5 15/16 | 7.874 | 8.228 | 1.339 | 2.165 | 1.614 | 10 | M14 x 40 | 166 | 18782 | 75918 | 19106 | 12 |
| B602607 | 6 7/16 | 8.858 | 9.213 | 1.732 | 2.559 | 2.008 | 12 | M14 x 40 | 166 | 24436 | 91102 | 15748 | 20 |
| T602615 | 6 15/16 | 9.252 | 9.606 | 1.732 | 2.559 | 2.008 | 12 | M14 x 40 | 166 | 26334 | 91102 | 15078 | 20 |
| B602700 | 7 | 9.252 | 9.606 | 1.732 | 2.559 | 2.008 | 12 | M14 x 40 | 166 | 26571 | 91102 | 15078 | 20 |
| B602707 | 7 7/16 | 9.843 | 10.197 | 1.732 | 2.559 | 2.008 | 15 | M14 x 40 | 166 | 35290 | 113878 | 17717 | 22 |
| T602715 | 7 15/16 | 10.236 | 10.591 | 1.732 | 2.559 | 2.008 | 15 | M14 x 40 | 166 | 37663 | 113878 | 17035 | 23 |
| T602800 | 8 | 10.236 | 10.591 | 1.732 | 2.559 | 2.008 | 15 | M14 x 40 | 166 | 37959 | 113878 | 17035 | 21 |

TOLERANCE (T_L)

Bore diameter machined to $D -0/+T_L$
 $T_L =$.05mm for bores up to 120mm
 .08mm for bores up to 305mm
 .10mm for bores over 305mm

$d =$ Shaft diameter machined to $d +0/-T_L$

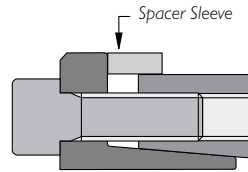

Note: Series B106 also available with optional integrated spacer sleeve (ideal for very narrow drive elements). Spacers are 0.275" wide for B106 sizes with $D=2.559"$ (65mm) and smaller, and 0.315" wide for all others.

B106 – Metric

| Part Number | d (mm) | D (mm) | D ₁ (mm) | L (mm) | L ₁ (mm) | L ₂ (mm) | Locking Screws | | M _a Install Torque (Nm) | M _t Maximum Transmitted Torque (Nm) | T _h Thrust (N) | P _h Hub Pressure (N/mm ²) | Shipping Weight (kg) |
|-------------|--------|--------|---------------------|--------|---------------------|---------------------|----------------|----------|---------------------------------------|---|------------------------------|---|----------------------|
| | | | | | | | Qty | Size | | | | | |
| | | | | | | | | | | | | | |
| T601014 | 14 | 28 | 32 | 14 | 20.5 | 17 | 4 | M4 x 12 | 5 | 68 | 9713 | 66 | 0.1 |
| T601015 | 15 | 28 | 32 | 14 | 20.5 | 17 | 4 | M4 x 12 | 5 | 73 | 9713 | 66 | 0.1 |
| T601018 | 18 | 47 | 52 | 17 | 28.5 | 22.5 | 5 | M6 x 20 | 16 | 236 | 26234 | 87 | 0.3 |
| T601019 | 19 | 47 | 52 | 17 | 28.5 | 22.5 | 5 | M6 x 20 | 16 | 249 | 26234 | 87 | 0.3 |
| T601020 | 20 | 47 | 52 | 17 | 28.5 | 22.5 | 5 | M6 x 20 | 16 | 262 | 26234 | 87 | 0.3 |
| B601022 | 22 | 47 | 52 | 17 | 28.5 | 22.5 | 5 | M6 x 20 | 16 | 289 | 26234 | 87 | 0.3 |
| T601024 | 24 | 50 | 56.5 | 17 | 28.5 | 22.5 | 6 | M6 x 20 | 16 | 378 | 31481 | 98 | 0.3 |
| B601025 | 25 | 50 | 56.5 | 17 | 28.5 | 22.5 | 6 | M6 x 20 | 16 | 394 | 31481 | 98 | 0.3 |
| B601028 | 28 | 55 | 61.5 | 17 | 28.5 | 22.5 | 6 | M6 x 20 | 16 | 441 | 31481 | 89 | 0.4 |
| B601030 | 30 | 55 | 61.5 | 17 | 28.5 | 22.5 | 6 | M6 x 20 | 16 | 472 | 31481 | 89 | 0.3 |
| T601032 | 32 | 60 | 66.5 | 17 | 28.5 | 22.5 | 8 | M6 x 20 | 16 | 672 | 41975 | 109 | 0.4 |
| B601035 | 35 | 60 | 66.5 | 17 | 28.5 | 22.5 | 8 | M6 x 20 | 16 | 735 | 41975 | 109 | 0.4 |
| T601038 | 38 | 65 | 71.5 | 17 | 28.5 | 22.5 | 8 | M6 x 20 | 16 | 798 | 41975 | 101 | 0.5 |
| B601040 | 40 | 65 | 71.5 | 17 | 28.5 | 22.5 | 8 | M6 x 20 | 16 | 839 | 41975 | 101 | 0.5 |
| T601042 | 42 | 75 | 83.5 | 20 | 34.5 | 26.5 | 7 | M8 x 25 | 41 | 1515 | 72167 | 128 | 0.8 |
| B601045 | 45 | 75 | 83.5 | 20 | 34.5 | 26.5 | 7 | M8 x 25 | 41 | 1624 | 72167 | 128 | 0.7 |
| T601048 | 48 | 80 | 88.5 | 20 | 34.5 | 26.5 | 7 | M8 x 25 | 41 | 1732 | 72167 | 120 | 0.8 |
| B601050 | 50 | 80 | 88.5 | 20 | 34.5 | 26.5 | 7 | M8 x 25 | 41 | 1804 | 72167 | 120 | 0.8 |
| B601055 | 55 | 85 | 93.5 | 20 | 34.5 | 26.5 | 8 | M8 x 25 | 41 | 2268 | 82476 | 129 | 0.8 |
| B601060 | 60 | 90 | 98 | 20 | 34.5 | 26.5 | 8 | M8 x 25 | 41 | 2474 | 82476 | 122 | 0.9 |
| T601063 | 63 | 95 | 102 | 20 | 34.5 | 26.5 | 9 | M8 x 25 | 41 | 2923 | 92786 | 130 | 0.9 |
| T601065 | 65 | 95 | 102 | 20 | 34.5 | 26.5 | 9 | M8 x 25 | 41 | 3016 | 92786 | 130 | 0.9 |
| T601070 | 70 | 110 | 119 | 24 | 40.5 | 30.5 | 8 | M10 x 30 | 81 | 4624 | 132127 | 133 | 1.7 |
| B601075 | 75 | 115 | 124 | 24 | 40.5 | 30.5 | 8 | M10 x 30 | 81 | 4955 | 132127 | 127 | 1.8 |
| B601080 | 80 | 120 | 129 | 24 | 40.5 | 30.5 | 8 | M10 x 30 | 81 | 5285 | 132127 | 122 | 1.9 |
| T601085 | 85 | 125 | 134 | 24 | 40.5 | 30.5 | 9 | M10 x 30 | 81 | 6317 | 148643 | 131 | 2 |
| B601090 | 90 | 130 | 139 | 24 | 40.5 | 30.5 | 9 | M10 x 30 | 81 | 6689 | 148643 | 126 | 2 |
| T601095 | 95 | 135 | 144 | 24 | 40.5 | 30.5 | 10 | M10 x 30 | 81 | 7845 | 165159 | 135 | 2 |
| B601100 | 100 | 145 | 154 | 26 | 45 | 33 | 8 | M12 x 35 | 142 | 9901 | 198016 | 139 | 3 |
| B601110 | 110 | 155 | 164 | 26 | 45 | 33 | 8 | M12 x 35 | 142 | 10891 | 198016 | 130 | 3 |
| B601120 | 120 | 165 | 174 | 26 | 45 | 33 | 9 | M12 x 35 | 142 | 13366 | 222768 | 138 | 3 |
| T601130 | 130 | 180 | 189 | 34 | 55 | 41 | 9 | M14 x 40 | 225 | 19751 | 303855 | 132 | 5 |
| B601140 | 140 | 190 | 199 | 34 | 55 | 41 | 9 | M14 x 40 | 225 | 21270 | 303855 | 125 | 5 |
| T601150 | 150 | 200 | 209 | 34 | 55 | 41 | 10 | M14 x 40 | 225 | 25321 | 337617 | 132 | 6 |
| B601160 | 160 | 210 | 219 | 34 | 55 | 41 | 11 | M14 x 40 | 225 | 29710 | 371379 | 138 | 6 |
| B601170 | 170 | 225 | 234 | 44 | 65 | 51 | 12 | M14 x 40 | 225 | 34437 | 405140 | 109 | 8 |
| B601180 | 180 | 235 | 244 | 44 | 65 | 51 | 12 | M14 x 40 | 225 | 36463 | 405140 | 104 | 9 |
| T601190 | 190 | 250 | 259 | 44 | 65 | 51 | 15 | M14 x 40 | 225 | 48110 | 506425 | 122 | 10 |
| B601200 | 200 | 260 | 269 | 44 | 65 | 51 | 15 | M14 x 40 | 225 | 50643 | 506425 | 117 | 10 |
| T601220 | 220 | 285 | 294 | 50 | 73 | 57 | 12 | M16 x 45 | 348 | 60747 | 552244 | 103 | 14 |
| T601240 | 240 | 305 | 314 | 50 | 73 | 57 | 15 | M16 x 45 | 348 | 82837 | 690305 | 120 | 15 |
| T601260 | 260 | 325 | 334 | 50 | 73 | 57 | 18 | M16 x 45 | 348 | 107688 | 828366 | 135 | 16 |
| T601280 | 280 | 355 | 364 | 60 | 85 | 67 | 16 | M18 x 50 | 475 | 124894 | 892098 | 111 | 23 |
| T601300 | 300 | 375 | 384 | 60 | 85 | 67 | 18 | M18 x 50 | 475 | 150542 | 1003610 | 118 | 25 |
| T601320 | 320 | 405 | 414 | 74 | 102 | 82 | 18 | M20 x 50 | 678 | 206318 | 1289490 | 114 | 35 |
| T601340 | 340 | 425 | 434 | 74 | 102 | 82 | 21 | M20 x 50 | 678 | 255749 | 1504405 | 127 | 37 |
| T601360 | 360 | 455 | 464 | 86 | 116 | 94 | 18 | M22 x 60 | 915 | 287427 | 1596815 | 108 | 51 |
| T601380 | 380 | 475 | 484 | 86 | 116 | 94 | 21 | M22 x 60 | 915 | 353961 | 1862951 | 121 | 53 |
| T601400 | 400 | 495 | 504 | 86 | 116 | 94 | 21 | M22 x 60 | 915 | 372590 | 1862951 | 116 | 57 |

B-LOC®
B800
Inch

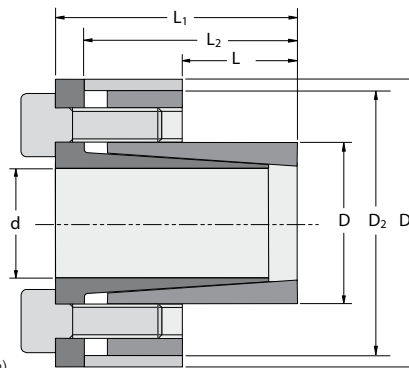
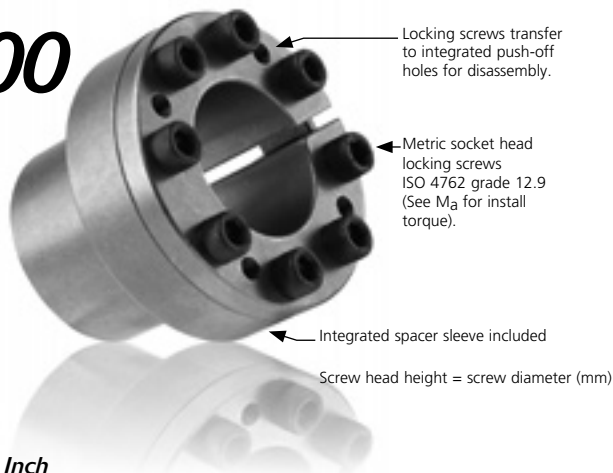

TOLERANCE (T_L)

Bore diameter machined to D -0/+T_L
T_L = .002" for bores up to 2.559"
.003" for bores over 2.559"

d = Shaft diameter machined to d +0/-T_L

B800 – Inch

| Part Number | d (inch) | D (inch) | D ₁ (inch) | D ₂ (inch) | L (inch) | L ₁ (inch) | L ₂ (inch) | Locking Screws | | M _a Install Torque (ft lb) | M _t Maximum Transmitted Torque (ft lb) | T _h Thrust (lbs) | P _h Hub Pressure (psi) | Shipping Weight (lb) |
|-------------|----------|----------|-----------------------|-----------------------|----------|-----------------------|-----------------------|---------------------|----------|--|--|--------------------------------|--------------------------------------|----------------------|
| | | | | | | | | Qty | Size | | | | | |
| | | | | | | | | Maximum Transmitted | | | | | | |
| B802004 | 1/4 | 0.551 | 0.984 | 0.906 | 0.394 | 0.866 | 0.748 | 3 | M4 x 10 | 3.5 | 16 | 1572 | 19217 | 0.2 |
| B802005 | 5/16 | 0.591 | 1.063 | 0.945 | 0.472 | 0.984 | 0.866 | 3 | M4 x 10 | 3.5 | 20 | 1572 | 14947 | 0.3 |
| B802006 | 3/8 | 0.630 | 1.142 | 1.024 | 0.551 | 1.063 | 0.945 | 4 | M4 x 10 | 3.5 | 33 | 2096 | 16014 | 0.4 |
| T82007 | 7/16 | 0.709 | 1.260 | 1.102 | 0.551 | 1.083 | 0.945 | 4 | M4 x 10 | 3.5 | 38 | 2096 | 14235 | 0.5 |
| B802008 | 1/2 | 0.906 | 1.496 | 1.299 | 0.551 | 1.083 | 0.945 | 4 | M4 x 10 | 3.5 | 44 | 2096 | 11140 | 0.5 |
| B802010 | 5/8 | 0.945 | 1.732 | 1.575 | 0.630 | 1.437 | 1.161 | 3 | M6 x 16 | 12 | 94 | 3598 | 16036 | 0.6 |
| B802012 | 3/4 | 1.063 | 1.929 | 1.693 | 0.709 | 1.555 | 1.280 | 4 | M6 x 16 | 12 | 150 | 4798 | 16893 | 0.7 |
| T82014 | 7/8 | 1.260 | 2.126 | 1.890 | 0.984 | 1.850 | 1.575 | 4 | M6 x 16 | 12 | 175 | 4798 | 10263 | 0.8 |
| B802015 | 15/16 | 1.339 | 2.205 | 1.969 | 0.984 | 1.850 | 1.575 | 6 | M6 x 16 | 12 | 281 | 7196 | 14489 | 0.9 |
| B802100 | 1 | 1.339 | 2.205 | 1.969 | 0.984 | 1.850 | 1.575 | 6 | M6 x 16 | 12 | 300 | 7196 | 14489 | 0.9 |
| B802102 | 1 1/8 | 1.535 | 2.402 | 2.165 | 0.984 | 1.850 | 1.575 | 6 | M6 x 16 | 12 | 337 | 7196 | 12631 | 1.0 |
| T82103 | 1 3/16 | 1.614 | 2.441 | 2.244 | 0.984 | 1.850 | 1.575 | 6 | M6 x 16 | 12 | 356 | 7196 | 12015 | 1.1 |
| B802104 | 1 1/4 | 1.693 | 2.559 | 2.323 | 0.984 | 1.850 | 1.575 | 8 | M6 x 16 | 12 | 500 | 9595 | 15275 | 1.2 |
| T82106 | 1 3/8 | 1.850 | 2.677 | 2.441 | 1.260 | 2.126 | 1.850 | 8 | M6 x 18 | 12 | 550 | 9595 | 10918 | 1.4 |
| B802107 | 1 7/16 | 1.969 | 2.835 | 2.598 | 1.260 | 2.126 | 1.850 | 8 | M6 x 18 | 12 | 575 | 9595 | 10263 | 1.5 |
| B802108 | 1 1/2 | 1.969 | 2.835 | 2.598 | 1.260 | 2.126 | 1.850 | 8 | M6 x 18 | 12 | 600 | 9595 | 10263 | 1.5 |
| B802110 | 1 5/8 | 2.165 | 3.071 | 2.795 | 1.260 | 2.126 | 1.850 | 8 | M6 x 18 | 12 | 650 | 9595 | 9330 | 1.7 |
| T82111 | 1 11/16 | 2.323 | 3.386 | 3.150 | 1.772 | 2.756 | 2.441 | 8 | M8 x 22 | 30 | 1293 | 18393 | 11856 | 2.7 |
| T82112 | 1 3/4 | 2.323 | 3.386 | 3.150 | 1.772 | 2.756 | 2.441 | 8 | M8 x 22 | 30 | 1341 | 18393 | 11856 | 2.7 |
| T82114 | 1 7/8 | 2.441 | 3.425 | 3.189 | 1.772 | 2.756 | 2.441 | 8 | M8 x 22 | 30 | 1437 | 18393 | 11282 | 2.7 |
| T82115 | 1 15/16 | 2.559 | 3.622 | 3.386 | 1.772 | 2.756 | 2.441 | 8 | M8 x 22 | 30 | 1485 | 18393 | 10762 | 3.1 |
| B802200 | 2 | 2.795 | 3.858 | 3.622 | 2.165 | 3.189 | 2.874 | 9 | M8 x 22 | 30 | 1724 | 20693 | 9068 | 3.8 |
| T82202 | 2 1/8 | 2.795 | 3.858 | 3.622 | 2.165 | 3.189 | 2.874 | 9 | M8 x 22 | 30 | 1832 | 20693 | 9068 | 3.8 |
| T82203 | 2 3/16 | 3.031 | 4.094 | 3.858 | 2.165 | 3.189 | 2.874 | 9 | M8 x 22 | 30 | 1886 | 20693 | 8362 | 4.2 |
| T82206 | 2 3/8 | 3.031 | 4.094 | 3.858 | 2.165 | 3.189 | 2.874 | 9 | M8 x 22 | 30 | 2048 | 20693 | 8362 | 4.2 |
| B802207 | 2 7/16 | 3.307 | 4.370 | 4.134 | 2.165 | 3.189 | 2.874 | 9 | M8 x 22 | 30 | 2102 | 20693 | 7665 | 4.9 |
| B802208 | 2 1/2 | 3.307 | 4.370 | 4.134 | 2.165 | 3.189 | 2.874 | 9 | M8 x 22 | 30 | 2155 | 20693 | 7665 | 4.9 |
| T82210 | 2 5/8 | 3.543 | 4.685 | 4.449 | 2.559 | 3.780 | 3.386 | 9 | M10 x 25 | 60 | 3671 | 33559 | 9817 | 7 |
| T82212 | 2 3/4 | 3.543 | 4.685 | 4.449 | 2.559 | 3.780 | 3.386 | 9 | M10 x 25 | 60 | 3845 | 33559 | 9817 | 7 |
| T82214 | 2 7/8 | 3.740 | 4.961 | 4.685 | 2.559 | 3.780 | 3.386 | 9 | M10 x 25 | 60 | 4020 | 33559 | 9301 | 7 |
| T82215 | 2 15/16 | 3.740 | 4.961 | 4.685 | 2.559 | 3.780 | 3.386 | 9 | M10 x 25 | 60 | 4108 | 33559 | 9301 | 7 |
| B802300 | 3 | 3.740 | 4.961 | 4.685 | 2.559 | 3.780 | 3.386 | 9 | M10 x 25 | 60 | 4195 | 33559 | 9301 | 7 |
| T82302 | 3 1/8 | 3.937 | 5.157 | 4.921 | 2.559 | 3.780 | 3.386 | 12 | M10 x 25 | 60 | 5826 | 44746 | 11781 | 8 |
| T82304 | 3 1/4 | 4.173 | 5.394 | 5.157 | 2.559 | 3.780 | 3.386 | 12 | M10 x 25 | 60 | 6059 | 44746 | 11114 | 8 |
| T82306 | 3 3/8 | 4.173 | 5.394 | 5.157 | 2.559 | 3.780 | 3.386 | 12 | M10 x 25 | 60 | 6292 | 44746 | 11114 | 8 |
| T82307 | 3 7/16 | 4.409 | 5.669 | 5.394 | 2.559 | 3.780 | 3.386 | 12 | M10 x 25 | 60 | 6409 | 44746 | 10519 | 9 |
| T82308 | 3 1/2 | 4.409 | 5.669 | 5.394 | 2.559 | 3.780 | 3.386 | 12 | M10 x 25 | 60 | 6525 | 44746 | 10519 | 9 |
| T82310 | 3 5/8 | 4.409 | 5.669 | 5.394 | 2.559 | 3.780 | 3.386 | 12 | M10 x 25 | 60 | 6758 | 44746 | 10519 | 9 |
| T82312 | 3 3/4 | 4.724 | 5.866 | 5.591 | 2.559 | 3.780 | 3.386 | 14 | M10 x 25 | 60 | 8157 | 52204 | 11454 | 10 |
| T82314 | 3 7/8 | 4.921 | 6.299 | 6.024 | 2.756 | 4.213 | 3.701 | 12 | M12 x 30 | 105 | 10808 | 66940 | 13092 | 12 |
| B802315 | 3 15/16 | 4.921 | 6.299 | 6.024 | 2.756 | 4.213 | 3.701 | 12 | M12 x 30 | 105 | 10982 | 66940 | 13092 | 12 |
| B802400 | 4 | 4.921 | 6.299 | 6.024 | 2.756 | 4.213 | 3.701 | 12 | M12 x 30 | 105 | 11157 | 66940 | 13092 | 12 |
| T82404 | 4 1/4 | 5.512 | 6.850 | 6.614 | 2.756 | 4.213 | 3.701 | 12 | M12 x 30 | 105 | 11854 | 66940 | 11690 | 15 |
| T82406 | 4 3/8 | 5.512 | 6.850 | 6.614 | 2.756 | 4.213 | 3.701 | 12 | M12 x 30 | 105 | 12203 | 66940 | 11690 | 15 |
| T82407 | 4 7/16 | 6.102 | 7.795 | 7.362 | 3.543 | 5.039 | 4.528 | 16 | M12 x 30 | 105 | 16503 | 89254 | 10949 | 21 |
| T82408 | 4 1/2 | 6.102 | 7.795 | 7.362 | 3.543 | 5.039 | 4.528 | 16 | M12 x 30 | 105 | 16735 | 89254 | 10949 | 21 |
| T82412 | 4 3/4 | 6.102 | 7.795 | 7.362 | 3.543 | 5.039 | 4.528 | 16 | M12 x 30 | 105 | 17665 | 89254 | 10949 | 21 |
| T82415 | 4 15/16 | 6.496 | 8.189 | 7.756 | 3.543 | 5.039 | 4.528 | 16 | M12 x 30 | 105 | 18362 | 89254 | 10286 | 23 |

TOLERANCE (T_L)

Bore diameter machined to D -0/+ T_L
 T_L = .05mm for bores up to 65mm
 .08mm for bores over 65mm

d = Shaft diameter machined to d +0/- T_L .

B800 – Metric

| Part Number | d (mm) | D (mm) | D ₁ (mm) | D ₂ (mm) | L (mm) | L ₁ (mm) | L ₂ (mm) | Locking Screws | | Ma | M _t | T _h | P _h | Shipping Weight (kg) |
|-------------|--------|--------|---------------------|---------------------|--------|---------------------|---------------------|----------------|----------|---------------------|---------------------|----------------|-----------------------------------|----------------------|
| | | | | | | | | Qty | Size | | | | | |
| | | | | | | | | | | Install Torque (Nm) | Maximum Transmitted | | Hub Pressure (N/mm ²) | |
| | | | | | | | | | | Torque (Nm) | Thrust (N) | | | |
| T8006 | 6 | 14 | 25 | 23 | 10 | 22 | 19 | 3 | M4 x 10 | 5 | 22 | 7285 | 138 | 0.1 |
| T8007 | 7 | 15 | 27 | 24 | 12 | 25 | 22 | 3 | M4 x 10 | 5 | 25 | 7285 | 107 | 0.1 |
| T8008 | 8 | 15 | 27 | 24 | 12 | 25 | 22 | 3 | M4 x 10 | 5 | 29 | 7285 | 107 | 0.1 |
| T8009 | 9 | 16 | 29 | 26 | 14 | 27 | 24 | 4 | M4 x 10 | 5 | 44 | 9713 | 115 | 0.1 |
| B801010 | 10 | 16 | 29 | 26 | 14 | 27 | 24 | 4 | M4 x 10 | 5 | 49 | 9713 | 115 | 0.1 |
| T8011 | 11 | 18 | 32 | 28 | 14 | 28 | 24 | 4 | M4 x 10 | 5 | 53 | 9713 | 102 | 0.1 |
| T8012 | 12 | 18 | 32 | 28 | 14 | 28 | 24 | 4 | M4 x 10 | 5 | 58 | 9713 | 102 | 0.1 |
| B801014 | 14 | 23 | 38 | 33 | 14 | 28 | 24 | 4 | M4 x 10 | 5 | 68 | 9713 | 80 | 0.1 |
| T8015 | 15 | 24 | 44 | 40 | 16 | 37 | 30 | 3 | M6 x 16 | 16 | 118 | 15740 | 109 | 0.2 |
| B801016 | 16 | 24 | 44 | 40 | 16 | 37 | 30 | 3 | M6 x 16 | 16 | 126 | 15740 | 109 | 0.2 |
| B801018 | 18 | 26 | 47 | 42 | 18 | 40 | 33 | 4 | M6 x 16 | 16 | 189 | 20987 | 119 | 0.3 |
| B801019 | 19 | 27 | 49 | 43 | 18 | 40 | 33 | 4 | M6 x 16 | 16 | 199 | 20987 | 115 | 0.3 |
| B801020 | 20 | 28 | 50 | 44 | 18 | 40 | 33 | 4 | M6 x 16 | 16 | 210 | 20987 | 110 | 0.3 |
| B801022 | 22 | 32 | 54 | 48 | 25 | 47 | 40 | 4 | M6 x 16 | 16 | 231 | 20987 | 70 | 0.4 |
| B801024 | 24 | 34 | 56 | 50 | 25 | 47 | 40 | 6 | M6 x 16 | 16 | 378 | 31481 | 98 | 0.4 |
| B801025 | 25 | 34 | 56 | 50 | 25 | 47 | 40 | 6 | M6 x 16 | 16 | 394 | 31481 | 98 | 0.4 |
| T8028 | 28 | 39 | 61 | 55 | 25 | 47 | 40 | 6 | M6 x 16 | 16 | 441 | 31481 | 86 | 0.4 |
| B801030 | 30 | 41 | 62 | 57 | 25 | 47 | 40 | 6 | M6 x 16 | 16 | 472 | 31481 | 81 | 0.4 |
| B801032 | 32 | 43 | 65 | 59 | 25 | 47 | 40 | 8 | M6 x 16 | 16 | 672 | 41975 | 104 | 0.5 |
| T8035 | 35 | 47 | 68 | 62 | 32 | 54 | 47 | 8 | M6 x 18 | 16 | 735 | 41975 | 74 | 0.5 |
| B801038 | 38 | 50 | 72 | 66 | 32 | 54 | 47 | 8 | M6 x 18 | 16 | 798 | 41975 | 70 | 0.6 |
| B801040 | 40 | 53 | 75 | 69 | 32 | 54 | 47 | 8 | M6 x 18 | 16 | 839 | 41975 | 66 | 0.7 |
| T8042 | 42 | 55 | 78 | 71 | 32 | 54 | 47 | 8 | M6 x 18 | 16 | 881 | 41975 | 63 | 0.7 |
| T8045 | 45 | 59 | 86 | 80 | 45 | 70 | 62 | 8 | M8 x 22 | 41 | 1856 | 82476 | 82 | 1.1 |
| T8048 | 48 | 62 | 87 | 81 | 45 | 70 | 62 | 8 | M8 x 22 | 41 | 1979 | 82476 | 78 | 1.1 |
| T8050 | 50 | 65 | 92 | 86 | 45 | 70 | 62 | 8 | M8 x 22 | 41 | 2062 | 82476 | 75 | 1.3 |
| T8055 | 55 | 71 | 98 | 92 | 55 | 81 | 73 | 9 | M8 x 22 | 41 | 2552 | 92786 | 63 | 1.6 |
| T8060 | 60 | 77 | 104 | 98 | 55 | 81 | 73 | 9 | M8 x 22 | 41 | 2783 | 92786 | 58 | 1.8 |
| T8065 | 65 | 84 | 111 | 105 | 55 | 81 | 73 | 9 | M8 x 22 | 41 | 3015 | 92786 | 53 | 2 |
| T8070 | 70 | 90 | 119 | 113 | 65 | 96 | 86 | 9 | M10 x 25 | 81 | 5203 | 148643 | 67 | 3 |
| T8075 | 75 | 95 | 126 | 119 | 65 | 96 | 86 | 9 | M10 x 25 | 81 | 5575 | 148643 | 64 | 3 |
| T8080 | 80 | 100 | 131 | 125 | 65 | 96 | 86 | 12 | M10 x 25 | 81 | 7928 | 198191 | 81 | 3 |
| T8085 | 85 | 106 | 137 | 131 | 65 | 96 | 86 | 12 | M10 x 25 | 81 | 8423 | 198191 | 76 | 4 |
| B801090 | 90 | 112 | 144 | 137 | 65 | 96 | 86 | 12 | M10 x 25 | 81 | 8919 | 198191 | 72 | 4 |
| T8095 | 95 | 120 | 149 | 142 | 65 | 96 | 86 | 14 | M10 x 25 | 81 | 10983 | 231223 | 79 | 4 |
| T8100 | 100 | 125 | 160 | 153 | 70 | 107 | 94 | 12 | M12 x 30 | 142 | 14851 | 297024 | 90 | 6 |
| T8110 | 110 | 140 | 174 | 168 | 70 | 107 | 94 | 12 | M12 x 30 | 142 | 16336 | 297024 | 80 | 7 |
| T8120 | 120 | 155 | 198 | 187 | 90 | 128 | 115 | 16 | M12 x 30 | 142 | 23762 | 396032 | 75 | 10 |
| T8130 | 130 | 165 | 208 | 197 | 90 | 128 | 115 | 16 | M12 x 30 | 142 | 25742 | 396032 | 71 | 11 |

B-LOC®
B400
Inch

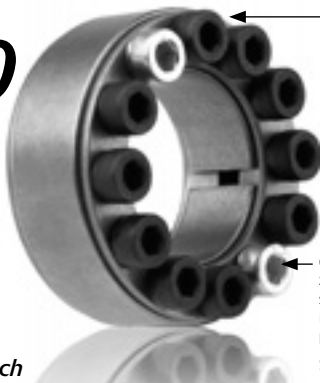

Metric socket head locking screws ISO 4762 grade 12.9 (See M_a for install torque).

(2) or (3) equally spaced zinc chromate coated screws provided solely to indicate position of partial pull out threads size d_B.

Screw head height = screw diameter (mm)

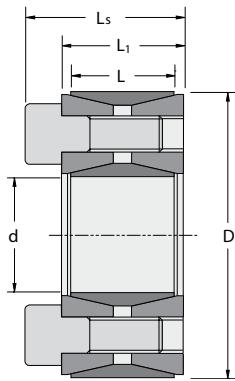

TOLERANCE (T_L)

Bore diameter machined to D -0/+T_L
T_L = .002" for bores up to 1.969"
.003" for bores up to 4.724"
.004" for bores up to 9.252"
.005" for bores up to 14.764"
.006" for bores over 14.764"

d = Shaft diameter machined to d +0/-T_L

B400 – Inch

| Part Number | d (inch) | D (inch) | L (inch) | L ₁ (inch) | L _s (inch) | Locking Screws | | M _a | d _B | Maximum Transmitted | | P _h | Shipping Weight (lb) |
|-------------|----------|----------|----------|-----------------------|-----------------------|----------------|----------|------------------------|----------------|---------------------|--------|----------------|----------------------|
| | | | | | | Qty | Size | | | M _t | Th | | |
| | | | | | | | | Install Torque (ft lb) | Torque (ft lb) | | | Thrust (lbs) | |
| B402012 | 3/4 | 1.850 | 0.669 | 0.787 | 1.024 | 8 | M6 x 18 | 11 | M8 | 234 | 7501 | 16067 | 0.5 |
| B402014 | 7/8 | 1.850 | 0.669 | 0.787 | 1.024 | 8 | M6 x 18 | 11 | M8 | 273 | 7501 | 16067 | 0.5 |
| B402100 | 1 | 1.969 | 0.669 | 0.787 | 1.024 | 9 | M6 x 18 | 11 | M8 | 352 | 8439 | 16991 | 0.5 |
| B402102 | 1 1/8 | 2.165 | 0.669 | 0.787 | 1.024 | 10 | M6 x 18 | 11 | M8 | 440 | 9377 | 17162 | 0.6 |
| T402103 | 1 3/16 | 2.159 | 0.669 | 0.787 | 1.024 | 10 | M6 x 18 | 11 | M8 | 464 | 9377 | 17212 | 0.6 |
| B402104 | 1 1/4 | 2.362 | 0.669 | 0.787 | 1.024 | 12 | M6 x 18 | 11 | M8 | 586 | 11252 | 18880 | 0.7 |
| T402106 | 1 3/8 | 2.365 | 0.669 | 0.787 | 1.024 | 12 | M6 x 18 | 11 | M8 | 645 | 11252 | 18856 | 0.6 |
| B402107 | 1 7/16 | 2.559 | 0.669 | 0.787 | 1.024 | 14 | M6 x 18 | 11 | M8 | 786 | 13127 | 20331 | 0.8 |
| B402108 | 1 1/2 | 2.559 | 0.669 | 0.787 | 1.024 | 14 | M6 x 18 | 11 | M8 | 820 | 13127 | 20331 | 0.7 |
| B402110 | 1 5/8 | 2.953 | 0.787 | 0.945 | 1.260 | 12 | M8 x 22 | 26 | M10 | 1381 | 20393 | 23267 | 1.3 |
| B402111 | 1 11/16 | 2.953 | 0.787 | 0.945 | 1.260 | 12 | M8 x 22 | 26 | M10 | 1434 | 20393 | 23267 | 1.2 |
| B402112 | 1 3/4 | 2.953 | 0.787 | 0.945 | 1.260 | 12 | M8 x 22 | 26 | M10 | 1487 | 20393 | 23267 | 1.2 |
| B402114 | 1 7/8 | 3.150 | 0.787 | 0.945 | 1.260 | 12 | M8 x 22 | 26 | M10 | 1593 | 20393 | 21812 | 1.3 |
| B402115 | 1 15/16 | 3.150 | 0.787 | 0.945 | 1.260 | 12 | M8 x 22 | 26 | M10 | 1646 | 20393 | 21812 | 1.3 |
| B402200 | 2 | 3.346 | 0.787 | 0.945 | 1.260 | 14 | M8 x 22 | 26 | M10 | 1983 | 23792 | 23951 | 1.5 |
| B402202 | 2 1/8 | 3.346 | 0.787 | 0.945 | 1.260 | 14 | M8 x 22 | 26 | M10 | 2107 | 23792 | 23951 | 1.4 |
| B402203 | 2 3/16 | 3.543 | 0.787 | 0.945 | 1.260 | 14 | M8 x 22 | 26 | M10 | 2169 | 23792 | 22622 | 1.6 |
| B402204 | 2 1/4 | 3.543 | 0.787 | 0.945 | 1.260 | 14 | M8 x 22 | 26 | M10 | 2231 | 23792 | 22620 | 1.5 |
| T402206 | 2 3/8 | 3.531 | 0.787 | 0.945 | 1.260 | 14 | M8 x 22 | 26 | M10 | 2354 | 23792 | 22699 | 1.4 |
| B402207 | 2 7/16 | 3.740 | 0.787 | 0.945 | 1.260 | 16 | M8 x 22 | 26 | M10 | 2762 | 27191 | 24491 | 1.6 |
| B402208 | 2 1/2 | 3.740 | 0.787 | 0.945 | 1.260 | 16 | M8 x 22 | 26 | M10 | 2832 | 27191 | 24491 | 1.6 |
| T402209 | 2 9/16 | 3.737 | 0.787 | 0.945 | 1.260 | 16 | M8 x 22 | 26 | M10 | 2903 | 27191 | 24512 | 1.5 |
| B402210 | 2 5/8 | 4.331 | 0.945 | 1.102 | 1.496 | 14 | M10 x 25 | 51 | M12 | 4139 | 37844 | 24532 | 2.8 |
| B402211 | 2 11/16 | 4.331 | 0.945 | 1.102 | 1.496 | 14 | M10 x 25 | 51 | M12 | 4238 | 37844 | 24532 | 2.8 |
| T402212 | 2 3/4 | 4.337 | 0.945 | 1.102 | 1.496 | 14 | M10 x 25 | 51 | M12 | 4336 | 37844 | 24496 | 2.7 |
| T402214 | 2 7/8 | 4.528 | 0.945 | 1.102 | 1.496 | 14 | M10 x 25 | 51 | M12 | 4533 | 37844 | 23465 | 2.9 |
| B402215 | 2 15/16 | 4.528 | 0.945 | 1.102 | 1.496 | 14 | M10 x 25 | 51 | M12 | 4632 | 37844 | 23465 | 2.8 |
| B402300 | 3 | 4.724 | 0.945 | 1.102 | 1.496 | 14 | M10 x 25 | 51 | M12 | 4730 | 37844 | 22487 | 3.2 |
| B402302 | 3 1/8 | 4.724 | 0.945 | 1.102 | 1.496 | 14 | M10 x 25 | 51 | M12 | 4928 | 37844 | 22487 | 3.0 |
| T402304 | 3 1/4 | 4.921 | 0.945 | 1.102 | 1.496 | 16 | M10 x 25 | 51 | M12 | 5857 | 43250 | 24672 | 3.3 |
| B402306 | 3 3/8 | 4.921 | 0.945 | 1.102 | 1.496 | 16 | M10 x 25 | 51 | M12 | 6082 | 43250 | 24672 | 3.1 |
| B402307 | 3 7/16 | 5.118 | 0.945 | 1.102 | 1.496 | 16 | M10 x 25 | 51 | M12 | 6195 | 43250 | 23723 | 3.4 |
| B402308 | 3 1/2 | 5.118 | 0.945 | 1.102 | 1.496 | 16 | M10 x 25 | 51 | M12 | 6307 | 43250 | 23723 | 3.4 |
| T402312 | 3 3/4 | 5.305 | 0.945 | 1.102 | 1.496 | 18 | M10 x 25 | 51 | M12 | 7603 | 48656 | 25748 | 3.5 |
| T402314 | 3 7/8 | 5.709 | 1.024 | 1.299 | 1.772 | 14 | M12 x 30 | 91 | M14 | 9320 | 57726 | 26204 | 4.8 |
| T402315 | 3 15/16 | 5.709 | 1.024 | 1.299 | 1.772 | 14 | M12 x 30 | 91 | M14 | 9471 | 57726 | 26204 | 4.7 |
| B402400 | 4 | 5.843 | 1.024 | 1.299 | 1.772 | 14 | M12 x 30 | 91 | M14 | 9621 | 57726 | 25602 | 5 |
| T402403 | 4 3/16 | 6.102 | 1.024 | 1.299 | 1.772 | 14 | M12 x 30 | 91 | M14 | 10072 | 57726 | 24513 | 6 |
| B402407 | 4 7/16 | 6.496 | 1.024 | 1.299 | 1.772 | 16 | M12 x 30 | 91 | M14 | 12198 | 65972 | 26317 | 6 |
| B402408 | 4 1/2 | 6.496 | 1.024 | 1.299 | 1.772 | 16 | M12 x 30 | 91 | M14 | 12370 | 65972 | 26317 | 6 |
| B402415 | 4 15/16 | 7.087 | 1.339 | 1.496 | 1.969 | 20 | M12 x 35 | 91 | M14 | 16966 | 82466 | 23060 | 8 |
| T402500 | 5 | 7.087 | 1.339 | 1.496 | 1.969 | 20 | M12 x 35 | 91 | M14 | 17180 | 82466 | 23060 | 8 |
| B402507 | 5 7/16 | 7.480 | 1.339 | 1.496 | 1.969 | 22 | M12 x 35 | 91 | M14 | 20552 | 90712 | 24031 | 9 |
| T402508 | 5 1/2 | 7.492 | 1.339 | 1.496 | 1.969 | 22 | M12 x 35 | 91 | M14 | 20788 | 90712 | 23993 | 8 |
| B402600 | 6 | 8.268 | 1.339 | 1.496 | 1.969 | 26 | M12 x 35 | 91 | M14 | 26801 | 107205 | 25695 | 10 |
| T402607 | 6 7/16 | 8.858 | 1.496 | 1.732 | 2.283 | 22 | M14 x 40 | 138 | M16 | 31764 | 118419 | 23702 | 14 |
| B402608 | 6 1/2 | 8.858 | 1.496 | 1.732 | 2.283 | 22 | M14 x 40 | 138 | M16 | 32072 | 118419 | 23702 | 13 |
| B402615 | 6 15/16 | 9.252 | 1.496 | 1.732 | 2.283 | 24 | M14 x 40 | 138 | M16 | 37343 | 129185 | 24757 | 14 |
| B402700 | 7 | 9.252 | 1.496 | 1.732 | 2.283 | 24 | M14 x 40 | 138 | M16 | 37679 | 129185 | 24757 | 14 |
| T402708 | 7 1/2 | 9.823 | 1.811 | 2.047 | 2.598 | 28 | M14 x 45 | 138 | M16 | 47099 | 150716 | 22473 | 18 |
| T402714 | 7 7/8 | 10.236 | 1.811 | 2.047 | 2.598 | 30 | M14 x 45 | 138 | M16 | 52986 | 161481 | 23106 | 19 |
| T402715 | 7 15/16 | 10.504 | 1.811 | 2.047 | 2.598 | 30 | M14 x 45 | 138 | M16 | 53407 | 161481 | 22517 | 19 |
| T402800 | 8 | 10.504 | 1.811 | 2.047 | 2.598 | 30 | M14 x 45 | 138 | M16 | 53827 | 161481 | 22517 | 19 |

TOLERANCE (T_L)

Bore diameter machined to D -0/+T_L
T_L = .05mm for bores up to 50mm
.08mm for bores up to 120mm
.10mm for bores up to 235mm
.13mm for bores up to 375mm
.15mm for bores over 375mm

d = Shaft diameter machined to d +0/-T_L

B400 – Metric

| Part Number | d (mm) | D (mm) | L (mm) | L ₁ (mm) | L ₅ (mm) | Locking Screws | | M _a | d _B | M _t | | P _h | Shipping Weight (kg) |
|-------------|--------|--------|--------|---------------------|---------------------|----------------|----------|----------------|----------------|---------------------|------------|----------------|----------------------|
| | | | | | | Qty | Size | | | Maximum Transmitted | | | |
| | | | | | | | | | | Torque (Nm) | Thrust (N) | | |
| T401018 | 18 | 47 | 17 | 20 | 26 | 8 | M6 x 18 | 15 | M8 | 302 | 33561 | 111 | 0.2 |
| T401019 | 19 | 47 | 17 | 20 | 26 | 8 | M6 x 18 | 15 | M8 | 319 | 33561 | 111 | 0.2 |
| B401020 | 20 | 47 | 17 | 20 | 26 | 8 | M6 x 18 | 15 | M8 | 335 | 33561 | 111 | 0.2 |
| T401022 | 22 | 47 | 17 | 20 | 26 | 8 | M6 x 18 | 15 | M8 | 369 | 33561 | 111 | 0.2 |
| B401024 | 24 | 50 | 17 | 20 | 26 | 9 | M6 x 18 | 15 | M8 | 453 | 37756 | 118 | 0.2 |
| B401025 | 25 | 50 | 17 | 20 | 26 | 9 | M6 x 18 | 15 | M8 | 472 | 37756 | 118 | 0.2 |
| B401028 | 28 | 55 | 17 | 20 | 26 | 10 | M6 x 18 | 15 | M8 | 587 | 41952 | 119 | 0.3 |
| B401030 | 30 | 55 | 17 | 20 | 26 | 10 | M6 x 18 | 15 | M8 | 629 | 41952 | 119 | 0.3 |
| B401032 | 32 | 60 | 17 | 20 | 26 | 12 | M6 x 18 | 15 | M8 | 806 | 50342 | 131 | 0.3 |
| B401035 | 35 | 60 | 17 | 20 | 26 | 12 | M6 x 18 | 15 | M8 | 881 | 50342 | 131 | 0.3 |
| B401038 | 38 | 65 | 17 | 20 | 26 | 14 | M6 x 18 | 15 | M8 | 1116 | 58732 | 141 | 0.3 |
| B401040 | 40 | 65 | 17 | 20 | 26 | 14 | M6 x 18 | 15 | M8 | 1175 | 58732 | 141 | 0.3 |
| B401042 | 42 | 75 | 20 | 24 | 32 | 12 | M8 x 22 | 35 | M10 | 1892 | 90071 | 159 | 0.6 |
| B401045 | 45 | 75 | 20 | 24 | 32 | 12 | M8 x 22 | 35 | M10 | 2027 | 90071 | 159 | 0.5 |
| T401048 | 48 | 80 | 20 | 24 | 32 | 12 | M8 x 22 | 35 | M10 | 2162 | 90071 | 149 | 0.6 |
| B401050 | 50 | 80 | 20 | 24 | 32 | 12 | M8 x 22 | 35 | M10 | 2252 | 90071 | 149 | 0.6 |
| B401055 | 55 | 85 | 20 | 24 | 32 | 14 | M8 x 22 | 35 | M10 | 2889 | 105083 | 164 | 0.6 |
| B401060 | 60 | 90 | 20 | 24 | 32 | 14 | M8 x 22 | 35 | M10 | 3152 | 105083 | 155 | 0.7 |
| B401065 | 65 | 95 | 20 | 24 | 32 | 16 | M8 x 22 | 35 | M10 | 3903 | 120095 | 168 | 0.7 |
| B401070 | 70 | 110 | 24 | 28 | 38 | 14 | M10 x 25 | 69 | M12 | 5880 | 167988 | 169 | 1.2 |
| B401075 | 75 | 115 | 24 | 28 | 38 | 14 | M10 x 25 | 69 | M12 | 6300 | 167988 | 161 | 1.3 |
| B401080 | 80 | 120 | 24 | 28 | 38 | 14 | M10 x 25 | 69 | M12 | 6720 | 167988 | 155 | 1.4 |
| T401085 | 85 | 125 | 24 | 28 | 38 | 16 | M10 x 25 | 69 | M12 | 8158 | 191986 | 170 | 1.4 |
| B401090 | 90 | 130 | 24 | 28 | 38 | 16 | M10 x 25 | 69 | M12 | 8639 | 191986 | 163 | 1.5 |
| B401095 | 95 | 135 | 24 | 28 | 38 | 18 | M10 x 25 | 69 | M12 | 10259 | 215984 | 177 | 1.6 |
| B401100 | 100 | 145 | 26 | 33 | 45 | 14 | M12 x 30 | 123 | M14 | 12800 | 255998 | 180 | 2 |
| B401110 | 110 | 155 | 26 | 33 | 45 | 14 | M12 x 30 | 123 | M14 | 14081 | 255998 | 169 | 2 |
| B401120 | 120 | 165 | 26 | 33 | 45 | 16 | M12 x 30 | 123 | M14 | 17553 | 292569 | 181 | 3 |
| B401130 | 130 | 180 | 34 | 38 | 50 | 20 | M12 x 35 | 123 | M14 | 23771 | 365712 | 159 | 4 |
| B401140 | 140 | 190 | 34 | 38 | 50 | 22 | M12 x 35 | 123 | M14 | 28161 | 402283 | 165 | 4 |
| T401150 | 150 | 200 | 34 | 38 | 50 | 24 | M12 x 35 | 123 | M14 | 32917 | 438854 | 171 | 4 |
| B401160 | 160 | 210 | 34 | 38 | 50 | 26 | M12 x 35 | 123 | M14 | 38033 | 475425 | 177 | 4 |
| B401170 | 170 | 225 | 38 | 44 | 58 | 22 | M14 x 40 | 187 | M16 | 44752 | 526487 | 163 | 6 |
| B401180 | 180 | 235 | 38 | 44 | 58 | 24 | M14 x 40 | 187 | M16 | 51694 | 574350 | 171 | 6 |
| B401190 | 190 | 250 | 46 | 52 | 66 | 28 | M14 x 45 | 187 | M16 | 63654 | 670075 | 155 | 8 |
| B401200 | 200 | 260 | 46 | 52 | 66 | 30 | M14 x 45 | 187 | M16 | 71794 | 717937 | 159 | 9 |
| B401220 | 220 | 285 | 50 | 56 | 72 | 26 | M16 x 50 | 290 | M20 | 93540 | 850401 | 158 | 11 |
| B401240 | 240 | 305 | 50 | 56 | 72 | 30 | M16 x 50 | 290 | M20 | 117750 | 981232 | 171 | 12 |
| B401260 | 260 | 325 | 50 | 56 | 72 | 34 | M16 x 50 | 290 | M20 | 144565 | 1112063 | 182 | 13 |
| T401280 | 280 | 355 | 60 | 66 | 84 | 32 | M18 x 60 | 397 | M22 | 178059 | 1271808 | 158 | 19 |
| T401300 | 300 | 375 | 60 | 66 | 84 | 36 | M18 x 60 | 397 | M22 | 214617 | 1430784 | 169 | 21 |
| T401320 | 320 | 405 | 72 | 78 | 98 | 36 | M20 x 70 | 569 | M24 | 295337 | 1845919 | 168 | 29 |
| T401340 | 340 | 425 | 72 | 78 | 98 | 36 | M20 x 70 | 569 | M24 | 313810 | 1845919 | 160 | 31 |
| T401360 | 360 | 455 | 84 | 90 | 112 | 36 | M22 x 80 | 766 | M27 | 410431 | 2280208 | 158 | 43 |
| T401380 | 380 | 475 | 84 | 90 | 112 | 36 | M22 x 80 | 766 | M27 | 433250 | 2280208 | 152 | 45 |
| T401400 | 400 | 495 | 84 | 90 | 112 | 36 | M22 x 80 | 766 | M27 | 456041 | 2280208 | 145 | 47 |
| T401420 | 420 | 515 | 84 | 90 | 112 | 40 | M22 x 80 | 766 | M27 | 532035 | 2533564 | 155 | 49 |
| T401440 | 440 | 545 | 96 | 102 | 126 | 40 | M24 x 90 | 983 | M30 | 651795 | 2962675 | 150 | 65 |
| T401460 | 460 | 565 | 96 | 102 | 126 | 40 | M24 x 90 | 983 | M30 | 681406 | 2962675 | 145 | 67 |
| T401480 | 480 | 585 | 96 | 102 | 126 | 42 | M24 x 90 | 983 | M30 | 746608 | 3110809 | 147 | 71 |
| T401500 | 500 | 605 | 96 | 102 | 126 | 44 | M24 x 90 | 983 | M30 | 814734 | 3258942 | 149 | 72 |

B400 – Pilot Bushings

B-LOC pilot bushings: for series B400
Keyless Bushings to provide pre-centering
in applications with either straight through
hub bores or narrow hubs. Pilot bushings
are supplied in sets consisting of three
(3) bushings and three (3) longer screws
(replacing plated locking screws). For more
information refer to www.fennerdrives.com
or contact Applications Engineering at
AE@fennerdrives.com.

Recommended pre-centering
length in installations without
pilot bushings. Provide a
minimum .001" clearance
(hub concentricity depends
on fit clearance).

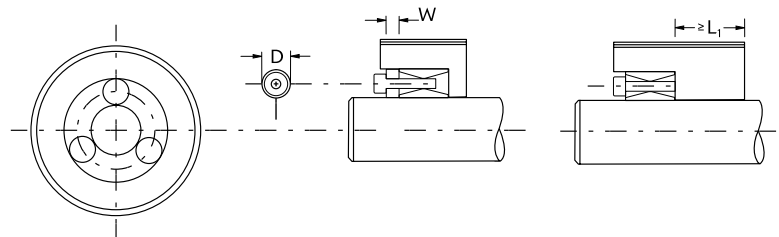

B-LOC®
B112
Inch



Locking screws transfer to integrated push-off holes for disassembly.

Metric socket head locking screws ISO 4762 grade 12.9 (See M_a for install torque).

Screw head height = screw diameter (mm)

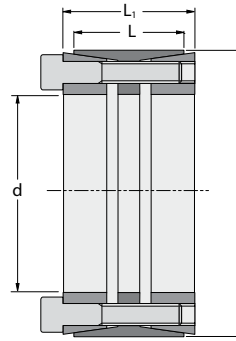

TOLERANCE (T_L)

Bore diameter machined to $D -0/+T_L$
 $T_L = .002"$ for bores up to 4.724"
 $.003"$ for bores up to 12.008"
 $.004"$ for bores up to 25.000"
 $.005"$ for bores over 25.000"

$d =$ shaft diameter machined to $d +0/-T_L$

B112 – Heavy Duty – Inch

| Part Number | d (inch) | D (inch) | L (inch) | L ₁ (inch) | Locking Screws | | M _a Install Torque (ft lb) | M _t Torque (ft lb) | Th Thrust (lbs) | P _h Hub Pressure (psi) | Shipping Weight (lb) |
|-------------|----------|----------|----------|-----------------------|----------------|-----------|--|----------------------------------|--------------------|--------------------------------------|----------------------|
| | | | | | Qty | Size | | | | | |
| | | | | | | | | | | | |
| B122100 | 1 | 2.165 | 1.260 | 1.575 | 6 | M6 x 35 | 12 | 600 | 14390 | 18656 | 1.0 |
| T122102 | 1 1/8 | 2.165 | 1.260 | 1.575 | 6 | M6 x 35 | 12 | 675 | 14390 | 18656 | 1.0 |
| B122103 | 1 3/16 | 2.165 | 1.260 | 1.575 | 6 | M6 x 35 | 12 | 712 | 14390 | 18656 | 0.9 |
| B122104 | 1 1/4 | 2.362 | 1.732 | 2.126 | 7 | M6 x 45 | 12 | 874 | 16788 | 14083 | 1.5 |
| B122106 | 1 3/8 | 2.362 | 1.732 | 2.126 | 7 | M6 x 45 | 12 | 962 | 16788 | 14083 | 1.4 |
| B122107 | 1 7/16 | 2.362 | 1.732 | 2.126 | 7 | M6 x 45 | 12 | 1006 | 16788 | 14083 | 1.3 |
| B122108 | 1 1/2 | 2.953 | 1.732 | 2.126 | 7 | M8 x 50 | 30 | 2011 | 32182 | 21598 | 2.4 |
| B122110 | 1 5/8 | 2.953 | 1.732 | 2.126 | 7 | M8 x 50 | 30 | 2179 | 32182 | 21598 | 2.3 |
| T122111 | 1 11/16 | 2.953 | 1.732 | 2.126 | 7 | M8 x 50 | 30 | 2263 | 32182 | 21598 | 2.3 |
| B122112 | 1 3/4 | 2.953 | 1.732 | 2.126 | 7 | M8 x 50 | 30 | 2347 | 32182 | 21598 | 2.1 |
| B122114 | 1 7/8 | 3.150 | 2.205 | 2.598 | 8 | M8 x 55 | 30 | 2873 | 36779 | 17881 | 2.9 |
| B122115 | 1 15/16 | 3.150 | 2.205 | 2.598 | 8 | M8 x 55 | 30 | 2969 | 36779 | 17881 | 2.8 |
| B122200 | 2 | 3.150 | 2.205 | 2.598 | 8 | M8 x 55 | 30 | 3065 | 36779 | 17881 | 2.8 |
| B122202 | 2 1/8 | 3.346 | 2.205 | 2.598 | 9 | M8 x 55 | 30 | 3664 | 41377 | 18933 | 2.9 |
| B122203 | 2 3/16 | 3.346 | 2.205 | 2.598 | 9 | M8 x 55 | 30 | 3771 | 41377 | 18933 | 2.8 |
| B122204 | 2 1/4 | 3.543 | 2.205 | 2.598 | 10 | M8 x 55 | 30 | 4310 | 45974 | 19868 | 3.3 |
| B122206 | 2 3/8 | 3.543 | 2.205 | 2.598 | 10 | M8 x 55 | 30 | 4550 | 45974 | 19868 | 3.1 |
| B122207 | 2 7/16 | 3.740 | 2.205 | 2.598 | 10 | M8 x 55 | 30 | 4669 | 45974 | 18822 | 3.6 |
| B122208 | 2 1/2 | 3.740 | 2.205 | 2.598 | 10 | M8 x 55 | 30 | 4789 | 45974 | 18822 | 3.4 |
| B122209 | 2 9/16 | 3.740 | 2.205 | 2.598 | 10 | M8 x 55 | 30 | 4909 | 45974 | 18822 | 3.3 |
| B122210 | 2 5/8 | 4.331 | 2.756 | 3.150 | 10 | M10 x 60 | 60 | 8155 | 74561 | 20714 | 7 |
| T122211 | 2 11/16 | 4.331 | 2.756 | 3.150 | 10 | M10 x 60 | 60 | 8349 | 74561 | 20714 | 7 |
| B122212 | 2 3/4 | 4.331 | 2.756 | 3.150 | 10 | M10 x 60 | 60 | 8543 | 74561 | 20714 | 6 |
| B122214 | 2 7/8 | 4.331 | 2.756 | 3.150 | 10 | M10 x 60 | 60 | 8932 | 74561 | 20714 | 6 |
| B122215 | 2 15/16 | 4.724 | 2.756 | 3.150 | 11 | M10 x 60 | 60 | 10039 | 82017 | 20887 | 8 |
| B122300 | 3 | 4.724 | 2.756 | 3.150 | 11 | M10 x 60 | 60 | 10252 | 82017 | 20887 | 7 |
| T122302 | 3 1/8 | 4.724 | 2.756 | 3.150 | 11 | M10 x 60 | 60 | 10679 | 82017 | 20887 | 7 |
| B122304 | 3 1/4 | 4.724 | 2.756 | 3.150 | 11 | M10 x 60 | 60 | 11107 | 82017 | 20887 | 7 |
| B122306 | 3 3/8 | 5.118 | 2.756 | 3.150 | 12 | M10 x 60 | 60 | 12582 | 89474 | 21033 | 8 |
| B122307 | 3 7/16 | 5.118 | 2.756 | 3.150 | 12 | M10 x 60 | 60 | 12815 | 89474 | 21033 | 8 |
| B122308 | 3 1/2 | 5.118 | 2.756 | 3.150 | 12 | M10 x 60 | 60 | 13048 | 89474 | 21033 | 8 |
| T122310 | 3 5/8 | 5.118 | 2.756 | 3.150 | 12 | M10 x 60 | 60 | 13514 | 89474 | 21033 | 7 |
| B122312 | 3 3/4 | 5.709 | 3.543 | 4.016 | 11 | M12 x 80 | 105 | 19172 | 122699 | 20688 | 13 |
| B122314 | 3 7/8 | 5.709 | 3.543 | 4.016 | 11 | M12 x 80 | 105 | 19811 | 122699 | 20688 | 12 |
| T122315 | 3 15/16 | 5.709 | 3.543 | 4.016 | 11 | M12 x 80 | 105 | 20130 | 122699 | 20688 | 13 |
| B122400 | 4 | 5.709 | 3.543 | 4.016 | 11 | M12 x 80 | 105 | 20450 | 122699 | 20688 | 12 |
| T122404 | 4 1/4 | 6.102 | 3.543 | 4.016 | 12 | M12 x 80 | 105 | 23703 | 133853 | 21112 | 14 |
| T122406 | 4 3/8 | 6.102 | 3.543 | 4.016 | 12 | M12 x 80 | 105 | 24400 | 133853 | 21112 | 13 |
| B122407 | 4 7/16 | 6.496 | 3.543 | 4.016 | 14 | M12 x 80 | 105 | 28874 | 156162 | 23138 | 16 |
| B122408 | 4 1/2 | 6.496 | 3.543 | 4.016 | 14 | M12 x 80 | 105 | 29280 | 156162 | 23138 | 16 |
| T122412 | 4 3/4 | 6.496 | 3.543 | 4.016 | 14 | M12 x 80 | 105 | 30907 | 156162 | 23138 | 14 |
| B122415 | 4 15/16 | 7.087 | 4.094 | 4.567 | 12 | M14 x 90 | 166 | 37477 | 182167 | 20618 | 21 |
| B122500 | 5 | 7.087 | 4.094 | 4.567 | 12 | M14 x 90 | 166 | 37952 | 182167 | 20618 | 21 |
| B122504 | 5 1/4 | 7.480 | 4.094 | 4.567 | 14 | M14 x 90 | 166 | 46491 | 212528 | 22789 | 24 |
| B122507 | 5 7/16 | 7.480 | 4.094 | 4.567 | 14 | M14 x 90 | 166 | 48151 | 212528 | 22789 | 22 |
| T122508 | 5 1/2 | 7.480 | 4.094 | 4.567 | 14 | M14 x 90 | 166 | 48704 | 212528 | 22789 | 21 |
| T122512 | 5 3/4 | 7.874 | 4.094 | 4.567 | 15 | M14 x 90 | 166 | 54555 | 227709 | 23196 | 24 |
| B122515 | 5 15/16 | 7.874 | 4.094 | 4.567 | 15 | M14 x 90 | 166 | 56334 | 227709 | 23196 | 22 |
| B122600 | 6 | 8.268 | 4.094 | 4.567 | 16 | M14 x 90 | 166 | 60722 | 242890 | 23564 | 26 |
| T122607 | 6 7/16 | 8.858 | 5.276 | 5.866 | 14 | M16 x 110 | 257 | 77782 | 289982 | 20051 | 40 |
| T122608 | 6 1/2 | 8.858 | 5.276 | 5.866 | 14 | M16 x 110 | 257 | 78537 | 289982 | 20051 | 39 |
| B122615 | 6 15/16 | 9.252 | 5.276 | 5.866 | 15 | M16 x 110 | 257 | 89810 | 310695 | 20569 | 40 |
| B122700 | 7 | 9.252 | 5.276 | 5.866 | 15 | M16 x 110 | 257 | 90619 | 310695 | 20569 | 38 |
| T122704 | 7 1/4 | 9.843 | 5.276 | 5.866 | 16 | M16 x 110 | 257 | 100113 | 331408 | 20624 | 47 |
| T122707 | 7 7/16 | 9.843 | 5.276 | 5.866 | 16 | M16 x 110 | 257 | 102702 | 331408 | 20624 | 44 |
| T122708 | 7 1/2 | 9.843 | 5.276 | 5.866 | 16 | M16 x 110 | 257 | 103565 | 331408 | 20624 | 43 |
| T122712 | 7 3/4 | 10.236 | 5.276 | 5.866 | 16 | M16 x 110 | 257 | 107017 | 331408 | 19830 | 48 |
| T122715 | 7 15/16 | 10.236 | 5.276 | 5.866 | 16 | M16 x 110 | 257 | 109606 | 331408 | 19830 | 45 |
| T122800 | 8 | 10.236 | 5.276 | 5.866 | 16 | M16 x 110 | 257 | 110469 | 331408 | 19830 | 44 |

TOLERANCE (T_L)

Bore diameter machined to D -0/+T_L
 T_L = .05mm for bores up to 120mm
 .08mm for bores up to 305mm
 .10mm for bores up to 635mm
 .13mm for bores over 635mm

d = shaft diameter machined to d +0/-T_L.

B112 – Heavy Duty – Metric

| Part Number | d (mm) | D (mm) | L (mm) | L ₁ (mm) | Locking Screws | | M _a Install Torque (Nm) | M _t Maximum Transmitted Torque (Nm) | T _h Thrust (N) | P _h Hub Pressure (N/mm ²) | Shipping Weight (kg) |
|-------------|--------|--------|--------|---------------------|----------------|-----------|---------------------------------------|---|------------------------------|---|----------------------|
| | | | | | Qty | Size | | | | | |
| | | | | | T121024 | 24 | 55 | 32 | 40 | 6 | |
| B121025 | 25 | 55 | 32 | 40 | 6 | M6 x 35 | 16 | 787 | 62949 | 126 | 0.4 |
| T121028 | 28 | 55 | 32 | 40 | 6 | M6 x 35 | 16 | 881 | 62949 | 126 | 0.4 |
| B121030 | 30 | 55 | 32 | 40 | 6 | M6 x 35 | 16 | 944 | 62949 | 126 | 0.4 |
| T121032 | 32 | 60 | 44 | 54 | 7 | M6 x 45 | 16 | 1175 | 73440 | 95 | 0.6 |
| B121035 | 35 | 60 | 44 | 54 | 7 | M6 x 45 | 16 | 1285 | 73440 | 95 | 0.6 |
| T121038 | 38 | 75 | 44 | 54 | 7 | M8 x 50 | 41 | 2742 | 144304 | 150 | 1.0 |
| B121040 | 40 | 75 | 44 | 54 | 7 | M8 x 50 | 41 | 2886 | 144304 | 150 | 1.0 |
| T121042 | 42 | 75 | 44 | 54 | 7 | M8 x 50 | 41 | 3030 | 144304 | 150 | 1.0 |
| B121045 | 45 | 75 | 44 | 54 | 7 | M8 x 50 | 41 | 3247 | 144304 | 150 | 0.9 |
| T121048 | 48 | 80 | 56 | 66 | 8 | M8 x 55 | 41 | 3958 | 164918 | 124 | 1.3 |
| B121050 | 50 | 80 | 56 | 66 | 8 | M8 x 55 | 41 | 4123 | 164918 | 124 | 1.2 |
| B121055 | 55 | 85 | 56 | 66 | 9 | M8 x 55 | 41 | 5102 | 185533 | 132 | 1.3 |
| B121060 | 60 | 90 | 56 | 66 | 10 | M8 x 55 | 41 | 6184 | 206148 | 138 | 1.4 |
| B121065 | 65 | 95 | 56 | 66 | 10 | M8 x 55 | 41 | 6700 | 206148 | 131 | 1.5 |
| B121070 | 70 | 110 | 70 | 80 | 10 | M10 x 60 | 81 | 11559 | 330251 | 142 | 3 |
| T121075 | 75 | 115 | 70 | 80 | 10 | M10 x 60 | 81 | 12384 | 330251 | 136 | 3 |
| B121080 | 80 | 120 | 70 | 80 | 11 | M10 x 60 | 81 | 14531 | 363276 | 143 | 3 |
| T121085 | 85 | 125 | 70 | 80 | 11 | M10 x 60 | 81 | 15439 | 363276 | 138 | 3 |
| B121090 | 90 | 130 | 70 | 80 | 12 | M10 x 60 | 81 | 17834 | 396302 | 144 | 4 |
| T121095 | 95 | 135 | 70 | 80 | 12 | M10 x 60 | 81 | 18824 | 396302 | 139 | 4 |
| B121100 | 100 | 145 | 90 | 102 | 11 | M12 x 80 | 142 | 27222 | 544433 | 142 | 6 |
| B121110 | 110 | 155 | 90 | 102 | 12 | M12 x 80 | 142 | 32666 | 593927 | 145 | 6 |
| B121120 | 120 | 165 | 90 | 102 | 14 | M12 x 80 | 142 | 41575 | 692914 | 159 | 7 |
| B121130 | 130 | 180 | 104 | 116 | 12 | M14 x 90 | 225 | 52658 | 810116 | 142 | 9 |
| B121140 | 140 | 190 | 104 | 116 | 14 | M14 x 90 | 225 | 66159 | 945135 | 157 | 10 |
| B121150 | 150 | 200 | 104 | 116 | 15 | M14 x 90 | 225 | 75948 | 1012645 | 160 | 10 |
| B121160 | 160 | 210 | 104 | 116 | 16 | M14 x 90 | 225 | 86412 | 1080154 | 162 | 11 |
| T121170 | 170 | 225 | 134 | 149 | 14 | M16 x 110 | 348 | 109506 | 1288307 | 138 | 16 |
| T121180 | 180 | 235 | 134 | 149 | 15 | M16 x 110 | 348 | 124230 | 1380329 | 142 | 17 |
| T121190 | 190 | 250 | 134 | 149 | 16 | M16 x 110 | 348 | 139873 | 1472351 | 142 | 20 |
| B121200 | 200 | 260 | 134 | 149 | 16 | M16 x 110 | 348 | 147235 | 1472351 | 137 | 21 |
| B121220 | 220 | 285 | 134 | 150 | 18 | M16 x 110 | 348 | 182203 | 1656395 | 140 | 25 |
| B121240 | 240 | 305 | 134 | 150 | 20 | M16 x 110 | 348 | 220853 | 1840439 | 146 | 27 |
| T121260 | 260 | 325 | 134 | 150 | 21 | M16 x 110 | 348 | 251220 | 1932460 | 143 | 29 |
| T121280 | 280 | 355 | 165 | 177 | 18 | M20 x 130 | 678 | 360984 | 2578456 | 146 | 43 |
| T121300 | 300 | 375 | 165 | 177 | 20 | M20 x 130 | 678 | 429743 | 2864951 | 154 | 47 |
| T121320 | 320 | 405 | 165 | 177 | 21 | M20 x 130 | 678 | 481312 | 3008198 | 149 | 56 |
| T121340 | 340 | 425 | 165 | 177 | 22 | M20 x 130 | 678 | 535746 | 3151446 | 149 | 60 |
| T121360 | 360 | 455 | 190 | 203 | 21 | M22 x 150 | 915 | 670526 | 3725144 | 143 | 80 |
| T121380 | 380 | 475 | 190 | 203 | 22 | M22 x 150 | 915 | 741481 | 3902532 | 143 | 85 |
| T121400 | 400 | 495 | 190 | 203 | 24 | M22 x 150 | 915 | 851462 | 4257308 | 150 | 88 |
| T121420 | 420 | 515 | 190 | 203 | 24 | M22 x 150 | 915 | 894035 | 4257308 | 144 | 92 |
| T121440 | 440 | 535 | 190 | 203 | 24 | M22 x 150 | 915 | 936608 | 4257308 | 139 | 96 |
| T121460 | 460 | 555 | 190 | 203 | 24 | M22 x 150 | 915 | 979181 | 4257308 | 134 | 101 |
| T121480 | 480 | 575 | 190 | 203 | 28 | M22 x 150 | 915 | 1192046 | 4966859 | 151 | 103 |
| T121500 | 500 | 595 | 190 | 203 | 28 | M22 x 150 | 915 | 1241715 | 4966859 | 146 | 108 |
| T121520 | 520 | 615 | 190 | 203 | 30 | M22 x 150 | 915 | 1383625 | 5321634 | 151 | 111 |
| T121540 | 540 | 635 | 190 | 203 | 30 | M22 x 150 | 915 | 1436841 | 5321634 | 146 | 114 |
| T121560 | 560 | 655 | 190 | 203 | 32 | M22 x 150 | 915 | 1589395 | 5676410 | 151 | 119 |
| T121580 | 580 | 675 | 190 | 203 | 32 | M22 x 150 | 915 | 1646159 | 5676410 | 147 | 123 |
| T121600 | 600 | 695 | 190 | 203 | 33 | M22 x 150 | 915 | 1756139 | 5853798 | 147 | 128 |

B-LOC®
B115
Inch
Metric



Locking screws transfer to integrated push-off holes for disassembly.

Metric socket head locking screws ISO 4762 grade 12.9 (See M_a for install torque).

Screw head height = screw diameter (mm)

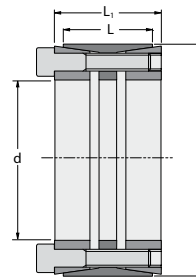

TOLERANCE (T_L)

Bore diameter machined to D -0/+T_L
T_L = .002" for bores up to 4.724"
.003" for bores up to 12.008"
.004" for bores up to 25.000"
.005" for bores over 25.000"

T_L = .05mm for bores up to 120mm
.08mm for bores up to 305mm
.10mm for bores up to 635mm
.13mm for bores over 635mm

d = shaft diameter machined to d +0/-T_L

B115 – Medium Duty – Inch

| Part Number | d (inch) | D (inch) | L (inch) | L ₁ (inch) | Locking Screws | | M _a Install Torque (ft lb) | M _t Maximum Transmitted Torque (ft lb) | Th Thrust (lbs) | P _h Hub Pressure (psi) | Shipping Weight (lb) |
|-------------|----------|----------|----------|-----------------------|----------------|----------|--|--|--------------------|--------------------------------------|----------------------|
| | | | | | Qty | Size | | | | | |
| | | | | | B152212 | 2 3/4 | 4.331 | 1.969 | 2.441 | 8 | |
| B152215 | 2 15/16 | 4.528 | 1.969 | 2.441 | 8 | M10 x 50 | 60 | 5620 | 45913 | 17079 | 5 |
| T152307 | 3 7/16 | 5.118 | 1.969 | 2.441 | 11 | M10 x 50 | 60 | 9042 | 63131 | 20777 | 7 |
| B152308 | 3 1/2 | 5.118 | 1.969 | 2.441 | 11 | M10 x 50 | 60 | 9207 | 63131 | 20777 | 6 |
| B152315 | 3 15/16 | 5.709 | 2.362 | 2.835 | 10 | M12 x 60 | 105 | 14086 | 85858 | 21111 | 9 |
| B152407 | 4 7/16 | 6.496 | 2.362 | 2.835 | 11 | M12 x 60 | 105 | 17462 | 94444 | 20408 | 12 |
| T152408 | 4 1/2 | 6.496 | 2.362 | 2.835 | 11 | M12 x 60 | 105 | 17708 | 94444 | 20408 | 11 |
| T152415 | 4 15/16 | 7.087 | 2.559 | 3.189 | 14 | M12 x 70 | 105 | 24729 | 120202 | 21162 | 15 |
| T152500 | 5 | 7.087 | 2.559 | 3.189 | 14 | M12 x 70 | 105 | 25042 | 120202 | 21162 | 15 |
| B152507 | 5 7/16 | 7.480 | 2.559 | 3.228 | 15 | M12 x 70 | 105 | 29178 | 128787 | 21482 | 15 |
| B152515 | 5 15/16 | 7.874 | 2.559 | 3.228 | 15 | M12 x 70 | 105 | 31861 | 128787 | 20407 | 16 |
| T152600 | 6 | 8.268 | 2.559 | 3.228 | 16 | M12 x 70 | 105 | 34343 | 137373 | 20731 | 19 |
| T152607 | 6 7/16 | 8.858 | 3.071 | 3.661 | 15 | M14 x 80 | 166 | 47013 | 175273 | 20830 | 25 |
| B152615 | 6 15/16 | 9.252 | 3.071 | 3.661 | 15 | M14 x 80 | 166 | 50665 | 175273 | 19944 | 25 |
| B152715 | 7 15/16 | 10.236 | 3.465 | 4.134 | 18 | M14 x 80 | 166 | 69561 | 210328 | 18216 | 31 |
| T152800 | 8 | 10.236 | 3.465 | 4.134 | 18 | M14 x 80 | 166 | 70109 | 210328 | 18216 | 32 |

B115 – Medium Duty – Metric

| Part Number | d (mm) | D (mm) | L (mm) | L ₁ (mm) | Locking Screws | | M _a Install Torque (Nm) | M _t Maximum Transmitted Torque (Nm) | Th Thrust (N) | P _h Hub Pressure (N/mm ²) | Shipping Weight (kg) |
|-------------|--------|--------|--------|---------------------|----------------|-----------|---------------------------------------|---|------------------|---|----------------------|
| | | | | | Qty | Size | | | | | |
| | | | | | B151070 | 70 | 110 | 50 | 62 | 8 | |
| T151075 | 75 | 115 | 50 | 62 | 8 | M10 x 50 | 81 | 7626 | 203362 | 117 | 2 |
| T151080 | 80 | 120 | 50 | 62 | 10 | M10 x 50 | 81 | 10168 | 254202 | 140 | 3 |
| T151090 | 90 | 130 | 50 | 62 | 11 | M10 x 50 | 81 | 12583 | 279622 | 143 | 3 |
| T151095 | 95 | 135 | 50 | 62 | 11 | M10 x 50 | 81 | 13282 | 279622 | 137 | 4 |
| B151100 | 100 | 145 | 60 | 72 | 10 | M12 x 60 | 142 | 19048 | 380966 | 145 | 4 |
| T151110 | 110 | 155 | 60 | 72 | 10 | M12 x 60 | 142 | 20953 | 380966 | 136 | 4 |
| B151120 | 120 | 165 | 60 | 72 | 11 | M12 x 60 | 142 | 25144 | 419063 | 140 | 5 |
| T151130 | 130 | 180 | 65 | 81 | 14 | M12 x 70 | 142 | 34668 | 533353 | 146 | 6 |
| B151140 | 140 | 190 | 65 | 82 | 15 | M12 x 70 | 142 | 40001 | 571449 | 148 | 7 |
| B151150 | 150 | 200 | 65 | 82 | 15 | M12 x 70 | 142 | 42859 | 571449 | 140 | 7 |
| B151160 | 160 | 210 | 65 | 82 | 16 | M12 x 70 | 142 | 48764 | 609546 | 143 | 8 |
| B151170 | 170 | 225 | 78 | 93 | 15 | M14 x 80 | 225 | 66254 | 779456 | 144 | 11 |
| B151180 | 180 | 235 | 78 | 93 | 15 | M14 x 80 | 225 | 70151 | 779456 | 137 | 11 |
| B151190 | 190 | 250 | 88 | 105 | 16 | M14 x 80 | 225 | 78985 | 831420 | 116 | 14 |
| B151200 | 200 | 260 | 88 | 105 | 18 | M14 x 80 | 225 | 93535 | 935348 | 126 | 15 |
| B151220 | 220 | 285 | 96 | 111 | 15 | M16 x 90 | 348 | 116872 | 1062472 | 121 | 19 |
| B151240 | 240 | 305 | 96 | 111 | 20 | M16 x 90 | 348 | 169995 | 1416629 | 150 | 20 |
| T151260 | 260 | 325 | 96 | 111 | 21 | M16 x 90 | 348 | 193370 | 1487460 | 148 | 22 |
| T151280 | 280 | 355 | 96 | 111 | 15 | M20 x 90 | 678 | 231548 | 1653915 | 163 | 27 |
| T151300 | 300 | 375 | 96 | 111 | 15 | M20 x 90 | 678 | 248087 | 1653915 | 154 | 30 |
| T151320 | 320 | 405 | 124 | 136 | 20 | M20 x 110 | 678 | 352835 | 2205220 | 150 | 44 |
| T151340 | 340 | 425 | 124 | 136 | 20 | M20 x 110 | 678 | 374887 | 2205220 | 143 | 47 |
| T151360 | 360 | 455 | 140 | 160 | 20 | M22 x 130 | 915 | 491542 | 2730791 | 133 | 66 |
| T151380 | 380 | 475 | 140 | 160 | 20 | M22 x 130 | 915 | 518850 | 2730791 | 127 | 69 |
| T151400 | 400 | 495 | 140 | 160 | 22 | M22 x 130 | 915 | 600774 | 3003871 | 134 | 72 |
| T151420 | 420 | 515 | 140 | 160 | 24 | M22 x 130 | 915 | 688159 | 3276950 | 141 | 75 |
| T151440 | 440 | 535 | 140 | 160 | 24 | M22 x 130 | 915 | 720929 | 3276950 | 135 | 78 |
| T151460 | 460 | 555 | 140 | 160 | 24 | M22 x 130 | 915 | 753698 | 3276950 | 131 | 82 |
| T151480 | 480 | 575 | 140 | 160 | 25 | M22 x 130 | 915 | 819237 | 3413489 | 131 | 84 |
| T151500 | 500 | 595 | 140 | 160 | 25 | M22 x 130 | 915 | 853372 | 3413489 | 127 | 88 |
| T151520 | 520 | 615 | 140 | 160 | 28 | M22 x 130 | 915 | 994008 | 3823108 | 137 | 91 |
| T151540 | 540 | 635 | 140 | 160 | 28 | M22 x 130 | 915 | 1032239 | 3823108 | 133 | 94 |
| T151560 | 560 | 655 | 140 | 160 | 30 | M22 x 130 | 915 | 1146932 | 4096187 | 138 | 97 |
| T151580 | 580 | 675 | 140 | 160 | 30 | M22 x 130 | 915 | 1187894 | 4096187 | 134 | 100 |
| T151600 | 600 | 695 | 140 | 160 | 30 | M22 x 130 | 915 | 1228856 | 4096187 | 130 | 103 |

B-LOC®
B113
Metric



Locking screws transfer to integrated push-off holes for disassembly.

Metric socket head locking screws ISO 4762 grade 12.9 (See M_a for install torque).

Screw head height = screw diameter (mm)

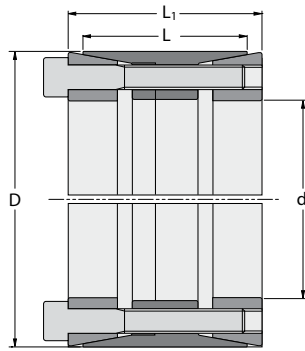

TOLERANCE (T_L)

Bore diameter machined to $D -0/+T_L$
 $T_L =$.064mm for bores up to 285mm
 .08mm for bores up to 355mm
 .09mm for bores up to 615mm
 .10mm for bores up to 675mm
 .13mm for bores over 675mm

$d =$ shaft diameter machined to $d +0/-T_L$

B113 – Extra Heavy Duty – Metric

| Part Number | d (mm) | D (mm) | L (mm) | L ₁ (mm) | Locking Screws | | M _a | M _t | Th | Ph | Shipping Weight (kg) |
|-------------|--------|--------|--------|---------------------|----------------|-----------|---------------------|---------------------|------------|-----------------------------------|----------------------|
| | | | | | Qty | Size | Install Torque (Nm) | Maximum Transmitted | | Hub Pressure (N/mm ²) | |
| | | | | | | | | Torque (Nm) | Thrust (N) | | |
| T131180 | 180 | 285 | 205 | 229 | 14 | M22 x 180 | 915 | 223566 | 2483935 | 139 | 62 |
| T131200 | 200 | 305 | 205 | 229 | 16 | M22 x 180 | 915 | 283878 | 2838783 | 149 | 67 |
| T131220 | 220 | 325 | 205 | 229 | 16 | M22 x 180 | 915 | 312251 | 2838783 | 141 | 73 |
| T131240 | 240 | 355 | 208 | 238 | 16 | M24 x 180 | 1180 | 400322 | 3335957 | 147 | 88 |
| T131260 | 260 | 375 | 208 | 238 | 18 | M24 x 180 | 1180 | 487873 | 3752951 | 156 | 93 |
| T131280 | 280 | 405 | 208 | 238 | 20 | M24 x 180 | 1180 | 583812 | 4169946 | 163 | 110 |
| T131300 | 300 | 425 | 208 | 238 | 20 | M24 x 180 | 1180 | 625491 | 4169946 | 153 | 117 |
| T131320 | 320 | 455 | 250 | 280 | 18 | M27 x 220 | 1763 | 803261 | 5020549 | 149 | 161 |
| T131340 | 340 | 475 | 250 | 280 | 20 | M27 x 220 | 1763 | 948338 | 5578387 | 156 | 170 |
| T131360 | 360 | 495 | 250 | 280 | 22 | M27 x 220 | 1763 | 1104503 | 6136226 | 164 | 177 |
| T131380 | 380 | 515 | 250 | 280 | 22 | M27 x 220 | 1763 | 1165912 | 6136226 | 160 | 186 |
| T131400 | 400 | 535 | 250 | 280 | 22 | M27 x 220 | 1763 | 1227243 | 6136226 | 152 | 192 |
| T131420 | 420 | 555 | 250 | 280 | 24 | M27 x 220 | 1763 | 1405717 | 6694065 | 160 | 202 |
| T131440 | 440 | 575 | 250 | 280 | 24 | M27 x 220 | 1763 | 1472708 | 6694065 | 154 | 210 |
| T131460 | 460 | 595 | 250 | 280 | 24 | M27 x 220 | 1763 | 1539615 | 6694065 | 149 | 220 |
| T131480 | 480 | 615 | 250 | 280 | 28 | M27 x 220 | 1763 | 1874374 | 7809742 | 168 | 227 |
| T131500 | 500 | 635 | 250 | 280 | 28 | M27 x 220 | 1763 | 1952432 | 7809742 | 163 | 233 |
| T131520 | 520 | 655 | 250 | 280 | 28 | M27 x 220 | 1763 | 2030489 | 7809742 | 158 | 244 |
| T131540 | 540 | 675 | 250 | 280 | 30 | M27 x 220 | 1763 | 2259264 | 8367581 | 164 | 251 |
| T131560 | 560 | 695 | 250 | 280 | 30 | M27 x 220 | 1763 | 2342897 | 8367581 | 160 | 260 |

B-LOC®
B117
Metric

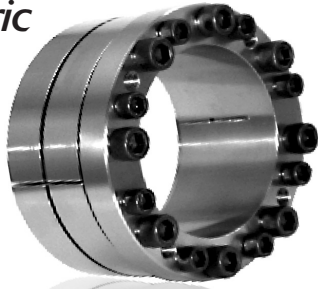

Metric socket head locking screws
ISO 4762 grade 12.9
(See M_a for install torque).

Screw head height = screw diameter (mm)

TOLERANCE (T_L)

Bore diameter machined to $D -0/-T_L$
 $T_L = .05\text{mm}$ for bores up to 120mm
.08mm for bores up to 305mm
.10mm for bores over 305mm

$d =$ Shaft diameter machined to $d +0/-T_L$

B117 – High-Bending – Metric

| Part Number | d (mm) | D (mm) | D ₁ (mm) | L (mm) | L ₁ (mm) | L ₂ (mm) | Locking Screws | | | | | | M _{t1} | M _{t2} | M _{tot} | Th ₁ | Th ₂ | Th _{tot} | P _{h1} | P _{h2} | Shipping Weight (kg) | | | | | | | | |
|-------------|--------|--------|---------------------|--------|---------------------|---------------------|----------------|-----------|------------------------------------|--------|-----------|------------------------------------|-----------------|-----------------|------------------|-----------------|-----------------|-------------------|-----------------|-----------------|----------------------|---------------------|-------------|-------------|---------------------|------------|------------|-----------------------------------|-----------------------------------|
| | | | | | | | SIZE 1 | | | SIZE 2 | | | | | | | | | | | | Maximum Transmitted | | | Maximum Transmitted | | | | |
| | | | | | | | Qty. | Size | M _a Install Torque (Nm) | Qty. | Size | M _a Install Torque (Nm) | | | | | | | | | | Torque (Nm) | Torque (Nm) | Torque (Nm) | Thrust (N) | Thrust (N) | Thrust (N) | Hub Pressure (N/mm ²) | Hub Pressure (N/mm ²) |
| | | | | | | | | | | | | | | | | | | | | | | | | | | | | | |
| B171180 | 180 | 250 | 256 | 40 | 122 | 92 | 8 | M20 x 70 | 678 | 8 | M16 x 110 | 348 | 51569 | 33128 | 84697 | 572990 | 368088 | 941078 | 152 | 98 | 21 | | | | | | | | |
| B171190 | 190 | 260 | 266 | 40 | 122 | 92 | 10 | M20 x 70 | 678 | 10 | M16 x 110 | 348 | 68043 | 43710 | 111753 | 716238 | 460110 | 1176347 | 176 | 113 | 22 | | | | | | | | |
| B171200 | 200 | 270 | 276 | 40 | 122 | 92 | 10 | M20 x 70 | 678 | 10 | M16 x 110 | 348 | 71624 | 46011 | 117635 | 716238 | 460110 | 1176347 | 176 | 113 | 23 | | | | | | | | |
| B171220 | 220 | 290 | 296 | 40 | 122 | 92 | 10 | M20 x 70 | 678 | 10 | M16 x 110 | 348 | 78786 | 50612 | 129398 | 716238 | 460110 | 1176347 | 164 | 105 | 25 | | | | | | | | |
| B171240 | 240 | 310 | 316 | 40 | 122 | 92 | 12 | M20 x 70 | 678 | 12 | M16 x 110 | 348 | 103138 | 66256 | 169394 | 859485 | 552132 | 1411617 | 184 | 118 | 28 | | | | | | | | |
| B171260 | 260 | 330 | 336 | 40 | 122 | 92 | 12 | M20 x 70 | 678 | 12 | M16 x 110 | 348 | 111733 | 71777 | 183510 | 859485 | 552132 | 1411617 | 173 | 111 | 29 | | | | | | | | |
| B171280 | 280 | 365 | 371 | 45 | 144 | 108 | 10 | M24 x 80 | 1180 | 10 | M20 x 130 | 678 | 145918 | 100273 | 246192 | 1042274 | 716238 | 1758512 | 168 | 116 | 45 | | | | | | | | |
| B171300 | 300 | 385 | 391 | 45 | 144 | 108 | 10 | M24 x 80 | 1180 | 10 | M20 x 130 | 678 | 156341 | 107436 | 263777 | 1042274 | 716238 | 1758512 | 160 | 110 | 48 | | | | | | | | |
| B171340 | 340 | 425 | 431 | 45 | 144 | 108 | 14 | M24 x 80 | 1180 | 14 | M20 x 130 | 678 | 248061 | 170465 | 418526 | 1459184 | 1002733 | 2461917 | 202 | 139 | 54 | | | | | | | | |
| B171380 | 380 | 465 | 471 | 45 | 144 | 108 | 16 | M24 x 80 | 1180 | 16 | M20 x 130 | 678 | 316851 | 217736 | 534588 | 1667639 | 1145980 | 2813619 | 211 | 145 | 58 | | | | | | | | |
| B171400 | 400 | 485 | 491 | 45 | 144 | 108 | 16 | M24 x 80 | 1180 | 16 | M20 x 130 | 678 | 333528 | 229196 | 562724 | 1667639 | 1145980 | 2813619 | 203 | 139 | 62 | | | | | | | | |
| B171420 | 420 | 505 | 511 | 45 | 144 | 108 | 16 | M24 x 80 | 1180 | 16 | M20 x 130 | 678 | 350204 | 240656 | 590860 | 1667639 | 1145980 | 2813619 | 195 | 134 | 65 | | | | | | | | |
| B171440 | 440 | 525 | 531 | 59 | 178 | 147 | 16 | M24 x 100 | 1180 | 16 | M20 x 150 | 678 | 366881 | 252116 | 618996 | 1667639 | 1145980 | 2813619 | 143 | 98 | 82 | | | | | | | | |
| B171460 | 460 | 545 | 551 | 59 | 178 | 147 | 16 | M24 x 100 | 1180 | 16 | M20 x 150 | 678 | 383557 | 263575 | 647132 | 1667639 | 1145980 | 2813619 | 138 | 95 | 85 | | | | | | | | |
| B171480 | 480 | 565 | 571 | 59 | 178 | 147 | 16 | M24 x 100 | 1180 | 16 | M20 x 150 | 678 | 400233 | 275035 | 675269 | 1667639 | 1145980 | 2813619 | 133 | 91 | 90 | | | | | | | | |
| B171500 | 500 | 585 | 591 | 59 | 178 | 147 | 18 | M24 x 100 | 1180 | 18 | M20 x 150 | 678 | 469023 | 322307 | 791330 | 1876094 | 1289228 | 3165322 | 144 | 99 | 93 | | | | | | | | |
| B171520 | 520 | 605 | 611 | 59 | 178 | 147 | 18 | M24 x 100 | 1180 | 18 | M20 x 150 | 678 | 487784 | 335199 | 822984 | 1876094 | 1289228 | 3165322 | 139 | 96 | 97 | | | | | | | | |
| B171540 | 540 | 625 | 631 | 59 | 178 | 147 | 18 | M24 x 100 | 1180 | 18 | M20 x 150 | 678 | 506545 | 348092 | 854637 | 1876094 | 1289228 | 3165322 | 135 | 93 | 100 | | | | | | | | |
| B171560 | 560 | 645 | 651 | 59 | 178 | 147 | 18 | M24 x 100 | 1180 | 18 | M20 x 150 | 678 | 525306 | 360984 | 886290 | 1876094 | 1289228 | 3165322 | 131 | 90 | 103 | | | | | | | | |
| B171580 | 580 | 665 | 671 | 59 | 178 | 147 | 20 | M24 x 100 | 1180 | 20 | M20 x 150 | 678 | 604519 | 415418 | 1019937 | 2084549 | 1432475 | 3517024 | 141 | 97 | 107 | | | | | | | | |
| B171600 | 600 | 685 | 691 | 59 | 178 | 147 | 20 | M24 x 100 | 1180 | 20 | M20 x 150 | 678 | 625365 | 429743 | 1055107 | 2084549 | 1432475 | 3517024 | 137 | 94 | 110 | | | | | | | | |

Additional sizes available upon request.

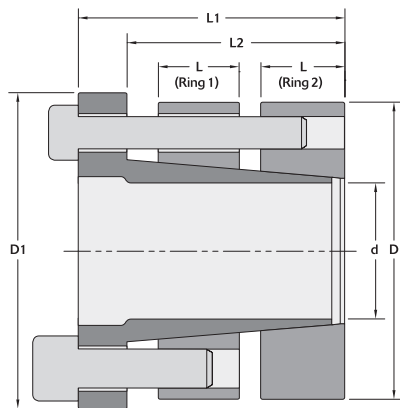

B117 Units, $d \leq 420\text{mm}$

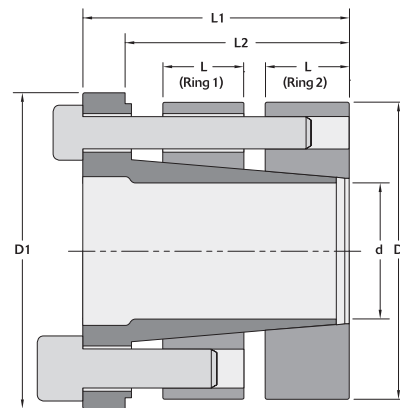

B117 Units, $d \geq 440\text{mm}$



B-LOC[®] SPEED

B-LOC Speed is a new series of keyless locking devices engineered to reduce installation time while maintaining performance.

- Reduce installation time by up to 60%
- Same physical performance as a standard keyless locking device
- Available in three series: S106, S112, S115
- Shaft sizes 4 15/16" – 8", 130mm – 300mm
- Contact Fenner Drives for part numbers and technical information.

Trantorque[®] B-LOC[®]

Fenner Drives Keyless Locking Devices

From precision medical devices to powerful turbines, Fenner Drives Keyless Locking Devices are perfectly suited for use in any industry where there is a need to mount a component to a shaft. Every day, our customers find unique uses for the engineering elegance of our keyless locking devices. The application examples shown are just a small sampling of the many thousands of possible applications for Fenner Drives Keyless Locking Devices. So ask yourself, "What do I need to mount today?"

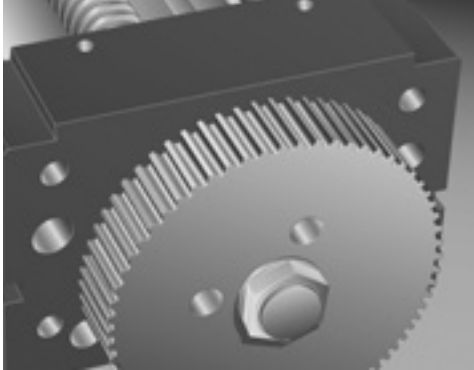

Trantorque Mini provides a solution for mounting components in tight spaces on very small shafts, such as for this timing pulley on a linear slide.

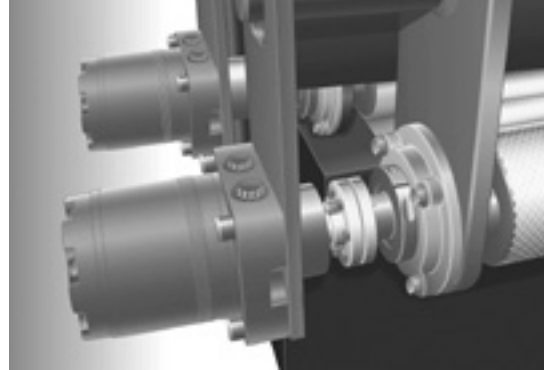

B-LOC Shrink Discs and WK Series Rigid Couplings facilitate torque-arm mounting of hydraulic drives directly onto the driven shaft, eliminating more expensive and less reliable flexible coupling arrangements.

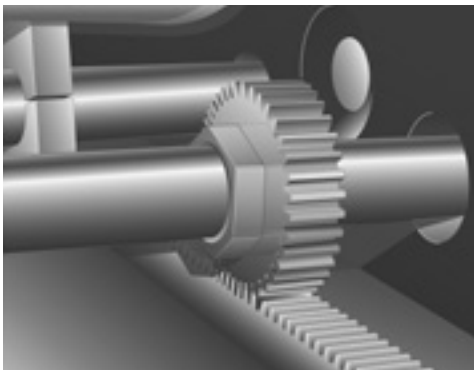

Trantorque OE ensures zero backlash on a rack and pinion drive.

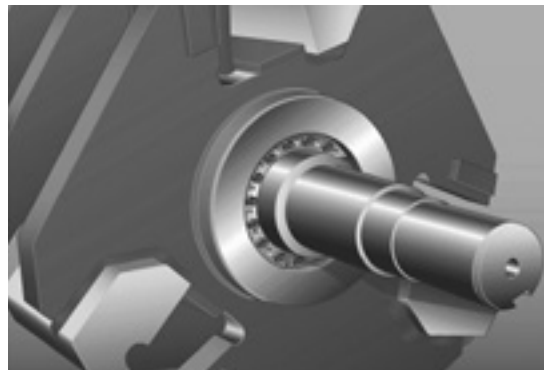

Heavy Duty B112 mounts rotor on an aggregate impact crusher.

SURFACE FINISH

Recommended surface finish for shafts and hub bores to be used with Fenner Drives Keyless Bushings is between 32 and 125 micro-inch (0.8 and 3.2 micro-meter) RMS. A smoother finish — such as that found on components supplied TG&P (turned, ground and polished) — is NOT recommended and can result in a failure of the connection. Note that surface finishes below 32 micro-inch (0.8 micro-meter) RMS can be roughened using longitudinal abrasion with a bastard file, emery paper or similar to achieve a surface finish within the recommended range.

CONCENTRICITY

Fenner Drives Keyless Bushings are precision machined to maximize concentricity and minimize runout. The final installed concentricity of mounted components depends on several variables, including the components themselves and the installation technique employed. Special attention to proper installation will be required for B-LOC® B400 series units. Overall, however, concentricity is typically excellent for the majority of Fenner Drives Keyless Bushings.

POLYMERIC DRIVE COMPONENTS

Fenner Drives Keyless Locking Devices are only recommended for use with drive components constructed of polymers if a metal sleeve of sufficient size and strength is incorporated into the bore of the mounted component. For design and manufacturing support of a suitable sleeve consult with a Fenner Drives Applications Engineer.

TEMPERATURE INFLUENCE

Similar to conventional shrink or press fits, connections using Fenner Drives Keyless Bushings are generally not affected by temperature changes as long as the shaft, hub and bushing are made of the same material and temperatures are applied uniformly to each. For situations where one or more of the components are made of a material with a different coefficient of thermal expansion or where thermal gradients/cycles are present, fit pressures can be impacted. Please consult a Fenner Drives Applications Engineer.

MOUNTING BEARINGS WITH FENNER DRIVES KEYLESS BUSHINGS

Mounting bearings with a Fenner Drives Keyless Bushing is not recommended. The expansion forces generated will distort the bearing’s inner race, causing premature failure.

INSTALLING MULTIPLE FENNER DRIVES KEYLESS BUSHINGS IN SERIES

Additional torque capacity can be achieved by arranging two or more B-LOC Keyless Bushings in series. In these situations, where access to locking screws is available from one side only, the total torque capacity of the connection is not a linear function of the number of units applied. For applications involving B-LOC Keyless Bushings in series, please consult with a Fenner Drives Applications Engineer.

ANAEROBIC ADHESIVES (THREADLOCKER)

Do not use anaerobic adhesives such as Loctite®, Permatex® or similar compounds with Fenner Drives Keyless Bushings. Doing so results in unknown contact pressures and capacities. Further, disassembly may be compromised when such compounds are applied to the keyless bushing, the shaft and/or the hub bore. Proper installation assures sufficient pre-load so that threads are self-locking, even in cases where the keyless bushing is subjected to extreme vibratory conditions.

HOLLOW SHAFTS

Hollow shafts with bores exceeding 35% of outside diameter usually require a reduction of contact pressures in order to avoid permanent shaft deformation. Special considerations arise when installing Fenner Drives Keyless Bushings onto hollow shafts. Please consult with a Fenner Drives Applications Engineer for a trouble free hollow shaft connection.

LUBRICANTS

Trantorque® and B-LOC Keyless Locking Devices are supplied with an oil specific to the product line. The listed performance data requires the use of these lubricants to provide the necessary coefficient of friction to the sliding surfaces. Some products have strategically applied grease or oil (in some cases food grade) to achieve performance.

MATERIALS

Trantorque and B-LOC Keyless Locking Devices are made from carbon and heat treated alloy steels. B-LOC Keyless Bushings are manufactured from heat treated carbon and alloy steels. For applications in corrosive environments, corrosion resistance can be improved through sealing with grease or silicone, the use of protective cover plates, application of industry standard plating materials (e.g., nickel, thin dense chrome, etc.) or by specifying the product in stainless steel or other corrosion resistant materials. Please consult with a Fenner Drives Applications Engineer for more details.

TORQUE

T = peak drive torque = nominal torque multiplied by a variable safety factor to account for stall or start-up conditions, mass accelerations, impact loads, etc. Nominal drive torque can be calculated as follows:

$$M_{t\text{nom}} \text{ (ft lb)} = \frac{5252 \times \text{HP}}{\text{rpm}}$$

$$M_{t\text{nom}} \text{ (Nm)} = \frac{9550 \times \text{kW}}{\text{rpm}}$$

Consult with a Fenner Drives Applications Engineer in cases where “T” is uncertain.

M_t = The rated torque capacity of one Fenner Drives Keyless Bushing installed according to our instructions. Published torque capacities are calculated without using a safety factor and should be considered as the point where a connection could slip if a higher torque is applied. Therefore, always select a unit where $M_t \geq T$.

MODIFIED INSTALLATION TORQUE

The installation torque shown in the data tables is the maximum installation torque recommended for the product. Torque capacity and contact pressures are a linear function of installation torque (M_a) and can be adjusted if necessary by changing M_a within the following limits:

| Series | M_a |
|----------------------|-------------------------------------|
| Trantorque | up to 50% lower |
| B-LOC B103/B106/B109 | up to 20% lower |
| B-LOC B400 | up to 20% higher or up to 20% lower |
| B-LOC B800 | up to 20% lower |
| B-LOC B112/B113 | up to 40% lower |
| B-LOC B115 | up to 30% lower |
| B-LOC B117 | up to 20% lower |

THRUST

T_h = transmissible thrust, determined by using the following equation:

$$T_h = \frac{2 \times M_t}{d}$$

where: d = shaft diameter

M_t = rated torque capacity

TORQUE AND THRUST COMBINED

Simultaneous transmission of torque and thrust requires calculating a resultant torque:

$$M_{t_{res}} = \sqrt{T^2 + \left(\frac{F \times d}{2}\right)^2}$$

where: T = peak drive torque

F = peak thrust load

d = shaft diameter

Select a unit where $M_t \geq M_{t_{res}}$

BENDING MOMENTS

Bending moments are a crucial sizing factor in applications where a radial load from chain pull, the weight of components, etc. acts significantly outside the keyless bushing centerline. Typical applications include rolls or conveyor pulleys where shaft deflection due to radial loads results in a bending moment between shaft and end disc. Generally, bending moments change from a positive to a negative value during each rotation and are designated as rotating or reversing bending moments.

Fenner Drives Keyless Bushings are well suited to transmit rotating/reversing bending moments. Compiled using relevant data gleaned from numerous successful heavy-duty applications in conveyor pulleys as well as pertinent investigations by independent institutions, the following bending moment capacities apply:

| Series | Bending Moment Capacity (M_b) |
|----------------------|-----------------------------------|
| Trantorque | $0.28 \times M_t$ |
| B-LOC B103/B106/B109 | $0.28 \times M_t$ |
| B-LOC B400 | $0.22 \times M_t$ |
| B-LOC B800 | $0.28 \times M_t$ |
| B-LOC B115 | $0.32 \times M_t$ |
| B-LOC B112/B113 | $0.35 \times M_t$ |
| B-LOC B117 | $0.65 \times M_t$ |

where: M_t = rated torque capacity (from specification tables)

Consult with a Fenner Drives Applications Engineer on applications where the actual bending moment exceeds these recommended limits.

TORQUE AND BENDING COMBINED

Simultaneous transmission of torque and bending requires calculating a resultant torque:

$$M_{t_b} = \sqrt{T^2 + (2 \times M_b)^2}$$

where: T = peak drive torque

M_b = bending moment

Always select a unit where $M_t \geq M_{t_b}$ and M_b is within the limits appearing under **Bending Moment Capacity** above.

FENNER DRIVES KEYLESS BUSHINGS WITH SHAFT ADAPTOR SLEEVES

When an existing shaft diameter does not fit the bore of a standard Fenner Drives Keyless Bushing, we recommend using an adapter sleeve that can be sized to allow for the use of a standard unit and the existing shaft. The maximum wall thickness of the adapter sleeve should be approximately 10% of the existing shaft diameter.

Note that in order to maximize the torque capacity of a sleeved keyless bushing connection, the shaft/sleeve bore interface must be free of any lubricant. This makes the sleeve outside diameter/keyless bushing bore the point of lowest torque capacity (provided the sleeve outside diameter is less than 1.25 times the shaft diameter) and allows for full use of the larger keyless bushing's higher torque capacity.

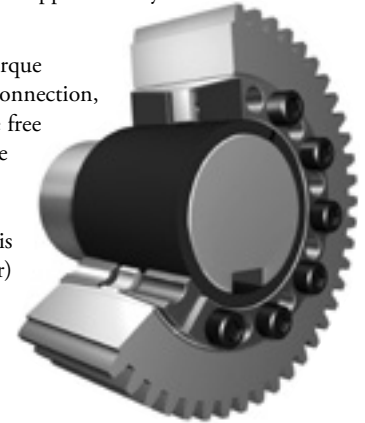

Notes:

- Sleeve ID = $d_s - 0/+0.001$ " (.025mm) where d_s = shaft diameter
- Sleeve OD = $d + 0/-T_L$ for keyless bushing to be used
- Install dry (cleaned with non-petroleum-based solvent) at shaft/sleeve bore interface for coefficient of friction $\mu = 0.15$
- Torque capacity at sleeve OD = M_t for keyless bushing to be used
- Torque capacity on shaft = $M_t \times \frac{d_s}{d} \times 1.25$
- Sleeve to be manufactured with one lengthwise slit (after machining) and from material equal to or better than shaft material
- Sleeve can be installed over existing keyway; position slit approximately opposite keyway

RADIAL LOADS

Radial loads are generated when force is applied perpendicular to the centerline of the shaft and are frequently associated with pin or axle connections (see illustration below). Fenner Drives Keyless Bushings are well suited to provide tight, backlash-free connections for this type of application, as explained below.

$$F_{rad} = \text{radial load capacity} = d \times L \times P_s$$

where: d = shaft diameter

D = hub bore

L = contact length

P_h = hub pressure

P_s = shaft contact pressure = $P_h \times \frac{D}{d}$

Typical pressure distribution in backlash-free pin connections

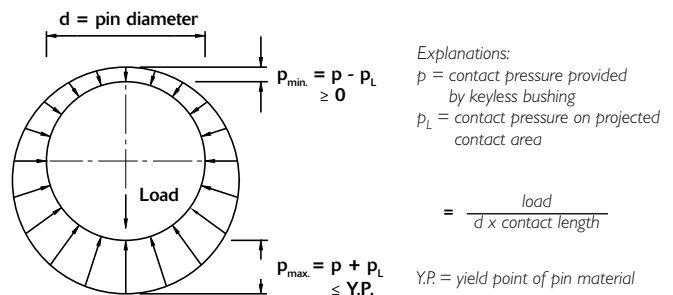

HUB SIZING

Fenner Drives Keyless Bushings transmit torque and other loads by means of mechanical interference generated by pressure exerted on both the shaft and mounted component hub. Therefore, consideration must be given to the amount of hub material (wall thickness) required to prevent permanent expansion (i.e., yielding). The following information is provided to assist you in determining the required hub diameter D_N for any keyless bushing application.

Following standard industry practice, the criterion $\sigma_{ti} < S_y$ is used to determine D_N as follows:

$$D_N = D \sqrt{\frac{S_y + (P_h \times C)}{S_y - (P_h \times C)}}$$

where: D = hub bore diameter (from product specifications)

P_h = contact pressure applied to hub bore (from product specifications)

S_y = yield strength of hub material and

C = Stress Reduction Factor which assumes the value of 1.0, 0.8 or 0.6 depending upon the relationship of your actual hub width H_w to the contact length L of the keyless bushing selected. Use the illustrations on the right to determine C for your application.

| <i>Trantorque®</i> , <i>B-LOC®</i> B109, B103, B106, B117, B400 & B800 | <i>B-LOC®</i> B112, B113, & B115 |
|---|--|
|  <p>$C = 1.0$</p> |  <p>$C = 1.0$</p> |
|  <p>$C = 0.8$</p> |  <p>$C = 0.8$</p> |
|  <p>$C = 0.6$</p> |  <p>$C = 0.6$</p> |

Table 1
Note: Keyless Locking Device outer ring axial position must be roughly centered in the hub.

**THICK WALLED CYLINDER
SUBJECTED TO INTERNAL PRESSURE**

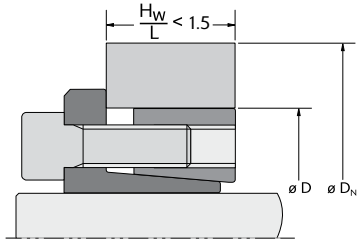
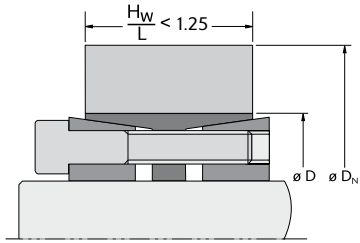
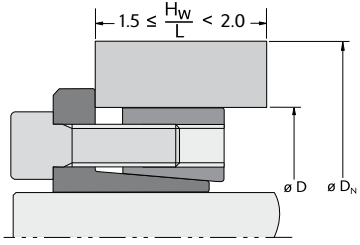
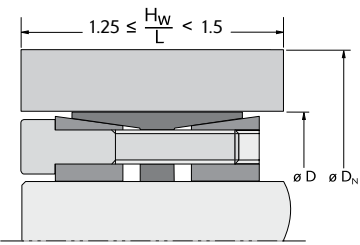
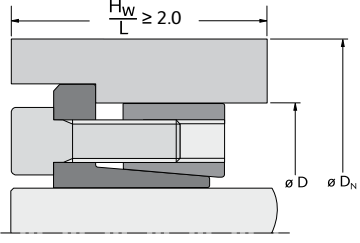
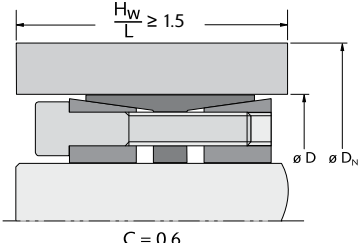
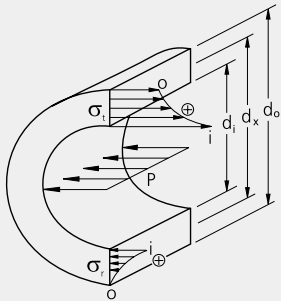

TANGENTIAL STRESSES "s_t"

$$\sigma_{tx} = P \frac{Q}{1-Q} \left[1 + \frac{d_o^2}{d_x^2} \right]$$

$$\sigma_{ti} = P \frac{1+Q}{1-Q}$$

$$\sigma_{to} = 2P \frac{Q}{1-Q}$$

RADIAL STRESSES "s_r"

$$\sigma_{rx} = P \frac{Q}{1-Q} \left[1 - \frac{d_o^2}{d_x^2} \right]$$

$$\sigma_{ri} = -P$$

$$\sigma_{ro} = 0$$

**EXPANSION/
CONTRACTION**

$$\Delta d_i = \frac{Pd_i}{E} \left[\frac{(1+Q)}{(1-Q)} + \nu \right]$$

$$\Delta d_o = 2P \frac{d_o Q}{E(1-Q)}$$

**THICK WALLED CYLINDER
SUBJECTED TO EXTERNAL PRESSURE**

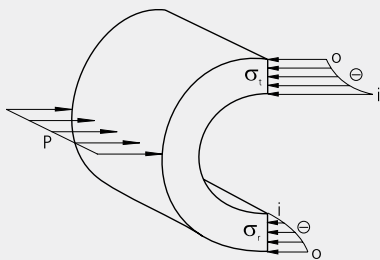

TANGENTIAL STRESSES "s_t"

$$\sigma_{tx} = -\frac{P}{1-Q} \left[1 + \frac{d_i^2}{d_x^2} \right]$$

$$\sigma_{ti} = -\frac{2P}{1-Q}$$

$$\sigma_{to} = -P \frac{1+Q}{1-Q}$$

RADIAL STRESSES "s_r"

$$\sigma_{rx} = -\frac{P}{1-Q} \left[1 - \frac{d_i^2}{d_x^2} \right]$$

$$\sigma_{ri} = 0$$

$$\sigma_{ro} = -P$$

**EXPANSION/
CONTRACTION**

$$\Delta d_i = 2P \frac{d_i}{E(1-Q)}$$

$$\Delta d_o = \frac{Pd_o}{E} \left[\frac{(1+Q)}{(1-Q)} - \nu \right]$$

COMBINED HUB STRESSES $\sigma_v = \sqrt{\sigma_t^2 + \sigma_r^2 - (\sigma_t \sigma_r) + 3\tau^2}$

- KEY**
- i = inside of cylinder
 - o = outside of cylinder
 - ν = Poisson's ratio
for steel: 0.29
 - E = modulus of elasticity
for steel: 3.0×10^7 psi (2.07×10^5 N/mm²)

- P = pressure
- τ = torsional hub stress

$$Q = \left(\frac{d_i}{d_o} \right)^2$$

Example for calculating minimum hub diameter:

Trantorque OE 1", assuming a 2" wide hub made of 55,000 psi yield strength material.

Locate part number 6410100 on page 50.

Record the values for outside diameter D, contact length L, and hub pressure P_h and return to this page.

$$D = 1\frac{1}{2}"$$

$$L = 1"$$

$$P_h = 18,746 \text{ psi}$$

Determine the Stress Reduction Factor C, by first calculating the ratio of hub width to contact length (H_w/L). Next, locate the appropriate product line in Table 1 on previous page to determine C.

NOTE: Contact Fenner Drives Applications Engineering if $\frac{H_w}{L} < 1$

$$\frac{H_w}{L} = 2 \rightarrow C = 0.6$$

The last item required is the yield strength of your mounted component, S_y. This value should be obtainable from the manufacturer of the mounted component or raw material supplier. For this example, the yield strength is 55,000 psi.

Substitute the values obtained above into the minimum hub diameter equation, D_N to obtain your result.

$$D_N = 1.5 \sqrt{\frac{55,000 + (18,746 \times 0.6)}{55,000 - (18,746 \times 0.6)}} = 1.846"$$

Worksheet for calculating minimum hub diameter:

| | <i>Above Example</i> | <i>Your Example</i> |
|--------------------------------|----------------------|---------------------|
| Series | Trantorque OE | |
| Part Number | 6410400 | |
| Size | 1" | |
| Outside diameter, D | 1.5 | |
| Contact Length, L | 1 | |
| Hub Pressure, P _h | 18,746 | |
| Hub Size, H _w | 2" | |
| Yield Strength, S _y | 55,000 psi | |

$$\frac{H_w}{L} = \frac{2}{1} = 2 \rightarrow C = 0.6$$

C is obtained from Table 1 on previous page for Trantorque where $\frac{H_w}{L} \geq 2$

$$\frac{H_w}{L} = \frac{\square}{\square} = \square \rightarrow C = \square$$

$$D_N = D \sqrt{\frac{S_y + (P_h \times C)}{S_y - (P_h \times C)}}$$

$$= 1.5 \sqrt{\frac{55,000 + (18,746 \times 0.6)}{55,000 - (18,746 \times 0.6)}} = 1.846"$$

$$D_N = D \sqrt{\frac{S_y + (P_h \times C)}{S_y - (P_h \times C)}}$$

$$= \square \sqrt{\frac{\square + (\square \times \square)}{\square - (\square \times \square)}} = \square$$

B-LOC[®]
BCH
20
Inch



Metric socket head locking screws ISO 4762 grade 12.9 (See M_a for install torque).

Locking screws transfer to integrated push-off holes for disassembly.

Screw head height = screw diameter (mm)

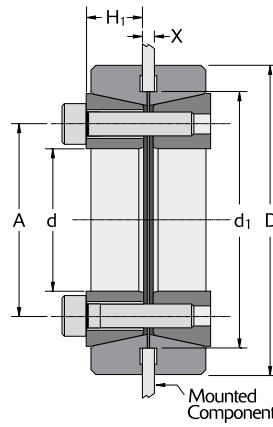

TOLERANCE (T_L)

Recommended bore diameter $d_1 +.001" / +.003"$

$T_L = .002"$ for shafts up to 3"

Shaft diameter machined to $d +0/-T_L$

Parallelism machined to $X +/- .005"$

BCH20 – Light Duty – Inch

| Base Part Number | d (inch) | D (inch) | H_1 (inch) | A (inch) | d_1 (inch) | Locking Screws | | Mounted Component Thickness (X) | | | | M_a | M_t | Th | P_s | Ship Weight (lb) |
|------------------|----------|----------|--------------|----------|--------------|----------------|------|---------------------------------|---------------------|---------------|---------------------|------------------------|---------------------|-------|----------------------|------------------|
| | | | | | | Qty | Size | Range 1 | | Range 2 | | | | | | |
| | | | | | | | | X (inch) | Screw Length 1 (mm) | X (inch) | Screw Length 2 (mm) | Install Torque (ft lb) | Maximum Transmitted | | Shaft Pressure (ksi) | |
| BCH202008 | 1/2 | 1.496 | 0.305 | 0.925 | 1.280 | 4 | M4 | 0.098 – 0.161 | 16 | 0.161 – 0.319 | 20 | 3.5 | 48 | 2320 | 24.7 | 0.2 |
| BCH202010 | 5/8 | 1.496 | 0.305 | 0.925 | 1.280 | 4 | M4 | 0.098 – 0.161 | 16 | 0.161 – 0.319 | 20 | 3.5 | 60 | 2320 | 19.7 | 0.2 |
| BCH202012 | 3/4 | 1.732 | 0.305 | 1.122 | 1.535 | 4 | M4 | 0.098 – 0.161 | 16 | 0.161 – 0.319 | 20 | 3.5 | 72 | 2320 | 16.5 | 0.4 |
| BCH202014 | 7/8 | 1.969 | 0.384 | 1.339 | 1.732 | 4 | M4 | 0.098 – 0.240 | 20 | 0.240 – 0.437 | 25 | 3.5 | 84 | 2320 | 11.3 | 0.4 |
| BCH202015 | 15/16 | 1.969 | 0.384 | 1.339 | 1.732 | 4 | M4 | 0.098 – 0.240 | 20 | 0.240 – 0.437 | 25 | 3.5 | 90 | 2320 | 10.6 | 0.4 |
| BCH202100 | 1 | 1.969 | 0.384 | 1.339 | 1.732 | 4 | M4 | 0.098 – 0.240 | 20 | 0.240 – 0.437 | 25 | 3.5 | 97 | 2320 | 9.9 | 0.4 |
| BCH202102 | 1 1/8 | 2.165 | 0.384 | 1.535 | 1.969 | 5 | M4 | 0.098 – 0.240 | 20 | 0.240 – 0.437 | 25 | 3.5 | 136 | 2990 | 11.3 | 0.7 |
| BCH202103 | 1 3/16 | 2.165 | 0.384 | 1.535 | 1.969 | 5 | M4 | 0.098 – 0.240 | 20 | 0.240 – 0.437 | 25 | 3.5 | 136 | 2990 | 10.7 | 0.7 |
| BCH202104 | 1 1/4 | 2.362 | 0.384 | 1.732 | 2.126 | 6 | M4 | 0.098 – 0.240 | 20 | 0.240 – 0.437 | 25 | 3.5 | 180 | 3570 | 12.2 | 0.7 |
| BCH202106 | 1 3/8 | 2.362 | 0.384 | 1.732 | 2.126 | 6 | M4 | 0.098 – 0.240 | 20 | 0.240 – 0.437 | 25 | 3.5 | 180 | 3570 | 11.2 | 0.7 |
| BCH202107 | 1 7/16 | 2.756 | 0.482 | 2.008 | 2.520 | 4 | M5 | 0.098 – 0.276 | 25 | 0.276 – 0.472 | 30 | 7 | 237 | 4020 | 10.0 | 1.1 |
| BCH202108 | 1 1/2 | 2.756 | 0.482 | 2.008 | 2.520 | 4 | M5 | 0.098 – 0.276 | 25 | 0.276 – 0.472 | 30 | 7 | 237 | 4020 | 9.6 | 1.1 |
| BCH202110 | 1 5/8 | 2.992 | 0.482 | 2.205 | 2.677 | 6 | M5 | 0.098 – 0.276 | 25 | 0.276 – 0.472 | 30 | 7 | 385 | 6050 | 13.2 | 1.3 |
| BCH202111 | 1 11/16 | 2.992 | 0.482 | 2.205 | 2.677 | 6 | M5 | 0.098 – 0.276 | 25 | 0.276 – 0.472 | 30 | 7 | 385 | 6050 | 12.8 | 1.3 |
| BCH202112 | 1 3/4 | 2.992 | 0.482 | 2.205 | 2.677 | 6 | M5 | 0.098 – 0.276 | 25 | 0.276 – 0.472 | 30 | 7 | 385 | 6050 | 12.3 | 1.3 |
| BCH202114 | 1 7/8 | 3.543 | 0.561 | 2.598 | 3.071 | 9 | M5 | 0.098 – 0.394 | 30 | 0.394 – 0.512 | 40 | 7 | 683 | 9060 | 14.8 | 2.2 |
| BCH202115 | 1 15/16 | 3.543 | 0.561 | 2.598 | 3.071 | 9 | M5 | 0.098 – 0.394 | 30 | 0.394 – 0.512 | 40 | 7 | 683 | 9060 | 14.4 | 2.2 |
| BCH202200 | 2 | 3.543 | 0.561 | 2.598 | 3.071 | 9 | M5 | 0.098 – 0.394 | 30 | 0.394 – 0.512 | 40 | 7 | 683 | 9060 | 13.8 | 2.2 |
| BCH202202 | 2 1/8 | 3.543 | 0.561 | 2.598 | 3.071 | 9 | M5 | 0.098 – 0.394 | 30 | 0.394 – 0.512 | 40 | 7 | 683 | 9060 | 13.1 | 2 |
| BCH202203 | 2 3/16 | 3.543 | 0.561 | 2.598 | 3.071 | 9 | M5 | 0.098 – 0.394 | 30 | 0.394 – 0.512 | 40 | 7 | 683 | 9060 | 12.6 | 2 |
| BCH202204 | 2 1/4 | 4.134 | 0.679 | 3.031 | 3.622 | 9 | M6 | 0.098 – 0.429 | 35 | 0.429 – 0.591 | 45 | 12 | 1066 | 12190 | 13.6 | 3.5 |
| BCH202206 | 2 3/8 | 4.134 | 0.679 | 3.031 | 3.622 | 9 | M6 | 0.098 – 0.429 | 35 | 0.429 – 0.591 | 45 | 12 | 1066 | 12190 | 12.9 | 3.3 |
| BCH202207 | 2 7/16 | 4.134 | 0.679 | 3.031 | 3.622 | 9 | M6 | 0.098 – 0.429 | 35 | 0.429 – 0.591 | 45 | 12 | 1066 | 12190 | 12.6 | 3.3 |
| BCH202208 | 2 1/2 | 4.134 | 0.679 | 3.031 | 3.622 | 9 | M6 | 0.098 – 0.429 | 35 | 0.429 – 0.591 | 45 | 12 | 1066 | 12190 | 12.3 | 3.3 |
| BCH202209 | 2 9/16 | 4.134 | 0.679 | 3.031 | 3.622 | 9 | M6 | 0.098 – 0.429 | 35 | 0.429 – 0.591 | 45 | 12 | 1066 | 12190 | 12.0 | 3.1 |
| BCH202210 | 2 5/8 | 4.724 | 0.679 | 3.465 | 4.016 | 12 | M6 | 0.098 – 0.429 | 35 | 0.429 – 0.591 | 45 | 12 | 1617 | 16250 | 15.5 | 4.6 |
| BCH202212 | 2 3/4 | 4.724 | 0.679 | 3.465 | 4.016 | 12 | M6 | 0.098 – 0.429 | 35 | 0.429 – 0.591 | 45 | 12 | 1617 | 16250 | 14.9 | 4.4 |
| BCH202214 | 2 7/8 | 4.724 | 0.679 | 3.465 | 4.016 | 12 | M6 | 0.098 – 0.429 | 35 | 0.429 – 0.591 | 45 | 12 | 1617 | 16250 | 14.2 | 4.2 |
| BCH202215 | 2 15/16 | 4.724 | 0.679 | 3.465 | 4.016 | 12 | M6 | 0.098 – 0.429 | 35 | 0.429 – 0.591 | 45 | 12 | 1617 | 16250 | 13.9 | 4.2 |
| BCH202300 | 3 | 4.724 | 0.679 | 3.465 | 4.016 | 12 | M6 | 0.098 – 0.429 | 35 | 0.429 – 0.591 | 45 | 12 | 1617 | 16250 | 13.6 | 4 |

Part Number Ordering Guide

| | | | | |
|--|---|---------------------------|---|----------------------|
| Base Part Number | + | Screw Length (based on X) | = | Complete Part Number |
| BCH202110 | | 025 | | BCH202110-025 |
| 3 digit whole number Always in mm 25 = 025 | | | | |

NOTES

- B-LOC Compression Hubs exert a maximum pressure on the face of the mounted component of 250 N/mm² (36 ksi).
- B-LOC pilot diameter d_1 machined to ISO tolerance h8.

TOLERANCE (T_L)Recommended bore diameter d₁ +.03mm / +.08mmT_L = .05mm for shafts up to 75mmShaft diameter machined to d +0/-T_L

Parallelism machined to X +/- 0.13mm

BCH20 – Light Duty – Metric

| Base Part Number | d (mm) | D (mm) | H ₁ (mm) | A (mm) | d ₁ (mm) | Locking Screws | | Mounted Component Thickness (X) | | | | M _a | M _t | Th | P _s | Ship Weight (kg) | | |
|------------------|--------|--------|---------------------|--------|---------------------|----------------|----|---------------------------------|------|------------|---------------------|----------------|----------------|------|----------------|------------------|---------------------|---------------------|
| | | | | | | | | Range 1 | | Range 2 | | | | | | | Maximum Transmitted | |
| | | | | | | | | Qty | Size | X (mm) | Screw Length 1 (mm) | | | | | | X (mm) | Screw Length 2 (mm) |
| BCH201012 | 12 | 38 | 7.8 | 23.5 | 32.5 | 4 | M4 | 2.5 – 4.1 | 16 | 4.1 – 8.1 | 20 | 5 | 65 | 10.8 | 189 | 0.1 | | |
| BCH201014 | 14 | 38 | 7.8 | 23.5 | 32.5 | 4 | M4 | 2.5 – 4.1 | 16 | 4.1 – 8.1 | 20 | 5 | 76 | 10.8 | 136 | 0.1 | | |
| BCH201015 | 15 | 38 | 7.8 | 23.5 | 32.5 | 4 | M4 | 2.5 – 4.1 | 16 | 4.1 – 8.1 | 20 | 5 | 81 | 10.8 | 114 | 0.2 | | |
| BCH201018 | 18 | 44 | 7.8 | 28.5 | 39 | 4 | M4 | 2.5 – 4.1 | 16 | 4.1 – 8.1 | 20 | 5 | 97 | 10.8 | 78 | 0.2 | | |
| BCH201019 | 19 | 44 | 7.8 | 28.5 | 39 | 4 | M4 | 2.5 – 4.1 | 16 | 4.1 – 8.1 | 20 | 5 | 103 | 10.8 | 73 | 0.2 | | |
| BCH201020 | 20 | 44 | 7.8 | 28.5 | 39 | 4 | M4 | 2.5 – 4.1 | 16 | 4.1 – 8.1 | 20 | 5 | 108 | 10.8 | 68 | 0.2 | | |
| BCH201022 | 22 | 50 | 9.8 | 34 | 44 | 4 | M4 | 2.5 – 6.1 | 20 | 6.1 – 11.1 | 25 | 5 | 122 | 11.2 | 78 | 0.3 | | |
| BCH201024 | 24 | 50 | 9.8 | 34 | 44 | 4 | M4 | 2.5 – 6.1 | 20 | 6.1 – 11.1 | 25 | 5 | 134 | 11.2 | 74 | 0.3 | | |
| BCH201025 | 25 | 50 | 9.8 | 34 | 44 | 4 | M4 | 2.5 – 6.1 | 20 | 6.1 – 11.1 | 25 | 5 | 140 | 11.2 | 84 | 0.3 | | |
| BCH201028 | 28 | 55 | 9.8 | 39 | 50 | 5 | M4 | 2.5 – 6.1 | 20 | 6.1 – 11.1 | 25 | 5 | 195 | 13.9 | 77 | 0.3 | | |
| BCH201030 | 30 | 55 | 9.8 | 39 | 50 | 5 | M4 | 2.5 – 6.1 | 20 | 6.1 – 11.1 | 25 | 5 | 195 | 13.9 | 69 | 0.5 | | |
| BCH201032 | 32 | 60 | 9.8 | 44 | 54 | 6 | M4 | 2.5 – 6.1 | 20 | 6.1 – 11.1 | 25 | 5 | 257 | 16.7 | 66 | 0.5 | | |
| BCH201035 | 35 | 60 | 9.8 | 44 | 54 | 6 | M4 | 2.5 – 6.1 | 20 | 6.1 – 11.1 | 25 | 5 | 257 | 16.7 | 91 | 0.6 | | |
| BCH201038 | 38 | 70 | 12.3 | 51 | 64 | 4 | M5 | 2.5 – 7 | 25 | 7 – 12 | 30 | 10 | 321 | 17.9 | 88 | 0.6 | | |
| BCH201040 | 40 | 70 | 12.3 | 51 | 64 | 4 | M5 | 2.5 – 7 | 25 | 7 – 12 | 30 | 10 | 321 | 17.9 | 85 | 0.6 | | |
| BCH201042 | 42 | 76 | 12.3 | 56 | 68 | 6 | M5 | 2.5 – 7 | 25 | 7 – 12 | 30 | 10 | 522 | 26.9 | 102 | 1 | | |
| BCH201045 | 45 | 76 | 12.3 | 56 | 68 | 6 | M5 | 2.5 – 7 | 25 | 7 – 12 | 30 | 10 | 522 | 26.9 | 99 | 1 | | |
| BCH201048 | 48 | 90 | 14.3 | 66 | 78 | 9 | M5 | 2.5 – 10 | 30 | 10 – 13 | 40 | 10 | 926 | 40.3 | 95 | 1 | | |
| BCH201050 | 50 | 90 | 14.3 | 66 | 78 | 9 | M5 | 2.5 – 10 | 30 | 10 – 13 | 40 | 10 | 926 | 40.3 | 90 | 0.9 | | |
| BCH201055 | 55 | 90 | 14.3 | 66 | 78 | 9 | M5 | 2.5 – 10 | 30 | 10 – 13 | 40 | 10 | 926 | 40.3 | 87 | 0.9 | | |
| BCH201060 | 60 | 105 | 17.3 | 77 | 92 | 9 | M6 | 2.5 – 10.9 | 35 | 10.9 – 15 | 45 | 16 | 1445 | 54.2 | 94 | 1.6 | | |
| BCH201065 | 65 | 105 | 17.3 | 77 | 92 | 9 | M6 | 2.5 – 10.9 | 35 | 10.9 – 15 | 45 | 16 | 1445 | 54.2 | 89 | 1.5 | | |
| BCH201070 | 70 | 120 | 17.3 | 88 | 102 | 12 | M6 | 2.5 – 10.9 | 35 | 10.9 – 15 | 45 | 16 | 2192 | 72.3 | 87 | 1.5 | | |
| BCH201075 | 75 | 120 | 17.3 | 88 | 102 | 12 | M6 | 2.5 – 10.9 | 35 | 10.9 – 15 | 45 | 16 | 2192 | 72.3 | 85 | 1.5 | | |

Contact our Application Engineers:

- Larger and smaller bore sizes available upon request
- Larger mounted component thickness (outside of X Ranges 1 and 2) can be easily accommodated. Fully-threaded screws are required for mounted component thicknesses larger than X Range 2.
- Fenner Drives can engineer a custom B-LOC Compression Hub to meet your needs.
- Email: AE@fennerdrives.com

B-LOC[®]
BCH
50
Inch

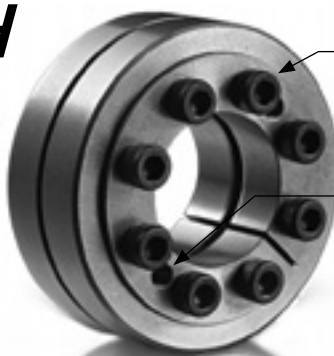

Metric socket head locking screws ISO 4762 grade 12.9 (See M_a for install torque).

Locking screws transfer to integrated push-off holes for disassembly.

Screw head height = screw diameter (mm)

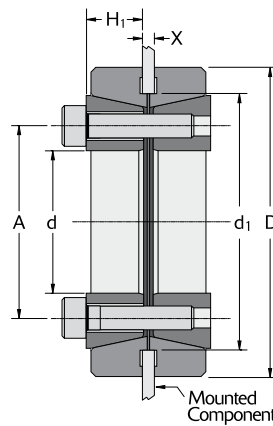

TOLERANCE (T_L)

Recommended bore diameter $d_1 +.001" / +.003"$

$T_L = .002"$ for shafts up to 3"

Shaft diameter machined to $d + d_0/T_L$

Parallelism machined to $X +/- .005"$

BCH50 – Heavy Duty – Inch

| Base Part Number | d (inch) | D (inch) | H_1 (inch) | A (inch) | d_1 (inch) | Locking Screws | | Mounted Component Thickness (X) | | | | M_a | M_t | Th | P_s | Ship Weight (lb) |
|------------------|----------|----------|--------------|----------|--------------|----------------|------|---------------------------------|---------------------|---------------|---------------------|------------------------|----------------|--------------|----------------------|------------------|
| | | | | | | Qty | Size | Range 1 | | Range 2 | | | | | | |
| | | | | | | | | X (inch) | Screw Length 1 (mm) | X (inch) | Screw Length 2 (mm) | Install Torque (ft lb) | Torque (ft lb) | Thrust (lbs) | Shaft Pressure (ksj) | |
| BCH502008 | 1/2 | 1.85 | 0.384 | 0.984 | 1.457 | 5 | M5 | 0.098 – 0.197 | 20 | 0.197 – 0.394 | 25 | 7 | 104 | 4970 | 42.5 | 0.7 |
| BCH502010 | 5/8 | 1.85 | 0.384 | 0.984 | 1.457 | 5 | M5 | 0.098 – 0.197 | 20 | 0.197 – 0.394 | 25 | 7 | 129 | 5510 | 33.9 | 0.4 |
| BCH502012 | 3/4 | 2.047 | 0.384 | 1.181 | 1.654 | 6 | M5 | 0.098 – 0.197 | 20 | 0.197 – 0.394 | 25 | 7 | 186 | 6610 | 33.9 | 0.7 |
| BCH502014 | 7/8 | 2.283 | 0.463 | 1.398 | 1.890 | 6 | M5 | 0.098 – 0.315 | 25 | 0.315 – 0.512 | 30 | 7 | 217 | 6610 | 24.2 | 0.9 |
| BCH502015 | 15/16 | 2.283 | 0.463 | 1.398 | 1.890 | 6 | M5 | 0.098 – 0.315 | 25 | 0.315 – 0.512 | 30 | 7 | 233 | 6610 | 22.6 | 0.9 |
| BCH502100 | 1 | 2.283 | 0.463 | 1.398 | 1.890 | 6 | M5 | 0.098 – 0.315 | 25 | 0.315 – 0.512 | 30 | 7 | 248 | 6610 | 21.2 | 0.9 |
| BCH502102 | 1 1/8 | 2.559 | 0.463 | 1.594 | 2.126 | 8 | M5 | 0.098 – 0.315 | 25 | 0.315 – 0.512 | 30 | 7 | 385 | 9130 | 26.0 | 1.1 |
| BCH502103 | 1 3/16 | 2.559 | 0.463 | 1.594 | 2.126 | 8 | M5 | 0.098 – 0.315 | 25 | 0.315 – 0.512 | 30 | 7 | 406 | 9130 | 24.7 | 1.1 |
| BCH502104 | 1 1/4 | 2.953 | 0.561 | 1.850 | 2.362 | 8 | M6 | 0.098 – 0.350 | 30 | 0.350 – 0.547 | 35 | 12 | 564 | 12030 | 26.5 | 1.8 |
| BCH502106 | 1 3/8 | 2.953 | 0.561 | 1.850 | 2.362 | 8 | M6 | 0.098 – 0.350 | 30 | 0.350 – 0.547 | 35 | 12 | 621 | 12030 | 24.1 | 1.8 |
| BCH502107 | 1 7/16 | 3.307 | 0.561 | 2.047 | 2.598 | 10 | M6 | 0.098 – 0.350 | 30 | 0.350 – 0.547 | 35 | 12 | 811 | 15040 | 28.7 | 2.2 |
| BCH502108 | 1 1/2 | 3.307 | 0.561 | 2.047 | 2.598 | 10 | M6 | 0.098 – 0.350 | 30 | 0.350 – 0.547 | 35 | 12 | 846 | 15040 | 27.6 | 2.2 |
| BCH502110 | 1 5/8 | 3.78 | 0.699 | 2.362 | 2.992 | 7 | M8 | 0.098 – 0.323 | 35 | 0.323 – 0.630 | 45 | 30 | 1261 | 20710 | 28.0 | 3.5 |
| BCH502111 | 1 11/16 | 3.78 | 0.699 | 2.362 | 2.992 | 7 | M8 | 0.098 – 0.323 | 35 | 0.323 – 0.630 | 45 | 30 | 1310 | 20710 | 27.0 | 3.5 |
| BCH502112 | 1 3/4 | 3.78 | 0.699 | 2.362 | 2.992 | 7 | M8 | 0.098 – 0.323 | 35 | 0.323 – 0.630 | 45 | 30 | 1358 | 20710 | 26.0 | 3.5 |
| BCH502114 | 1 7/8 | 4.528 | 0.699 | 2.756 | 3.386 | 8 | M8 | 0.098 – 0.323 | 35 | 0.323 – 0.630 | 45 | 30 | 1663 | 23650 | 27.7 | 5.3 |
| BCH502115 | 1 15/16 | 4.528 | 0.699 | 2.756 | 3.386 | 8 | M8 | 0.098 – 0.323 | 35 | 0.323 – 0.630 | 45 | 30 | 1719 | 23650 | 26.8 | 5.1 |
| BCH502200 | 2 | 4.528 | 0.699 | 2.756 | 3.386 | 8 | M8 | 0.098 – 0.323 | 35 | 0.323 – 0.630 | 45 | 30 | 1774 | 23650 | 26.0 | 5.1 |
| BCH502202 | 2 1/8 | 4.528 | 0.699 | 2.756 | 3.386 | 8 | M8 | 0.098 – 0.323 | 35 | 0.323 – 0.630 | 45 | 30 | 1885 | 23650 | 24.5 | 4.9 |
| BCH502203 | 2 3/16 | 4.528 | 0.699 | 2.756 | 3.386 | 8 | M8 | 0.098 – 0.323 | 35 | 0.323 – 0.630 | 45 | 30 | 1940 | 23650 | 23.8 | 4.9 |
| BCH502204 | 2 1/4 | 5.433 | 0.797 | 3.268 | 4.016 | 8 | M10 | 0.098 – 0.335 | 40 | 0.335 – 0.630 | 50 | 60 | 3198 | 37900 | 32.5 | 8.6 |
| BCH502206 | 2 3/8 | 5.433 | 0.797 | 3.268 | 4.016 | 8 | M10 | 0.098 – 0.335 | 40 | 0.335 – 0.630 | 50 | 60 | 3375 | 37900 | 30.7 | 8.4 |
| BCH502207 | 2 7/16 | 5.433 | 0.797 | 3.268 | 4.016 | 8 | M10 | 0.098 – 0.335 | 40 | 0.335 – 0.630 | 50 | 60 | 3464 | 37900 | 29.9 | 8.4 |
| BCH502208 | 2 1/2 | 5.433 | 0.797 | 3.268 | 4.016 | 8 | M10 | 0.098 – 0.335 | 40 | 0.335 – 0.630 | 50 | 60 | 3553 | 37900 | 29.1 | 8.2 |
| BCH502209 | 2 9/16 | 5.433 | 0.797 | 3.268 | 4.016 | 8 | M10 | 0.098 – 0.335 | 40 | 0.335 – 0.630 | 50 | 60 | 3642 | 37900 | 28.4 | 8.2 |
| BCH502210 | 2 5/8 | 6.142 | 0.797 | 3.740 | 4.409 | 9 | M10 | 0.098 – 0.335 | 40 | 0.335 – 0.630 | 50 | 60 | 4197 | 42630 | 31.3 | 10.8 |
| BCH502212 | 2 3/4 | 6.142 | 0.797 | 3.740 | 4.409 | 9 | M10 | 0.098 – 0.335 | 40 | 0.335 – 0.630 | 50 | 60 | 4396 | 42630 | 29.9 | 10.6 |
| BCH502214 | 2 7/8 | 6.142 | 0.797 | 3.740 | 4.409 | 9 | M10 | 0.098 – 0.335 | 40 | 0.335 – 0.630 | 50 | 60 | 4596 | 42630 | 28.6 | 10.4 |
| BCH502215 | 2 15/16 | 6.142 | 0.797 | 3.740 | 4.409 | 9 | M10 | 0.098 – 0.335 | 40 | 0.335 – 0.630 | 50 | 60 | 4696 | 42630 | 28.0 | 10.1 |
| BCH502300 | 3 | 6.142 | 0.797 | 3.740 | 4.409 | 9 | M10 | 0.098 – 0.335 | 40 | 0.335 – 0.630 | 50 | 60 | 4796 | 42630 | 27.4 | 10.1 |

Part Number Ordering Guide

| | | | | |
|--|---|---------------------------|---|----------------------|
| Base Part Number | + | Screw Length (based on X) | = | Complete Part Number |
| BCH502110 | | 035 | | BCH502110-035 |
| 3 digit whole number Always in mm 35 = 035 | | | | |

NOTES

- B-LOC Compression Hubs exert a maximum pressure on the face of the mounted component of 250 N/mm² (36 ksi).
- B-LOC pilot diameter d_1 machined to ISO tolerance h8.

TOLERANCE (T_L)Recommended bore diameter d₁ +.03mm / +.08mmT_L = .05mm for shafts up to 75mmShaft diameter machined to d +0/-T_L

Parallelism machined to X +/- 0.13mm

BCH50 – Heavy Duty – Metric

| Base Part Number | d (mm) | D (mm) | H ₁ (mm) | A (mm) | d ₁ (mm) | Locking Screws | | Mounted Component Thickness (X) | | | | M _a | M _t | | P _s | Ship Weight (kg) |
|------------------|--------|--------|---------------------|--------|---------------------|----------------|------|---------------------------------|---------------------|------------|---------------------|---------------------|---------------------|-------------|-------------------------------------|------------------|
| | | | | | | | | Range 1 | | Range 2 | | | Maximum Transmitted | | | |
| | | | | | | Qty | Size | X (mm) | Screw Length 1 (mm) | X (mm) | Screw Length 2 (mm) | Install Torque (Nm) | Torque (Nm) | Thrust (kN) | Shaft Pressure (N/mm ²) | |
| BCH501012 | 12 | 47 | 9.8 | 25 | 37.0 | 5 | M5 | 2.5 – 5.0 | 20 | 5.0 – 10.0 | 25 | 10 | 132 | 22.1 | 310 | 0.3 |
| BCH501014 | 14 | 47 | 9.8 | 25 | 37.0 | 5 | M5 | 2.5 – 5.0 | 20 | 5.0 – 10.0 | 25 | 10 | 155 | 22.1 | 266 | 0.2 |
| BCH501015 | 15 | 47 | 9.8 | 25 | 37.0 | 5 | M5 | 2.5 – 5.0 | 20 | 5.0 – 10.0 | 25 | 10 | 166 | 22.1 | 248 | 0.2 |
| BCH501018 | 18 | 52 | 9.8 | 30 | 42.0 | 6 | M5 | 2.5 – 5.0 | 20 | 5.0 – 10.0 | 25 | 10 | 239 | 26.5 | 248 | 0.3 |
| BCH501019 | 19 | 52 | 9.8 | 30 | 42.0 | 6 | M5 | 2.5 – 5.0 | 20 | 5.0 – 10.0 | 25 | 10 | 252 | 26.5 | 235 | 0.3 |
| BCH501020 | 20 | 52 | 9.8 | 30 | 42.0 | 6 | M5 | 2.5 – 5.0 | 20 | 5.0 – 10.0 | 25 | 10 | 265 | 26.5 | 223 | 0.3 |
| BCH501022 | 22 | 58 | 11.8 | 35.5 | 48.0 | 6 | M5 | 2.5 – 8.0 | 25 | 8.0 – 13.0 | 30 | 10 | 302 | 27.4 | 175 | 0.4 |
| BCH501024 | 24 | 58 | 11.8 | 35.5 | 48.0 | 6 | M5 | 2.5 – 8.0 | 25 | 8.0 – 13.0 | 30 | 10 | 329 | 27.4 | 160 | 0.4 |
| BCH501025 | 25 | 58 | 11.8 | 35.5 | 48.0 | 6 | M5 | 2.5 – 8.0 | 25 | 8.0 – 13.0 | 30 | 10 | 342 | 27.4 | 154 | 0.4 |
| BCH501028 | 28 | 65 | 11.8 | 40.5 | 54.0 | 8 | M5 | 2.5 – 8.0 | 25 | 8.0 – 13.0 | 30 | 10 | 511 | 36.5 | 183 | 0.5 |
| BCH501030 | 30 | 65 | 11.8 | 40.5 | 54.0 | 8 | M5 | 2.5 – 8.0 | 25 | 8.0 – 13.0 | 30 | 10 | 548 | 36.5 | 171 | 0.5 |
| BCH501032 | 32 | 75 | 14.3 | 47 | 60.0 | 8 | M6 | 2.5 – 8.9 | 30 | 8.9 – 13.9 | 35 | 16 | 771 | 48.2 | 181 | 0.8 |
| BCH501035 | 35 | 75 | 14.3 | 47 | 60.0 | 8 | M6 | 2.5 – 8.9 | 30 | 8.9 – 13.9 | 35 | 16 | 843 | 48.2 | 166 | 0.8 |
| BCH501038 | 38 | 84 | 14.3 | 52 | 66.0 | 10 | M6 | 2.5 – 8.9 | 30 | 8.9 – 13.9 | 35 | 16 | 1145 | 60.2 | 191 | 1 |
| BCH501040 | 40 | 84 | 14.3 | 52 | 66.0 | 10 | M6 | 2.5 – 8.9 | 30 | 8.9 – 13.9 | 35 | 16 | 1205 | 60.2 | 181 | 0.9 |
| BCH501042 | 42 | 96 | 17.8 | 60 | 76.0 | 7 | M8 | 2.5 – 8.2 | 35 | 8.2 – 16.0 | 45 | 41 | 1740 | 82.9 | 190 | 1.6 |
| BCH501045 | 45 | 96 | 17.8 | 60 | 76.0 | 7 | M8 | 2.5 – 8.2 | 35 | 8.2 – 16.0 | 45 | 41 | 1864 | 82.9 | 177 | 1.6 |
| BCH501048 | 48 | 115 | 17.8 | 70 | 86.0 | 8 | M8 | 2.5 – 8.2 | 35 | 8.2 – 16.0 | 45 | 41 | 2273 | 94.7 | 190 | 2.4 |
| BCH501050 | 50 | 115 | 17.8 | 70 | 86.0 | 8 | M8 | 2.5 – 8.2 | 35 | 8.2 – 16.0 | 45 | 41 | 2367 | 94.7 | 182 | 2.3 |
| BCH501055 | 55 | 115 | 17.8 | 70 | 86.0 | 8 | M8 | 2.5 – 8.2 | 35 | 8.2 – 16.0 | 45 | 41 | 2604 | 94.7 | 166 | 2.2 |
| BCH501060 | 60 | 138 | 20.3 | 83 | 102.0 | 8 | M10 | 2.5 – 8.5 | 40 | 8.5 – 16.0 | 50 | 81 | 4551 | 152 | 213 | 3.8 |
| BCH501065 | 65 | 138 | 20.3 | 83 | 102.0 | 8 | M10 | 2.5 – 8.5 | 40 | 8.5 – 16.0 | 50 | 81 | 4930 | 152 | 197 | 3.7 |
| BCH501070 | 70 | 156 | 20.3 | 95 | 112.0 | 9 | M10 | 2.5 – 8.5 | 40 | 8.5 – 16.0 | 50 | 81 | 5973 | 171 | 205 | 4.8 |
| BCH501075 | 75 | 156 | 20.3 | 95 | 112.0 | 9 | M10 | 2.5 – 8.5 | 40 | 8.5 – 16.0 | 50 | 81 | 6400 | 171 | 192 | 4.6 |

Contact our Application Engineers:

- Larger and smaller bore sizes available upon request
- Larger mounted component thickness (outside of X Ranges 1 and 2) can be easily accommodated. Fully-threaded screws are required for mounted component thicknesses larger than X Range 2.
- Fenner Drives can engineer a custom B-LOC Compression Hub to meet your needs.
- Email: AE@fennerdrives.com

Principles of Operation

B-LOC® Compression Hubs differ from other keyless locking devices in how they engage the mounted component. Rather than creating a radial force on the mounted component, the outer tapered rings are drawn together to generate an axial clamping force. In this way, the mounted component is not subjected to tensile (hoop) stresses. This operating principle also allows narrow components to be mounted with excellent runout.

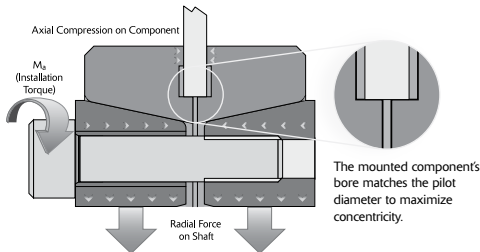

Surface Finish

Recommended surface finish for shafts to be used with B-LOC Compression Hubs is between 32 and 125 microinch (0.8 and 3.2 micrometer) RMS. A smoother finish — such as that found on components supplied TG&P (turned, ground and polished) — is NOT recommended and can result in a failure of the connection. Note that surface finishes below 32 microinch (0.8 micrometer) RMS can be roughened using longitudinal abrasion with a bastard file, emery paper or similar to achieve a surface finish within the recommended range. The recommended surface finish on the contact faces of the mounted component is between 32 and 250 microinch (0.8 – 6.4 micrometer).

Concentricity

Fenner Drives Keyless Locking Devices are precision machined to maximize concentricity and minimize runout. The final installed concentricity of mounted components depends on several variables, including the components themselves and the installation technique employed. In the case of B-LOC Compression Hubs, total runout can be minimized by machining the bore and contacting faces of the mounted component to tight tolerances.

Made to Order

B-LOC Compression Hubs offer a unique design that can provide solutions for applications beyond the standard, single chain sprocket application. Because compression hubs function by clamping the mounted components in the axial

Adhesives & Lubricants

B-LOC Keyless Locking Devices are supplied with an oil specific to the product line. The listed performance data requires the use of these lubricants to provide the necessary coefficient of friction to the sliding surfaces. Likewise, do not use anaerobic adhesives such as Loctite®, Permatex® or similar compounds with Fenner Drives Keyless Locking Devices. Doing so results in unknown contact pressures and capacities. Furthermore, disassembly may be compromised when such compounds are applied to the keyless bushing, the shaft and/or the hub bore. The approved lubricant for use with B-LOC Compression Hubs is CRC3-36.

Materials

B-LOC Keyless Locking Devices are made from carbon steels and heat treated alloy steels. For applications in corrosive environments, corrosion resistance can be improved through sealing with grease or silicone, the use of protective cover plates, application of industry standard plating materials (e.g., nickel, thin dense chrome, etc.) or by specifying the product in stainless steel or other corrosion resistant materials. Please consult with a Fenner Drives Applications Engineer for more details.

Torque

T = peak drive torque = nominal torque multiplied by a safety factor to account for stall or start-up conditions, mass accelerations, impact loads, etc. Nominal drive torque can be calculated as follows:

$$M_{t_{nom}} \text{ (ft lb)} = \frac{5252 \times \text{HP}}{\text{rpm}}$$

$$M_{t_{nom}} \text{ (Nm)} = \frac{9550 \times \text{kW}}{\text{rpm}}$$

Consult with a Fenner Drives Applications Engineer in cases where “T” is uncertain.

M_t = The rated torque capacity of one Fenner Drives Keyless Locking Device installed according to our instructions. Published torque capacities are calculated without using a safety factor and should be considered as the point where a connection could slip if a higher torque is applied. Therefore, always select a unit where M_t ≥ T.

direction, cost savings can be realized by stacking together lower cost individual components. The compression hub simultaneously clamps the assembly together and attaches the assembly to the shaft.



A double strand chain sprocket can be easily made by adding a spacer between two A-plate sprockets.



Applications that require spacing between thin end discs can be accommodated by extending the pilot surface through the end discs so that it engages a spacer and keeps the entire assembly aligned.



Split sprocket designs are simplified by utilizing an A-plate sprocket which is split in a way that provides positive engagement between the two halves.



Metric hex head locking screws
DIN 931 grade 10.9
(See M_a for install torque).

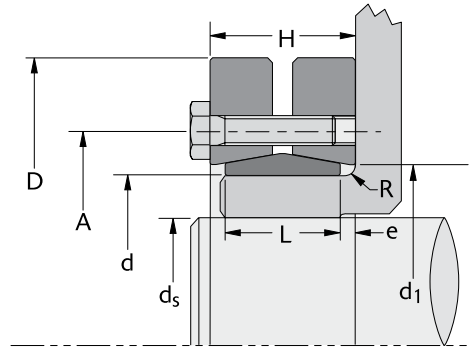

See Table 1 below for maximum diametrical clearance between shaft and hub bore.

SD10 – Standard Duty

| Part Number | Size | SD bore (Hub OD) | | Shaft Diameter Range | | Locking Screws | | M_a Install Torque (ft lb) | M_t Max. Transmitted Torque | | A (inch) | D (inch) | L (inch) | H (inch) | e (inch) | d_1 (inch) | R (inch) | Ship wt (lb) |
|-------------|--------|------------------|----------------|----------------------|---------------|----------------|-----------|---------------------------------|----------------------------------|----------------|----------|----------|----------|----------|----------|--------------|----------|--------------|
| | | d (inch) | $T_1 d$ (inch) | ds-MIN (inch) | ds-MAX (inch) | Qty | Size | | ds-MIN (ft lb) | ds-MAX (ft lb) | | | | | | | | |
| B0241 | 24-10 | 0.945 | + 0 / -0.002 | 5/8 | 0.774 | 6 | M5 x 16 | 3.6 | 138 | 278 | 1.417 | 1.97 | 0.551 | 0.71 | 0.080 | 1.023 | 1/16 | 0.5 |
| B0301 | 30-10 | 1.181 | + 0 / -0.002 | 3/4 | 0.967 | 7 | M5 x 18 | 3.6 | 177 | 407 | 1.732 | 2.36 | 0.629 | 0.79 | 0.081 | 1.259 | 1/16 | 0.7 |
| B0361 | 36-10 | 1.417 | + 0 / -0.002 | 7/8 | 1.161 | 5 | M6 x 20 | 8.7 | 315 | 666 | 2.047 | 2.83 | 0.700 | 0.87 | 0.085 | 1.496 | 1/16 | 0.9 |
| B0441 | 44-10 | 1.732 | + 0 / -0.002 | 1 1/8 | 1.419 | 7 | M6 x 20 | 8.7 | 683 | 1198 | 2.402 | 3.15 | 0.787 | 0.94 | 0.077 | 1.850 | 1/16 | 1.4 |
| B0501 | 50-10 | 1.969 | + 0 / -0.002 | 1 3/8 | 1.612 | 8 | M6 x 22 | 8.7 | 964 | 1565 | 2.756 | 3.54 | 0.866 | 1.02 | 0.077 | 2.086 | 1/16 | 1.8 |
| B0551 | 55-10 | 2.165 | + 0 / -0.002 | 1 1/2 | 1.773 | 8 | M6 x 25 | 8.7 | 1014 | 1707 | 2.953 | 3.94 | 0.905 | 1.14 | 0.118 | 2.283 | 3/32 | 2.4 |
| B0621 | 62-10 | 2.441 | + 0 / -0.002 | 1 3/4 | 1.999 | 10 | M6 x 25 | 8.7 | 1718 | 2375 | 3.386 | 4.33 | 0.905 | 1.14 | 0.118 | 2.598 | 3/32 | 2.9 |
| B0681 | 68-10 | 2.677 | + 0 / -0.002 | 1 7/8 | 2.193 | 10 | M6 x 25 | 8.7 | 1760 | 2606 | 3.386 | 4.53 | 0.905 | 1.14 | 0.118 | 2.834 | 3/32 | 3 |
| B0751 | 75-10 | 2.953 | + 0 / -0.002 | 2 1/8 | 2.418 | 7 | M8 x 25 | 22 | 2792 | 4057 | 3.937 | 5.43 | 0.984 | 1.22 | 0.118 | 3.110 | 1/8 | 3.8 |
| B0801 | 80-10 | 3.150 | + 0 / -0.002 | 2 3/8 | 2.580 | 7 | M8 x 25 | 22 | 3416 | 4331 | 3.937 | 5.71 | 0.984 | 1.22 | 0.118 | 3.307 | 1/8 | 4.2 |
| B0901 | 90-10 | 3.543 | + 0 / -0.004 | 2 1/2 | 2.902 | 10 | M8 x 30 | 22 | 4751 | 7139 | 4.488 | 6.10 | 1.181 | 1.49 | 0.155 | 3.700 | 1/8 | 7 |
| H0951 | 95-10 | 3.740 | + 0 / -0.004 | 2 3/4 | 3.063 | 12 | M8 x 30 | 22 | 6832 | 9108 | 4.882 | 6.69 | 1.338 | 1.69 | 0.176 | 4.094 | 1/8 | 10 |
| B1001 | 100-10 | 3.937 | + 0 / -0.004 | 2 7/8 | 3.224 | 12 | M8 x 35 | 22 | 7059 | 9586 | 4.882 | 6.69 | 1.338 | 1.69 | 0.176 | 4.094 | 1/8 | 10 |
| B1101 | 110-10 | 4.331 | + 0 / -0.004 | 3 1/8 | 3.547 | 9 | M10 x 40 | 44 | 9013 | 12602 | 5.354 | 7.28 | 1.535 | 1.93 | 0.198 | 4.488 | 1/8 | 13 |
| B1251 | 125-10 | 4.921 | + 0 / -0.004 | 3 1/2 | 4.031 | 12 | M10 x 40 | 44 | 13710 | 19540 | 6.299 | 8.46 | 1.653 | 2.04 | 0.194 | 5.275 | 1/8 | 18 |
| B1401 | 140-10 | 5.512 | + 0 / -0.004 | 4 | 4.514 | 10 | M12 x 45 | 74 | 19648 | 26440 | 6.890 | 9.06 | 1.811 | 2.28 | 0.235 | 5.708 | 3/16 | 23 |
| B1551 | 155-10 | 6.102 | + 0 / -0.004 | 4 1/2 | 4.998 | 12 | M12 x 50 | 74 | 27515 | 34049 | 7.559 | 10.36 | 1.968 | 2.44 | 0.236 | 6.496 | 3/16 | 31 |
| H1651 | 165-10 | 6.496 | + 0 / -0.004 | 4 7/8 | 5.320 | 8 | M16 x 55 | 185 | 37737 | 47135 | 8.268 | 11.42 | 2.204 | 2.67 | 0.233 | 6.889 | 3/16 | 49 |
| B1751 | 175-10 | 6.890 | + 0 / -0.004 | 5 1/4 | 5.643 | 8 | M16 x 55 | 185 | 41620 | 50005 | 8.661 | 11.81 | 2.204 | 2.67 | 0.233 | 7.283 | 3/16 | 50 |
| B1851 | 185-10 | 7.283 | + 0 / -0.004 | 5 5/8 | 5.965 | 10 | M16 x 65 | 185 | 56802 | 65965 | 9.291 | 12.99 | 2.795 | 3.34 | 0.273 | 7.677 | 3/16 | 82 |
| H1951 | 195-10 | 7.677 | + 0 / -0.004 | 5 7/8 | 6.288 | 12 | M16 x 65 | 185 | 71908 | 84926 | 9.685 | 13.78 | 2.795 | 3.34 | 0.273 | 8.110 | 3/16 | 91 |
| B2001 | 200-10 | 7.874 | + 0 / -0.004 | 6 1/4 | 6.449 | 12 | M16 x 65 | 185 | 80674 | 87096 | 9.685 | 13.78 | 2.795 | 3.34 | 0.273 | 8.110 | 3/16 | 90 |
| B2201 | 220-10 | 8.661 | + 0 / -0.004 | 6 3/8 | 7.094 | 15 | M16 x 80 | 185 | 92230 | 116425 | 10.630 | 14.57 | 3.464 | 4.06 | 0.298 | 8.897 | 1/4 | 119 |
| B2401 | 240-10 | 9.449 | + 0 / -0.004 | 7 | 7.739 | 12 | M20 x 80 | 362 | 130645 | 161818 | 11.614 | 15.95 | 3.622 | 4.22 | 0.299 | 9.763 | 1/4 | 148 |
| B2601 | 260-10 | 10.236 | + 0 / -0.004 | 7 5/8 | 8.383 | 14 | M20 x 90 | 362 | 162198 | 205263 | 12.638 | 16.93 | 4.055 | 4.72 | 0.318 | 10.551 | 1/4 | 181 |
| H2801 | 280-10 | 11.024 | + 0 / -0.005 | 8 3/8 | 9.028 | 16 | M20 x 100 | 362 | 210581 | 253378 | 13.622 | 18.11 | 4.488 | 5.20 | 0.356 | 11.338 | 5/16 | 225 |
| H3001 | 300-10 | 11.811 | + 0 / -0.005 | 9 | 9.673 | 18 | M20 x 100 | 362 | 257278 | 306749 | 14.331 | 19.10 | 4.803 | 5.52 | 0.359 | 12.125 | 5/16 | 260 |
| H3201 | 320-10 | 12.598 | + 0 / -0.005 | 9 5/8 | 10.318 | 20 | M20 x 100 | 362 | 310492 | 359728 | 15.197 | 20.48 | 4.803 | 5.52 | 0.359 | 12.913 | 5/16 | 288 |
| H3401 | 340-10 | 13.386 | + 0 / -0.005 | 10 1/4 | 10.963 | 24 | M20 x 110 | 362 | 392088 | 462391 | 16.063 | 22.44 | 5.276 | 6.14 | 0.432 | 13.700 | 5/16 | 409 |
| H3501 | 350-10 | 13.780 | + 0 / -0.005 | 10 7/8 | 11.285 | 24 | M20 x 110 | 362 | 432685 | 474097 | 17.008 | 22.84 | 5.511 | 6.30 | 0.395 | 14.488 | 5/16 | 429 |
| H3601 | 360-10 | 14.173 | + 0 / -0.005 | 11 1/4 | 11.608 | 24 | M20 x 110 | 362 | 451405 | 487702 | 17.008 | 23.23 | 5.511 | 6.30 | 0.395 | 14.488 | 5/16 | 449 |
| H3801 | 380-10 | 14.961 | + 0 / -0.005 | 11 1/2 | 12.253 | 20 | M24 x 120 | 620 | 535005 | 623051 | 18.031 | 25.40 | 5.669 | 6.46 | 0.396 | 15.276 | 5/16 | 526 |
| H3901 | 390-10 | 15.354 | + 0 / -0.005 | 12 1/4 | 12.575 | 21 | M24 x 120 | 620 | 633184 | 673847 | 18.425 | 25.99 | 5.669 | 6.46 | 0.396 | 15.629 | 3/8 | 572 |
| H4201 | 420-10 | 16.535 | + 0 / -0.006 | 12 1/2 | 13.543 | 24 | M24 x 130 | 620 | 685493 | 829666 | 19.843 | 27.17 | 6.456 | 7.25 | 0.397 | 16.929 | 3/8 | 630 |
| H4401 | 440-10 | 17.323 | + 0 / -0.006 | 13 1/2 | 14.187 | 24 | M24 x 130 | 620 | 768743 | 852536 | 20.748 | 29.53 | 6.969 | 7.95 | 0.491 | 17.716 | 3/8 | 835 |
| H4601 | 460-10 | 18.110 | + 0 / -0.006 | 14 1/8 | 14.832 | 28 | M24 x 130 | 620 | 934194 | 1051580 | 21.535 | 30.32 | 6.969 | 7.95 | 0.491 | 18.425 | 3/8 | 924 |
| H4801 | 480-10 | 18.898 | + 0 / -0.006 | 14 3/4 | 15.477 | 30 | M24 x 150 | 620 | 1047086 | 1176357 | 22.441 | 31.50 | 7.401 | 8.39 | 0.495 | 19.291 | 1/2 | 1110 |
| H5001 | 500-10 | 19.685 | + 0 / -0.006 | 15 3/8 | 16.122 | 24 | M27 x 150 | 922 | 1169590 | 1310148 | 23.228 | 33.46 | 7.401 | 8.39 | 0.495 | 19.999 | 1/2 | 1265 |

Notes:

- Inner rings of all shrink discs are supplied with one lengthwise slit.
- Shrink discs are available for shafts up to 40" diameter and in a variety of special designs.
- Maximum shaft sizes listed for Shrink Disc Series SD10 and SD30 reflect equal section moduli of shaft and hub (maximum shaft diameter = $\frac{d}{1.221}$).
- Larger shrink discs for shafts up to 40" diameter are available on request.

| Shaft Sizes (inch) | | Maximum Diametrical Clearance Between Shaft and Hub Bore |
|--------------------|---------|--|
| > | ≤ | |
| | 1 1/8 | 0.0010 |
| 1 1/8 | 1 15/16 | 0.0015 |
| 1 15/16 | 4 3/4 | 0.0020 |
| 4 3/4 | 7 | 0.0030 |
| 7 | 10 | 0.0040 |
| 10 | 14 | 0.0050 |
| 14 | | 0.0060 |

Table 1
For Series SD10, SD20 and SD30

B-LOC®
Shrink Disc
SD20
SD30

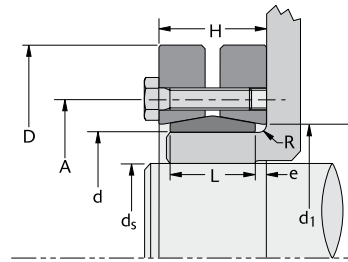
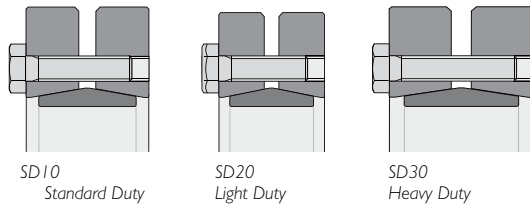

SD20 – Light Duty

| Part Number | Size | SD bore (Hub OD) | | Shaft Diameter Range | | Locking Screws | | M _a | M _t | | A (inch) | D (inch) | L (inch) | H (inch) | e (inch) | d ₁ (inch) | R (inch) | Ship wt (lb) |
|-------------|--------|------------------|-----------------------|----------------------|---------------|----------------|-----------|----------------|------------------------|-------------------------|----------------|----------|----------|----------|----------|-----------------------|----------|--------------|
| | | d (inch) | T _d (inch) | ds-MIN (inch) | ds-MAX (inch) | Qty | Size | | Install Torque (ft lb) | Max. Transmitted Torque | | | | | | | | |
| | | | | | | | | | | ds-MIN (ft lb) | ds-MAX (ft lb) | | | | | | | |
| H1252 | 125-20 | 4.921 | + 0 / -0.004 | 3 5/8 | 4.125 | 8 | M10 x 40 | 44 | 9380 | 13343 | 6.220 | 7.28 | 1.535 | 2.01 | 0.238 | 5.118 | 1/8 | 13 |
| H1402 | 140-20 | 5.512 | + 0 / -0.004 | 4 1/4 | 5.000 | 9 | M10 x 40 | 44 | 13691 | 20328 | 6.889 | 8.67 | 1.535 | 2.01 | 0.238 | 5.669 | 1/8 | 18 |
| H1552 | 155-20 | 6.102 | + 0 / -0.004 | 5 | 5.500 | 11 | M10 x 40 | 44 | 21144 | 27447 | 7.559 | 9.65 | 1.535 | 2.01 | 0.238 | 6.259 | 1/8 | 22 |
| H1652 | 165-20 | 6.496 | + 0 / -0.004 | 5 3/8 | 5.750 | 10 | M12 x 50 | 74 | 30652 | 36677 | 8.267 | 10.24 | 1.811 | 2.44 | 0.315 | 6.653 | 3/16 | 31 |
| H1752 | 175-20 | 6.890 | + 0 / -0.004 | 5 5/8 | 6.125 | 11 | M12 x 50 | 74 | 34940 | 43588 | 8.661 | 10.83 | 1.811 | 2.44 | 0.315 | 7.047 | 3/16 | 35 |
| H1852 | 185-20 | 7.283 | + 0 / -0.004 | 6 | 6.500 | 12 | M12 x 50 | 74 | 41643 | 51035 | 8.858 | 11.62 | 1.811 | 2.44 | 0.315 | 7.440 | 3/16 | 44 |
| H1952 | 195-20 | 7.677 | + 0 / -0.004 | 6 1/2 | 7.000 | 15 | M12 x 60 | 74 | 58979 | 71073 | 9.330 | 12.40 | 2.204 | 2.84 | 0.318 | 7.834 | 3/16 | 60 |
| H2202 | 220-20 | 8.661 | + 0 / -0.004 | 7 | 7.875 | 10 | M16 x 70 | 185 | 76454 | 100895 | 10.433 | 13.59 | 2.598 | 3.31 | 0.356 | 8.818 | 3/16 | 77 |
| H2402 | 240-20 | 9.449 | + 0 / -0.004 | 7 7/8 | 8.500 | 12 | M16 x 70 | 185 | 107011 | 129864 | 11.417 | 14.57 | 2.598 | 3.31 | 0.356 | 9.606 | 1/4 | 97 |
| H2602 | 260-20 | 10.236 | + 0 / -0.004 | 8 5/8 | 9.250 | 14 | M16 x 70 | 185 | 139939 | 166618 | 12.204 | 15.55 | 2.834 | 3.63 | 0.398 | 10.433 | 1/4 | 106 |
| H2802 | 280-20 | 11.024 | + 0 / -0.005 | 9 | 9.875 | 16 | M16 x 75 | 185 | 158724 | 200396 | 13.110 | 16.74 | 3.307 | 4.10 | 0.397 | 11.220 | 1/4 | 132 |
| H3002 | 300-20 | 11.811 | + 0 / -0.005 | 9 7/8 | 10.625 | 18 | M16 x 75 | 185 | 229935 | 271288 | 14.094 | 18.11 | 3.307 | 4.10 | 0.397 | 12.007 | 1/4 | 165 |
| H3202 | 320-20 | 12.598 | + 0 / -0.005 | 10 1/2 | 11.375 | 20 | M16 x 75 | 185 | 238939 | 292045 | 14.881 | 19.49 | 3.307 | 4.18 | 0.437 | 12.795 | 1/4 | 185 |
| H3402 | 340-20 | 13.386 | + 0 / -0.005 | 11 3/8 | 12.000 | 21 | M16 x 75 | 185 | 281000 | 320857 | 15.826 | 21.07 | 3.307 | 4.18 | 0.437 | 13.582 | 1/4 | 220 |
| H3602 | 360-20 | 14.173 | + 0 / -0.005 | 11 7/8 | 12.625 | 16 | M20 x 90 | 362 | 341876 | 398029 | 16.653 | 21.85 | 3.937 | 4.81 | 0.437 | 14.370 | 5/16 | 275 |
| H3802 | 380-20 | 14.961 | + 0 / -0.005 | 12 1/2 | 13.000 | 18 | M20 x 100 | 362 | 403340 | 444630 | 17.401 | 23.03 | 4.409 | 5.35 | 0.471 | 15.236 | 5/16 | 301 |
| H3902 | 390-20 | 15.354 | + 0 / -0.005 | 12 5/8 | 13.750 | 20 | M20 x 100 | 362 | 446171 | 549086 | 17.795 | 23.43 | 4.409 | 5.36 | 0.476 | 15.629 | 5/16 | 344 |
| H4202 | 420-20 | 16.535 | + 0 / -0.006 | 13 3/4 | 14.625 | 22 | M20 x 100 | 362 | 544495 | 625817 | 19.094 | 24.81 | 4.724 | 5.67 | 0.473 | 16.810 | 5/16 | 407 |
| H4602 | 460-20 | 18.110 | + 0 / -0.006 | 14 5/8 | 16.375 | 28 | M20 x 110 | 362 | 704454 | 927856 | 20.747 | 26.97 | 5.196 | 6.22 | 0.512 | 18.425 | 3/8 | 517 |
| H5002 | 500-20 | 19.685 | + 0 / -0.006 | 16 1/4 | 17.375 | 30 | M20 x 120 | 362 | 860127 | 1014952 | 22.519 | 29.53 | 5.984 | 7.01 | 0.513 | 19.999 | 3/8 | 704 |

SD30 – Heavy Duty

| Part Number | Size | SD bore (Hub OD) | | Shaft Diameter Range | | Locking Screws | | M _a | M _t | | A (inch) | D (inch) | L (inch) | H (inch) | e (inch) | d ₁ (inch) | R (inch) | Ship wt (lb) |
|-------------|--------|------------------|-----------------------|----------------------|---------------|----------------|-----------|----------------|------------------------|-------------------------|----------------|----------|----------|----------|----------|-----------------------|----------|--------------|
| | | d (inch) | T _d (inch) | ds-MIN (inch) | ds-MAX (inch) | Qty | Size | | Install Torque (ft lb) | Max. Transmitted Torque | | | | | | | | |
| | | | | | | | | | | ds-MIN (ft lb) | ds-MAX (ft lb) | | | | | | | |
| H0443 | 44-30 | 1.732 | + 0 / -0.002 | 1 1/8 | 1.419 | 5 | M8 x 30 | 22 | 941 | 1653 | 2.598 | 3.35 | 1.102 | 1.34 | 0.119 | 1.890 | 1/16 | 1.4 |
| H0503 | 50-30 | 1.969 | + 0 / -0.002 | 1 3/8 | 1.612 | 7 | M8 x 35 | 22 | 1761 | 2749 | 2.874 | 3.74 | 1.181 | 1.54 | 0.180 | 1.984 | 1/16 | 1.8 |
| H0553 | 55-30 | 2.165 | + 0 / -0.002 | 1 1/2 | 1.773 | 7 | M8 x 35 | 22 | 1892 | 3023 | 3.071 | 4.13 | 1.181 | 1.54 | 0.180 | 2.323 | 3/32 | 2.4 |
| B0623 | 62-30 | 2.441 | + 0 / -0.002 | 1 3/4 | 1.999 | 7 | M8 x 35 | 22 | 2353 | 3244 | 3.346 | 4.53 | 1.181 | 1.54 | 0.180 | 2.598 | 3/32 | 2.9 |
| B0683 | 68-30 | 2.677 | + 0 / -0.002 | 1 7/8 | 2.193 | 8 | M8 x 35 | 22 | 2861 | 4173 | 3.622 | 4.72 | 1.181 | 1.54 | 0.180 | 2.835 | 3/32 | 3 |
| B0753 | 75-30 | 2.953 | + 0 / -0.002 | 2 1/8 | 2.418 | 7 | M10 x 40 | 44 | 4552 | 6529 | 4.134 | 5.71 | 1.417 | 1.81 | 0.197 | 3.307 | 1/8 | 3.8 |
| B0803 | 80-30 | 3.150 | + 0 / -0.002 | 2 3/8 | 2.580 | 7 | M10 x 40 | 44 | 5541 | 6971 | 4.134 | 5.71 | 1.417 | 1.81 | 0.197 | 3.307 | 1/8 | 4.2 |
| B0903 | 90-30 | 3.543 | + 0 / -0.004 | 2 1/2 | 2.902 | 8 | M10 x 40 | 44 | 5946 | 8994 | 4.567 | 6.30 | 1.575 | 1.97 | 0.198 | 3.701 | 1/8 | 7 |
| B1003 | 100-30 | 3.937 | + 0 / -0.004 | 2 7/8 | 3.224 | 10 | M10 x 45 | 44 | 9370 | 12700 | 4.961 | 6.69 | 1.732 | 2.13 | 0.199 | 4.094 | 1/8 | 10 |
| H1103 | 110-30 | 4.331 | + 0 / -0.004 | 3 1/8 | 3.547 | 12 | M10 x 45 | 44 | 12116 | 16879 | 5.354 | 7.28 | 1.969 | 2.36 | 0.196 | 4.482 | 1/8 | 17 |
| H1253 | 125-30 | 4.921 | + 0 / -0.004 | 3 1/2 | 4.031 | 12 | M12 x 50 | 74 | 20092 | 28393 | 6.299 | 8.47 | 2.126 | 2.60 | 0.237 | 5.157 | 3/16 | 24 |
| B1403 | 140-30 | 5.512 | + 0 / -0.004 | 4 | 4.514 | 12 | M12 x 60 | 74 | 23275 | 31491 | 6.889 | 9.06 | 2.362 | 2.92 | 0.279 | 5.744 | 3/16 | 29 |
| H1553 | 155-30 | 6.102 | + 0 / -0.004 | 4 1/2 | 4.998 | 15 | M12 x 60 | 74 | 34154 | 42273 | 7.795 | 10.36 | 2.598 | 3.15 | 0.276 | 6.614 | 3/16 | 44 |
| H1653 | 165-30 | 6.496 | + 0 / -0.004 | 4 7/8 | 5.320 | 10 | M16 x 70 | 185 | 46957 | 58743 | 8.267 | 11.42 | 2.834 | 3.47 | 0.318 | 6.940 | 3/16 | 57 |
| H1753 | 175-30 | 6.890 | + 0 / -0.004 | 5 1/4 | 5.643 | 10 | M16 x 70 | 185 | 51804 | 62320 | 8.661 | 11.82 | 2.834 | 3.47 | 0.318 | 7.322 | 3/16 | 64 |
| H1853 | 185-30 | 7.283 | + 0 / -0.004 | 5 5/8 | 5.965 | 15 | M16 x 80 | 185 | 68647 | 100371 | 9.291 | 12.99 | 3.622 | 4.41 | 0.394 | 7.704 | 3/16 | 104 |
| H1953 | 195-30 | 7.677 | + 0 / -0.004 | 5 7/8 | 6.288 | 15 | M16 x 80 | 185 | 89488 | 105820 | 9.685 | 13.78 | 3.622 | 4.41 | 0.394 | 8.102 | 1/4 | 110 |
| H2003 | 200-30 | 7.874 | + 0 / -0.004 | 6 1/4 | 6.449 | 15 | M16 x 80 | 185 | 100466 | 108524 | 9.685 | 13.78 | 3.622 | 4.41 | 0.394 | 8.102 | 1/4 | 110 |
| H2203 | 220-30 | 8.661 | + 0 / -0.004 | 6 3/8 | 7.094 | 20 | M16 x 90 | 185 | 123458 | 155750 | 10.629 | 14.57 | 4.488 | 5.28 | 0.396 | 8.901 | 1/4 | 143 |
| B2403 | 240-30 | 9.449 | + 0 / -0.004 | 7 | 7.739 | 15 | M20 x 100 | 362 | 162518 | 201425 | 11.614 | 15.95 | 4.724 | 5.67 | 0.473 | 9.692 | 1/4 | 192 |
| H2603 | 260-30 | 10.236 | + 0 / -0.005 | 7 5/8 | 8.383 | 18 | M20 x 110 | 362 | 207733 | 263252 | 12.637 | 16.93 | 5.354 | 6.30 | 0.473 | 10.511 | 1/4 | 220 |
| H2803 | 280-30 | 11.024 | + 0 / -0.005 | 8 3/8 | 9.028 | 21 | M20 x 120 | 362 | 276822 | 332933 | 13.622 | 18.11 | 5.826 | 6.77 | 0.472 | 11.370 | 5/16 | 291 |
| H3003 | 300-30 | 11.811 | + 0 / -0.005 | 9 | 9.673 | 22 | M20 x 120 | 362 | 313789 | 374371 | 14.330 | 19.10 | 5.984 | 6.93 | 0.473 | 12.177 | 5/16 | 308 |
| H3203 | 320-30 | 12.598 | + 0 / -0.005 | 9 5/8 | 10.318 | 24 | M20 x 120 | 362 | 368957 | 427823 | 15.196 | 20.48 | 6.299 | 7.25 | 0.476 | 12.964 | 5/16 | 363 |
| H3403 | 340-30 | 13.386 | + 0 / -0.005 | 10 1/4 | 10.963 | 21 | M24 x 130 | 620 | 489329 | 577963 | 16.535 | 22.44 | 6.929 | 7.88 | 0.476 | 13.724 | 5/16 | 528 |
| H3603 | 360-30 | 14.173 | + 0 / -0.005 | 11 | 11.608 | 22 | M24 x 140 | 620 | 562859 | 642534 | 17.007 | 23.23 | 7.086 | 8.04 | 0.477 | 14.515 | 3/8 | 550 |
| H3903 | 390-30 | 15.354 | + 0 / -0.005 | 11 5/8 | 12.575 | 24 | M24 x 140 | 620 | 628949 | 762028 | 18.425 | 25.99 | 7.401 | 8.35 | 0.475 | 15.609 | 3/8 | 770 |
| H4203 | 420-30 | 16.535 | + 0 / -0.006 | 12 1/2 | 13.543 | 30 | M24 x 160 | 620 | 852841 | 1033732 | 19.842 | 27.17 | 8.425 | 9.37 | 0.472 | 16.811 | 3/8 | 902 |
| H4603 | 460-30 | 18.110 | + 0 / -0.006 | 13 5/8 | 14.832 | 28 | M27 x 170 | 922 | 1144559 | 1403894 | 21.535 | 30.32 | 8.818 | 9.93 | 0.556 | 18.503 | 1/2 | 1188 |
| H5003 | 500-30 | 19.685 | + 0 / -0.006 | 14 7/8 | 16.122 | 32 | M27 x 180 | 922 | 1443359 | 1749331 | 23.622 | 33.47 | 9.685 | 10.79 | 0.552 | 19.999 | 1/2 | 1650 |

Notes: • Inner rings of all shrink discs are supplied with one lengthwise slit.
 • Shrink discs are available for shafts up to 40" diameter and in a variety of special designs.
 • Maximum shaft sizes listed for Shrink Disc Series SD10 and SD30 reflect equal section moduli of shaft and hub (maximum shaft diameter = $\frac{d}{1.221}$).
 • See Table 1 (bottom of page 77) for maximum diametrical clearance between shaft and hub bore.

POWER TRANSMISSION – SHRINK DISCS

B-LOC® Split and Half Shrink Discs

To complement our standard line of B-LOC Shrink Discs, we also offer Split and Half Shrink Discs. These versions are available in all bore sizes listed for standard Shrink Discs. The Split Shrink Disc design allows greater mounting versatility on symmetrical hubs. For applications with tight space constraints and lower performance requirements, Half Shrink Discs provide several compact mounting options.

- **Reduced dimensions** – Perfect for applications with restricted space.
- **Easy Installation** – Standard screws mean installation and removal are achieved using standard tools.
- **Infinite Adjustment** – Simplified design allows hubs to be located and locked virtually anywhere on the shaft.
- **Easy Removal** – Units are self-releasing once the locking screws are loosened, making removal a breeze.
- **Reliability you can count on!** B-LOC Shrink Discs can be tightened and released as often as required.

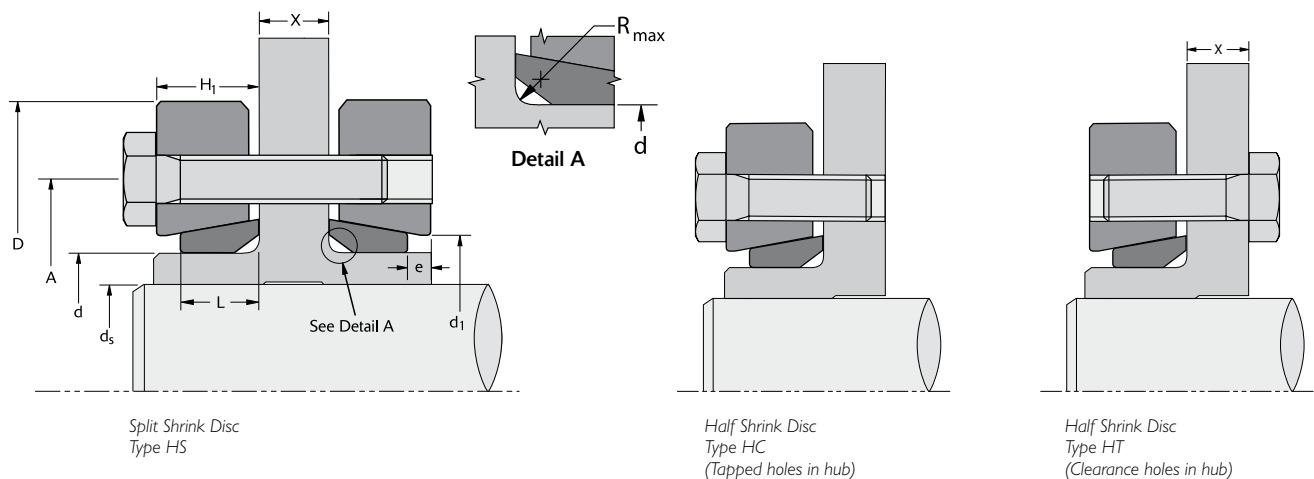

Note: Dimension X is required when ordering Split or Half Shrink Disc Type HT. See Table 1 at bottom left of page 80 for web clearance hole data. Please consult B-LOC Applications Engineering at AE@fennerdrives.com to determine appropriate screw length for your specific application.

Split Shrink Discs

Standard and Light Duty Series: If dimension $X > 2 \times L$ then the transmissible torque may be reduced by up to 50%.

Heavy Duty Series: If dimension $X > 1 \times L$ then the transmissible torque may be reduced by up to 50%.

Half Shrink Discs

Half Shrink Discs HC/HT transmit 50% of the M_t of Shrink Discs and Split Shrink Discs.

B-LOC®
Shrink Disc
Split

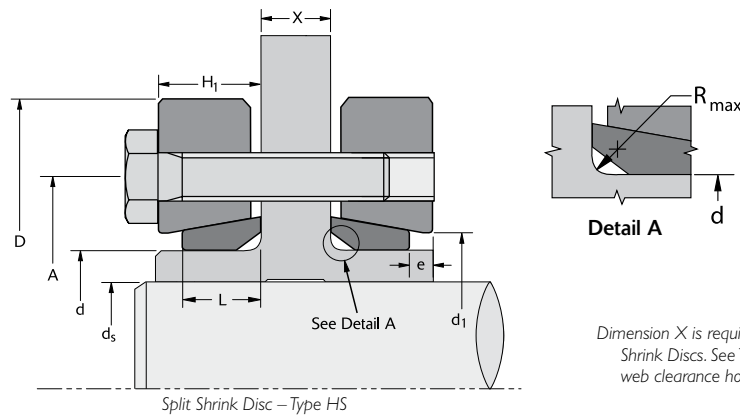

Dimension X is required when ordering Split Shrink Discs. See Table 1 at bottom left for web clearance hole data.

SD10 – Split SD – Standard Duty

| Part Number | Size | SD bore (Hub OD) | | Shaft Diameter Range | | Locking Screws | | M _a | | M _t | | A (inch) | D (inch) | L (inch) | H ₁ (inch) | e (inch) | d ₁ (inch) | R (inch) | Ship wt (lb) |
|-------------|--------|------------------|-------------------------|----------------------|---------------|----------------|------|------------------------|---------------------------------|----------------|----------------|----------|----------|----------|-----------------------|----------|-----------------------|----------|--------------|
| | | d (inch) | T ₁ d (inch) | ds-MIN (inch) | ds-MAX (inch) | Qty | Size | Install Torque (ft lb) | Max. Transmitted Torque (ft lb) | ds-MIN (ft lb) | ds-MAX (ft lb) | | | | | | | | |
| HS0241 | 24-10 | 0.945 | + 0 / -0.002 | 5/8 | 0.774 | 6 | M5 | 3.6 | 138 | 278 | 1.417 | 1.97 | 0.374 | 0.453 | 0.080 | 1.023 | 1/16 | 0.5 | |
| HS0301 | 30-10 | 1.181 | + 0 / -0.002 | 3/4 | 0.967 | 7 | M5 | 3.6 | 177 | 407 | 1.732 | 2.36 | 0.413 | 0.493 | 0.081 | 1.259 | 1/16 | 0.7 | |
| HS0361 | 36-10 | 1.417 | + 0 / -0.002 | 7/8 | 1.161 | 5 | M6 | 8.7 | 315 | 666 | 2.047 | 2.83 | 0.448 | 0.533 | 0.085 | 1.496 | 1/16 | 0.9 | |
| HS0441 | 44-10 | 1.732 | + 0 / -0.002 | 1 1/8 | 1.419 | 7 | M6 | 8.7 | 683 | 1198 | 2.402 | 3.15 | 0.492 | 0.568 | 0.077 | 1.850 | 1/16 | 1.4 | |
| HS0501 | 50-10 | 1.969 | + 0 / -0.002 | 1 3/8 | 1.612 | 8 | M6 | 8.7 | 964 | 1565 | 2.756 | 3.54 | 0.531 | 0.608 | 0.077 | 2.086 | 1/16 | 1.8 | |
| HS0551 | 55-10 | 2.165 | + 0 / -0.002 | 1 1/2 | 1.773 | 8 | M6 | 8.7 | 1014 | 1707 | 2.953 | 3.94 | 0.551 | 0.668 | 0.118 | 2.283 | 3/32 | 2.4 | |
| HS0621 | 62-10 | 2.441 | + 0 / -0.002 | 1 3/4 | 1.999 | 10 | M6 | 8.7 | 1718 | 2375 | 3.386 | 4.33 | 0.551 | 0.668 | 0.118 | 2.598 | 3/32 | 2.9 | |
| HS0681 | 68-10 | 2.677 | + 0 / -0.002 | 1 7/8 | 2.193 | 10 | M6 | 8.7 | 1760 | 2606 | 3.386 | 4.53 | 0.551 | 0.668 | 0.118 | 2.834 | 3/32 | 3 | |
| HS0751 | 75-10 | 2.953 | + 0 / -0.002 | 2 1/8 | 2.418 | 7 | M8 | 22 | 2792 | 4057 | 3.937 | 5.43 | 0.689 | 0.807 | 0.118 | 3.110 | 1/8 | 3.8 | |
| HS0801 | 80-10 | 3.150 | + 0 / -0.002 | 2 3/8 | 2.580 | 7 | M8 | 22 | 3416 | 4331 | 3.937 | 5.71 | 0.689 | 0.807 | 0.118 | 3.307 | 1/8 | 4.2 | |
| HS0901 | 90-10 | 3.543 | + 0 / -0.004 | 2 1/2 | 2.902 | 10 | M8 | 22 | 4751 | 7139 | 4.488 | 6.10 | 0.788 | 0.942 | 0.155 | 3.700 | 1/8 | 7 | |
| HS0951 | 95-10 | 3.740 | + 0 / -0.004 | 2 3/4 | 3.063 | 12 | M8 | 22 | 6832 | 9108 | 4.882 | 6.69 | 0.866 | 1.042 | 0.176 | 4.094 | 1/8 | 10 | |
| HS1001 | 100-10 | 3.937 | + 0 / -0.004 | 2 7/8 | 3.224 | 12 | M8 | 22 | 7059 | 9586 | 4.882 | 6.69 | 0.866 | 1.042 | 0.176 | 4.094 | 1/8 | 10 | |
| HS1101 | 110-10 | 4.331 | + 0 / -0.004 | 3 1/8 | 3.547 | 9 | M10 | 44 | 9013 | 12602 | 5.354 | 7.28 | 0.965 | 1.162 | 0.198 | 4.488 | 1/8 | 13 | |
| HS1251 | 125-10 | 4.921 | + 0 / -0.004 | 3 1/2 | 4.031 | 12 | M10 | 44 | 13710 | 19540 | 6.299 | 8.46 | 1.024 | 1.217 | 0.194 | 5.275 | 1/8 | 18 | |
| HS1401 | 140-10 | 5.512 | + 0 / -0.004 | 4 | 4.514 | 10 | M12 | 74 | 19648 | 26440 | 6.890 | 9.06 | 1.103 | 1.337 | 0.235 | 5.708 | 3/16 | 23 | |
| HS1551 | 155-10 | 6.102 | + 0 / -0.004 | 4 1/2 | 4.998 | 12 | M12 | 74 | 27515 | 34049 | 7.559 | 10.36 | 1.181 | 1.417 | 0.236 | 6.496 | 3/16 | 31 | |
| HS1651 | 165-10 | 6.496 | + 0 / -0.004 | 4 7/8 | 5.320 | 8 | M16 | 185 | 37737 | 47135 | 8.268 | 11.42 | 1.299 | 1.532 | 0.233 | 6.889 | 3/16 | 49 | |
| HS1751 | 175-10 | 6.890 | + 0 / -0.004 | 5 1/4 | 5.643 | 8 | M16 | 185 | 41620 | 50005 | 8.661 | 11.81 | 1.299 | 1.532 | 0.233 | 7.283 | 3/16 | 50 | |
| HS1851 | 185-10 | 7.283 | + 0 / -0.004 | 5 5/8 | 5.965 | 10 | M16 | 185 | 56802 | 65965 | 9.291 | 12.99 | 1.595 | 1.867 | 0.273 | 7.677 | 3/16 | 82 | |
| HS1951 | 195-10 | 7.677 | + 0 / -0.004 | 5 7/8 | 6.288 | 12 | M16 | 185 | 71908 | 84926 | 9.685 | 13.78 | 1.595 | 1.867 | 0.273 | 8.110 | 3/16 | 91 | |
| HS2001 | 200-10 | 7.874 | + 0 / -0.004 | 6 1/4 | 6.449 | 12 | M16 | 185 | 80674 | 87096 | 9.685 | 13.78 | 1.595 | 1.867 | 0.273 | 8.110 | 3/16 | 90 | |
| HS2201 | 220-10 | 8.661 | + 0 / -0.004 | 6 3/8 | 7.094 | 15 | M16 | 185 | 92230 | 116425 | 10.630 | 14.57 | 2.027 | 2.325 | 0.298 | 8.897 | 1/4 | 119 | |
| HS2401 | 240-10 | 9.449 | + 0 / -0.004 | 7 | 7.739 | 12 | M20 | 362 | 130645 | 161818 | 11.614 | 15.95 | 2.106 | 2.405 | 0.299 | 9.763 | 1/4 | 148 | |
| HS2601 | 260-10 | 10.236 | + 0 / -0.004 | 7 5/8 | 8.383 | 14 | M20 | 362 | 162198 | 205263 | 12.638 | 16.93 | 2.323 | 2.640 | 0.318 | 10.551 | 1/4 | 181 | |
| HS2801 | 280-10 | 11.024 | + 0 / -0.005 | 8 3/8 | 9.028 | 16 | M20 | 362 | 210581 | 253378 | 13.622 | 18.11 | 2.638 | 2.994 | 0.356 | 11.338 | 5/16 | 225 | |
| HS3001 | 300-10 | 11.811 | + 0 / -0.005 | 9 | 9.673 | 18 | M20 | 362 | 257278 | 306749 | 14.331 | 19.10 | 2.796 | 3.154 | 0.359 | 12.125 | 5/16 | 260 | |
| HS3201 | 320-10 | 12.598 | + 0 / -0.005 | 9 5/8 | 10.318 | 20 | M20 | 362 | 310492 | 359728 | 15.197 | 20.48 | 2.796 | 3.154 | 0.359 | 12.913 | 5/16 | 288 | |
| HS3401 | 340-10 | 13.386 | + 0 / -0.005 | 10 1/4 | 10.963 | 24 | M20 | 362 | 392088 | 462391 | 16.063 | 22.44 | 3.032 | 3.464 | 0.432 | 13.700 | 5/16 | 409 | |
| HS3501 | 350-10 | 13.780 | + 0 / -0.005 | 10 7/8 | 11.285 | 24 | M20 | 362 | 432685 | 474097 | 17.008 | 22.84 | 3.150 | 3.544 | 0.395 | 14.488 | 5/16 | 429 | |
| HS3601 | 360-10 | 14.173 | + 0 / -0.005 | 11 1/4 | 11.608 | 24 | M20 | 362 | 451405 | 487702 | 17.008 | 23.23 | 3.150 | 3.544 | 0.395 | 14.488 | 5/16 | 449 | |
| HS3801 | 380-10 | 14.961 | + 0 / -0.005 | 11 1/2 | 12.253 | 20 | M24 | 620 | 535005 | 623051 | 18.031 | 25.40 | 3.229 | 3.624 | 0.396 | 15.276 | 5/16 | 526 | |
| HS3901 | 390-10 | 15.354 | + 0 / -0.005 | 12 1/4 | 12.575 | 21 | M24 | 620 | 633184 | 673847 | 18.425 | 25.99 | 3.327 | 3.722 | 0.396 | 15.629 | 3/8 | 572 | |
| HS4201 | 420-10 | 16.535 | + 0 / -0.006 | 12 1/2 | 13.543 | 24 | M24 | 620 | 685493 | 829666 | 19.843 | 27.17 | 3.720 | 4.117 | 0.397 | 16.929 | 3/8 | 630 | |
| HS4401 | 440-10 | 17.323 | + 0 / -0.006 | 13 1/2 | 14.187 | 24 | M24 | 620 | 768743 | 852536 | 20.748 | 29.53 | 3.977 | 4.467 | 0.491 | 17.716 | 3/8 | 835 | |
| HS4601 | 460-10 | 18.110 | + 0 / -0.006 | 14 1/8 | 14.832 | 28 | M24 | 620 | 934194 | 1051580 | 21.535 | 30.32 | 3.977 | 4.467 | 0.491 | 18.425 | 3/8 | 924 | |
| HS4801 | 480-10 | 18.898 | + 0 / -0.006 | 14 3/4 | 15.477 | 30 | M24 | 620 | 1047086 | 1176357 | 22.441 | 31.50 | 4.292 | 4.786 | 0.495 | 19.291 | 1/2 | 1110 | |
| HS5001 | 500-10 | 19.685 | + 0 / -0.006 | 15 3/8 | 16.122 | 24 | M27 | 922 | 1169590 | 1310148 | 23.228 | 33.46 | 4.292 | 4.786 | 0.495 | 19.999 | 1/2 | 1265 | |

| Specifications for Web Clearance Holes (diameter in inches) | | | | | | | | | |
|---|-------|-------|-------|-------|-------|-------|-------|-------|-------|
| Screw Size | M5 | M6 | M8 | M10 | M12 | M16 | M20 | M24 | M27 |
| Split Shrink Disc | 0.281 | 0.328 | 0.406 | 0.500 | 0.594 | 0.750 | 0.906 | 1.063 | 1.188 |
| Half Shrink Disc HT | 0.219 | 0.266 | 0.359 | 0.438 | 0.531 | 0.719 | 0.875 | 1.031 | 1.156 |

Table 1

- Notes:
- Screw length must be determined based on your X dimension. Please consult Applications Engineering.
 - Inner rings of all shrink discs are supplied with one lengthwise slit.
 - Shrink discs are available for shafts up to 40" diameter and in a variety of special designs.
 - Maximum shaft sizes listed for Shrink Disc Series SD10 and SD30 reflect equal section moduli of shaft and hub (maximum shaft diameter = $\frac{d}{1.221}$).
 - Larger shrink discs for shafts up to 40" diameter are available on request.

| Shaft Sizes (inch) | | Maximum Diametrical Clearance Between Shaft and Hub Bore |
|--------------------|---------|--|
| > | ≤ | |
| 1 1/8 | 1 15/16 | 0.0010 |
| 1 15/16 | 4 3/4 | 0.0015 |
| 4 3/4 | 7 | 0.0030 |
| 7 | 10 | 0.0040 |
| 10 | 14 | 0.0050 |
| 14 | | 0.0060 |

Table 2
For Series SD10, SD20 and SD30

SD20 – Split SD – Light Duty

| Part Number | Size | SD bore (Hub OD) | | Hub OD Tolerance | | Shaft Diameter Range | | Locking Screws | | M _a Install Torque (ft lb) | M _t Max. Transmitted Torque | | A (inch) | D (inch) | L (inch) | H ₁ (inch) | e (inch) | d ₁ (inch) | R (inch) | Ship wt (lb) |
|-------------|--------|------------------|-------------------------|------------------|---------------|----------------------|-------|----------------|----------------|--|---|-------|----------|----------|----------|-----------------------|----------|-----------------------|----------|--------------|
| | | d (inch) | T ₁ d (inch) | ds-MIN (inch) | ds-MAX (inch) | Qty | Size | ds-MIN (ft lb) | ds-MAX (ft lb) | | | | | | | | | | | |
| | | HS1252 | 125-20 | 4.921 | + 0 / -0.004 | 3 5/8 | 4.125 | 8 | M10 | | 44 | 9380 | | | | | | | | |
| HS1402 | 140-20 | 5.512 | + 0 / -0.004 | 4 1/4 | 5.000 | 9 | M10 | 44 | 13691 | 20328 | 6.889 | 8.67 | 0.965 | 1.202 | 0.238 | 5.669 | 1/8 | 18 | | |
| HS1552 | 155-20 | 6.102 | + 0 / -0.004 | 5 | 5.500 | 11 | M10 | 44 | 21144 | 27447 | 7.559 | 9.65 | 0.965 | 1.202 | 0.238 | 6.259 | 1/8 | 22 | | |
| HS1652 | 165-20 | 6.496 | + 0 / -0.004 | 5 3/8 | 5.750 | 10 | M12 | 74 | 30652 | 36677 | 8.267 | 10.24 | 1.103 | 1.417 | 0.315 | 6.653 | 3/16 | 31 | | |
| HS1752 | 175-20 | 6.890 | + 0 / -0.004 | 5 5/8 | 6.125 | 11 | M12 | 74 | 34940 | 43588 | 8.661 | 10.83 | 1.103 | 1.417 | 0.315 | 7.047 | 3/16 | 35 | | |
| HS1852 | 185-20 | 7.283 | + 0 / -0.004 | 6 | 6.500 | 12 | M12 | 74 | 41643 | 51035 | 8.858 | 11.62 | 1.103 | 1.417 | 0.315 | 7.440 | 3/16 | 44 | | |
| HS1952 | 195-20 | 7.677 | + 0 / -0.004 | 6 1/2 | 7.000 | 15 | M12 | 74 | 58979 | 71073 | 9.330 | 12.40 | 1.299 | 1.617 | 0.318 | 7.834 | 3/16 | 60 | | |
| HS2202 | 220-20 | 8.661 | + 0 / -0.004 | 7 | 7.875 | 10 | M16 | 185 | 76454 | 100895 | 10.433 | 13.59 | 1.496 | 1.852 | 0.356 | 8.818 | 3/16 | 77 | | |
| HS2402 | 240-20 | 9.449 | + 0 / -0.004 | 7 7/8 | 8.500 | 12 | M16 | 185 | 107011 | 129864 | 11.417 | 14.57 | 1.594 | 1.950 | 0.356 | 9.606 | 1/4 | 97 | | |
| HS2602 | 260-20 | 10.236 | + 0 / -0.004 | 8 5/8 | 9.250 | 14 | M16 | 185 | 139939 | 166618 | 12.204 | 15.55 | 1.712 | 2.110 | 0.398 | 10.433 | 1/4 | 106 | | |
| HS2802 | 280-20 | 11.024 | + 0 / -0.005 | 9 | 9.875 | 16 | M16 | 185 | 158724 | 200396 | 13.110 | 16.74 | 1.949 | 2.345 | 0.397 | 11.220 | 1/4 | 132 | | |
| HS3002 | 300-20 | 11.811 | + 0 / -0.005 | 9 7/8 | 10.625 | 18 | M16 | 185 | 229935 | 271288 | 14.094 | 18.11 | 1.949 | 2.345 | 0.397 | 12.007 | 1/4 | 165 | | |
| HS3202 | 320-20 | 12.598 | + 0 / -0.005 | 10 1/2 | 11.375 | 20 | M16 | 185 | 238939 | 292045 | 14.881 | 19.49 | 1.949 | 2.385 | 0.437 | 12.795 | 1/4 | 185 | | |
| HS3402 | 340-20 | 13.386 | + 0 / -0.005 | 11 3/8 | 12.000 | 21 | M16 | 185 | 281000 | 320857 | 15.826 | 21.07 | 1.949 | 2.385 | 0.437 | 13.582 | 1/4 | 220 | | |
| HS3602 | 360-20 | 14.173 | + 0 / -0.005 | 11 7/8 | 12.625 | 16 | M20 | 362 | 341876 | 398029 | 16.653 | 21.85 | 2.363 | 2.799 | 0.437 | 14.370 | 5/16 | 275 | | |
| HS3802 | 380-20 | 14.961 | + 0 / -0.005 | 12 1/2 | 13.000 | 18 | M20 | 362 | 403340 | 444630 | 17.401 | 23.03 | 2.599 | 3.069 | 0.471 | 15.236 | 5/16 | 301 | | |
| HS3902 | 390-20 | 15.354 | + 0 / -0.005 | 12 5/8 | 13.750 | 20 | M20 | 362 | 446171 | 549086 | 17.795 | 23.43 | 2.599 | 3.074 | 0.476 | 15.629 | 5/16 | 344 | | |
| HS4202 | 420-20 | 16.535 | + 0 / -0.006 | 13 3/4 | 14.625 | 22 | M20 | 362 | 544495 | 625817 | 19.094 | 24.81 | 2.756 | 3.229 | 0.473 | 16.810 | 5/16 | 407 | | |
| HS4602 | 460-20 | 18.110 | + 0 / -0.006 | 14 5/8 | 16.375 | 28 | M20 | 362 | 704454 | 927856 | 20.747 | 26.97 | 3.090 | 3.602 | 0.512 | 18.425 | 3/8 | 517 | | |
| HS5002 | 500-20 | 19.685 | + 0 / -0.006 | 16 1/4 | 17.375 | 30 | M20 | 362 | 860127 | 1014952 | 22.519 | 29.53 | 3.484 | 3.997 | 0.513 | 19.999 | 3/8 | 704 | | |

SD30 – Split SD – Heavy Duty

| Part Number | Size | SD bore (Hub OD) | | Hub OD Tolerance | | Shaft Diameter Range | | Locking Screws | | M _a Install Torque (ft lb) | M _t Max. Transmitted Torque | | A (inch) | D (inch) | L (inch) | H ₁ (inch) | e (inch) | d ₁ (inch) | R (inch) | Ship wt (lb) |
|-------------|--------|------------------|-------------------------|------------------|---------------|----------------------|-------|----------------|----------------|--|---|-------|----------|----------|----------|-----------------------|----------|-----------------------|----------|--------------|
| | | d (inch) | T ₁ d (inch) | ds-MIN (inch) | ds-MAX (inch) | Qty | Size | ds-MIN (ft lb) | ds-MAX (ft lb) | | | | | | | | | | | |
| | | HS0443 | 44-30 | 1.732 | + 0 / -0.002 | 1 1/8 | 1.419 | 5 | M8 | | 22 | 941 | | | | | | | | |
| HS0503 | 50-30 | 1.969 | + 0 / -0.002 | 1 3/8 | 1.612 | 7 | M8 | 22 | 1761 | 2749 | 2.874 | 3.74 | 0.689 | 0.868 | 0.180 | 1.984 | 1/16 | 1.8 | | |
| HS0553 | 55-30 | 2.165 | + 0 / -0.002 | 1 1/2 | 1.773 | 7 | M8 | 22 | 1892 | 3023 | 3.071 | 4.13 | 0.689 | 0.868 | 0.180 | 2.323 | 3/32 | 2.4 | | |
| HS0623 | 62-30 | 2.441 | + 0 / -0.002 | 1 3/4 | 1.999 | 7 | M8 | 22 | 2353 | 3244 | 3.346 | 4.53 | 0.689 | 0.868 | 0.180 | 2.598 | 3/32 | 2.9 | | |
| HS0683 | 68-30 | 2.677 | + 0 / -0.002 | 1 7/8 | 2.193 | 8 | M8 | 22 | 2861 | 4173 | 3.622 | 4.72 | 0.689 | 0.868 | 0.180 | 2.835 | 3/32 | 3 | | |
| HS0753 | 75-30 | 2.953 | + 0 / -0.002 | 2 1/8 | 2.418 | 7 | M10 | 44 | 4552 | 6529 | 4.134 | 5.71 | 0.906 | 1.102 | 0.197 | 3.307 | 1/8 | 3.8 | | |
| HS0803 | 80-30 | 3.150 | + 0 / -0.002 | 2 3/8 | 2.580 | 7 | M10 | 44 | 5541 | 6971 | 4.134 | 5.71 | 0.906 | 1.102 | 0.197 | 3.307 | 1/8 | 4.2 | | |
| HS0903 | 90-30 | 3.543 | + 0 / -0.004 | 2 1/2 | 2.902 | 8 | M10 | 44 | 5946 | 8994 | 4.567 | 6.30 | 0.985 | 1.182 | 0.198 | 3.701 | 1/8 | 7 | | |
| HS1003 | 100-30 | 3.937 | + 0 / -0.004 | 2 7/8 | 3.224 | 10 | M10 | 44 | 9370 | 12700 | 4.961 | 6.69 | 1.063 | 1.262 | 0.199 | 4.094 | 1/8 | 10 | | |
| HS1103 | 110-30 | 4.331 | + 0 / -0.004 | 3 1/8 | 3.547 | 12 | M10 | 44 | 12116 | 16879 | 5.354 | 7.28 | 1.182 | 1.377 | 0.196 | 4.482 | 1/8 | 17 | | |
| HS1253 | 125-30 | 4.921 | + 0 / -0.004 | 3 1/2 | 4.031 | 12 | M12 | 74 | 20092 | 28393 | 6.299 | 8.47 | 1.260 | 1.497 | 0.237 | 5.157 | 3/16 | 24 | | |
| HS1403 | 140-30 | 5.512 | + 0 / -0.004 | 4 | 4.514 | 12 | M12 | 74 | 23275 | 31491 | 6.889 | 9.06 | 1.378 | 1.657 | 0.279 | 5.744 | 3/16 | 29 | | |
| HS1553 | 155-30 | 6.102 | + 0 / -0.004 | 4 1/2 | 4.998 | 15 | M12 | 74 | 34154 | 42273 | 7.795 | 10.36 | 1.496 | 1.772 | 0.276 | 6.496 | 3/16 | 44 | | |
| HS1653 | 165-30 | 6.496 | + 0 / -0.004 | 4 7/8 | 5.320 | 10 | M16 | 185 | 46957 | 58743 | 8.267 | 11.42 | 1.614 | 1.932 | 0.318 | 6.940 | 3/16 | 57 | | |
| HS1753 | 175-30 | 6.890 | + 0 / -0.004 | 5 1/4 | 5.643 | 10 | M16 | 185 | 51804 | 62320 | 8.661 | 11.82 | 1.614 | 1.932 | 0.318 | 7.322 | 3/16 | 64 | | |
| HS1853 | 185-30 | 7.283 | + 0 / -0.004 | 5 5/8 | 5.965 | 15 | M16 | 185 | 68847 | 100371 | 9.291 | 12.99 | 2.008 | 2.402 | 0.394 | 7.704 | 3/16 | 104 | | |
| HS1953 | 195-30 | 7.677 | + 0 / -0.004 | 5 7/8 | 6.288 | 15 | M16 | 185 | 89488 | 105820 | 9.685 | 13.78 | 2.106 | 2.500 | 0.394 | 8.102 | 1/4 | 110 | | |
| HS2003 | 200-30 | 7.874 | + 0 / -0.004 | 6 1/4 | 6.449 | 15 | M16 | 185 | 100466 | 108524 | 9.685 | 13.78 | 2.106 | 2.500 | 0.394 | 8.102 | 1/4 | 110 | | |
| HS2203 | 220-30 | 8.661 | + 0 / -0.004 | 6 3/8 | 7.094 | 20 | M16 | 185 | 123458 | 155750 | 10.629 | 14.57 | 2.539 | 2.935 | 0.396 | 8.901 | 1/4 | 143 | | |
| HS2403 | 240-30 | 9.449 | + 0 / -0.004 | 7 | 7.739 | 15 | M20 | 362 | 162518 | 201425 | 11.614 | 15.95 | 2.657 | 3.130 | 0.473 | 9.692 | 1/4 | 192 | | |
| HS2603 | 260-30 | 10.236 | + 0 / -0.005 | 7 5/8 | 8.383 | 18 | M20 | 362 | 207733 | 263252 | 12.637 | 16.93 | 2.972 | 3.445 | 0.473 | 10.511 | 1/4 | 220 | | |
| HS2803 | 280-30 | 11.024 | + 0 / -0.005 | 8 3/8 | 9.028 | 21 | M20 | 362 | 276822 | 332933 | 13.622 | 18.11 | 3.307 | 3.779 | 0.472 | 11.370 | 5/16 | 291 | | |
| HS3003 | 300-30 | 11.811 | + 0 / -0.005 | 9 | 9.673 | 22 | M20 | 362 | 313789 | 374371 | 14.330 | 19.10 | 3.386 | 3.859 | 0.473 | 12.177 | 5/16 | 308 | | |
| HS3203 | 320-30 | 12.598 | + 0 / -0.005 | 9 5/8 | 10.318 | 24 | M20 | 362 | 368957 | 427823 | 15.196 | 20.48 | 3.544 | 4.019 | 0.476 | 12.964 | 5/16 | 363 | | |
| HS3403 | 340-30 | 13.386 | + 0 / -0.005 | 10 1/4 | 10.963 | 21 | M24 | 620 | 489329 | 577963 | 16.535 | 22.44 | 3.859 | 4.334 | 0.476 | 13.724 | 5/16 | 528 | | |
| HS3603 | 360-30 | 14.173 | + 0 / -0.005 | 11 | 11.608 | 22 | M24 | 620 | 562859 | 642534 | 17.007 | 23.23 | 4.035 | 4.512 | 0.477 | 14.515 | 3/8 | 550 | | |
| HS3903 | 390-30 | 15.354 | + 0 / -0.005 | 11 5/8 | 12.575 | 24 | M24 | 620 | 628949 | 762028 | 18.425 | 25.99 | 4.193 | 4.667 | 0.475 | 15.609 | 3/8 | 770 | | |
| HS4203 | 420-30 | 16.535 | + 0 / -0.006 | 12 1/2 | 13.543 | 30 | M24 | 620 | 852841 | 1033732 | 19.842 | 27.17 | 4.705 | 5.177 | 0.472 | 16.811 | 3/8 | 902 | | |
| HS4603 | 460-30 | 18.110 | + 0 / -0.006 | 13 5/8 | 14.832 | 28 | M27 | 922 | 1144559 | 1403894 | 21.535 | 30.32 | 5.000 | 5.556 | 0.556 | 18.503 | 1/2 | 1188 | | |
| HS5003 | 500-30 | 19.685 | + 0 / -0.006 | 14 7/8 | 16.122 | 32 | M27 | 922 | 1443359 | 1749331 | 23.622 | 33.47 | 5.434 | 5.986 | 0.552 | 19.999 | 1/2 | 1650 | | |

B-LOC® Shrink Disc Half

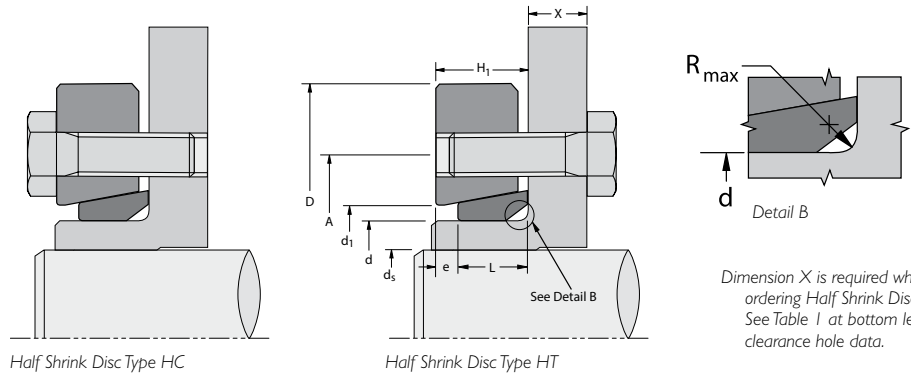

Dimension X is required when ordering Half Shrink Disc Type HT. See Table 1 at bottom left for web clearance hole data.

SD10 – Half SD – Standard Duty

| Type HC Part Number | Type HT Part Number | Size | SD bore (Hub OD) | | Hub OD Tolerance | | Shaft Diameter Range | | Locking Screws | | | M _a | | M _t | | A (inch) | D (inch) | L (inch) | H ₁ (inch) | e (inch) | d ₁ (inch) | R (inch) | Ship wt (lb) |
|---------------------|---------------------|--------|------------------|-----------------------|------------------|---------------|----------------------|-----------|----------------|------------------------|---------------------------------|----------------|----------------|----------------|-------|----------|----------|----------|-----------------------|----------|-----------------------|----------|--------------|
| | | | d (inch) | T _d (inch) | ds-MIN (inch) | ds-MAX (inch) | Qty | HC Size | HT Size | Install Torque (ft lb) | Max. Transmitted Torque (ft lb) | ds-MIN (ft lb) | ds-MAX (ft lb) | | | | | | | | | | |
| HHC0241 | HHT0241 | 24-10 | 0.945 | + 0 / -0.002 | 5/8 | 0.774 | 6 | M5 x 16 | M5 | 3.6 | 69 | 139 | 1.417 | 1.97 | 0.374 | 0.453 | 0.080 | 1.023 | 1/16 | 0.3 | | | |
| HHC0301 | HHT0301 | 30-10 | 1.181 | + 0 / -0.002 | 3/4 | 0.967 | 7 | M5 x 18 | M5 | 3.6 | 89 | 204 | 1.732 | 2.36 | 0.413 | 0.493 | 0.081 | 1.259 | 1/16 | 0.4 | | | |
| HHC0361 | HHT0361 | 36-10 | 1.417 | + 0 / -0.002 | 7/8 | 1.161 | 5 | M6 x 20 | M6 | 8.7 | 158 | 333 | 2.047 | 2.83 | 0.448 | 0.533 | 0.085 | 1.496 | 1/16 | 0.6 | | | |
| HHC0441 | HHT0441 | 44-10 | 1.732 | + 0 / -0.002 | 1 1/8 | 1.419 | 7 | M6 x 20 | M6 | 8.7 | 342 | 599 | 2.402 | 3.15 | 0.492 | 0.568 | 0.077 | 1.850 | 1/16 | 0.8 | | | |
| HHC0501 | HHT0501 | 50-10 | 1.969 | + 0 / -0.002 | 1 3/8 | 1.612 | 8 | M6 x 22 | M6 | 8.7 | 482 | 783 | 2.756 | 3.54 | 0.531 | 0.608 | 0.072 | 2.086 | 1/16 | 1 | | | |
| HHC0551 | HHT0551 | 55-10 | 2.165 | + 0 / -0.002 | 1 1/2 | 1.773 | 8 | M6 x 25 | M6 | 8.7 | 507 | 854 | 2.953 | 3.94 | 0.551 | 0.668 | 0.118 | 2.283 | 3/32 | 1.4 | | | |
| HHC0621 | HHT0621 | 62-10 | 2.441 | + 0 / -0.002 | 1 3/4 | 1.999 | 10 | M6 x 25 | M6 | 8.7 | 859 | 1188 | 3.386 | 4.33 | 0.551 | 0.668 | 0.118 | 2.598 | 3/32 | 1.6 | | | |
| HHC0681 | HHT0681 | 68-10 | 2.677 | + 0 / -0.002 | 1 7/8 | 2.193 | 10 | M6 x 25 | M6 | 8.7 | 880 | 1303 | 3.386 | 4.53 | 0.551 | 0.668 | 0.118 | 2.834 | 3/32 | 1.6 | | | |
| HHC0751 | HHT0751 | 75-10 | 2.953 | + 0 / -0.002 | 2 1/8 | 2.418 | 7 | M8 x 25 | M8 | 22 | 1396 | 2029 | 3.937 | 5.43 | 0.689 | 0.807 | 0.118 | 3.110 | 1/8 | 2.6 | | | |
| HHC0801 | HHT0801 | 80-10 | 3.150 | + 0 / -0.002 | 2 3/8 | 2.580 | 7 | M8 x 25 | M8 | 22 | 1708 | 2166 | 3.937 | 5.71 | 0.689 | 0.807 | 0.118 | 3.307 | 1/8 | 2.8 | | | |
| HHC0901 | HHT0901 | 90-10 | 3.543 | + 0 / -0.004 | 2 1/2 | 2.902 | 10 | M8 x 30 | M8 | 22 | 2376 | 3570 | 4.488 | 6.10 | 0.788 | 0.942 | 0.155 | 3.700 | 1/8 | 4 | | | |
| HHC0951 | HHT0951 | 95-10 | 3.740 | + 0 / -0.004 | 2 3/4 | 3.063 | 12 | M8 x 30 | M8 | 22 | 3416 | 4554 | 4.882 | 6.69 | 0.866 | 1.042 | 0.176 | 4.094 | 1/8 | 6 | | | |
| HHC1001 | HHT1001 | 100-10 | 3.937 | + 0 / -0.004 | 2 7/8 | 3.224 | 12 | M8 x 35 | M8 | 22 | 3530 | 4793 | 4.882 | 6.69 | 0.866 | 1.042 | 0.176 | 4.094 | 1/8 | 6 | | | |
| HHC1101 | HHT1101 | 110-10 | 4.331 | + 0 / -0.004 | 3 1/8 | 3.547 | 9 | M10 x 40 | M10 | 44 | 4507 | 6301 | 5.354 | 7.28 | 0.965 | 1.162 | 0.198 | 4.488 | 1/8 | 7 | | | |
| HHC1251 | HHT1251 | 125-10 | 4.921 | + 0 / -0.004 | 3 1/2 | 4.031 | 12 | M10 x 40 | M10 | 44 | 6855 | 9770 | 6.299 | 8.46 | 1.024 | 1.217 | 0.194 | 5.275 | 1/8 | 11 | | | |
| HHC1401 | HHT1401 | 140-10 | 5.512 | + 0 / -0.004 | 4 | 4.514 | 10 | M12 x 45 | M12 | 74 | 9824 | 13220 | 6.890 | 9.06 | 1.103 | 1.337 | 0.235 | 5.708 | 3/16 | 13 | | | |
| HHC1551 | HHT1551 | 155-10 | 6.102 | + 0 / -0.004 | 4 1/2 | 4.998 | 12 | M12 x 50 | M12 | 74 | 13758 | 17025 | 7.559 | 10.36 | 1.181 | 1.417 | 0.236 | 6.496 | 3/16 | 17 | | | |
| HHC1651 | HHT1651 | 165-10 | 6.496 | + 0 / -0.004 | 4 7/8 | 5.320 | 8 | M16 x 55 | M16 | 185 | 18869 | 23568 | 8.268 | 11.42 | 1.299 | 1.532 | 0.233 | 6.889 | 3/16 | 24 | | | |
| HHC1751 | HHT1751 | 175-10 | 6.890 | + 0 / -0.004 | 5 1/4 | 5.643 | 8 | M16 x 55 | M16 | 185 | 20810 | 25003 | 8.661 | 11.81 | 1.299 | 1.532 | 0.233 | 7.283 | 3/16 | 25 | | | |
| HHC1851 | HHT1851 | 185-10 | 7.283 | + 0 / -0.004 | 5 5/8 | 5.965 | 10 | M16 x 65 | M16 | 185 | 28401 | 32983 | 9.291 | 12.99 | 1.595 | 1.867 | 0.273 | 7.677 | 3/16 | 39 | | | |
| HHC1951 | HHT1951 | 195-10 | 7.677 | + 0 / -0.004 | 5 7/8 | 6.288 | 12 | M16 x 65 | M16 | 185 | 35954 | 42463 | 9.685 | 13.78 | 1.595 | 1.867 | 0.273 | 8.110 | 3/16 | 44 | | | |
| HHC2001 | HHT2001 | 200-10 | 7.874 | + 0 / -0.004 | 6 1/4 | 6.449 | 12 | M16 x 65 | M16 | 185 | 40337 | 43548 | 9.685 | 13.78 | 1.595 | 1.867 | 0.273 | 8.110 | 3/16 | 43 | | | |
| HHC2201 | HHT2201 | 220-10 | 8.661 | + 0 / -0.004 | 6 3/8 | 7.094 | 15 | M16 x 80 | M16 | 185 | 46115 | 58213 | 10.630 | 14.57 | 2.027 | 2.325 | 0.298 | 8.897 | 1/4 | 57 | | | |
| HHC2401 | HHT2401 | 240-10 | 9.449 | + 0 / -0.004 | 7 | 7.739 | 12 | M20 x 80 | M20 | 362 | 65323 | 80909 | 11.614 | 15.95 | 2.106 | 2.405 | 0.299 | 9.763 | 1/4 | 72 | | | |
| HHC2601 | HHT2601 | 260-10 | 10.236 | + 0 / -0.004 | 7 5/8 | 8.383 | 14 | M20 x 90 | M20 | 362 | 81099 | 102632 | 12.638 | 16.93 | 2.323 | 2.640 | 0.318 | 10.551 | 1/4 | 89 | | | |
| HHC2801 | HHT2801 | 280-10 | 11.024 | + 0 / -0.005 | 8 3/8 | 9.028 | 16 | M20 x 100 | M20 | 362 | 105291 | 126689 | 13.622 | 18.11 | 2.638 | 2.994 | 0.356 | 11.338 | 5/16 | 115 | | | |
| HHC3001 | HHT3001 | 300-10 | 11.811 | + 0 / -0.005 | 9 | 9.673 | 18 | M20 x 100 | M20 | 362 | 128639 | 153375 | 14.331 | 19.10 | 2.796 | 3.154 | 0.359 | 12.125 | 5/16 | 133 | | | |
| HHC3201 | HHT3201 | 320-10 | 12.598 | + 0 / -0.005 | 9 5/8 | 10.318 | 20 | M20 x 100 | M20 | 362 | 155246 | 179864 | 15.197 | 20.48 | 2.796 | 3.154 | 0.359 | 12.913 | 5/16 | 153 | | | |
| HHC3401 | HHT3401 | 340-10 | 13.386 | + 0 / -0.005 | 10 1/4 | 10.963 | 24 | M20 x 110 | M20 | 362 | 196044 | 231196 | 16.063 | 22.44 | 3.032 | 3.464 | 0.432 | 13.700 | 5/16 | 209 | | | |
| HHC3501 | HHT3501 | 350-10 | 13.780 | + 0 / -0.005 | 10 7/8 | 11.285 | 24 | M20 x 110 | M20 | 362 | 216343 | 237049 | 17.008 | 22.84 | 3.150 | 3.544 | 0.395 | 14.488 | 5/16 | 220 | | | |
| HHC3601 | HHT3601 | 360-10 | 14.173 | + 0 / -0.005 | 11 1/4 | 11.608 | 24 | M20 x 110 | M20 | 362 | 225703 | 243851 | 17.008 | 23.23 | 3.150 | 3.544 | 0.395 | 14.488 | 5/16 | 225 | | | |
| HHC3801 | HHT3801 | 380-10 | 14.961 | + 0 / -0.005 | 11 1/2 | 12.253 | 20 | M24 x 120 | M24 | 620 | 267503 | 311526 | 18.031 | 25.40 | 3.229 | 3.624 | 0.396 | 15.276 | 5/16 | 292 | | | |
| HHC3901 | HHT3901 | 390-10 | 15.354 | + 0 / -0.005 | 12 1/4 | 12.575 | 21 | M24 x 120 | M24 | 620 | 316592 | 336924 | 18.425 | 25.99 | 3.327 | 3.722 | 0.396 | 15.629 | 3/8 | 305 | | | |
| HHC4201 | HHT4201 | 420-10 | 16.535 | + 0 / -0.006 | 12 1/2 | 13.543 | 24 | M24 x 130 | M24 | 620 | 342747 | 414833 | 19.843 | 27.17 | 3.720 | 4.117 | 0.397 | 16.929 | 3/8 | 364 | | | |
| HHC4401 | HHT4401 | 440-10 | 17.323 | + 0 / -0.006 | 13 1/2 | 14.187 | 24 | M24 x 130 | M24 | 620 | 384372 | 426268 | 20.748 | 29.53 | 3.977 | 4.467 | 0.491 | 17.716 | 3/8 | 467 | | | |
| HHC4601 | HHT4601 | 460-10 | 18.110 | + 0 / -0.006 | 14 1/8 | 14.832 | 28 | M24 x 130 | M24 | 620 | 467097 | 525790 | 21.535 | 30.32 | 3.977 | 4.467 | 0.491 | 18.425 | 3/8 | 483 | | | |
| HHC4801 | HHT4801 | 480-10 | 18.898 | + 0 / -0.006 | 14 3/4 | 15.477 | 30 | M24 x 150 | M24 | 620 | 523543 | 588179 | 22.441 | 31.50 | 4.292 | 4.786 | 0.495 | 19.291 | 1/2 | 555 | | | |
| HHC5001 | HHT5001 | 500-10 | 19.685 | + 0 / -0.006 | 15 3/8 | 16.122 | 24 | M27 x 150 | M27 | 922 | 584795 | 655074 | 23.228 | 33.46 | 4.292 | 4.786 | 0.495 | 19.999 | 1/2 | 626 | | | |

| Specifications for Web Clearance Holes (diameter in inches) | | | | | | | | | |
|---|-------|-------|-------|-------|-------|-------|-------|-------|-------|
| Screw Size | M5 | M6 | M8 | M10 | M12 | M16 | M20 | M24 | M27 |
| Split Shrink Disc | 0.281 | 0.328 | 0.406 | 0.500 | 0.594 | 0.750 | 0.906 | 1.063 | 1.188 |
| Half Shrink Disc HT | 0.219 | 0.266 | 0.359 | 0.438 | 0.531 | 0.719 | 0.875 | 1.031 | 1.156 |

Table 1

- Notes:
- Type HT: Screw length must be determined based on your X dimension. Please consult Applications Engineering.
 - Inner rings of all shrink discs are supplied with one lengthwise slit.
 - Shrink discs are available for shafts up to 40" diameter and in a variety of special designs.
 - Maximum shaft sizes listed for Shrink Disc Series SD10 and SD30 reflect equal section moduli of shaft and hub (maximum shaft diameter = $\frac{d}{1.221}$).
 - Larger shrink discs for shafts up to 40" diameter are available on request.

| Shaft Sizes (inch) | | Maximum Diametrical Clearance Between Shaft and Hub Bore |
|--------------------|---------|--|
| > | ≤ | |
| 1 1/8 | 1 15/16 | 0.0010 |
| 1 15/16 | 4 3/4 | 0.0015 |
| 4 3/4 | 7 | 0.0030 |
| 7 | 10 | 0.0040 |
| 10 | 14 | 0.0050 |
| 14 | | 0.0060 |

Table 2
For Series SD10, SD20 and SD30

SD20 – Half SD – Light Duty

| Type HC Part Number | Type HT Part Number | Size | SD bore (Hub OD) | | Shaft Diameter Range | | Locking Screws | | | M _a Install Torque (ft lb) | M _t Max. Transmitted Torque | | A (inch) | D (inch) | L (inch) | H _i (inch) | e (inch) | d ₁ (inch) | R (inch) | Ship wt (lb) |
|---------------------|---------------------|--------|------------------|-----------------------|----------------------|---------------|----------------|-----------|---------|--|---|----------------|----------|----------|----------|-----------------------|----------|-----------------------|----------|--------------|
| | | | d (inch) | T _d (inch) | ds-MIN (inch) | ds-MAX (inch) | Qty | HC Size | HT Size | | ds-MIN (ft lb) | ds-MAX (ft lb) | | | | | | | | |
| | | | | | | | | | | | | | | | | | | | | |
| HHC1252 | HHT1252 | 125-20 | 4.921 | + 0 / -0.004 | 3 5/8 | 4.125 | 8 | M10 x 40 | M10 | 44 | 4690 | 6672 | 6.220 | 7.28 | 0.965 | 1.202 | 0.238 | 5.118 | 1/8 | 7 |
| HHC1402 | HHT1402 | 140-20 | 5.512 | + 0 / -0.004 | 4 1/4 | 5.00 | 9 | M10 x 40 | M10 | 44 | 6846 | 10164 | 6.889 | 8.67 | 0.965 | 1.202 | 0.238 | 5.669 | 1/8 | 10 |
| HHC1552 | HHT1552 | 155-20 | 6.102 | + 0 / -0.004 | 5 | 5.500 | 11 | M10 x 40 | M10 | 44 | 10572 | 13724 | 7.559 | 9.65 | 0.965 | 1.202 | 0.238 | 6.259 | 1/8 | 12 |
| HHC1652 | HHT1652 | 165-20 | 6.496 | + 0 / -0.004 | 5 3/8 | 5.750 | 10 | M12 x 50 | M12 | 74 | 15326 | 18339 | 8.267 | 10.24 | 1.103 | 1.417 | 0.315 | 6.653 | 3/16 | 16 |
| HHC1752 | HHT1752 | 175-20 | 6.890 | + 0 / -0.004 | 5 5/8 | 6.125 | 11 | M12 x 50 | M12 | 74 | 17470 | 21794 | 8.661 | 10.83 | 1.103 | 1.417 | 0.315 | 7.047 | 3/16 | 17 |
| HHC1852 | HHT1852 | 185-20 | 7.283 | + 0 / -0.004 | 6 | 6.500 | 12 | M12 x 50 | M12 | 74 | 20822 | 25518 | 8.858 | 11.62 | 1.103 | 1.417 | 0.315 | 7.440 | 3/16 | 20 |
| HHC1952 | HHT1952 | 195-20 | 7.677 | + 0 / -0.004 | 6 1/2 | 7.000 | 15 | M12 x 60 | M12 | 74 | 29490 | 35537 | 9.330 | 12.40 | 1.299 | 1.617 | 0.318 | 7.834 | 3/16 | 27 |
| HHC2202 | HHT2202 | 220-20 | 8.661 | + 0 / -0.004 | 7 | 7.875 | 10 | M16 x 70 | M16 | 185 | 38227 | 50448 | 10.433 | 13.59 | 1.496 | 1.852 | 0.356 | 8.818 | 3/16 | 37 |
| HHC2402 | HHT2402 | 240-20 | 9.449 | + 0 / -0.004 | 7 7/8 | 8.500 | 12 | M16 x 70 | M16 | 185 | 53506 | 64932 | 11.417 | 14.57 | 1.594 | 1.950 | 0.356 | 9.606 | 1/4 | 42 |
| HHC2602 | HHT2602 | 260-20 | 10.236 | + 0 / -0.004 | 8 5/8 | 9.250 | 14 | M16 x 70 | M16 | 185 | 69970 | 83309 | 12.204 | 15.55 | 1.712 | 2.110 | 0.398 | 10.433 | 1/4 | 51 |
| HHC2802 | HHT2802 | 280-20 | 11.024 | + 0 / -0.005 | 9 | 9.875 | 16 | M16 x 75 | M16 | 185 | 79362 | 100198 | 13.110 | 16.74 | 1.949 | 2.345 | 0.397 | 11.220 | 1/4 | 67 |
| HHC3002 | HHT3002 | 300-20 | 11.811 | + 0 / -0.005 | 9 7/8 | 10.625 | 18 | M16 x 75 | M16 | 185 | 114968 | 135644 | 14.094 | 18.11 | 1.949 | 2.345 | 0.397 | 12.007 | 1/4 | 79 |
| HHC3202 | HHT3202 | 320-20 | 12.598 | + 0 / -0.005 | 10 1/2 | 11.375 | 20 | M16 x 75 | M16 | 185 | 119470 | 146023 | 14.881 | 19.49 | 1.949 | 2.385 | 0.437 | 12.795 | 1/4 | 96 |
| HHC3402 | HHT3402 | 340-20 | 13.386 | + 0 / -0.005 | 11 3/8 | 12.000 | 21 | M16 x 75 | M16 | 185 | 140500 | 160429 | 15.826 | 21.07 | 1.949 | 2.385 | 0.437 | 13.582 | 1/4 | 114 |
| HHC3602 | HHT3602 | 360-20 | 14.173 | + 0 / -0.005 | 11 7/8 | 12.625 | 16 | M20 x 90 | M20 | 362 | 170938 | 199015 | 16.653 | 21.85 | 2.363 | 2.799 | 0.437 | 14.370 | 5/16 | 137 |
| HHC3802 | HHT3802 | 380-20 | 14.961 | + 0 / -0.005 | 12 1/2 | 13.000 | 18 | M20 x 100 | M20 | 362 | 201670 | 222315 | 17.401 | 23.03 | 2.599 | 3.069 | 0.471 | 15.236 | 5/16 | 168 |
| HHC3902 | HHT3902 | 390-20 | 15.354 | + 0 / -0.005 | 12 5/8 | 13.75 | 20 | M20 x 100 | M20 | 362 | 223086 | 274543 | 17.795 | 23.43 | 2.599 | 3.074 | 0.476 | 15.629 | 5/16 | 172 |
| HHC4202 | HHT4202 | 420-20 | 16.535 | + 0 / -0.006 | 13 3/4 | 14.625 | 22 | M20 x 100 | M20 | 362 | 272248 | 312909 | 19.094 | 24.81 | 2.756 | 3.229 | 0.473 | 16.810 | 5/16 | 199 |
| HHC4602 | HHT4602 | 460-20 | 18.110 | + 0 / -0.006 | 14 5/8 | 16.375 | 28 | M20 x 110 | M20 | 362 | 352227 | 463928 | 20.747 | 26.97 | 3.090 | 3.602 | 0.512 | 18.425 | 3/8 | 257 |
| HHC5002 | HHT5002 | 500-20 | 19.685 | + 0 / -0.006 | 16 1/4 | 17.375 | 30 | M20 x 120 | M20 | 362 | 430064 | 507476 | 22.519 | 29.53 | 3.484 | 3.997 | 0.513 | 19.999 | 3/8 | 350 |

SD30 – Half SD – Heavy Duty

| Type HC Part Number | Type HT Part Number | Size | SD bore (Hub OD) | | Shaft Diameter Range | | Locking Screws | | | M _a Install Torque (ft lb) | M _t Max. Transmitted Torque | | A (inch) | D (inch) | L (inch) | H _i (inch) | e (inch) | d ₁ (inch) | R (inch) | Ship wt (lb) |
|---------------------|---------------------|--------|------------------|-----------------------|----------------------|---------------|----------------|-----------|---------|--|---|----------------|----------|----------|----------|-----------------------|----------|-----------------------|----------|--------------|
| | | | d (inch) | T _d (inch) | ds-MIN (inch) | ds-MAX (inch) | Qty | HC Size | HT Size | | ds-MIN (ft lb) | ds-MAX (ft lb) | | | | | | | | |
| | | | | | | | | | | | | | | | | | | | | |
| HHC0443 | HHT0443 | 44-30 | 1.732 | + 0 / -0.002 | 1 1/8 | 1.419 | 5 | M8 x 30 | M8 | 22 | 471 | 827 | 2.598 | 3.35 | 0.649 | 0.768 | 0.119 | 1.890 | 1/16 | 1.2 |
| HHC0503 | HHT0503 | 50-30 | 1.969 | + 0 / -0.002 | 1 3/8 | 1.612 | 7 | M8 x 35 | M8 | 22 | 881 | 1375 | 2.874 | 3.74 | 0.689 | 0.868 | 0.180 | 1.984 | 1/16 | 1.8 |
| HHC0553 | HHT0553 | 55-30 | 2.165 | + 0 / -0.002 | 1 1/2 | 1.773 | 7 | M8 x 35 | M8 | 22 | 946 | 1512 | 3.071 | 4.13 | 0.689 | 0.868 | 0.180 | 2.323 | 3/32 | 2.1 |
| HHC0623 | HHT0623 | 62-30 | 2.441 | + 0 / -0.002 | 1 3/4 | 1.999 | 7 | M8 x 35 | M8 | 22 | 1177 | 1622 | 3.346 | 4.53 | 0.689 | 0.868 | 0.180 | 2.598 | 3/32 | 2.3 |
| HHC0683 | HHT0683 | 68-30 | 2.677 | + 0 / -0.002 | 1 7/8 | 2.193 | 8 | M8 x 35 | M8 | 22 | 1431 | 2087 | 3.622 | 4.72 | 0.689 | 0.868 | 0.180 | 2.835 | 3/32 | 2.5 |
| HHC0753 | HHT0753 | 75-30 | 2.953 | + 0 / -0.002 | 2 1/8 | 2.418 | 7 | M10 x 40 | M10 | 44 | 2276 | 3265 | 4.134 | 5.71 | 0.906 | 1.102 | 0.197 | 3.307 | 1/8 | 4.6 |
| HHC0803 | HHT0803 | 80-30 | 3.150 | + 0 / -0.002 | 2 3/8 | 2.580 | 7 | M10 x 40 | M10 | 44 | 2771 | 3486 | 4.134 | 5.71 | 0.906 | 1.102 | 0.197 | 3.307 | 1/8 | 4.4 |
| HHC0903 | HHT0903 | 90-30 | 3.543 | + 0 / -0.004 | 2 1/2 | 2.902 | 8 | M10 x 40 | M10 | 44 | 2973 | 4497 | 4.567 | 6.30 | 0.985 | 1.182 | 0.198 | 3.701 | 1/8 | 6 |
| HHC1003 | HHT1003 | 100-30 | 3.937 | + 0 / -0.004 | 2 7/8 | 3.224 | 10 | M10 x 45 | M10 | 44 | 4685 | 6350 | 4.961 | 6.69 | 1.063 | 1.262 | 0.199 | 4.094 | 1/8 | 7 |
| HHC1103 | HHT1103 | 110-30 | 4.331 | + 0 / -0.004 | 3 1/8 | 3.547 | 12 | M10 x 45 | M10 | 44 | 6058 | 8440 | 5.354 | 7.28 | 1.182 | 1.377 | 0.196 | 4.482 | 1/8 | 9 |
| HHC1253 | HHT1253 | 125-30 | 4.921 | + 0 / -0.004 | 3 1/2 | 4.031 | 12 | M12 x 50 | M12 | 74 | 10046 | 14197 | 6.299 | 8.47 | 1.260 | 1.497 | 0.237 | 5.157 | 3/16 | 13 |
| HHC1403 | HHT1403 | 140-30 | 5.512 | + 0 / -0.004 | 4 | 4.514 | 12 | M12 x 60 | M12 | 74 | 11638 | 15746 | 6.889 | 9.06 | 1.378 | 1.657 | 0.279 | 5.744 | 3/16 | 16 |
| HHC1553 | HHT1553 | 155-30 | 6.102 | + 0 / -0.004 | 4 1/2 | 4.998 | 15 | M12 x 60 | M12 | 74 | 17077 | 21137 | 7.795 | 10.36 | 1.496 | 1.772 | 0.276 | 6.496 | 3/16 | 23 |
| HHC1653 | HHT1653 | 165-30 | 6.496 | + 0 / -0.004 | 4 7/8 | 5.320 | 10 | M16 x 70 | M16 | 185 | 23479 | 29372 | 8.267 | 11.42 | 1.614 | 1.932 | 0.318 | 6.940 | 3/16 | 32 |
| HHC1753 | HHT1753 | 175-30 | 6.890 | + 0 / -0.004 | 5 1/4 | 5.643 | 10 | M16 x 70 | M16 | 185 | 25902 | 31160 | 8.661 | 11.82 | 1.614 | 1.932 | 0.318 | 7.322 | 3/16 | 33 |
| HHC1853 | HHT1853 | 185-30 | 7.283 | + 0 / -0.004 | 5 5/8 | 5.965 | 15 | M16 x 80 | M16 | 185 | 43424 | 50186 | 9.291 | 12.99 | 2.008 | 2.402 | 0.394 | 7.704 | 3/16 | 53 |
| HHC1953 | HHT1953 | 195-30 | 7.677 | + 0 / -0.004 | 5 7/8 | 6.288 | 15 | M16 x 80 | M16 | 185 | 44744 | 52910 | 9.685 | 13.78 | 2.106 | 2.500 | 0.394 | 8.102 | 1/4 | 60 |
| HHC2003 | HHT2003 | 200-30 | 7.874 | + 0 / -0.004 | 6 1/4 | 6.449 | 15 | M16 x 80 | M16 | 185 | 50233 | 54262 | 9.685 | 13.78 | 2.106 | 2.500 | 0.394 | 8.102 | 1/4 | 59 |
| HHC2203 | HHT2203 | 220-30 | 8.661 | + 0 / -0.004 | 6 3/8 | 7.094 | 20 | M16 x 90 | M16 | 185 | 61729 | 77875 | 10.629 | 14.57 | 2.539 | 2.935 | 0.396 | 8.901 | 1/4 | 76 |
| HHC2403 | HHT2403 | 240-30 | 9.449 | + 0 / -0.004 | 7 | 7.739 | 15 | M20 x 100 | M20 | 362 | 81259 | 100713 | 11.614 | 15.95 | 2.657 | 3.130 | 0.473 | 9.692 | 1/4 | 99 |
| HHC2603 | HHT2603 | 260-30 | 10.236 | + 0 / -0.005 | 7 5/8 | 8.383 | 18 | M20 x 110 | M20 | 362 | 103867 | 131626 | 12.637 | 16.93 | 2.972 | 3.445 | 0.473 | 10.511 | 1/4 | 121 |
| HHC2803 | HHT2803 | 280-30 | 11.024 | + 0 / -0.005 | 8 3/8 | 9.028 | 21 | M20 x 120 | M20 | 362 | 138411 | 166467 | 13.622 | 18.11 | 3.307 | 3.779 | 0.472 | 11.370 | 5/16 | 149 |
| HHC3003 | HHT3003 | 300-30 | 11.811 | + 0 / -0.005 | 9 | 9.673 | 22 | M20 x 120 | M20 | 362 | 156895 | 187186 | 14.330 | 19.10 | 3.386 | 3.859 | 0.473 | 12.177 | 5/16 | 165 |
| HHC3203 | HHT3203 | 320-30 | 12.598 | + 0 / -0.005 | 9 5/8 | 10.318 | 24 | M20 x 120 | M20 | 362 | 184479 | 213912 | 15.196 | 20.48 | 3.544 | 4.019 | 0.476 | 12.964 | 5/16 | 200 |
| HHC3403 | HHT3403 | 340-30 | 13.386 | + 0 / -0.005 | 10 1/4 | 10.963 | 21 | M24 x 130 | M24 | 620 | 244665 | 288982 | 16.535 | 22.44 | 3.859 | 4.334 | 0.476 | 13.724 | 5/16 | 272 |
| HHC3603 | HHT3603 | 360-30 | 14.173 | + 0 / -0.005 | 11 | 11.608 | 22 | M24 x 140 | M24 | 620 | 281430 | 321267 | 17.007 | 23.23 | 4.035 | 4.512 | 0.477 | 14.515 | 3/8 | 286 |
| HHC3903 | HHT3903 | 390-30 | 15.354 | + 0 / -0.005 | 11 5/8 | 12.575 | 24 | M24 x 140 | M24 | 620 | 314475 | 381014 | 18.425 | 25.99 | 4.193 | 4.667 | 0.475 | 15.609 | 3/8 | 384 |
| HHC4203 | HHT4203 | 420-30 | 16.535 | + 0 / -0.006 | 12 1/2 | 13.543 | 30 | M24 x 160 | M24 | 620 | 426421 | 516866 | 19.842 | 27.17 | 4.705 | 5.177 | 0.472 | 16.811 | 3/8 | 462 |
| HHC4603 | HHT4603 | 460-30 | 18.110 | + 0 / -0.006 | 13 5/8 | 14.832 | 28 | M27 x 170 | M27 | 922 | 572280 | 701947 | 21.535 | 30.32 | 5.000 | 5.556 | 0.556 | 18.503 | 1/2 | 624 |
| HHC5003 | HHT5003 | 500-30 | 19.685 | + 0 / -0.006 | 14 7/8 | 16.122 | 32 | M27 x 180 | M27 | 922 | 721680 | 874666 | 23.622 | 33.47 | 5.434 | 5.986 | 0.552 | 19.999 | 1/2 | 838 |

B-LOC® Single Taper Shrink Discs (SD40)

We also offer SD40 Single Taper Shrink Discs as an alternative to SD10, SD20 & SD30 Double Taper Shrink Discs. The SD40 units have the following attributes:

- **External locking device**
- **Simpler two piece design**
- **Integrated removal holes**
- **Provides extremely concentric and well-balanced mechanical interference fit**

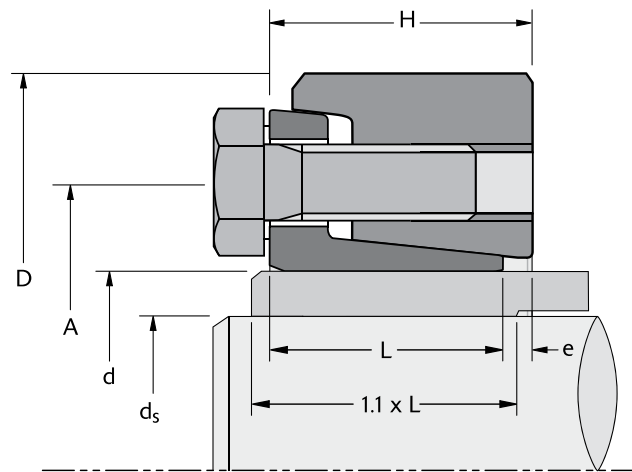

The advantages of the SD40 over the SD10, SD20 and SD30 include:

- No torque wrench needed.* Simply tighten the screws in clockwise sequence, using several passes, until the front faces of the flange and of the outer ring are aligned
- Save up to 80% of mounting time if using a powered tool
- High transmissible torque
- Aligning the two flanges (flush mounted) ensures concentricity, reducing the need for dynamic balancing

Note: Dynamic fit pressures vary between Single Taper and Double Taper shrink discs, as this is based on effective contact length. This should be taken into consideration.

* A torque wrench is recommended for best performance.

For assistance or more information on B-LOC Single Taper Shrink Discs, contact Fenner Drives Applications Engineering group at AE@fennerdrives.com.



Metric hex head locking screws ISO 4017 grade 12.9 (See M_a for install torque.)

| Shaft Sizes (inch) | | Maximum Diametrical Clearance Between Shaft and Hub Bore |
|--------------------|-------|--|
| > | ≤ | |
| 1.18 | 1.97 | 0.0016 |
| 1.97 | 3.15 | 0.0019 |
| 3.15 | 4.72 | 0.0022 |
| 4.72 | 6.30 | 0.0026 |
| 6.30 | 7.09 | 0.0031 |
| 7.09 | 9.84 | 0.0035 |
| 9.84 | 12.40 | 0.0040 |
| 12.40 | 15.75 | 0.0044 |
| 15.75 | 19.69 | 0.0048 |
| 19.69 | 22.05 | 0.0054 |

SD40 – Single Taper

| Part Number | Size | SD bore (Hub OD) | | Hub OD Tolerance | | Shaft Diameter Range | | Locking Screws | | M _a | | M _t | | A (inch) | D (inch) | L (inch) | H (inch) | e (inch) | R (inch) | Ship wt (lb) |
|-------------|--------|------------------|-----------------------|------------------|---------------|----------------------|-----------|------------------------|-------------------------|----------------|----------------|----------------|--------|----------|----------|----------|----------|----------|----------|--------------|
| | | d (inch) | T _d (inch) | ds-MIN (inch) | ds-MAX (inch) | Qty | Size | Install Torque (ft lb) | Max. Transmitted Torque | ds-MIN (ft lb) | ds-MAX (ft lb) | | | | | | | | | |
| | | | | | | | | | | | | | | | | | | | | |
| H0504 | 50-40 | 1.969 | +0.0010/-0.0020 | 1.496 | 1.654 | 8 | M8 x 20 | 25 | 1180 | 1475 | 2.677 | 3.543 | 0.925 | 1.028 | 0.103 | 0.086 | 1.8 | | | |
| H0554 | 55-40 | 2.165 | +0.0012/-0.0024 | 1.654 | 1.890 | 8 | M8 x 20 | 25 | 1254 | 1844 | 2.835 | 3.937 | 1.024 | 1.142 | 0.118 | 0.090 | 2.4 | | | |
| H0604 | 60-40 | 2.362 | +0.0012/-0.0024 | 1.890 | 2.047 | 9 | M8 x 20 | 25 | 1696 | 2139 | 3.150 | 4.331 | 1.024 | 1.152 | 0.128 | 0.094 | 2.9 | | | |
| H0624 | 62-40 | 2.441 | +0.0012/-0.0024 | 1.890 | 2.047 | 9 | M8 x 20 | 25 | 1696 | 2139 | 3.150 | 4.331 | 1.024 | 1.152 | 0.128 | 0.096 | 2.9 | | | |
| H0684 | 68-40 | 2.677 | +0.0012/-0.0024 | 1.969 | 2.362 | 9 | M8 x 20 | 25 | 1770 | 2950 | 3.386 | 4.528 | 1.024 | 1.157 | 0.133 | 0.101 | 2.9 | | | |
| H0754 | 75-40 | 2.953 | +0.0012/-0.0024 | 2.165 | 2.559 | 10 | M10 x 25 | 52 | 2803 | 4426 | 3.937 | 5.433 | 1.063 | 1.209 | 0.146 | 0.106 | 5.1 | | | |
| H0804 | 80-40 | 3.150 | +0.0012/-0.0024 | 2.362 | 2.756 | 10 | M10 x 25 | 52 | 3172 | 4794 | 4.094 | 5.551 | 1.063 | 1.224 | 0.161 | 0.110 | 5.1 | | | |
| H0854 | 85-40 | 3.346 | +0.0014/-0.0028 | 2.559 | 2.953 | 11 | M10 x 25 | 52 | 4426 | 6343 | 4.488 | 6.102 | 1.339 | 1.504 | 0.165 | 0.114 | 7.1 | | | |
| H0904 | 90-40 | 3.543 | +0.0014/-0.0028 | 2.559 | 2.953 | 11 | M10 x 25 | 52 | 4426 | 6343 | 4.488 | 6.102 | 1.339 | 1.504 | 0.165 | 0.119 | 7.1 | | | |
| H0954 | 95-40 | 3.740 | +0.0014/-0.0028 | 2.756 | 3.150 | 14 | M10 x 25 | 52 | 5532 | 7819 | 4.882 | 6.693 | 1.535 | 1.711 | 0.176 | 0.123 | 9.5 | | | |
| H1004 | 100-40 | 3.937 | +0.0014/-0.0028 | 2.756 | 3.150 | 14 | M10 x 25 | 52 | 5532 | 7819 | 4.882 | 6.693 | 1.535 | 1.711 | 0.176 | 0.127 | 9.5 | | | |
| H1054 | 105-40 | 4.134 | +0.0014/-0.0028 | 3.150 | 3.543 | 12 | M12 x 35 | 89 | 9441 | 12539 | 5.354 | 7.283 | 1.713 | 1.933 | 0.220 | 0.131 | 13 | | | |
| H1104 | 110-40 | 4.331 | +0.0014/-0.0028 | 3.150 | 3.543 | 12 | M12 x 35 | 89 | 9441 | 12539 | 5.354 | 7.283 | 1.713 | 1.933 | 0.220 | 0.135 | 13 | | | |
| H1154 | 115-40 | 4.528 | +0.0014/-0.0028 | 3.346 | 3.740 | 14 | M12 x 35 | 89 | 10105 | 13424 | 5.787 | 7.756 | 1.890 | 2.087 | 0.197 | 0.139 | 16 | | | |
| H1204 | 120-40 | 4.724 | +0.0014/-0.0028 | 3.346 | 3.740 | 14 | M12 x 35 | 89 | 10105 | 13424 | 5.787 | 7.756 | 1.890 | 2.087 | 0.197 | 0.143 | 15 | | | |
| H1254 | 125-40 | 4.921 | +0.0017/-0.0033 | 3.543 | 3.937 | 14 | M12 x 35 | 89 | 12244 | 15858 | 6.220 | 8.465 | 1.890 | 2.102 | 0.212 | 0.147 | 19 | | | |
| H1304 | 130-40 | 5.118 | +0.0017/-0.0033 | 3.740 | 4.331 | 12 | M14 x 40 | 140 | 15121 | 21759 | 6.496 | 9.055 | 2.008 | 2.264 | 0.256 | 0.151 | 24 | | | |
| H1354 | 135-40 | 5.315 | +0.0017/-0.0033 | 3.740 | 4.331 | 12 | M14 x 40 | 140 | 15121 | 21759 | 6.496 | 9.055 | 2.008 | 2.264 | 0.256 | 0.155 | 24 | | | |
| H1404 | 140-40 | 5.512 | +0.0017/-0.0033 | 3.937 | 4.528 | 12 | M14 x 40 | 140 | 17334 | 23972 | 6.772 | 9.055 | 2.008 | 2.276 | 0.268 | 0.159 | 23 | | | |
| H1504 | 150-40 | 5.906 | +0.0017/-0.0033 | 4.331 | 4.921 | 14 | M14 x 40 | 140 | 23234 | 31717 | 7.323 | 10.354 | 2.165 | 2.449 | 0.284 | 0.167 | 34 | | | |
| H1554 | 155-40 | 6.102 | +0.0017/-0.0033 | 4.331 | 4.921 | 14 | M14 x 40 | 140 | 23234 | 31717 | 7.323 | 10.354 | 2.165 | 2.449 | 0.284 | 0.171 | 34 | | | |
| H1604 | 160-40 | 6.299 | +0.0017/-0.0033 | 4.724 | 5.315 | 12 | M16 x 45 | 214 | 33192 | 43518 | 7.795 | 11.417 | 2.402 | 2.693 | 0.291 | 0.176 | 49 | | | |
| H1654 | 165-40 | 6.496 | +0.0017/-0.0033 | 4.724 | 5.315 | 12 | M16 x 50 | 214 | 33192 | 43518 | 7.795 | 11.417 | 2.402 | 2.693 | 0.291 | 0.180 | 47 | | | |
| H1704 | 170-40 | 6.693 | +0.0017/-0.0033 | 5.118 | 5.709 | 14 | M16 x 50 | 214 | 40568 | 52370 | 8.189 | 11.811 | 2.402 | 2.713 | 0.311 | 0.184 | 51 | | | |
| H1754 | 175-40 | 6.890 | +0.0017/-0.0033 | 5.118 | 5.709 | 14 | M16 x 50 | 214 | 40568 | 52370 | 8.189 | 11.811 | 2.402 | 2.713 | 0.311 | 0.188 | 50 | | | |
| H1804 | 180-40 | 7.087 | +0.0017/-0.0033 | 5.512 | 6.102 | 16 | M16 x 50 | 214 | 59746 | 74498 | 8.740 | 12.598 | 3.051 | 3.346 | 0.295 | 0.192 | 74 | | | |
| H1854 | 185-40 | 7.283 | +0.0020/-0.0038 | 5.512 | 6.102 | 16 | M16 x 50 | 214 | 59746 | 74498 | 8.740 | 12.598 | 3.051 | 3.346 | 0.295 | 0.196 | 72 | | | |
| H1904 | 190-40 | 7.480 | +0.0020/-0.0038 | 5.906 | 6.496 | 16 | M16 x 50 | 214 | 71547 | 88512 | 9.370 | 13.386 | 3.051 | 3.453 | 0.402 | 0.200 | 84 | | | |
| H1954 | 195-40 | 7.677 | +0.0020/-0.0038 | 5.906 | 6.496 | 16 | M16 x 50 | 214 | 71547 | 88512 | 9.370 | 13.386 | 3.051 | 3.453 | 0.402 | 0.204 | 82 | | | |
| H2004 | 200-40 | 7.874 | +0.0020/-0.0038 | 5.906 | 6.496 | 16 | M16 x 50 | 214 | 71547 | 88512 | 9.370 | 13.386 | 3.051 | 3.453 | 0.402 | 0.208 | 80 | | | |
| H2204 | 220-40 | 8.661 | +0.0020/-0.0038 | 6.299 | 7.087 | 15 | M20 x 60 | 420 | 95888 | 125392 | 10.551 | 14.567 | 3.799 | 4.234 | 0.435 | 0.224 | 117 | | | |
| H2404 | 240-40 | 9.449 | +0.0020/-0.0038 | 6.693 | 7.874 | 16 | M20 x 60 | 420 | 112115 | 161534 | 11.339 | 15.945 | 3.858 | 4.374 | 0.516 | 0.241 | 146 | | | |
| H2604 | 260-40 | 10.236 | +0.0022/-0.0043 | 7.480 | 8.661 | 16 | M20 x 60 | 420 | 158584 | 221280 | 12.283 | 16.929 | 4.350 | 4.933 | 0.583 | 0.257 | 181 | | | |
| H2804 | 280-40 | 11.024 | +0.0022/-0.0043 | 8.268 | 9.449 | 18 | M20 x 60 | 420 | 208003 | 280288 | 13.150 | 18.110 | 4.764 | 5.512 | 0.748 | 0.273 | 227 | | | |
| H3004 | 300-40 | 11.811 | +0.0022/-0.0043 | 8.661 | 9.843 | 16 | M24 x 70 | 730 | 269224 | 359211 | 14.173 | 19.094 | 4.882 | 5.504 | 0.622 | 0.290 | 265 | | | |
| H3204 | 320-40 | 12.598 | +0.0024/-0.0047 | 9.449 | 10.630 | 18 | M24 x 70 | 730 | 327494 | 427808 | 14.961 | 20.472 | 4.882 | 5.575 | 0.693 | 0.306 | 304 | | | |
| H3404 | 340-40 | 13.386 | +0.0024/-0.0047 | 9.843 | 11.024 | 18 | M24 x 70 | 730 | 395354 | 511157 | 15.827 | 22.441 | 5.472 | 6.236 | 0.764 | 0.322 | 417 | | | |
| H3604 | 360-40 | 14.173 | +0.0024/-0.0047 | 10.630 | 11.417 | 20 | M24 x 70 | 730 | 506731 | 612208 | 16.693 | 23.228 | 5.630 | 6.417 | 0.787 | 0.339 | 456 | | | |
| H3904 | 390-40 | 15.354 | +0.0024/-0.0047 | 11.417 | 12.598 | 18 | M27 x 70 | 1092 | 633598 | 787757 | 17.874 | 25.591 | 5.827 | 6.661 | 0.834 | 0.363 | 549 | | | |
| H4204 | 420-40 | 16.535 | +0.0027/-0.0052 | 12.598 | 13.780 | 20 | M27 x 70 | 1092 | 785544 | 959618 | 19.134 | 26.378 | 6.535 | 7.323 | 0.788 | 0.387 | 628 | | | |
| H4404 | 440-40 | 17.323 | +0.0027/-0.0052 | 13.386 | 14.567 | 21 | M27 x 70 | 1092 | 983221 | 1184586 | 19.921 | 29.134 | 6.772 | 7.634 | 0.862 | 0.404 | 866 | | | |
| H4604 | 460-40 | 18.110 | +0.0027/-0.0052 | 14.173 | 15.354 | 21 | M27 x 70 | 1092 | 1130003 | 1346858 | 21.024 | 30.315 | 7.008 | 7.992 | 0.984 | 0.420 | 924 | | | |
| H4704 | 470-40 | 18.504 | +0.0027/-0.0052 | 14.567 | 15.748 | 21 | M27 x 70 | 1092 | 811360 | 1032640 | 21.181 | 27.756 | 7.874 | 8.646 | 0.772 | 0.428 | 750 | | | |
| H4804 | 480-40 | 18.898 | +0.0027/-0.0052 | 14.961 | 16.142 | 21 | M30 x 100 | 1460 | 1343907 | 1586578 | 21.732 | 31.496 | 8.228 | 9.161 | 0.933 | 0.436 | 1085 | | | |
| H5004 | 500-40 | 19.685 | +0.0027/-0.0052 | 15.748 | 16.929 | 24 | M30 x 100 | 1460 | 1530520 | 1793843 | 23.937 | 33.465 | 7.795 | 8.685 | 0.890 | 0.453 | 1250 | | | |
| H5304 | 530-40 | 20.866 | +0.0030/-0.0057 | 16.929 | 18.110 | 24 | M30 x 100 | 1460 | 1548960 | 1792368 | 23.937 | 33.465 | 8.504 | 9.539 | 1.035 | 0.477 | 1162 | | | |
| H5604 | 560-40 | 22.047 | +0.0030/-0.0057 | 17.717 | 18.898 | 24 | M30 x 100 | 1460 | 2064542 | 2377285 | 24.882 | 37.008 | 8.661 | 9.630 | 0.969 | 0.502 | 1711 | | | |
| H5904 | 590-40 | 23.228 | +0.0030/-0.0057 | 18.504 | 19.685 | 28 | M30 x 100 | 1460 | 2408264 | 2755674 | 26.142 | 37.795 | 9.291 | 10.260 | 0.969 | 0.526 | 1841 | | | |
| H6204 | 620-40 | 24.409 | +0.0030/-0.0057 | 19.685 | 21.260 | 28 | M30 x 100 | 1460 | 2760099 | 3267568 | 27.795 | 38.189 | 10.197 | 11.378 | 1.181 | 0.550 | 2346 | | | |

DESIGN FEATURES

External locking devices for keyless frictional shaft/hub connections on shafts from 5/8" to 40" diameter, B-LOC® Shrink Discs...

- Provide a high capacity interference fit with all the positive features of conventional interference fits, but without their assembly and disassembly problems.
- Offer extremely concentric and well-balanced connections, ideal for high-speed applications.
- Permit simple axial positioning and angular timing.
- Are available in standard, light, and heavy-duty series to suit any application.

WORKING PRINCIPLE

B-LOC Shrink Discs provide a high-ratio conversion of screw clamp loads into radial contact pressures when the tapered collars are pulled together by tightening of the integrated high-strength locking screws. These radial contact pressures in turn accomplish the following:

1. Contract the inner ring and hub to close the clearance between shaft and hub bore.
2. Generate a defined shaft/hub contact pressure for a high capacity mechanical interference fit.

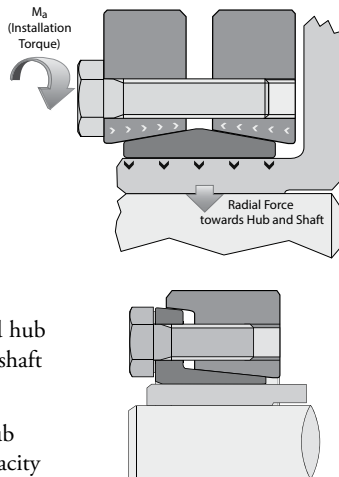

This frictional bond transmits torque, bending and/or thrust loads directly from the hub to the shaft; the shrink disc itself does not carry any torque or thrust load.

TORQUE

M_t = rated torque capacity of one B-LOC Shrink Disc with all screws tightened to specified torque M_a as listed in specifications, based on a coefficient of friction $\mu = 0.15$ and specified tolerances and clearances. Torque capacities for Half Shrink Discs = $\frac{M_t}{2}$

- Torque capacities for connections using shaft diameters between the minimum and maximum sizes listed can be approximated through interpolation.
- Transmissible torque decreases if tolerances and/or clearances are larger than specified; or if hollow shafts with bores exceeding approximately 35% of shaft diameter are used.

THRUST

T_h = transmissible thrust, determined by using the following equation:

$$T_h = \frac{2 \times M_t}{d}$$

where: d = shaft diameter
 M_t = rated torque capacity

TORQUE AND THRUST COMBINED

Simultaneous transmission of torque and thrust requires calculating a resultant torque:

$$M_{t_{res}} = \sqrt{T^2 + \left(\frac{F \times d}{2}\right)^2}$$

where: T = peak drive torque
 F = peak thrust load
 d = shaft diameter

Select a unit where $M_t \geq M_{t_{res}}$

BENDING MOMENTS

Shrink discs will generally transmit a continuous bending moment equal to 25% of rated torque capacity M_t .

RELEASABILITY

Since the tapers of a B-LOC Shrink Disc are self-releasing and stresses from radial contractions of the hub are well within elastic limits, loosening the locking screws results in hub expansion back to its original dimensions, thereby restoring fit clearance for simple disassembly. The SD40 is manufactured with self-releasing tapers, however, it is possible the outer ring may need disengaging from the inner ring. This can be easily done by loosening the bolts in sequence, transferring the appropriate number of bolts over to the threaded back-off holes in the face of the shrink disc and progressively tightening these bolts until the shrink disc becomes loose. The hub and shaft will return to their original fit clearances.

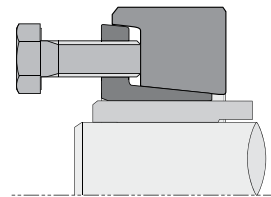

MATERIAL

Shrink disc inner rings are manufactured from high-carbon steel. Outer rings are made from forged and heat treated alloy steel.

LUBRICANTS

Shrink discs are supplied with Molybdenum Disulphide based lubricant applied to the tapers and to the locking screw threads and head contact areas.

SHAFT AND HUB MATERIAL

Listed specifications assume shaft and hub material with a yield point of at least 45 ksi (310 N/mm²). Cast iron hubs are well suited for compressive stresses exerted by B-LOC Shrink Discs. However, a lower torsional hub strength generally requires the selection of a shrink disc at least one size larger than listed if full torque (i.e., that applicable to a steel hub) is to be transmitted.

LENGTH OF FIT

The most recent research on length of fit for a shrink disc connection* indicates that the hub bore-to-shaft interface should be relieved using a non-toleranced clearance except for that portion directly under the shrink disc inner ring, for a fit length equal to "L" for a standard shrink disc (see illustration at right). This approach eliminates fretting corrosion between shaft and hub which can make the separation of components difficult.

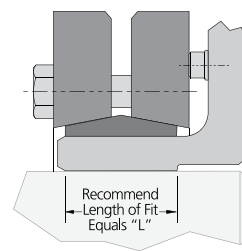

* (see Casper, Thomas: Reibkorrosionsverhalten von Spanelementverbindungen - Aachen: Mainz, 1999)

LOCATING AGAINST HUB FACE

In applications subjected to reversing bending moments, we recommend the configuration at right which requires a hub undercut where $R \geq e$ for smooth transition.

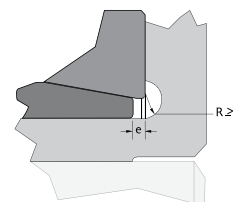



TOLERANCE (T_L)
 $T_L = .003"$ for shafts up to 1"
 $.006"$ for shafts over 1"
 $d =$ Shaft diameter machined to $d+0/-T_L$

Metric hex head locking screws grade 10.9. (See M_a for install torque.)

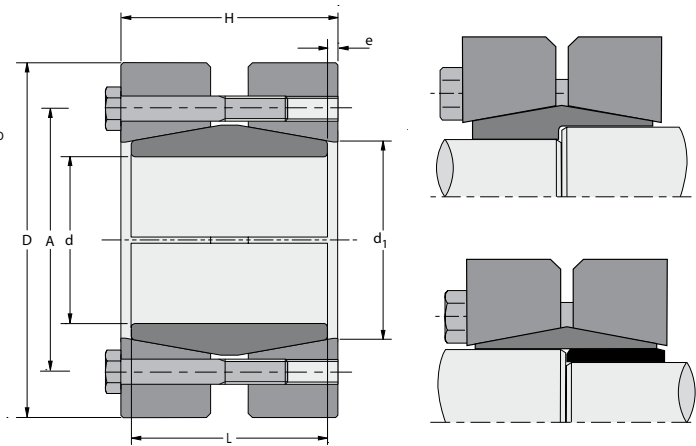

Shaft engagement equal for both ends with gap not exceeding 5% of shaft diameter.

WK Couplings can be manufactured to accommodate different shaft diameters; this can also be accomplished using an adaptor sleeve.

WK Series

| Part Number | Type | d (in) | D (in) | H (in) | L (in) | e (in) | d ₁ (in) | A (in) | Locking Screws | | M _a Install Torque (ft lb) | M _t Maximum Transmissible Torque (ft lb) | Ship wt (lb) |
|-------------|--------|---------|--------|--------|--------|--------|---------------------|--------|----------------|----------|--|--|--------------|
| | | | | | | | | | Qty | Size | | | |
| HWK0152010 | WK 15 | 5/8 | 2.047 | 1.339 | 1.181 | 0.079 | 0.827 | 1.378 | 3 | M6 x 30 | 8.7 | 132 | 0.9 |
| HWK0152011 | | 11/16 | | | | | | | | | | 145 | 0.9 |
| HWK0152012 | | 3/4 | | | | | | | | | | 158 | 0.9 |
| HWK0202013 | WK 20 | 13/16 | 2.362 | 1.575 | 1.339 | 0.118 | 1.024 | 1.614 | 5 | M6 x 35 | 8.7 | 286 | 1.4 |
| HWK0202014 | | 7/8 | | | | | | | | | | 308 | 1.3 |
| HWK0202015 | | 15/16 | | | | | | | | | | 330 | 1.3 |
| HWK0252100 | WK 25 | 1 | 2.598 | 1.732 | 1.496 | 0.118 | 1.260 | 1.890 | 7 | M6 x 35 | 8.7 | 492 | 1.8 |
| HWK0252101 | | 1 1/16 | | | | | | | | | | 523 | 1.8 |
| HWK0252102 | | 1 1/8 | | | | | | | | | | 554 | 1.7 |
| HWK0302103 | WK 30 | 1 3/16 | 2.992 | 1.890 | 1.654 | 0.118 | 1.496 | 2.126 | 8 | M6 x 40 | 8.7 | 668 | 2.7 |
| HWK0302104 | | 1 1/4 | | | | | | | | | | 703 | 2.7 |
| HWK0302106 | | 1 3/8 | | | | | | | | | | 774 | 2.6 |
| HWK0402107 | WK 40 | 1 7/16 | 3.780 | 2.205 | 1.969 | 0.118 | 1.850 | 2.638 | 7 | M8 x 45 | 22 | 1371 | 5 |
| HWK0402108 | | 1 1/2 | | | | | | | | | | 1430 | 5 |
| HWK0402110 | | 1 5/8 | | | | | | | | | | 1550 | 5 |
| HWK0402111 | | 1 11/16 | | | | | | | | | | 1609 | 5 |
| HWK0402112 | | 1 3/4 | | | | | | | | | | 1669 | 5 |
| HWK0502114 | WK 50 | 1 7/8 | 4.409 | 2.676 | 2.362 | 0.157 | 2.283 | 3.150 | 10 | M8 x 50 | 22 | 2554 | 8 |
| HWK0502115 | | 1 15/16 | | | | | | | | | | 2639 | 8 |
| HWK0502200 | | 2 | | | | | | | | | | 2724 | 8 |
| HWK0502202 | | 2 1/8 | | | | | | | | | | 2895 | 8 |
| HWK0602203 | WK 60 | 2 3/16 | 4.724 | 3.071 | 2.756 | 0.157 | 2.598 | 3.504 | 12 | M8 x 55 | 22 | 3576 | 10 |
| HWK0602204 | | 2 1/4 | | | | | | | | | | 3678 | 10 |
| HWK0602206 | | 2 3/8 | | | | | | | | | | 3882 | 10 |
| HWK0602207 | | 2 7/16 | | | | | | | | | | 3984 | 10 |
| HWK0602208 | | 2 1/2 | | | | | | | | | | 4087 | 9 |
| HWK0702209 | WK 70 | 2 9/16 | 5.826 | 3.464 | 3.150 | 0.157 | 3.110 | 4.173 | 12 | M10 x 65 | 44 | 6642 | 19 |
| HWK0702210 | | 2 5/8 | | | | | | | | | | 6804 | 19 |
| HWK0702211 | | 2 11/16 | | | | | | | | | | 6966 | 18 |
| HWK0702212 | | 2 3/4 | | | | | | | | | | 7128 | 18 |
| HWK0702214 | | 2 7/8 | | | | | | | | | | 7452 | 17 |
| HWK0802215 | WK 80 | 2 15/16 | 6.693 | 4.095 | 3.701 | 0.197 | 3.701 | 4.961 | 10 | M12 x 80 | 74 | 9128 | 28 |
| HWK0802300 | | 3 | | | | | | | | | | 9323 | 28 |
| HWK0802302 | | 3 1/8 | | | | | | | | | | 9711 | 27 |
| HWK0802304 | | 3 1/4 | | | | | | | | | | 10099 | 26 |
| HWK0802306 | | 3 3/8 | | | | | | | | | | 10488 | 26 |
| HWK0902307 | WK 90 | 3 7/16 | 7.283 | 4.567 | 4.173 | 0.197 | 4.094 | 5.433 | 12 | M12 x 80 | 74 | 12819 | 36 |
| HWK0902308 | | 3 1/2 | | | | | | | | | | 13052 | 36 |
| HWK0902310 | | 3 5/8 | | | | | | | | | | 13518 | 35 |
| HWK0902312 | | 3 3/4 | | | | | | | | | | 13984 | 34 |
| HWK0902314 | | 3 7/8 | | | | | | | | | | 14450 | 34 |
| HWK1002315 | WK 100 | 3 15/16 | 7.756 | 4.960 | 4.488 | 0.236 | 4.488 | 5.866 | 15 | M12 x 90 | 74 | 18354 | 43 |
| HWK1002400 | | 4 | | | | | | | | | | 18645 | 43 |
| HWK1002404 | | 4 1/4 | | | | | | | | | | 19810 | 42 |

If your application requires increased torque transmission and/or thrust, solvent clean the interface between the bore of the WK unit and the shaft to produce an oil free connection. This in turn will result in up to a 20% increase in M_t and T_H performance values. Contact Fenner Drives Applications Engineering for additional details at AE@fennerdrives.com.

DESIGN FEATURES

External keyless locking devices that simultaneously transmit high torques and bending moments that allow your drive to be overhung shaft mounted.

- Keyless, rigid, zero backlash coupling.
- Transmits high torque and bending moments.
- Eliminates the need for costly mounting brackets and structural support.
- Compact, double taper design with self-releasing tapers for easy removal.
- Exceptional concentricity.
- Installs right over existing keyways and splines.
- Not affected by shock or reversing loads.

WORKING PRINCIPLE

Drawing the two tapered collars together with the integrated tightening screws, generates radial forces that squeeze the inner ring tightly to the two shafts. The inner ring acts as a press fit sleeve, transmitting torque, thrust, and even bending loads from one shaft to the other.

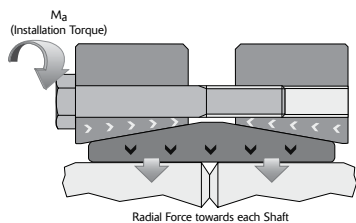

TORQUE

M_t = rated torque capacity of one B-LOC® WK Coupling with all screws tightened to specified torque M_a as listed in specifications.

THRUST

T_h = transmissible thrust, determined by using the following equation:

$$T_h = \frac{2 \times M_t}{d} \quad \text{where: } d = \text{shaft diameter}$$

$$M_t = \text{rated torque capacity}$$

TORQUE AND THRUST COMBINED

Simultaneous transmission of torque and thrust requires calculating a resultant torque:

$$M_{t_{res}} = \sqrt{T^2 + \left(\frac{F \times d}{2}\right)^2} \quad \text{where: } T = \text{peak drive torque}$$

$$F = \text{peak thrust load}$$

$$d = \text{shaft diameter}$$

Select a unit where $M_t \geq M_{t_{res}}$

BENDING MOMENTS

WK Couplings will generally transmit a continuous bending moment equal to 25% of rated torque capacity M_t .

RELEASABILITY

Since the tapers of a B-LOC WK Coupling are self-releasing, loosening the locking screws results in releasing the shafts from the coupling. Care needs to be used by loosening each screw gradually such that the screw tension remains relatively equal on all screws.

MATERIAL

WK Coupling inner rings are manufactured from high-carbon steel. Outer rings are made from forged and heat treated alloy steel.

LUBRICANTS

WK Couplings are supplied with molybdenum disulphide based lubricant applied to the tapers and to the locking screw threads and head contact areas. The bore of WK Couplings are supplied lightly oiled and should only be used with oil supplied on the unit.

SHAFT AND HUB MATERIAL

Listed specifications assume shaft material with a yield point of at least 45 ksi (310 N/mm²).

LENGTH OF FIT

Shaft engagement inside the WK Coupling must be equal for both shafts and the gap between the shafts should not exceed 5% of the shaft diameter.

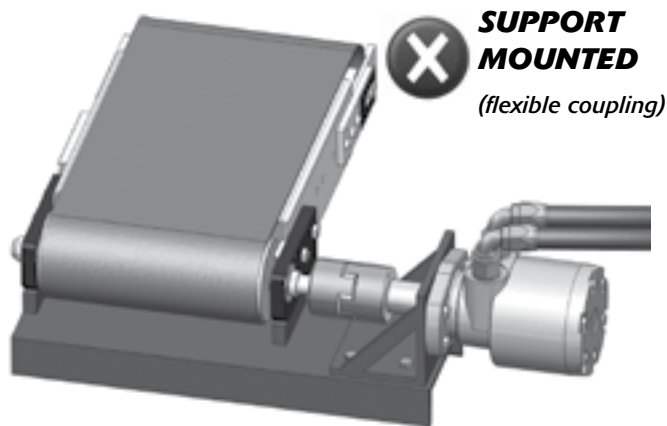

- ❌ Requires bulky frame work and supports
- ❌ Shaft misalignment issues necessitate the use of flexible couplings
- ❌ Fretted and corroded flexible couplings complicate disassembly
- ❌ Higher total cost

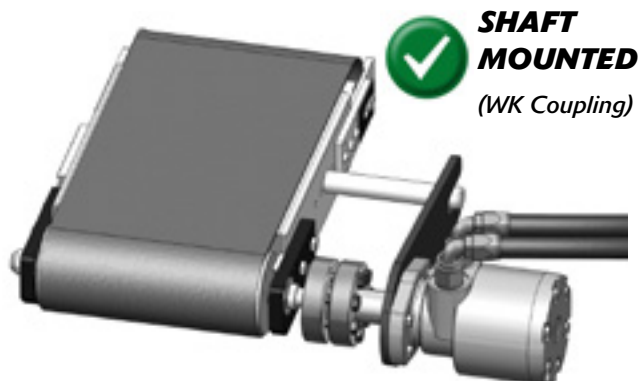

- ✅ Shaft mount completely eliminates shaft misalignment and frame work
- ✅ Simple torque arm prevents motor rotation
- ✅ Keyless mechanical shrink fit never corrodes to the shaft and disassembles easily
- ✅ Compact design allows for smaller drive footprint
- ✅ Lower overall cost

Plan View

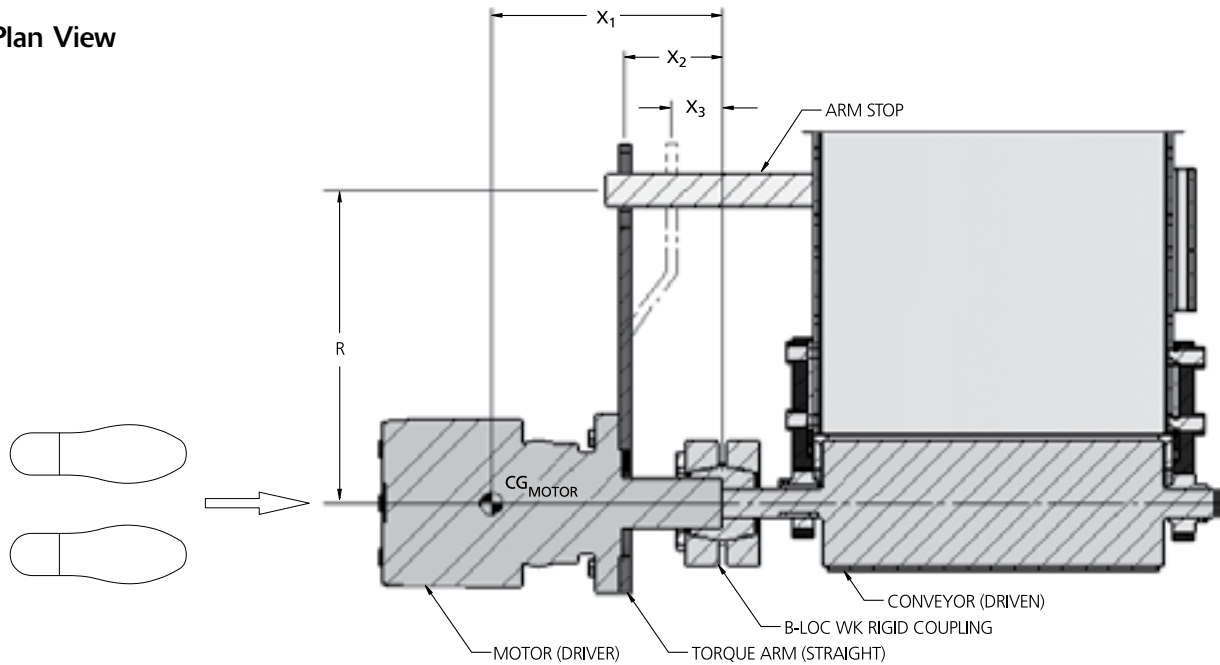

CALCULATIONS

Once you have selected your WK Rigid Coupling, apply the following calculations to verify that it is suitable for your application. Please reference Plan View above.

1. M_t = published max rated torque capacity of B-LOC® WK Rigid Coupling = _____ ft-lb
2. $M_{D_{MAX}}$ = maximum drive torque (stall torque where applicable) = _____ ft-lb
3. W = weight of the overhung shaft mounted drive = _____ lb
4. R = length of the torque arm = _____ ft
5. F_{TA} = torque arm reaction force = $M_{D_{MAX}} \div R$ = _____ lb
6. M_b = bending moment at the coupling
NOTE: M_b must be $< 0.25 \times M_t$

TORQUE ARM OPTIONS

Straight Torque Arm

$$M_b = (W \times X_1) + (F_{TA} \times X_2) = \text{_____ ft-lb}$$

Bent Torque Arm

$$M_b = (W \times X_1) + (F_{TA} \times X_3) = \text{_____ ft-lb}$$

Double Torque Arm

$$M_b = (W \times X_1) = \text{_____ ft-lb}$$

7. M_{bR} = resultant (torque & bending) = $\sqrt{(M_{D_{MAX}})^2 + (2 \times M_b)^2} = \text{_____ ft-lb}$
NOTE: M_{bR} must be $< M_t$

8. If the NOTES in steps 6 and 7 are both satisfied, the B-LOC WK Rigid Coupling is recommended for your application.

The calculations on this page assume worst case placement of torque arm.

To optimize design contact a Fenner Drives Applications Engineer at AE@fennerdrives.com.

DESIGN TIPS

- For any WK Coupling design or engineering questions, contact a Fenner Drives Applications Engineer at AE@fennerdrives.com.
- Shaft mounting creates bending moments in the system; coupling, shafts, bearings etc., must be designed to handle these bending moments.
- Torque arm design and placement can be used to counteract or minimize bending moments in the system.
- Torque arm and arm stop(s) must be adequately designed to handle the forces generated by the motor.
- To achieve up to a 20% increase in coupling load capacity, using a non-petroleum based solvent, clean the shafts and coupling bore to produce a completely lubricant free interface.
- WK Couplings can typically join shafts of different sizes up to a ratio of 2:1. For shaft ratios greater than this, please contact a Fenner Drives Applications Engineer.
- WK Couplings are not recommended for applications in which motor and driven component are rigidly mounted.

POWERMAX COMPOSITE SOLUTIONS



PowerMax™

The PowerMax Advantage

Fenner Drives is the industry leader in molded composite solutions for industrial power transmission and material handling applications. PowerMax composite products are used where dependability counts most.

- High-strength glass reinforced composite idlers and pulleys are available in a wide range of sizes for flat, round and V-belts.
- Our composite products are a lightweight, corrosion resistant alternative to steel, aluminum and cast iron.



PowerMax V-Belt Idlers used with PowerTwist Roller Drive on a Live Roller Conveyor.



Wood panel conveyor using PowerMax Round Idlers and Eagle Red 90 belting.

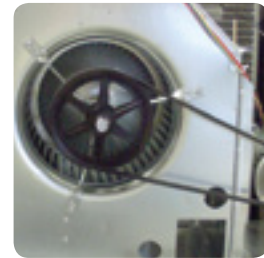

PowerMax DriveN Pulley on a Centrifugal Fan.

Need a custom solution?

With industry leading engineering, Fenner Drives will design the best product for your application.

- In-house modular tooling capabilities allow us to economically build tooling and cut weeks off order lead time.
- Engineered composite material allows for design flexibility by consolidating multiple pieces into one unit.
- We offer a range of engineered composite material to best fit your application requirements.



Timing pulley with overmolded shaft for fitness equipment



Custom molded composite assembly for a bowling ball return wheel



Custom flanged bearing spindle assembly for a floor polisher

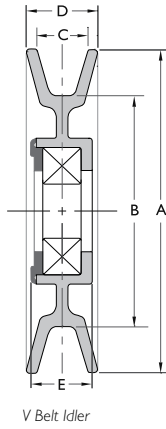

PowerMax™ V Belt Idlers

| Part Number | Type | Grooves | Dimensions (inches) | | | | | Belt Size | Bearing Type | Bore Sizes |
|-------------|------|---------|---------------------|------|------|------|------|-----------|--------------|------------|
| | | | A | B | C | D | E | | | |
| VA3001† | 1 | 1 | 3 | 2 | 0.5 | 0.7 | 0.81 | A | 6203-2RS | 17mm |
| VA3002 | 1 | 1 | 3.1 | 1.84 | 0.63 | 0.78 | 0.81 | B | 6203-2RS | 17mm |
| VA4001 | 1 | 1 | 3.98 | 2.99 | 0.5 | 0.7 | 0.81 | A | 6203-2RS | 17mm |
| VA4002 | 1 | 1 | 4 | 2.84 | 0.64 | 0.86 | 0.81 | B | 6203-2RS | 17mm |
| VA5001 | 1 | 1 | 5.04 | 3.84 | 0.65 | 0.8 | 0.82 | B | 6203-2RS | 17mm |
| VA6001 | 1 | 1 | 6.03 | 5.12 | 0.5 | 0.72 | 0.81 | A | 6203-2RS | 17mm |
| VA6250† | 1 | 1 | 6.25 | 5 | 0.61 | 0.95 | 0.72 | A/B | 6203-2RS | 17mm |
| VA7501 | 1 | 1 | 7.5 | 6.6 | 0.54 | 0.72 | 0.75 | A | 6203-2RS | 17mm |
| V2B6280 | 2 | 2 | 6.28 | 5.18 | 0.64 | 1.72 | 1.85 | B/5V | 6203-2RS | .510/.520 |
| V3B6280 | 2 | 3 | 6.28 | 5.18 | 0.64 | 2.44 | 2.58 | B/5V | 6203-2RS | .510/.520 |
| V4B6280 | 2 | 4 | 6.28 | 5.18 | 0.64 | 3.16 | 3.33 | B/5V | 6203-2RS | .510/.520 |

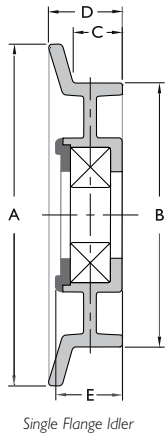

PowerMax Single Flange Belt Idlers

| Part Number | Dimensions (inches) | | | | | Belt Size | Bearing Type | Bore Sizes |
|-------------|---------------------|------|------|------|------|-----------|--------------|------------|
| | A | B | C | D | E | | | |
| VA3600 | 3.6 | 2.84 | 0.59 | 0.84 | 0.8 | B | 6203-2RS | 17mm |
| VA4130* | 4.13 | 3.23 | 0.58 | 0.86 | 0.81 | B | 6203-2RS | 17mm |

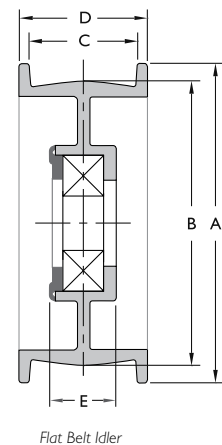

PowerMax Flat Belt Idlers

| Part Number | Type | Crown | Dimensions (inches) | | | | | Belt Size | Bearing Type | Bore Size |
|-------------|------|-------|---------------------|------|------|------|------|-----------|--------------|-----------|
| | | | A | B | C | D | E | | | |
| FA2001† | 1 | Yes | 2.07 | 1.88 | 1.37 | 1.54 | 0.47 | 1 1/8" | 6203-2RS | 17mm |
| FA2002† | 1 | Yes | 2.35 | 1.99 | 0.98 | 1.15 | 0.47 | 7/8" | 6203-2RS | 17mm |
| FA2003 | 1 | No | 2.76 | 1.94 | 0.82 | 1.15 | 0.75 | 5/8" | 6203-2RS | 17mm |
| FA2501† | 1 | No | 2.48 | 1.97 | 1.55 | 1.85 | 0.72 | 11/4" | 6203-2RS | 17mm |
| FA2750† | 1 | Yes | 2.75 | 1.97 | 1.09 | 1.4 | 0.67 | 29/32" | 6203-2RS | 17mm |
| FA2751 | 1 | Yes | 2.75 | 2.52 | 1 | 1.22 | 0.8 | 13/16" | 6203-2RS | 17mm |
| FA3002 | 1 | Yes | 3 | 2.5 | 1.02 | 1.31 | 0.76 | 7/8" | 6203-2RS | 17mm |
| FA3251† | 1 | Yes | 3.24 | 2.97 | 1.04 | 1.2 | 0.67 | 7/8" | 6203-2DD | 17mm |
| FA3301† | 1 | Yes | 3.38 | 2.97 | 1.38 | 1.67 | 0.78 | 11/8" | 6203-2RS | 17mm |
| FA3501 | 1 | Yes | 3.5 | 3 | 0.77 | 1.09 | 0.76 | 5/8" | 6203-2RS | 17mm |
| FA3502 | 1 | Yes | 3.5 | 3 | 1 | 1.22 | 0.76 | 13/16" | 6203-2RS | 17mm |
| FA3504 | 1 | Yes | 3.48 | 2.98 | 0.69 | 0.9 | 0.76 | 1/2" | 6203-2RS | 17mm |
| FA3750† | 1 | Yes | 3.75 | 2.96 | 1.09 | 1.38 | 0.67 | 29/32" | 6203-2RS | 17mm |
| FA3751† | 1 | Yes | 3.8 | 3.25 | 1.03 | 1.24 | 0.67 | 7/8" | 6203-2RS | 17mm |
| FA4501 | 1 | Yes | 4.5 | 4 | 1.09 | 1.39 | 0.76 | 29/32" | 6203-2RS | 17mm |
| FA4750† | 1 | Yes | 4.75 | 3.96 | 1.09 | 1.38 | 0.67 | 29/32" | 6203-2RS | 17mm |
| FA5501† | 1 | Yes | 5.56 | 5.03 | 1.02 | 1.29 | 0.72 | 7/8" | 6203-2RS | 17mm |
| FX0001‡ | 1 | Yes | 2.75 | 2.37 | 1.07 | 1.39 | — | 29/32" | 6205-2RS | 1" |
| F1B6280 | 2 | No | 6.28 | 6 | 1.22 | 1.63 | 1.63 | 1" | 6203-2RS | .510/.520 |
| F2B6280 | 2 | No | 6.28 | 6 | 2.1 | 2.5 | 2.5 | 2" | 6203-2RS | .510/.520 |
| F3B6280 | 2 | No | 6.28 | 6 | 2.91 | 3.31 | 3.31 | 2 3/4" | 6203-2RS | .510/.520 |
| F4B6280 | 2 | No | 6.28 | 6 | 3.85 | 4.25 | 4.25 | 3 3/4" | 6203-2RS | .510/.520 |

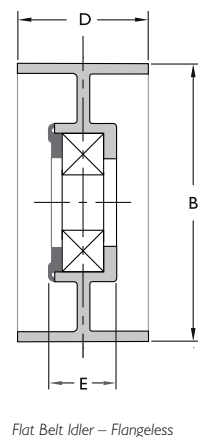

PowerMax Flat Belt Idlers (Flangeless)

| Part Number | Type | Crown | Dimensions (inches) | | | | | Belt Size | Bearing Type | Bore Size |
|-------------|------|-------|---------------------|------|---|------|------|-----------|--------------|-----------|
| | | | A | B | C | D | E | | | |
| FA2009† | 1 | No | — | 2 | — | 1 | 0.47 | 13/16" | 6203-2RS | 17mm |
| FA2010† | 1 | No | — | 1.98 | — | 0.75 | 0.47 | 5/8" | 6203-2DD | 17mm |
| FA2700† | 1 | No | — | 2.71 | — | 1.05 | 0.67 | 7/8" | 6203-2RS | 17mm |
| FA2900* | 1 | Yes | — | 2.91 | — | 1.22 | 0.76 | 1" | 6203-2RS | 17mm |
| FA3003* | 1 | No | — | 2.96 | — | 1.09 | 0.76 | 29/32" | 6203-2RS | 17mm |
| FA3250† | 1 | No | — | 3.2 | — | 1.01 | 0.67 | 13/16" | 6203-2DD | 17mm |
| FA4502 | 1 | No | — | 4.5 | — | 1.21 | 0.82 | 1" | 6203-2RS | 17mm |
| FX0002‡ | 1 | Yes | — | 2.33 | — | 1.39 | — | 11/8" | 6205-2RS | 1" |

* Minimums may apply.

† Insertion molded bearing.

‡ Special 1" bore bearing with extended inner-race.

Many idlers are, or can be, made into a driven pulley with a 5/8" or 3/4" bore.

Please contact Fenner Drives for minimum order quantities, pricing, and availability.

T-Max Belt & Chain Tensioners can be found on pages 39-40.

PowerMax™ Round Belt Idlers

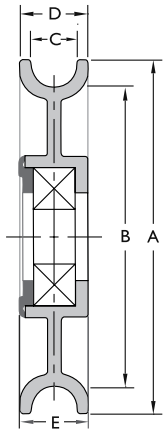

Round Belt Idler

| Part Number | Dimensions (inches) | | | | | Radius | Maximum Belt Size | Bearing Type | Bore Sizes |
|--------------|---------------------|------|------|------|------|--------|-------------------|--------------|------------|
| | A | B | C | D | E | | | | |
| RA3001 | 3.05 | 2.45 | 0.4 | 0.61 | 0.81 | 0.19 | 3/8" | 6203-2RS | 17mm |
| RA3002 | 3.05 | 2.45 | 0.42 | 0.61 | 0.63 | 0.21 | 13/32" | 6203-2RS | 17mm |
| RA3501 | 3.5 | 2.75 | 0.53 | 0.76 | 0.76 | 0.26 | 1/2" | 6203-2RS | 17mm |
| RA3502 | 3.5 | 2.75 | 0.44 | 0.76 | 0.76 | 0.19 | 3/8" | 6203-2RS | 17mm |
| RA4101 | 4.12 | 3.5 | 0.53 | 0.68 | 0.72 | 0.26 | 1/2" | 6203-2RS | 17mm |
| RA4801 | 4.8 | 4 | 0.53 | 1 | 0.77 | 0.28 | 1/2" | 6203-2RS | 17mm |
| RA4802 | 4.82 | 4 | 0.73 | 1.06 | 0.77 | 0.36 | 11/16" | 6203-2RS | 17mm |
| RA5502† | 5.38 | 4.62 | 0.38 | 0.56 | 0.7 | 0.19 | 3/8" | 6203-2RS | 17mm |
| SMALL SERIES | | | | | | | | | |
| RA1850† | 1.84 | 1.39 | 0.4 | 0.63 | 0.63 | 0.16 | 5/16" | 6902-2RS | 15mm |
| RA2540 | 2.54 | 1.9 | 0.44 | 0.63 | 0.63 | 0.16 | 5/16" | 6902-2RS | 15mm |

PowerMax Cable Pulleys

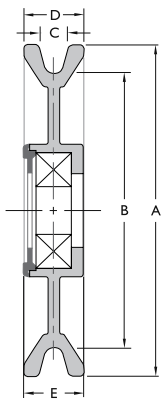

Cable Pulley

| Part Number | Dimensions (inches) | | | | | Maximum Cable Size | Bore Size |
|-------------|---------------------|------|------|------|------|--------------------|-----------|
| | A | B | C | D | E | | |
| RA2701 | 2.75 | 2.43 | 0.23 | 0.54 | 0.82 | 5/32" | 17mm |
| RA3503† | 3.55 | 2.73 | 0.39 | 0.8 | 0.77 | 1/4" | 17mm |
| RA3504 | 3.5 | 2.81 | 0.31 | 0.65 | 0.77 | 7/32" | 17mm |
| RA4501† | 4.46 | 3.74 | 0.38 | 0.86 | 0.77 | 1/4" | 17mm |
| RA4502† | 4.46 | 3.74 | 0.38 | 0.86 | 0.77 | 3/16" | 17mm |
| RA5001 | 5 | 4.31 | 0.31 | 0.65 | 0.73 | 3/16" | 17mm |
| RA5501† | 5.5 | 4.86 | 0.22 | 0.53 | 0.6 | 5/32" | 17mm |
| RA6001 | 6 | 5.2 | 0.4 | 0.8 | 0.8 | 1/4" | 17mm |

PowerMax Sprockets

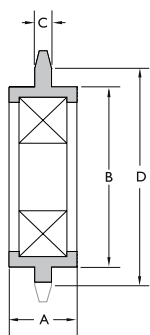

Sprocket

| Part Number | Chain # | # Teeth | Nominal O.D. (in) | Pitch Diameter (in) | Dimensions (inches) | | | Bearing Type | Bore Size |
|-------------|---------|---------|-------------------|---------------------|---------------------|------|-------|--------------|-----------|
| | | | | | A | B | C | | |
| CS3502† | 35 | 19 | 2.48 | 2.28 | 0.67 | 1.78 | 0.164 | 6203-2RS | 17mm |
| CS4002† | 40 | 17 | 2.98 | 2.72 | 0.67 | 1.78 | 0.279 | 6203-2RS | 17mm |
| CS4003† | 40 | 17 | 2.98 | 2.72 | 0.67 | 1.78 | 0.279 | 6203-2RS-10 | 5/8" |
| CS4006*† | 40 | 17 | 2.98 | 2.72 | 0.67 | 1.78 | 0.279 | 6203-2RS-12 | 3/4" |
| CS5002† | 50 | 15 | 3.34 | 3.01 | 0.67 | 1.78 | 0.343 | 6203-2RS | 17mm |
| CS5004† | 50 | 15 | 3.34 | 3.01 | 0.67 | 1.78 | 0.343 | 6203-2RS-10 | 5/8" |
| CS5005*† | 50 | 15 | 3.34 | 3.01 | 0.67 | 1.78 | 0.343 | 6203-2RS-12 | 3/4" |
| CS6002† | 60 | 13 | 3.52 | 3.14 | 0.67 | 1.78 | 0.449 | 6203-2RS | 17mm |
| CS6003† | 60 | 13 | 3.52 | 3.14 | 0.67 | 1.78 | 0.449 | 6203-2RS-10 | 5/8" |
| CS6004† | 60 | 13 | 3.52 | 3.14 | 0.67 | 1.78 | 0.449 | 6203-2RS-12 | 3/4" |
| CS8002† | 80 | 12 | 4.39 | 3.86 | 0.67 | 1.78 | 0.58 | 6203-2RS | 17mm |
| CS8003† | 80 | 12 | 4.39 | 3.86 | 0.67 | 1.78 | 0.58 | 6203-2RS-10 | 5/8" |
| CS8004† | 80 | 12 | 4.39 | 3.86 | 0.67 | 1.78 | 0.58 | 6203-2RS-12 | 3/4" |

* Minimums may apply.

† Insertion molded bearing.

Many idlers are, or can be, made into a driven pulley with a 5/8" or 3/4" bore. Please contact Fenner Drives for minimum order quantities, pricing, and availability. TMax Belt & Chain Tensioners can be found on pages 39-40.

PowerMax™ Carriage Rollers

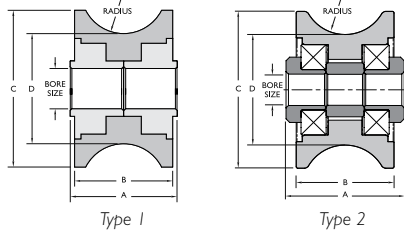

| Part Number | Type | Dimensions (inches) | | | | Radius | Bore Sizes |
|-------------|------|---------------------|-----|------|------|--------|------------|
| | | A | B | C | D | | |
| RA2002 | 1 | 1.36 | 1.2 | 1.95 | 1.37 | 0.53" | 1/2" |
| RA2004 | 1 | 1.48 | 1.2 | 1.95 | 1.37 | 0.53" | 1/2" |
| RX0219 | 2 | 1.48 | 1.2 | 1.95 | 1.38 | 0.53" | 3/8" |

PowerMax Mounting Adapters

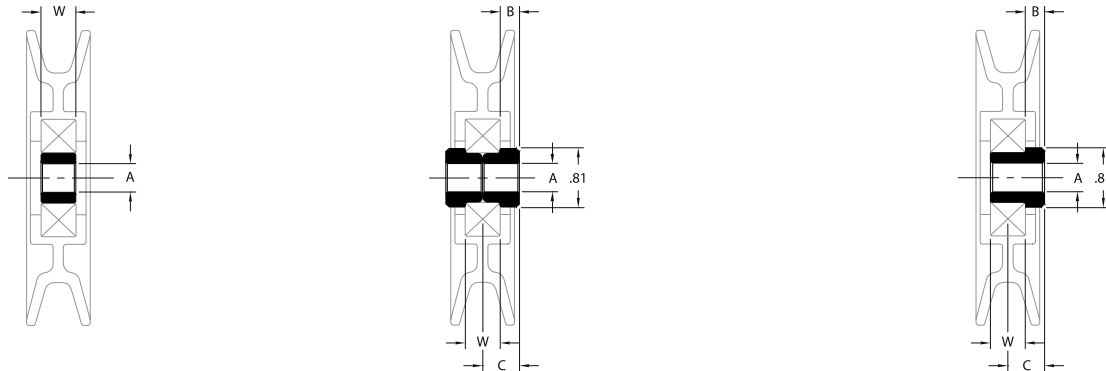

Bore Reducing Adapters

| Part Number | Dimensions (inches) | |
|-------------|---------------------|-------|
| | A | W |
| RB0001 | .385 / .395 | 0.472 |
| RB0002 | .510 / .520 | 0.472 |
| RB0071 | .474 / .486 | 0.472 |

Clevis Adapters

| Part Number | Dimensions (inches) | | | |
|-------------|---------------------|------|-------|------|
| | A | B | W | C |
| CB0001 | .385 / .395 | 0.26 | 0.472 | 0.5 |
| CB0002 | .385 / .395 | 0.51 | 0.472 | 0.75 |
| CB0003 | .385 / .395 | 0.76 | 0.472 | 1 |
| CB0004 | .510 / .520 | 0.26 | 0.472 | 0.5 |
| CB0005 | .510 / .520 | 0.51 | 0.472 | 0.75 |
| CB0006 | .510 / .520 | 0.76 | 0.472 | 1 |
| CB0015 | .314 / .324 | 0.08 | 0.472 | 0.32 |
| CB0016 | .385 / .395 | 0.17 | 0.472 | 0.41 |
| CB0020* | .314 / .324 | 0.1 | 0.472 | 0.34 |
| CB0023 | .394 / .399 | 0.64 | 0.472 | 0.87 |
| CB0036 | .385 / .395 | 0.7 | 0.472 | 0.94 |
| CB0058 | .385 / .395 | 0.33 | 0.472 | 0.57 |
| CB0100 | .397 / .407 | 0.26 | 0.472 | 0.5 |

Shoulder Adapters

| Part Number | Dimensions (inches) | | | |
|-------------|---------------------|------|-------|------|
| | A | B | W | C |
| SB0001 | .385 / .395 | 0.26 | 0.472 | 0.5 |
| SB0002 | .385 / .395 | 0.51 | 0.472 | 0.75 |
| SB0003 | .385 / .395 | 0.76 | 0.472 | 1 |
| SB0004 | .510 / .520 | 0.26 | 0.472 | 0.5 |
| SB0005 | .510 / .520 | 0.51 | 0.472 | 0.75 |
| SB0006 | .510 / .520 | 0.76 | 0.472 | 1 |
| SB0013 | .385 / .395 | 0.15 | 0.472 | 0.38 |
| SB0018 | .385 / .395 | 0.4 | 0.472 | 0.64 |
| SB0020 | .385 / .395 | 0.59 | 0.472 | 0.83 |
| SB0032 | .385 / .395 | 0.56 | 0.472 | 0.8 |
| SB0033 | .385 / .395 | 0.95 | 0.472 | 1.19 |
| SB0052 | .385 / .395 | 0.71 | 0.472 | 0.95 |
| SB0090 | .255 / .265 | 0.31 | 0.472 | 0.55 |

PowerMax DriveN Pulleys

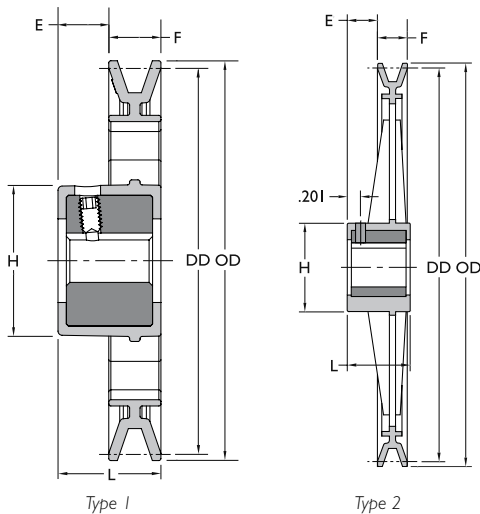

| Base Part Number | Type | Dimensions (inches) | | | | Belt Size | Diameter (inches) | | Number Spokes | Spoke Style |
|------------------|------|---------------------|------|------|------|-----------|-------------------|-------|---------------|-------------|
| | | E | F | H | L | | Outside | Datum | | |
| AFD44* | 1 | 0.79 | 0.74 | 2.17 | 1.53 | A/4L | 4.25 | 4 | - | - |
| AFD49 | 1 | 0.79 | 0.74 | 2.17 | 1.53 | A/4L | 4.75 | 4.5 | 4 | I-Beam |
| AFD59 | 1 | 0.79 | 0.74 | 2.17 | 1.53 | A/4L | 5.75 | 5.5 | 4 | I-Beam |
| AFD74 | 1 | 0.79 | 0.74 | 2.17 | 1.53 | A/4L | 7.25 | 7 | 4 | I-Beam |
| AFD84 | 2 | 0.76 | 0.75 | 2.22 | 1.6 | A/4L | 8.25 | 8 | 6 | Cross |
| AFD94 | 2 | 0.76 | 0.75 | 2.22 | 1.6 | A/4L | 9.25 | 9 | 6 | Cross |
| AFD104 | 2 | 0.76 | 0.75 | 2.22 | 1.6 | A/4L | 10.25 | 10 | 6 | Cross |
| AFD112 | 2 | 0.76 | 0.75 | 2.22 | 1.6 | A/4L | 10.98 | 10.73 | 6 | Cross |
| AFD124 | 2 | 0.76 | 0.75 | 2.22 | 1.6 | A/4L | 12.25 | 12 | 6 | I-Beam |

| Shaft Size | Keyseat |
|------------|---------------|
| 5/8", 3/4" | 3/16" x 3/32" |
| 1" | 1/4" x 1/8" |

Part Number Ordering Guide

| Base Part Number | + | Shaft Size | = | Complete Part Number |
|------------------|---|------------|---|----------------------|
| AFD44 | + | 5/8" | = | AFD4458 |
| AFD94 | + | 1" | = | AFD94100 |

* Minimums may apply.



Engineering Data

Almost all PowerMax Pulleys use precision 6203-2RS chrome-alloy steel radial ball bearings (exceptions are noted). These bearings meet all ABEC-1 standards. Our bearings utilize two rubber wiping seals to keep the grease in and contaminants out. See chart for standard load ratings.

| Bearing Properties | |
|---------------------|---|
| Type | 6203-2RS |
| Seals | Rubber Wiping |
| Fit | ABEC-1 "C4" Internal Clearance |
| Lubrication | Mobil Polyrex EM or equivalent NLGI No. 2 (30% +/- 5% Fill) |
| Service Temperature | -20° – 350°F (-30° – 180°C) |
| Basic Dynamic Load | 2150 lbs. (9563N) |

| 6203 Radial Load Ratings | | | | | | | | | | | |
|--------------------------|------|------|------|------|------|------|------|------|------|------|------|
| Speed (RPM) | 33 | 100 | 200 | 300 | 500 | 1000 | 1500 | 1800 | 2500 | 3600 | 5000 |
| Load (lbs) | 2141 | 1480 | 1175 | 1026 | 866 | 687 | 601 | 565 | 507 | 449 | 402 |
| Load (N) | 9523 | 6583 | 5226 | 4566 | 3852 | 3058 | 2672 | 2514 | 2254 | 1996 | 1789 |

Load Ratings based on 500 HR minimum L_{10} life.

Bearings are also available in stainless steel, with trash seals and shields.

Bearing Life

How long a bearing will last in an application depends on two variables: first, the bearing's physical properties (material, design, method of manufacture); and second, the conditions of operation (load, speed, temperature, lubrication). Although it is not possible to predict the exact life of a bearing, the designer can calculate the " L_{10} Life" of a bearing. L_{10} is the life, in hours or revolutions, that 90% of a group of bearings will complete or exceed. The equations for calculating L_{10} life are:

- Revolutions: $L_{10} = \left(\frac{C}{P}\right)^3 \times 10^6$
- Hours: $L_{10} = \left(\frac{C}{P}\right)^3 \times \frac{16667}{N}$
- Where:
 L_{10} = Rating Life
 C = Basic Dynamic Capacity
 P = Radial Load in lbs.
 N = Speed in RPM

Material Properties

Fenner Drives uses engineering composites, which ensure the highest level of performance and consistent strength. Our standard material is 33% glass reinforced nylon 6/6. The combination of high strength, temperature resistance and abrasion resistance makes nylon a versatile engineering thermoplastic.

| 33% GLASS-REINFORCED NYLON 6/6, dry as molded | | |
|---|-----------|--------------------------------|
| PROPERTY | ASTM CODE | VALUE |
| Tensile Strength at Break | D638 | 20,000 psi |
| Flexural Modulus | D790 | 1,300,000 psi |
| Heat Deflection Temp @ 264 psi | D648 | 480°F (249°C) |
| Continuous Service Temp. (Min. – Max.) | N/A | 32° to 225°F (0° to 107°C) |
| Izod Impact Strength (notched 1/8") | D256 | 1.3 to 1.8 ft.-lb/in. of notch |

Data listed was generated using molded specimens tested under standard conditions. Many of the mechanical properties can be influenced by processing conditions, environmental factors and the application of stress. Therefore, this data characterizes typical production material, and should not be used either to establish specification limits or alone as the basis for engineering design.

PowerTwist

SUPER T LINK

NU T LINK

Tango

EAGLE

TMax

Trantorque

B-LOC

 **RotoShield**

PowerMax

Trackstar

Count on Fenner Drives. We've got the right product for your application.

With over 100 years of manufacturing, technical and commercial expertise, Fenner Drives is a global leader in value-adding, problem-solving products for conveying and power transmission applications. Recognized widely for our expertise and innovation, we blend reliability, quality and value in our products while providing unsurpassed technical support and service.

Visit us at www.fennerdrives.com



www.fennerdrives.com

US and Canada • 1 800 243 3374

Latin America • 1 717 665 2421

Europe, Asia, Australia and Africa • +44 0 870 757 7007



Information subject to change without prior notification. Visit www.fennerdrives.com/catalogs for the most current information.