

DAIDO[®]
CORPORATION OF AMERICA

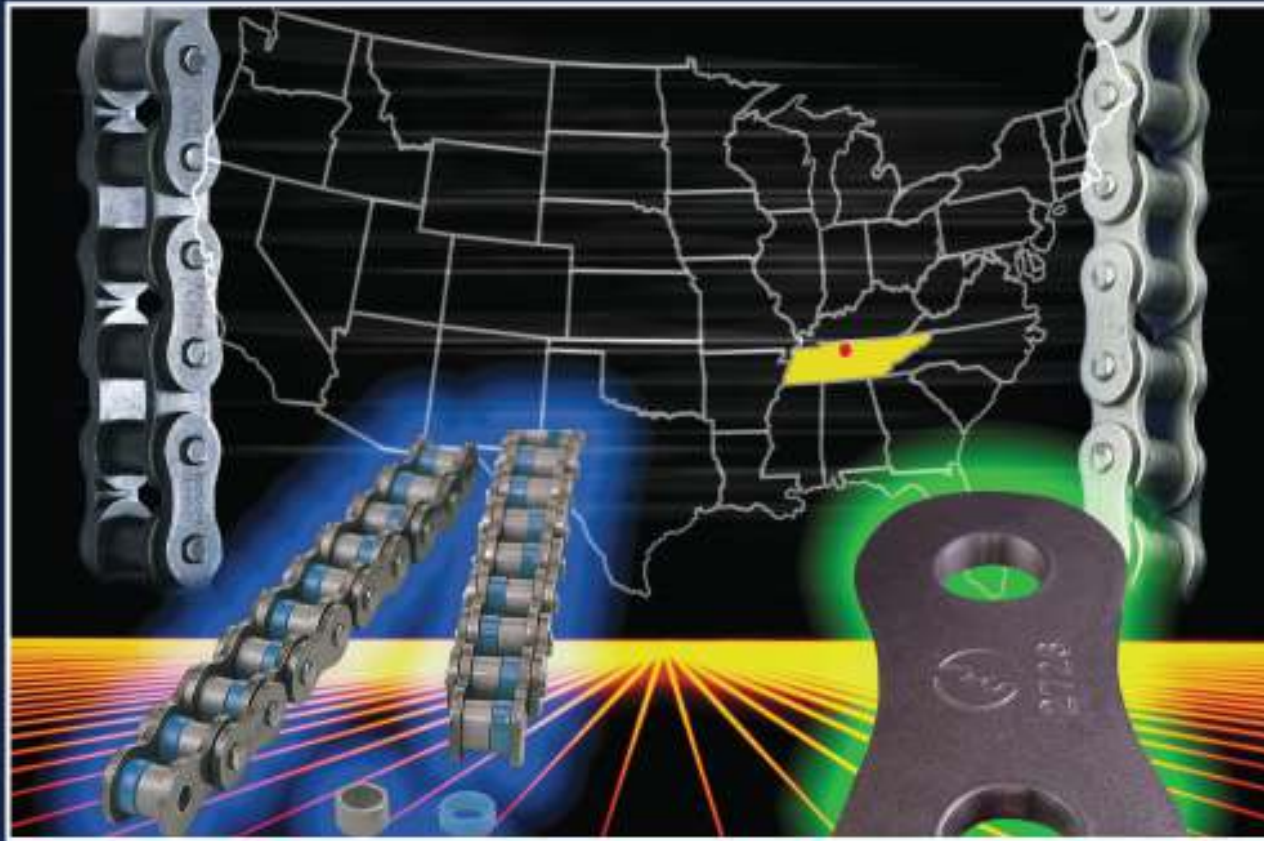

GENERAL CATALOG

POWER TRANSMISSION & CONVEYOR CHAIN



LICENSED
UNDER
7F-0010

Murfeldt
Guides & Tensioners

DID
New Tech Old Chain

ECCO
Engineering Class Chain

PTDA

DID is a brand you can depend on.

Quality Assurance in Conformity with World Standards

Let us introduce our quality assurance system recognized at home and abroad.

Quality assurance of DID

- Customer satisfaction is our priority.
- All Daido members are dedicated and committed to quality.
- Quality control based on facts is assured. With activities based on these quality policies, our quality assurance system is internationally authorized to state that our products conform to ISO9000 series and API.



All of our employees keep Ag Quality Control Practice Manual at hand as the bible of quality and refer to it in routine activities.



Recognition of conformity with ISO9001 series

ISO is the abbreviation of International Standardization Organization, and especially ISO9000 series has been established as "Aga standard of quality assurance from the standpoint of purchasers." Our transmission chains, manufactured at the Fukuda Factory, are ISO9001 certified by the Japanese Quality Assurance Organization (JQA).

Authorization by API

The American oil industry applies rigid quality control standards to all mechanical parts used in oil field development and oil refining. The organization which examines the conformity with their standards for authorization is called API (American Petroleum Institute). Since the authorization by API to use its official monogram in 1972, we have been supplying DID roller chains and sprockets to many companies not only in the USA but also all over the world under the rigid quality control system.

INTRODUCTION

**The D.I.D Brand
Known for its Durability and Dependability in Design. An
established technical innovator in the world chain drive market,
serving a broad spectrum of industries with quality products for
over 60 years. That is D.I.D. Our technology turns timely ideas into
productive realities. D.I.D a professional partnership you can count on for
your optimum drive system solutions.**

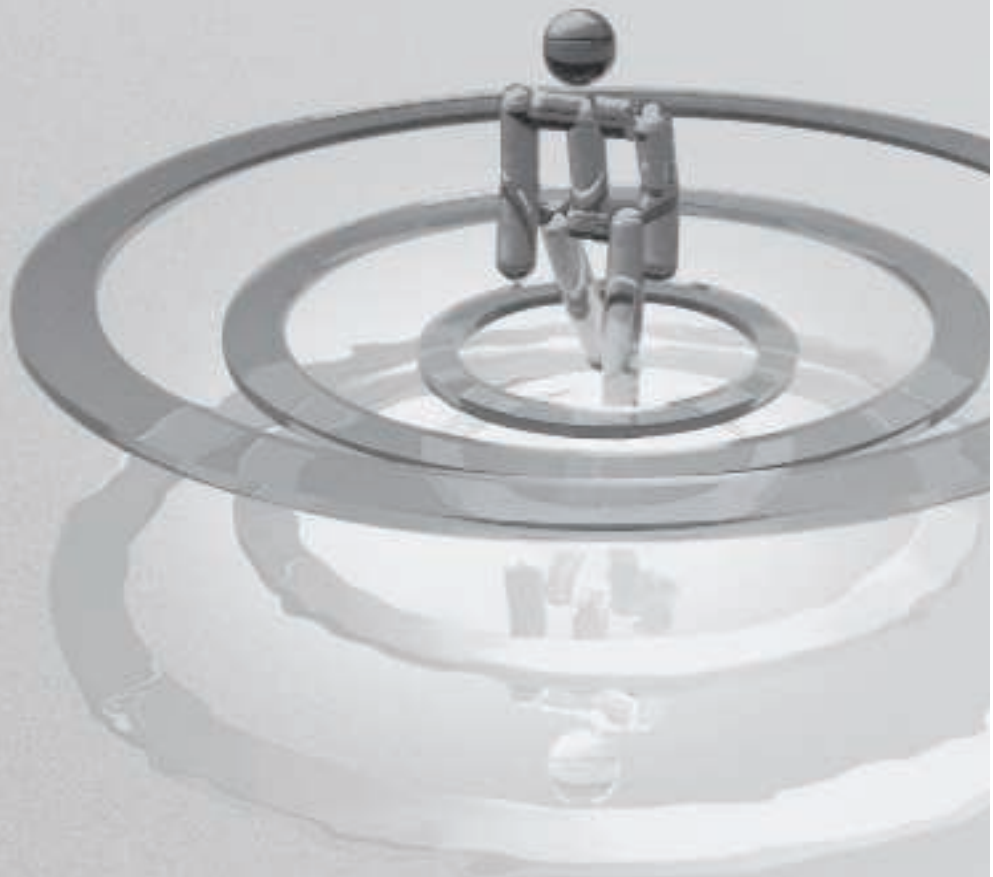

Cautions for handling of chains and sprockets

Before handling chains and sprockets, please understand the respective structures and specifications correctly, and read the following cautions for safely using them.

1. Handling of chains and sprockets

For safe work



- Always wear clothes suitable for work and proper protection (safety glasses, safety shoes, etc.).
- In addition to site workers, other people near the work site are also required to be careful.
- Strictly observe Section 1 “General Standards” (prevention of danger by prime movers, revolution shafts, etc.), Chapter 1, Part 2 of Occupational Safety and Health Regulations.
- For working, keep things in order in and around the work site.
- Before installation, be sure to switch off the power.
Before installing, removing, lubricating or otherwise servicing a chain and sprockets, be sure the main electric power switch and all secondary power switches of the equipment are turned off. Also, take precaution to ensure that power will not be switched on accidentally. Furthermore, exercise care to prevent clothing or any part of the body from being caught by a chain, sprocket or other part during work.
- When any lifting apparatus is used, never stand beneath it.

- For handling, follow the instructions in this catalog and in the instruction manual. Select layout, install, adjust and maintain chain and sprockets in the way that is recommended to ensure a high-performance installation.
- When connecting a chain, employ an installation method suitable for the type of connecting link.
- For the layout, installation, adjustment and maintenance, observe both recommended equipment instructions and cautions.

Warning



- Do not partially replace a chain.
Do not partially exchange a worn or damaged chain and sprockets. Replacing only the worn or damaged part does not restore overall strength, and risks further breaking or destruction. Always replace the entire chain and sprockets.
- Do not modify chains or sprockets.
Most of the components of a chain are heat-treated. If they are modified, strength is diminished and breaking or destruction can result.
- Electroplating assembled chains could cause hydrogen embrittlement.
- Welding should not be performed on any chain or component.
- Annealing can lower the performance of products and components, and may result in destruction.

2. Chain installation

Connection

- (1) Before installation, please read the previous section (1).
- (2) Use connecting links and offset links as described below.
When installing a connecting link or offset link, confirm its construction. (P.11 ~ 13)
 - For installing the spring clip on the connecting link, refer to the method illustrated below.

Chain clip installation method

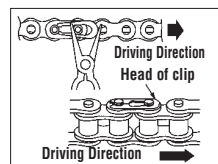

- For installing a cotter pin on the connecting link, refer to the method illustrated below.

Cotter pin installation method

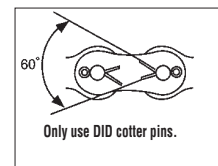
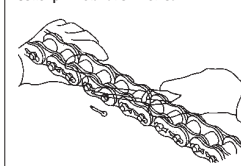

- For installing a spring pin, refer to the method illustrated below. Spring pins are used for interference-fitted connecting links used in K, KS, HK, and HKS series (P.30, P.31~39, P.40~P.42).

Spring pin installation method for HI-PWR-S series

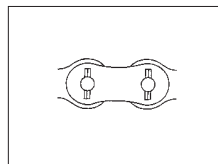
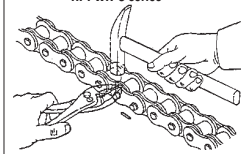

- For installing a T-pin or S-pin, refer to the method illustrated below.

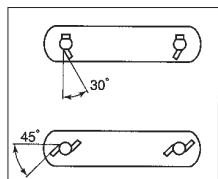
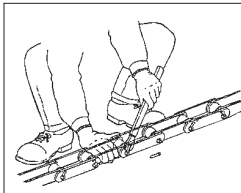

- For installing a one-pitch offset link, refer to the installation method for the cotter type connecting link, and for installing a two-pitch offset link, refer to the installation method of the connecting link used.
For other special types of connecting links, please consult us.

Warning



- Do not attempt to modify any component.
- When assembling, for example, never drill a hole on a connecting plate to make it larger and never file a pin to make it thinner because it will inhibit inserting the pin into the connecting plate.
Do not rework damaged chains.
- Do not re-use a clip and do not install a used cotter or connecting link or any other disassembled component of a chain.

Adjustment

(3) For rated operation of a chain, install and adjust it correctly.

Confirmation

(4) After installing a chain and sprockets, confirm the following before switching on the power:

- Is the connecting link correctly and securely connected?
 - Is the chain engaged with the teeth of the sprockets?
 - Is the amount of lubrication correct?
 - Is anything likely to cause interference or be scattered?
 - Is the safety cover correctly installed?
 - Is there anything interfering with the safety cover?
 - Whether or not there is anything interfering with the chain.
 - If there is anything abnormal about the connecting link portion, etc. and whether the respective components of the chain are flawed, rusty or abnormal in any other way.
 - Do not stand in the rotation direction of the chain.
- (5) If any abnormal sound is generated after switching on the power, switch off the power and re-confirm.

Avoidance of danger



- Install a safety cover.
For the apparatus with a chain and sprockets installed, be sure to install a safety cover. Any unexpected fracture may cause the chain to be thrown from the sprockets. In addition to a sufficient protector, install a stopping device such as an overload limit switch or brake so as not to cause an overload.
- Check for chain interference.
Any obstacle which interferes with a driven chain and sprockets is dangerous and shortens the life of the chain and sprockets. Always check for any interfering objects and remove them.

3. Maintenance

To prevent any serious accident caused by a chain and sprockets, and to prolong the life of the chain and sprockets, take the following maintenance precautions:

Lubrication

(1) Lubrication(See P. 75 & 76.)

Except for some chains made of special materials or elements, most chain life can be prolonged with lubrication. Without lubrication, chain life can be shortened, significantly. (For example: chain elongation, corrosion and stiff joint due to wear of some chain parts.)

Washing

(2)Washing

If a chain is used with a material such as sand or metallic powder, the promotion of wear, stiff joint, etc, will be caused, shortening life. Wash away such harmful materials.

For washing, dip the chain into kerosene, dry, and sufficiently lubricate. However, in the case of O-ring chain, since the O - ring may be deteriorated by kerosene, do not dip it for more than 10 minutes.

For washing, do not use an acid, alkali, gasoline or highly volatile solvent detrimental to the chain and sprockets. For an O- ring chain, do not use a wire brush.

Adjustment

(3)Chain and sprockets are consumable products.

The wear of the chain and sprockets causes the chain to sag. Periodically check the sag, and adjust to achieve the optimum tension. If a chain and sprockets show any rust or harmful flaw in appearance, or if the elongation of a chain or the wear of a sprocket becomes critical, replace them immediately.



- Do not use an offset link for lifting.
- Excessive use of oil will cause scattering, etc. Wipe off extra oil so as to prevent it from scattering.
- For washing, do not use gasoline or highly volatile solvent. Furthermore, do not allow any material containing an acid or alkali to come into contact with it.

4. Others

Even chains of the same kind and size have a different service life, depending on the service environment, number of teeth on the sprockets, lubrication and other conditions. This also applies to the life of sprockets. Chain and sprockets are different in wear life. If a new chain is used on an old sprocket with worn teeth, a non-conforming condition or rupture of the chain may occur.

When a chain or sprocket must be replaced, replace both the chain and sprockets.

If anything remains unclear, please consult us.

Cautions for using roller chain for lifting

Based on the “Chain Safety (Technical) Standard” and “End Fittings” proposed by Japanese Association of Chain Manufacturers to Japanese Sky Parking Areas Association and Japanese Association of Sky Parking Machine Manufacturers in February and October, 1993, the cautions necessary for using roller chain (hereinafter called chain) for lifting are stated below.

CAUTION

1. Safety factor

The “Mechanical Parking Area Technical Standard” sets the safety factors of ropes and chains as “5 for system A”, “7 for system B” and “10 for system C”.

However, if a chain is used at a safety factor of 5 in system A, the acting tension of the chain generally exceeds the maximum allowable tension of the chain. That is, repeated use causes the chain to rupture due to fatigue. Therefore, when a safety factor of 5 for system A is adopted, periodically exchange the chain under strict life control.

2. Selection of chain

2-1 Maximum tension

The maximum tension allowed to act on a chain is set at not higher than the value obtained by dividing the minimum tensile strength of the chain by a safety factor. However, be sure to examine the setting methods recommended by us, and adopt a safe method.

The maximum tension corresponds to the “corrected chain tension” and refers to a tension with especially dynamic load due to start, stop, etc. considered in addition to the offset load by a motor vehicle (difference in weight between front and rear wheels, horizontal shift of the motor vehicle in reference to a pallet, offset load due to the chain lifting position, etc.)

2-2 Connecting link of chain

Standard connecting links have pins clearance-fitted in the connecting plate holes.

The connecting link is lower in fatigue strength than the base chain. When higher fatigue strength is necessary, use connecting links with the pins interference-fitted in the connecting plate holes.

In this case do not use any offset link. As for the types of connecting links, see P.10~P.12.

3. Connection between a chain and an end fitting

The connection between a chain and an end fitting (hereinafter called a fitting) is the section likely to cause problems. For safety purposes, take the following matters into account when you design.

3-1 General cautions

- (1) If the dimensional difference between the inner width of an outer link of a chain and the width of a fitting, the dimensional difference between the pin diameter and the fitting hole are too large, a large bending stress acts to dramatically lower the pin strength.

Refer to “3-3 Dimensions of fitting” in your design.

- (2) If the fitting hole suffers “wear” or “roll over” at its ends during use, the strength of the pin greatly declines as in the case of (1). Periodically check, and if “wear” or “roll over” is found in the fitting hole, exchange the fitting.
- (3) Rust or corrosion is a major reason for decreased strength. During use, take rust preventive actions such as periodically applying grease.
- (4) If a partial load, lateral load or torsional load acts on a chain, the strength of the chain declines. To prevent it, exercise sufficient care in the horizontal fitting of the hole, installation accuracy of fitting, etc.

3-2 Material of fitting and heat treatment

- (1) Hardened fitting

The fitting is generally hardened and tempered. Thoroughly examine the size and material hardness of the fitting, and select a material which ensures a sufficient hardness.

a. In general, a material which ensures the required hardness is selected from tough hardening steels (SCM435, SCM440, etc.) and medium carbon steel.

b. Harden the fitting, and temper at a high temperature, avoiding the temper brittleness range, to a hardness of about HRC30 to 45.

c. In the case of a threaded fitting, keep the hardness at not higher than HRC40, to lower the susceptibility of the threaded portion to delayed fracture.

Select the size of the threaded portion to achieve a tensile strength not lower than the tensile strength of the chain.

(2) Non-hardened fitting

If the fitting is used without being hardened and tempered, the following must be considered.

- a. Since the fitting hole is likely to suffer “wear” or “roll over” during use, press a hard bushing into the fitting hole.
- b. Since the strength of the fitting is lower than that of a hardened and tempered fitting, adequate strength must be secured by adopting corresponding dimensions.

3-3 Dimensions of fitting

Dimensions of general hardened fittings for standard roller chain are listed below. For the fittings of more than triple strands chain and fittings of other shapes, please consult us. When designing an end fitting for any chain other than standard roller chain, work out a safe design based on sufficient understanding of this section. If there is anything unclear, please consult us.

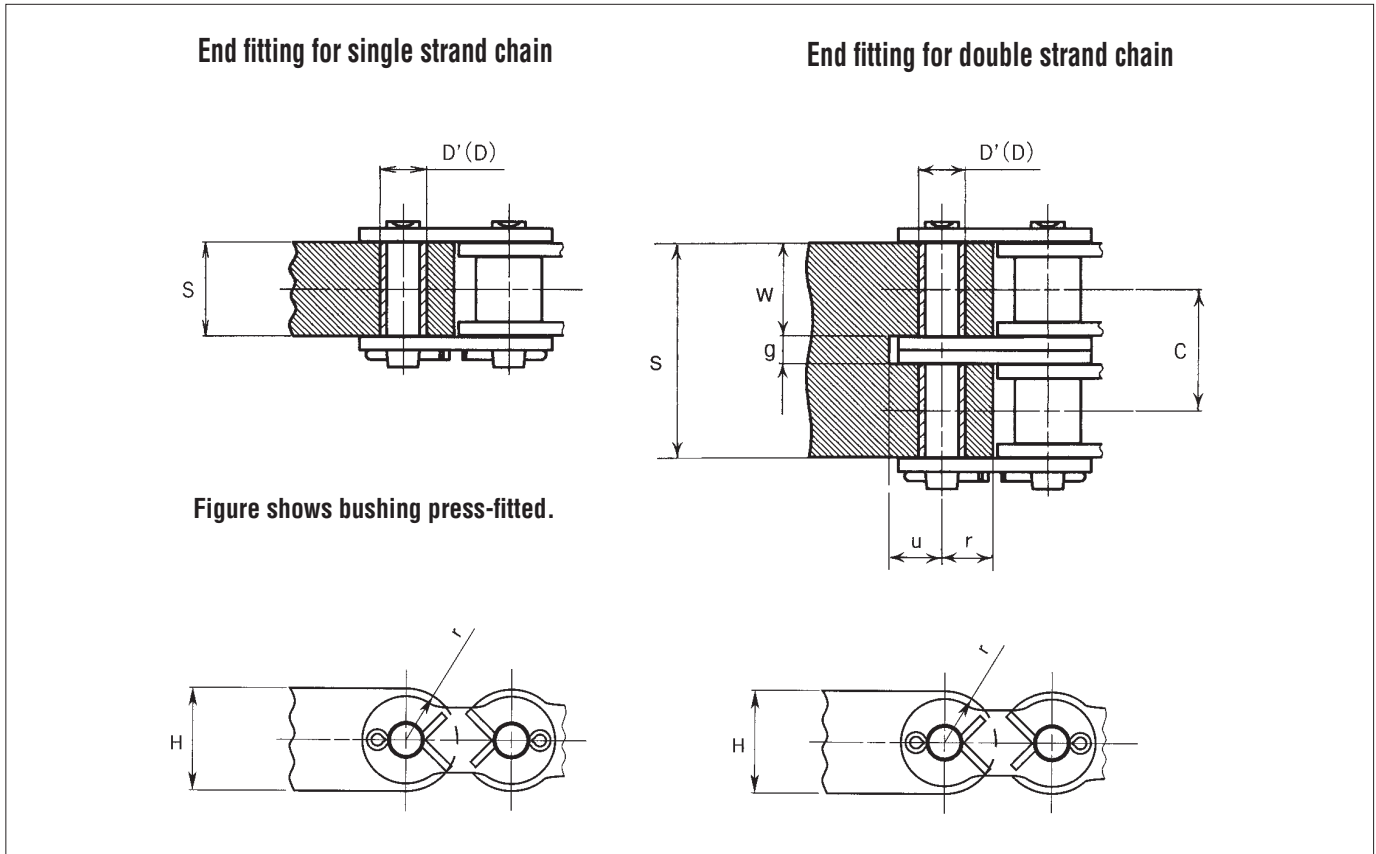

Dimensions of End fitting

Unit (inch)

Chain No.	g	S	D (Without Bushing)	D' (With Bushing)	C	r (Reference)	u (Reference)	H (Reference)
RC60-1	—	0.701	0.236	0.331	—	0.362	—	0.713
RC60-2	0.205	1.591	—	—	0.898	0.362	0.374	—
RC80-1	—	0.890	0.314	0.444	—	0.480	—	0.953
RC80-2	0.268	2.039	—	—	1.154	0.480	0.500	—
RC100-1	—	1.083	0.377	0.530	—	0.598	—	1.189
RC100-2	0.335	2.484	—	—	1.409	0.598	0.622	—
RC120-1	—	1.398	0.439	0.616	—	0.717	—	1.425
RC120-2	0.398	3.177	—	—	1.787	0.717	0.748	—
RC140-1	—	1.465	0.502	0.706	—	0.835	—	1.665
RC140-2	0.472	3.378	—	—	1.925	0.835	0.874	—
RC160-1	—	1.780	0.564	0.746	—	0.953	—	1.902
RC160-2	0.535	4.071	—	—	2.303	0.953	1.000	—

Note: The dimensions of D' can be applied only when DID bushings are used. If these dimensions are applied to the bushings for chain produced by other manufacturers, the strength may be lowered.

**DID's Quality Assurance System
Approved by ISO 9000 and API**



**Caution: For Your Safety
Operation of DID Products 2p**

I Roller Chain for Transmission

1. Outline of DID Chain for Transmission

1-1	Classification	9p
1-2	Construction and Components of Chain	10p
1-3	How to Order Transmission Roller Chain	11p

2. DID General Application Chain

2-1	Dimensions and Performance of DID General Application Chain	12p
2-1-1	Variation for General Application Chain and Connecting Links, Offset Links	12p
2-1-2	ANSI Standard Roller Chain and Maximum Horsepower Ratings.....	13p
	Heavy Type Roller Chain	28p
	A Type Double Pitch Roller Chain	28p

2-2 **DID** Ultimate Power Chain Series29p

2-2-1	K-Series Roller Chain	29p
2-2-2	KS Series Roller Chain & Maximum Horsepower Ratings .	30p
2-2-3	HK Series Roller Chain	39p
2-2-4	HKS Series Roller Chain.....	41p

2-3 **DID** Ultimate Life Chain Series42p

2-3-1	Selection of Ultimate Life Chain Series.....	43p
2-3-2	V Grease Series.....	44p
2-3-3	DHA Chain	45p
2-3-4	O-Ring/X-Ring Chain (LLDR/LDR).....	47p
2-3-5	Sintered Bushing Roller Chain (UR, URF) and Maximum Horsepower Ratings.....	49p

2-4 **DID** Environment Resistant Chain Series . 52p

2-4-1	Selection of Environment Resistant Chain Series	52p
2-4-2	Rustless Chain (N).....	53p
2-4-3	Hi-Guard (E) / Double Guard (WE) Chain.....	54p
2-4-4	Low Temperature Chain (TK).....	54p
2-4-5	Stainless Steel Chain (SS, SSLT)	55p

2-5 **DID** Low Noise Chain Series56p

2-5-1	DID Super Low Noise Chain (SLN) and Maximum Horsepower Ratings.....	56p
-------	--	-----

3. DID Specialty Chain

• Bicycle Chain	59p
• Small Pitch Chain.....	60p
• Leaf Chain	61p
• British Standard Roller Chain.....	63p

4. Design of Roller Chain Transmission

4-1	How to Select the Proper Chain	64p
4-2	Chain Length and Sprocket Center Distance	68p
4-3	Layout	69p

5. Installation, Adjustment & Maintenance

5-1	Installation.....	70p
5-2	Maintenance.....	73p
5-3	Lubrication.....	75p
5-4	Troubleshooting.....	77p
5-5	Timing for Replacement.....	80p

II Roller Chain & Double Pitch Chain for Conveyor Applications

1. Outline of DID Small Chain for Conveyor Applications

1-1	Variation of Base Chain.....	82p
1-2	Ultimate Life Chain Series and Environment Resistant Chain Series.....	82p
1-3	How to Order a Small Chain for Conveyor Applications...	83p

2. Double Pitch Chain

- 2-1 Double Pitch Chain and Dimensions 84p
- 2-2 **DID** Ultimate Life Chain and Environment Resistant Chain Series of Double Pitch Chain 86p

3. Standard Attachments

- 3-1 Standard Roller Chain Attachments 88p
- 3-2 Based on Standard Chain 89p
- 3-3 **DID** Based on O-Ring Chain 92p
- 3-4 **DID** Based on Sintered Bushing Roller Chain 94p
- 3-5 **DID** Based on Stainless Steel Chain 96p

4. DID Chain for Free Flow Conveyors

- 4-1 List of Chain for Free Flow Conveyors 98p
- 4-2 Top Roller Chain 99p
 - 4-2-1 Single Pitch Top Roller Chain 99p
 - 4-2-2 Double Pitch Top Roller Chain 101p
 - 4-2-3 Overturn Prevention Type Chain 102p
- 4-3 Side Roller Chain 103p

- 4-3-1 Single Pitch Side Roller Chain 103p
- 4-3-2 Double Pitch Side Roller Chain 103p
- 4-3-3 Meandering Prevention Type Chain 103p
- 4-4 Free Flow Chain with Brake 104p
 - 4-4-1 Top Roller Chain with Brake 104p
 - 4-4-2 Side Roller Chain with Brake 104p

5. Other Chain for Conveyor Systems

- 5-1 Hollow Pin Chain 105p
- 5-2 Flexible Chain 106p
- 5-3 Straight Side Bar Roller Chain 107p

6. Engineering Information

- 6-1 Calculation of Chain Tension 108p
- 6-2 Strength of Loaded Components 111p

Appendix

- DID Products Which Are Not Covered in This Catalog 112p
- Products Index 113p

For Engineering Information See Web Site www.daidocorp.com



Please visit
www.daidocorp.com
For up to date information.

FRACTION/DECIMAL/METRIC CONVERSION CHART

4th	8th	16th	32nd	64th	Inch	MM
				1/64	.016	.397
			1/32		.031	.794
				3/64	.047	1.191
		1/16			.063	1.588
				5/64	.078	1.984
			3/32		.094	
				7/64	.109	2.788
	1/8				.125	3.175
				9/64	.141	8.572
			5/32		.156	8.969
				11/64	.172	4.366
		3/16			.188	4.762
				13/64	.203	5.159
			7/32		.219	5.556
				15/64	.234	5.953
	1/4				.250	6.350
				17/64	.266	6.747
			9/32		.281	7.144
				19/64	.297	7.541
		5/16			.313	7.938
				21/64	.328	8.334
			11/32		.344	8.731
				23/64	.359	9.128
		3/8			.375	9.525
				25/64	.391	9.922
			13/32		.406	10.319
				27/64	.422	10.716
		7/16			.439	11.112
				29/64	.453	11.509
			15/32		.469	11.906
				31/64	.484	12.303
	1/2				.500	12.700

4th	8th	16th	32nd	64th	Inch	MM
				33/64	.516	13.097
			17/32		.531	13.494
				35/64	.547	13.891
		9/16			.563	14.288
				37/64	.578	14.684
			19/32		.594	15.081
				39/64	.609	15.478
	5/8				.625	15.875
				41/64	.641	15.272
			21/32		.656	16.669
				43/64	.672	17.066
			11/16		.688	17.462
				45/64	.703	17.859
			23/32		.719	18.256
				47/64	.734	18.653
	1/4				.750	19.050
				49/64	.766	19.447
			25/32		.781	19.844
				51/64	.797	20.241
		13/16			.812	7.938
				53/64	.828	21.034
			27/32		.844	21.431
				55/64	.859	21.828
		7/8			.875	22.225
				57/64	.891	22.622
			29/32		.906	23.019
				59/64	.922	23.416
		15/16			.938	23.812
				61/64	.953	24.209
			31/32		.969	24.606
				63/64	.984	25.003
	1/2				1.000	25.400

Roller Chain for Transmission



D.I.D NEW TECH CHAIN SERIES



D.I.D ULTIMATE POWER SOLUTION SERIES

Achieves up to 25% higher tensile strength and 50% higher Fatigue Strength than standard roller chain.



D.I.D ULTIMATE LIFE CHAIN SERIES

Achieves up to 25% higher tensile strength and 50% higher Fatigue Strength than standard roller chain.



D.I.D ENVIRONMENT RESISTANT CHAIN SERIES

Stainless steel and unique coatings for any corrosive environment.



D.I.D SUPER LOW NOISE

Incredibly quiet. Reduces noise up to 10db.



MURTFELDT CHAIN GUIDES & TENSIONERS

Utilize chain's maximum potential and minimize the downtime for maintenance.



DAIDO CORPORATION OF AMERICA

Warehouse and Service Department.

1. Outline of DID Power Transmission Chain

1-1 Classification

DID products for transmission can be classified into “General application chain”, “Specialty chain”, “chain-related products” and “sprockets”.

The “General application chain”, with their sprockets in conformity with ANSI, are used in a wide range of areas for various applications. They are provided as “Ultimate life chain series”, “Environment resistant chain series” and “Low noise chain series” to suit respective applications. So, you can select chain for a lubrication rejecting condition, highly corrosive environment, silence demanded environment, etc. The “Specialty chain” include a variety of chain such as “Bicycle chain”, “Small pitch chain” mainly used for office machines and “Engine mechanism chain”,

“Silent chain” known for silent operation, “Motorcycle chain”, and “Agricultural chain”. Furthermore, “Leaf chain” for lifting heavy things and quite different from roller chain in form, “BS type roller chain” of British standard, and in addition, “chain related products” such as “roller chain couplings”, “chain lube” and “chain wear-elongation check gage” are also available. As for “sprockets”, those with a hub on one side only, are kept in stock. Our chain technology has grown in areas of motorcycles and motor vehicles, and abundantly accumulated know how supports the “General application chain” and “Specialty chain” and can rapidly respond to demand for various applications.

Classification

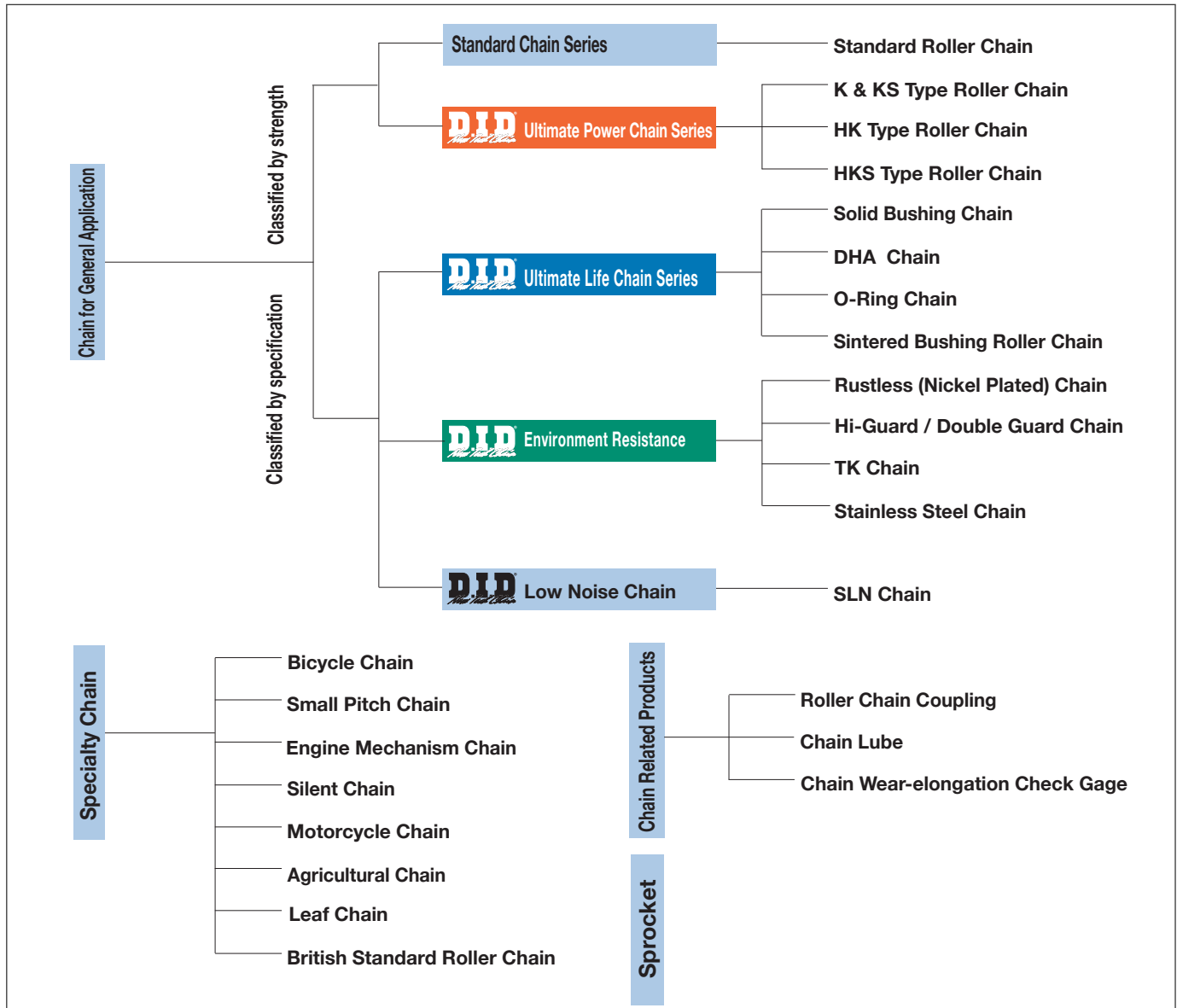

1-2 Construction and Components of Chain

A roller chain has a structure as illustrated below, and the names of the components are stated in the drawing. These components act as described below, and are designed to suit the respective actions.

Components	Pin	Pins support all the load acting on the chain, together with inner and outer plates, and when the chain is engaged with a sprocket, the pins slide as bearings. They are required to be high in shearing strength and bending strength, and especially wear resistance.
	Bushing	Bushings act to prevent the shock received through rollers, when the chain is engaged with a sprocket, from being directly transmitted to pins, and also act as bearings, along with the pins. So, they are required to be high in shock fatigue strength and wear resistance.
	Roller	Rollers act to smoothly bend the chain when the chain is engaged with a sprocket, to protect the chain from shock with the sprocket. They are required to be high in shock fatigue strength, collapse strength and wear resistance.
	Plate	Plates are subject to repeated tension of the chain, and sometimes a large shock. So, they are required to be high in tensile strength, and also in shock resistance and fatigue strength.

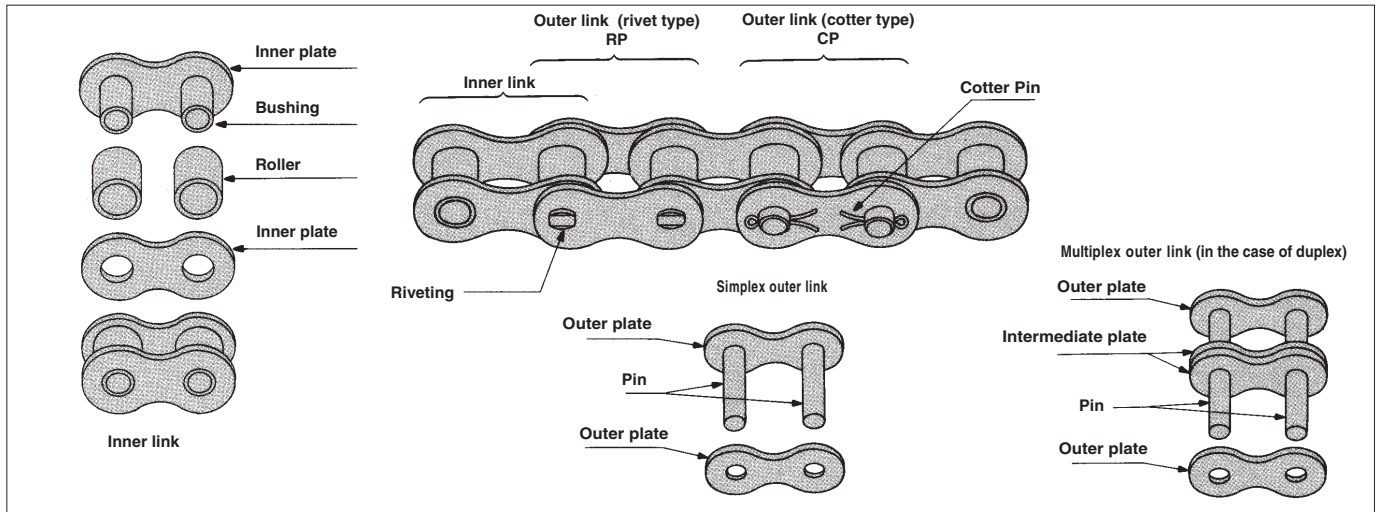

Connecting links

The following four types of connecting links are available.

Offset link

An offset link is used for increasing or decreasing the length of a chain by one pitch, the following two types are available:

Spring Clip type connecting link

Outer plate
Spring clip type connecting pin
Connecting plate
Spring clip

Spring Clip type connecting link is available in clearance fit (slip fit) and interference fit (semi-press fit) types.

Cotter Pin type connecting link

Outer plate
Cotter type connecting pin
Connecting plate
Cotter pin

Cotter Pin type connecting link is available in clearance fit (slip fit) and interference fit (semi-press fit) types.

Roll Pin type connecting link

Outer plate
Spring pin type connecting pin
Connecting plate
Roll (Spring) pin

Roll Pin type connecting link is interference fit (semi-press fit) type connecting link for heavy duty chain series (Ultimate Power Series) roller chain such as KS, HK and HKS type roller chain (P.30)

offset plate
Offset pin
Cotter pin
One-pitch offset link (HL)

offset plate
Two-pitch offset link (2PHL)

Since the “connecting link” and “offset link” are lower than the base chain in strength, any service condition in excess of the maximum Horsepower rating is subject to consulting with us.

*** Clearance fit (slip fit)**

In this fit, when a pin and a hole are combined, it has clearance between them, since the diameter of the hole is slightly larger than the pin diameter. This method is used in standard connecting links.

*** Interference fit (press or semi-press fit)**

In this fit, when a pin and a hole are combined, an interference occurs always, since the diameter of the hole is slightly smaller than the pin diameter. This method is adopted; in chain such as Ultimate Power Series that require greater fatigue strength than standard chain.

1-3 How to Order Transmission Roller Chain

• When you order RC60LLDR X 160 links endless with standard connecting

[Type indication]

RC 60 LLDR X 160 J E

Roller Chain: RC
 Size: 60
 Type of Chain: LLDR
 Chain No.: X 160
 Chain Length: 160
 End Type: J E

Indication of End Type (connecting link)

PS  ... A connecting link is packed separately with the chain.

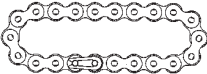
JE  ... Endless with a connecting link already installed.

ATOE  ... A connecting link is attached to one end.

BERL ... No connecting link to be included. Both Ends Roller Link. Please provide descriptions for special arrangement.

Spring clip type — { Clearance fit : R
 Interference fit : F }
 Cotter type — { Clearance fit : C
 Interference fit : H }
 Some are inapplicable, depending on the chain size. See the table on P13.

• When you order RC80C x 121 links including 3 offset link (HL) and 1 cotter type connecting link

RC 80 C X 121 **incl. 3HL and 1CL**

Roller Chain: RC
 Size: 80
 Type of Chain: C
 Chain Length (links): X 121
 Description: incl. 3HL and 1CL

C: Cotter Pin Type
 R: Rivet Pin Type

Please provide descriptions for special arrangement.

• When you order for cotter type slip fit connecting link for RC80

CL 80 Cotter

Connecting Link: CL
 Size: 80
 Type of Connecting Link: Cotter

e.g. Clip / Cotter / PL (pin link or R)

Type of Connecting Link
 No indication: Daido Standard

- Clip type slip fit connecting link for #60 and smaller.
- Cotter type slip fit connecting link for #80 and larger
- Semi press fit type is our standard connecting link for Ultimate Power Series chain (P30 - P42)

• When you order for half link (offset link) for RC60

HL 60

Offset (Half) Link: HL
 Size: 60

- 2 pitch offset link is also available.
- 2 pitch offset link is standard for RC25 (P13) and O-Ring chain (P48).

2. DID General Application Chain

2-1 Dimensions and performance of DID general application chain

DID general application chain can be classified, in reference to strength, into standard series of JIS roller chain and HK series in conformity with ANSI. The inner and outer plates of an HK chain are equal in thickness, to those of a standard chain which is larger than the former by one size.

The standard series include two lines; standard roller chain, and K & KS type chain improved in fatigue strength and shock resistance compared to the standard roller chain. You can use them as basic transmission chain for all applications ranging from low speed to high speed.

The HK series are improved in the strength of plates to allow heavy duty transmission mainly in a low speed range, and include two lines; HK type roller chain and HKS type roller chain further enhanced in fatigue strength.

Sprockets

The chain can be engaged with standard sprockets of the corresponding nominal numbers.

Number of chain strands and method for connecting outer plates with pins

The numbers of strands which can be manufactured are as listed below.

The standard method for connecting pins and plates is rivet type.

Standard chain and HK type chains of RC80 or larger can also be manufactured as cotter type.

KS type chains and HKS type chains have manufactured as rivet type only.

Connecting links and Offset links

For connecting links and offset links, see the following table showing kinds of general application, chain, connecting links and offset links.

This section describes general application chain only. However since many kinds of engine mechanism chain and agricultural roller chain are also available. Please see the sections describing the respective items.

2-1-1 Variation for General Application Chain and Connecting Links, Offset Links

Classification (Max. allowable load ratio)	ANSI Standard Roller Chain (100%)			KS Series Roller Chain (approx. 130%)			HK Series Roller Chain (ap- prox. 110%)			HKS Series Roller Chain (ap- prox. 150%)		
	Chain Size	Connecting link	Offset link	Chain Size	Connecting link	Offset link	Chain Size	Connecting link	Offset link	Chain Size	Connecting link	Offset link
Standard Connecting Links	RC25	Slip Fit/Clip	2p-Offset Link				RC25H	Slip Fit/Clip	2p-Offset Link			
	RC35	Slip Fit/Clip	2p-Offset Link				RC35HK	Slip Fit/Clip				
	RC41	Slip Fit/Clip	Offset Link									
	RC40	Slip Fit/Clip	Offset Link				RC40HK	Slip Fit/Clip				
	RC50	Slip Fit/Clip	Offset Link				RC50HK	Semi Press/Clip	Offset Link			
	RC60	Slip Fit/Clip	Offset Link				RC60HK	Semi Press/Clip	Offset Link			
	RC80	Slip Fit/Cotter	Offset Link	RC80KS	Simi Press/Roll Pin		RC80HK	Semi Press/Roll Pin	Offset Link	RC80HKS	Semi Press/Roll Pin	NA
	RC100	Slip Fit/Cotter	Offset Link	RC100KS	Simi Press/Roll Pin		RC100HK	Semi Press/Roll Pin	Offset Link	RC100HKS	Semi Press/Roll Pin	NA
	RC120	Slip Fit/Cotter	Offset Link	RC120KS	Simi Press/Roll Pin		RC120HK	Semi Press/Roll Pin	Offset Link	RC120HKS	Semi Press/Roll Pin	NA
	RC140	Slip Fit/Cotter	Offset Link	RC140KS	Simi Press/Roll Pin		RC140HK	Semi Press/Roll Pin	Offset Link	RC140HKS	Semi Press/Roll Pin	NA
	RC160	Slip Fit/Cotter	Offset Link	RC160KS	Simi Press/Roll Pin		RC160HK	Semi Press/Roll Pin	Offset Link	RC160HKS	Semi Press/Roll Pin	NA
	RC180	Slip Fit/Cotter	Offset Link	RC180KS	Simi Press/Roll Pin		RC180HK	Semi Press/Roll Pin	Offset Link	RC180HKS	Semi Press/Roll Pin	NA
	RC200	Slip Fit/Cotter	Offset Link	RC200KS	Simi Press/Roll Pin		RC200HK	Semi Press/Roll Pin	Offset Link	RC200HKS	Semi Press/Roll Pin	NA
	RC240	Slip Fit/Cotter	Offset Link	RC240KS	Simi Press/Roll Pin		RC240HK	Semi Press/Roll Pin	Offset Link	RC240HKS	Semi Press/Roll Pin	NA
Max. Strands Available	5 (single strand only for RC41)			3			Single Strand only for RC60HK and under / 3 for RC80HK and over			3		

2-1-2 Standard Roller Chain and Maximum Horsepower Ratings

The DID standard roller chains are available in 14 sizes ranging from RC25 to RC240. All are in conformity with JIS (Japanese Industrial Standards) and ANSI (American National Standard Institute) standards.



Cautions for use

1. For chain selection, see “Tables of maximum horsepower ratings for standard roller chains” (P.14~ 27) and “Designing of roller chain transmission”.
2. Standard roller chains up to quintuplex can be manufactured. For their dimensions, see the pages referring to the maximum horsepower ratings.
3. The connecting links are generally Clip Type or Cotter Type connecting links in which the pins are clearance-fitted with the connecting plate. Since clearance-fit links are inferior to the base chain in maximum allowable load as in the case of one pitch offset

- links. Since the maximum horsepower ratings are determined considering the strength of connecting links and offset links, the clearance-fit connecting links and offset links can be used if they are selected according to the “General selection”.
4. For severe applications, use interference-fit connecting links and/or Ultimate Power Series roller chain. For the use of offset links, 2P offset link is recommended

TRANSMISSION
ROLLER CHAIN

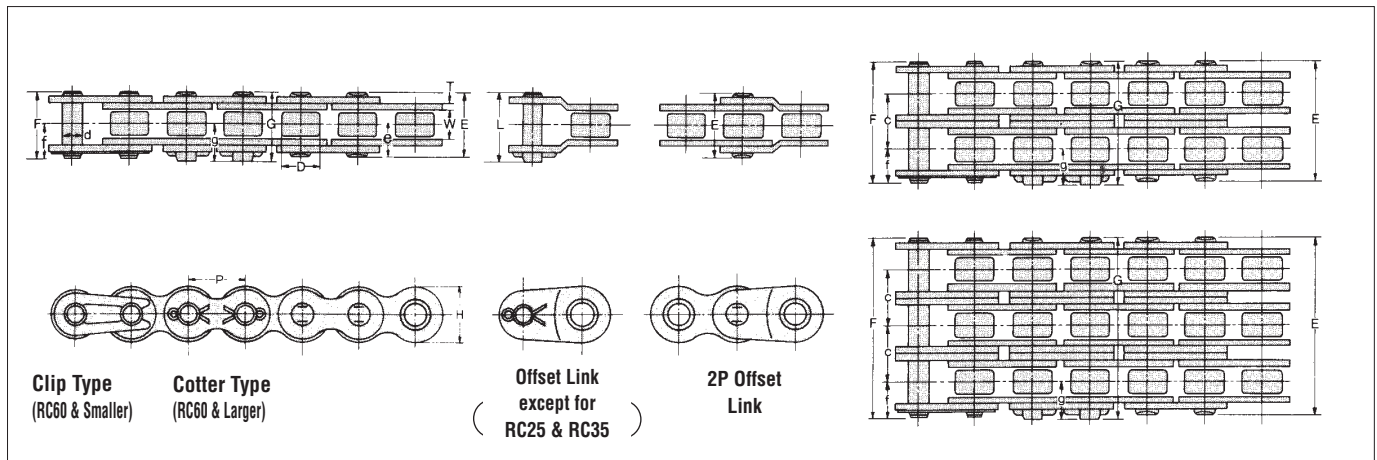

Dimensions

Unit (inch)

Chain No.		Pitch P	Roller Link Width W	Roller (Bush) Dia. D	Pin							Transverse Pitch C	Plate		JIS Min. Tensile Strength lbs	DID Min. Tensile Strength lbs	DID Avg. Tensile Strength lbs	DID Max. Allowable Load lbs	Approx. Weight (lbs/ft)	No. of Links per Unit
DID	ANSI				d	E	F	G	L	f	g		T	H						
*RC25	25	0.250	0.125	0.130	0.091	0.307	0.335	---	---	0.185	---	0.252	0.028	0.232	785	814	990	165	0.09	480
*RC35	35	0.375	0.188	0.200	0.141	0.472	0.516	---	---	0.287	---	0.398	0.049	0.354	1773	1980	2530	484	0.21	320
RC41	41	0.500	0.251	0.306	0.141	0.539	0.575	---	0.602	0.311	---	---	0.047	0.378	1503	1980	2420	528	0.26	240
RC40	40	0.500	0.313	0.312	0.156	0.650	0.693	---	0.760	0.374	---	0.567	0.059	0.472	3095	3520	4290	836	0.42	240
RC50	50	0.625	0.375	0.400	0.200	0.799	0.862	---	0.909	0.457	---	0.713	0.079	0.591	4891	5940	6930	1540	0.71	192
RC60	60	0.750	0.500	0.469	0.235	1.000	1.059	1.098	1.181	0.563	0.594	0.898	0.094	0.713	6978	7920	9900	2090	0.97	160
RC80	80	1.000	0.625	0.625	0.313	1.283	---	1.394	1.433	---	0.748	1.154	0.126	0.945	12474	16060	17600	3300	1.71	120
RC100	100	1.250	0.750	0.750	0.376	1.555	---	1.673	1.713	---	0.898	1.409	0.157	1.177	19450	24200	26620	5060	2.54	96
RC120	120	1.500	1.000	0.875	0.437	1.957	---	2.087	2.130	---	1.110	1.787	0.189	1.413	27953	33000	37400	6820	3.68	80
RC140	140	1.750	1.000	1.000	0.500	2.110	---	2.299	2.346	---	1.244	1.925	0.220	1.650	37913	43340	48400	9020	4.77	68
RC160	160	2.000	1.250	1.125	0.563	2.504	---	2.685	2.744	---	1.433	2.303	0.252	1.882	49892	55000	60500	11880	6.58	60
RC180	180	2.250	1.406	1.406	0.687	2.815	---	3.043	3.122	---	1.630	2.591	0.280	2.118	---	74800	81400	13860	8.52	54
RC200	200	2.500	1.500	1.562	0.781	3.067	---	3.346	3.437	---	1.807	2.819	0.315	2.362	77845	96800	105600	16500	11.06	48
RC240	240	3.000	1.875	1.875	0.937	3.748	---	4.051	4.150	---	2.189	3.457	0.374	2.815	112259	139700	154000	22220	15.62	40

Note: Those marked with * indicate bush chain.

RC25 Standard Roller Chain

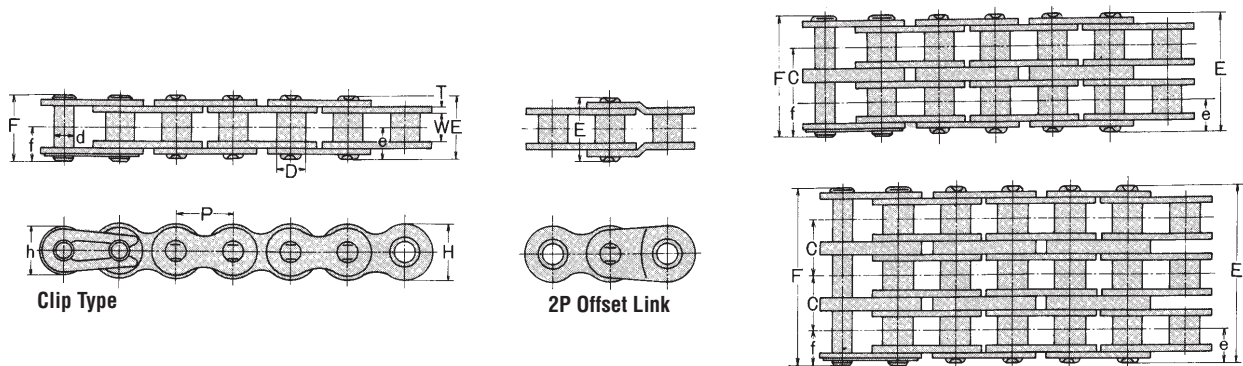

Dimensions

Unit (inch)

Chain No.		Pitch P	Roller Link Width W	Bush Dia. D	Pin					Trans- verse Pitch C	Plate			JIS Min. Tensile Strength lbs	DID Min. Tensile Strength lbs	DID Avg. Tensile Strength lbs	DID Max. Allowable Load lbs	Approx. Weight (lbs/ft)
DID	ANSI				d	E	F	e	L		T	H	h					
RC25	25	0.250	0.125	0.130	0.091	0.307	0.335	0.154	0.185	0.252	0.028	0.232	0.205	785	814	990	165	0.09
RC25-2	25-2					0.567	0.591							1571	1628	1980	264	0.17
RC25-3	25-3					0.819	0.843							2356	2442	2970	396	0.26
RC25-4	25-4					1.071	1.094							3142	3256	3960	528	0.35
RC25-5	25-5					1.327	1.350							3927	4070	4950	638	0.44

Max. Horsepower Ratings

Unit (hp)

Type of Lubrication No. of Teeth of Small Sprocket	Revolutions per minute-Small Sprocket (rpm) (Please refer to P.76 for more details regarding type of lubrication A, B and C.)																			
	100	500	900	1200	1800	2500	3000	3500	4000	4500	5000	5500	6000	6500	7000	7500	8000	8500	9000	10000
	A																			
11	0.05	0.24	0.42	0.54	0.78	1.03	1.22	1.41	1.38	1.15	0.99	0.86	0.75	0.67	0.59	0.54	0.48	0.44	0.40	0.35
12	0.07	0.27	0.46	0.59	0.84	1.14	1.34	1.54	1.57	1.31	1.13	0.98	0.86	0.76	0.68	0.62	0.55	0.51	0.47	0.40
13	0.07	0.29	0.50	0.64	0.92	1.25	1.46	1.68	1.77	1.49	1.27	1.10	0.97	0.86	0.76	0.68	0.63	0.58	0.52	0.44
14	0.08	0.32	0.54	0.70	1.01	1.34	1.58	1.82	1.98	1.66	1.42	1.23	1.07	0.95	0.86	0.78	0.70	0.64	0.59	0.50
15	0.08	0.34	0.58	0.75	1.07	1.45	1.70	1.96	2.20	1.84	1.57	1.37	1.19	1.06	0.95	0.86	0.78	0.71	0.66	0.55
16	0.08	0.36	0.62	0.80	1.15	1.55	1.84	2.10	2.37	2.02	1.73	1.50	1.31	1.17	1.05	0.94	0.86	0.78	0.71	0.62
17	0.09	0.39	0.66	0.86	1.23	1.66	1.96	2.24	2.53	2.23	1.89	1.65	1.45	1.27	1.14	1.03	0.94	0.86	0.79	0.67
18	0.09	0.42	0.70	0.91	1.31	1.77	2.08	2.39	2.69	2.43	2.06	1.80	1.57	1.39	1.25	1.13	1.02	0.94	0.86	0.72
19	0.11	0.44	0.75	0.97	1.39	1.88	2.20	2.53	2.86	2.63	2.24	1.94	1.70	1.51	1.35	1.22	1.11	1.01	0.92	0.79
20	0.11	0.47	0.79	1.02	1.47	1.97	2.33	2.68	3.02	2.83	2.43	2.09	1.84	1.64	1.46	1.31	1.19	1.09	1.01	0.86
21	0.12	0.50	0.83	1.07	1.55	2.08	2.45	2.82	3.18	3.04	2.60	2.25	1.98	1.76	1.57	1.42	1.29	1.18	1.07	0.92
22	0.12	0.51	0.87	1.13	1.64	2.18	2.59	2.96	3.35	3.27	2.79	2.43	2.12	1.88	1.69	1.51	1.38	1.26	1.15	0.99
23	0.12	0.54	0.91	1.19	1.72	2.29	2.71	3.11	3.51	3.50	2.99	2.59	2.27	2.01	1.80	1.62	1.47	1.34	1.23	1.06
24	0.13	0.56	0.97	1.25	1.80	2.41	2.84	3.26	3.67	3.73	3.18	2.76	2.43	2.14	1.92	1.73	1.57	1.43	1.31	1.13
25	0.13	0.59	1.01	1.30	1.88	2.52	2.96	3.40	3.83	3.95	3.38	2.94	2.57	2.28	2.04	1.84	1.68	1.53	1.39	1.19
28	0.16	0.67	1.14	1.47	2.12	2.84	3.35	3.85	4.34	4.69	4.01	3.47	3.04	2.71	2.43	2.18	1.98	1.81	1.66	1.42
30	0.17	0.72	1.22	1.58	2.28	3.06	3.61	4.14	4.68	5.20	4.45	3.85	3.38	3.00	2.68	2.43	2.20	2.01	1.84	1.57
32	0.19	0.78	1.31	1.70	2.44	3.28	3.87	4.45	5.01	5.58	4.89	4.25	3.73	3.30	2.96	2.67	2.43	2.21	2.02	1.73
35	0.20	0.84	1.45	1.86	2.69	3.62	4.26	4.89	5.52	6.14	5.60	4.85	4.26	3.78	3.38	3.04	2.76	2.53	2.32	1.98
40	0.23	0.98	1.66	2.16	3.11	4.18	4.92	5.66	6.38	7.09	6.85	5.94	5.20	4.61	4.13	3.73	3.38	3.08	2.83	2.43
45	0.27	1.11	1.89	2.45	3.53	4.75	5.59	6.42	7.24	8.06	8.16	7.08	6.21	5.51	4.93	4.45	4.03	3.69	3.38	2.88
50	0.29	1.25	2.12	2.75	3.95	5.32	6.26	7.20	8.12	9.02	9.57	8.28	7.28	6.45	5.78	5.20	4.73	4.32	3.95	3.38
55	0.32	1.38	2.35	3.04	4.38	5.90	6.94	7.98	8.99	10.0	11.0	9.57	8.39	7.44	6.66	6.01	5.46	4.97	4.57	3.90
60	0.36	1.51	2.59	3.35	4.81	6.47	7.63	8.77	9.88	11.0	12.1	10.9	9.57	8.49	7.59	6.85	6.21	5.67	5.20	4.45

Note: Value in above table is for single strand chain only.

For multiplex chain, please apply the coefficient of Multi-strand. Please refer to chain selection on P.64.

RC35 Standard Roller Chain

TRANSMISSION
ROLLER CHAIN

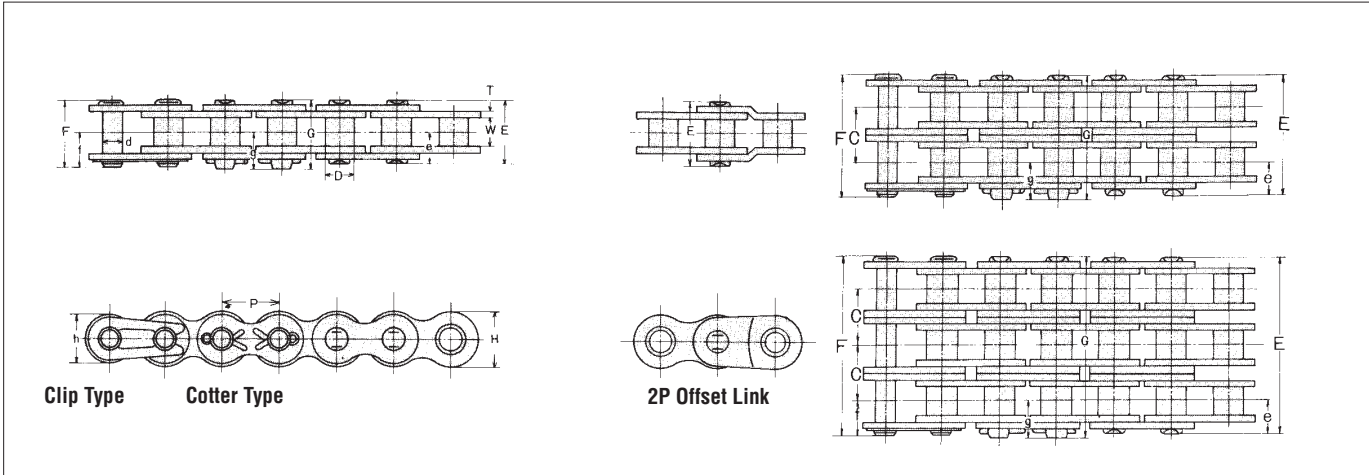

Clip Type Cotter Type

2P Offset Link

Dimensions

Unit (inches)

Chain No.	Pitch	Roller Link Width W	Bush Dia. D	Pin								Transverse Pitch C	Plate			JIS Min. Tensile Strength lbs.	DID Min. Tensile Strength lbs.	DID Avg. Tensile Strength lbs.	DID Max. Allowable Load lbs.	Approx. Weight (lbs/ft)
				d	E	F	G	e	f	g	T		H	h						
RC35	35	0.375	0.188	0.200	0.141	0.472	0.516	0.555	0.236	0.287	0.291	0.398	0.049	0.354	0.305	1773	1980	2530	484	0.21
RC35-2	35-2					0.870	0.913	0.925								3546	3960	5060	814	0.46
RC35-3	35-3					1.268	1.315	1.327								5320	5940	7590	1210	0.70
RC35-4	35-4					1.665	1.713	1.724								7093	7920	10120	1584	0.95
RC35-5	35-5					2.067	2.114	2.126								8866	9900	12650	1870	1.19

Max. Horsepower Ratings

Unit (hp)

Type of Lubrication No. of Teeth of Small Sprocket	Revolutions per minute-Small Sprocket (rpm) (Please refer to P.76 for more details regarding type of lubrication A, B and C.)																			
	100	500	900	1200	1800	2500	3000	3500	4000	4500	5000	5500	6000	6500	7000	7500	8000			
	8500	9000	10000																	
11	0.23	0.99	1.69	2.18	3.14	3.86	2.94	2.33	1.90	1.60	1.37	1.18	1.03	0.92	0.82	0.74	0.67	0.62	0.56	0.48
12	0.25	1.09	1.85	2.40	3.45	4.40	3.35	2.65	2.17	1.82	1.55	1.35	1.18	1.05	0.94	0.84	0.76	0.70	0.64	0.55
13	0.28	1.19	2.01	2.61	3.77	4.96	3.78	2.99	2.45	2.05	1.76	1.51	1.34	1.18	1.06	0.95	0.87	0.79	0.72	0.62
14	0.31	1.29	2.18	2.83	4.08	5.48	4.22	3.35	2.73	2.29	1.96	1.70	1.49	1.33	1.18	1.07	0.97	0.88	0.82	0.70
15	0.32	1.38	2.36	3.04	4.40	5.90	4.68	3.71	3.04	2.55	2.17	1.89	1.65	1.46	1.31	1.18	1.07	0.98	0.90	0.76
16	0.35	1.49	2.52	3.27	4.71	6.33	5.15	4.09	3.35	2.80	2.40	2.08	1.82	1.62	1.45	1.30	1.18	1.09	0.99	0.84
17	0.38	1.58	2.69	3.49	5.03	6.76	5.64	4.48	3.66	3.07	2.63	2.28	2.00	1.77	1.58	1.43	1.30	1.18	1.09	0.92
18	0.40	1.69	2.87	3.71	5.35	7.18	6.15	4.88	3.99	3.35	2.86	2.48	2.17	1.93	1.73	1.55	1.41	1.29	1.18	1.01
19	0.42	1.78	3.04	3.94	5.67	7.61	6.66	5.29	4.33	3.63	3.10	2.68	2.36	2.09	1.88	1.69	1.53	1.39	1.29	1.10
20	0.44	1.89	3.20	4.16	5.99	8.06	7.20	5.71	4.68	3.91	3.35	2.90	2.55	2.25	2.02	1.82	1.65	1.51	1.38	1.18
21	0.47	2.00	3.38	4.38	6.31	8.49	7.75	6.15	5.03	4.22	3.61	3.12	2.73	2.43	2.17	1.96	1.78	1.62	1.49	1.27
22	0.50	2.09	3.55	4.61	6.64	8.93	8.31	6.60	5.40	4.52	3.86	3.35	2.94	2.60	2.33	2.10	1.90	1.74	1.60	1.37
23	0.52	2.20	3.73	4.84	6.97	9.36	8.89	7.05	5.76	4.84	4.13	3.58	3.14	2.79	2.49	2.25	2.04	1.86	1.70	1.46
24	0.54	2.31	3.91	5.07	7.29	9.80	9.46	7.51	6.15	5.15	4.40	3.81	3.35	2.96	2.65	2.40	2.17	1.98	1.82	1.55
25	0.56	2.41	4.09	5.29	7.63	10.20	10.10	7.99	6.54	5.48	4.68	4.05	3.55	3.15	2.83	2.55	2.31	2.10	1.93	1.65
28	0.64	2.72	4.61	5.98	8.62	11.60	11.90	9.46	7.75	6.49	5.55	4.80	4.22	3.74	3.35	3.02	2.73	2.51	2.29	1.96
30	0.68	2.94	4.97	6.45	9.28	12.50	13.20	10.50	8.59	7.20	6.15	5.34	4.68	4.14	3.71	3.35	3.04	2.77	2.55	2.17
32	0.74	3.14	5.34	6.90	9.95	13.40	14.60	11.60	9.46	7.94	6.77	5.87	5.15	4.57	4.09	3.69	3.35	3.06	2.80	2.40
35	0.82	3.46	5.87	7.61	11.00	14.70	16.60	13.20	10.80	9.08	7.75	6.72	5.90	5.23	4.68	4.22	3.83	3.50	3.20	
40	0.94	3.99	6.78	8.79	12.70	17.00	20.10	16.20	13.20	11.10	9.46	8.20	7.20	6.38	5.71	5.15	4.68			
45	1.07	4.54	7.47	9.99	14.30	19.30	22.80	19.30	15.80	13.20	11.30	9.79	8.59	7.61	6.82	6.15				
50	1.19	5.09	8.63	11.20	16.10	21.70	25.50	22.70	18.50	15.50	13.20	11.50	10.10	8.93						
55	1.33	5.64	9.57	12.40	17.80	24.00	28.30	26.00	21.30	17.80	15.30	13.20	11.60							
60	1.46	6.19	10.50	13.70	19.60	26.40	31.10	29.80	24.30	20.40	17.40									

Note: Value in above table is for single strand chain only.

For multiplex chain, please apply the coefficient of Multi-strand. Please refer to chain selection on P.64.

RC41 Standard Roller Chain

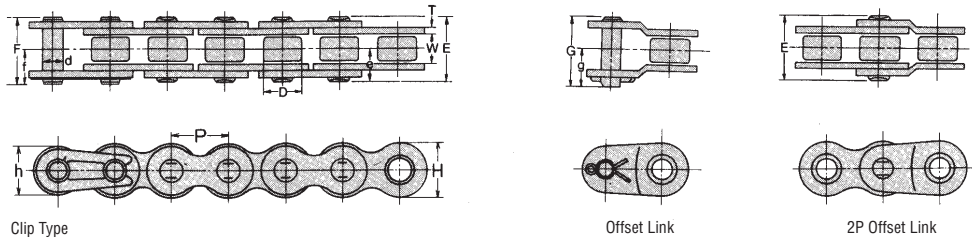

Dimensions

Chain No.		Pitch P	Roller Link Width W	Roller Dia. D	Pin							Plate			JIS Min. Tensile Strength lbs	DID Min. Tensile Strength lbs	DID Avg. Tensile Strength lbs	DID Max. Allowable Load lbs	Approx. Weight (lbs/ft)
DID	ANSI				d	E	F	G	e	f	g	T	H	h					
RC41	41	0.500	0.251	0.306	0.141	0.539	0.575	0.602	0.272	0.311	0.335	0.047	0.378	0.315	1503	1980	2420	528	0.26

Max. Horsepower Ratings

Type of Lubrication No. of Teeth of Small Sprocket	Revolutions per minute-Small Sprocket (rpm) (Please refer to P.76 for more details regarding type of lubrication A, B and C.)																			
	50	200	400	600	900	1200	1800	2400	3000	3500	4000	4500	5000	5500	6000	6500	7000	7500	8000	9000
	A							B					C							
11	0.15	0.54	0.99	1.42	2.05	1.72	0.92	0.60	0.43	0.35	0.28	0.24	0.20	0.17	0.15	0.13	0.12	0.11	0.09	
12	0.16	0.58	1.09	1.57	2.25	1.94	1.06	0.68	0.50	0.39	0.32	0.27	0.23	0.20	0.17	0.16	0.13	0.12	0.11	
13	0.19	0.63	1.18	1.70	2.47	2.20	1.19	0.78	0.55	0.44	0.36	0.31	0.25	0.23	0.20	0.17	0.16	0.13	0.13	
14	0.20	0.68	1.29	1.85	2.67	2.45	1.34	0.87	0.62	0.50	0.40	0.34	0.29	0.25	0.21	0.20	0.17	0.16	0.15	
15	0.21	0.74	1.38	2.00	2.87	2.72	1.49	0.97	0.68	0.55	0.44	0.38	0.32	0.28	0.24	0.21	0.19	0.17		
16	0.23	0.79	1.49	2.13	3.08	3.00	1.64	1.06	0.76	0.60	0.50	0.42	0.35	0.31	0.27	0.24	0.21	0.19		
17	0.24	0.84	1.58	2.28	3.28	3.28	1.78	1.17	0.83	0.66	0.54	0.46	0.39	0.34	0.29	0.25	0.23	0.21		
18	0.25	0.90	1.69	2.43	3.50	3.58	1.94	1.26	0.91	0.72	0.59	0.50	0.42	0.36	0.32	0.28	0.25	0.23		
19	0.28	0.95	1.78	2.57	3.71	3.89	2.12	1.37	0.98	0.78	0.64	0.54	0.46	0.40	0.35	0.31	0.28	0.25		
20	0.29	1.02	1.89	2.72	3.91	4.20	2.28	1.49	1.06	0.84	0.68	0.58	0.50	0.43	0.38	0.34	0.29	0.27		
21	0.31	1.07	2.00	2.87	4.13	4.50	2.45	1.60	1.14	0.91	0.74	0.62	0.54	0.46	0.40	0.36	0.32	0.29		
22	0.32	1.13	2.09	3.02	4.34	4.84	2.63	1.72	1.22	0.97	0.79	0.67	0.56	0.50	0.43	0.39	0.35			
23	0.34	1.18	2.20	3.16	4.56	5.17	2.82	1.82	1.31	1.03	0.84	0.71	0.60	0.52	0.46	0.42	0.36			
24	0.35	1.23	2.31	3.31	4.77	5.51	3.00	1.94	1.39	1.11	0.91	0.76	0.64	0.56	0.50	0.44	0.39			
25	0.38	1.29	2.40	3.46	4.99	5.86	3.19	2.06	1.49	1.18	0.97	0.80	0.68	0.60	0.52	0.47				
28	0.42	1.46	2.72	3.91	5.63	6.94	3.78	2.45	1.76	1.39	1.14	0.95	0.82	0.71	0.62	0.55				
30	0.46	1.57	2.92	4.21	6.07	7.69	4.20	2.72	1.94	1.54	1.26	1.06	0.91	0.79	0.68					
32	0.48	1.68	3.14	4.52	6.51	8.43	4.61	3.00	2.14	1.70	1.39	1.17	0.99	0.86	0.76					
35	0.54	1.85	3.46	4.97	7.17	9.29	5.28	3.43	2.45	1.94	1.60	1.34	1.14	0.99						
40	0.62	2.14	3.99	5.75	8.28	10.70	6.45	4.20	3.00	2.39	1.94	1.64	1.39							
45	0.70	2.43	4.53	6.53	9.41	12.20	7.69	5.00	3.58	2.84	2.32	1.94								
50	0.78	2.72	5.08	7.32	10.50	13.70	9.02	5.86	4.20	3.32	2.72									
55	0.87	3.02	5.63	8.11	11.70	15.10	10.40	6.76	4.84	3.83										
60	0.95	3.31	6.18	8.91	12.80	16.60	11.80	7.69	5.51											

Note: Value in above table is for single strand chain only.

For multiplex chain, please apply the coefficient of Multi-strand. Please refer to chain selection on P.64.

RC40 Standard Roller Chain

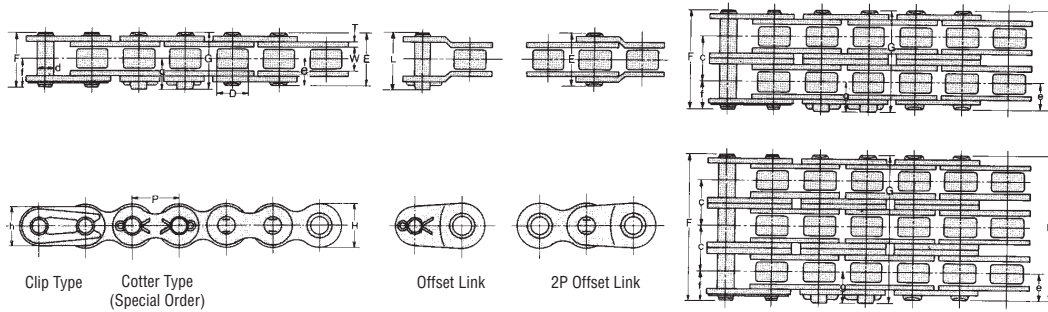

Dimensions

Chain No.		Pitch P	Roller Link Width W	Roller Dia. D	Pin									Transverse Pitch C	Plate			JIS Min. Tensile Strength lbs	DID Min. Tensile Strength lbs	DID Avg. Tensile Strength lbs	DID Max. Allowable Load lbs	Approx. Weight (lbs/ft)
DID	ANSI				d	E	F	G	L	e	f	g	T		H	h						
RC40	40	0.500	0.313	0.312	0.156	0.650	0.693	0.713	0.752	0.327	0.374	0.398	0.567	0.059	0.472	0.409	3095	3520	4290	836	0.42	
RC40-2	40-2					1.220	1.264	1.283	1.323								6191	7040	8580	1408	0.80	
RC40-3	40-3					1.787	1.827	1.850	1.886								9286	10560	12870	2090	1.19	
RC40-4	40-4					2.358	2.402	2.417	2.417								12382	14080	17160	2750	1.59	
RC40-5	40-5					2.925	2.969	2.984	2.984								15477	17600	21450	3256	1.98	

Max. Horsepower Ratings

Type of Lubrication No. of Teeth of Small Sprocket	Revolutions per minute-Small Sprocket (rpm) (Please refer to P.76 for more details regarding type of lubrication A, B and C.)																								
	50					200					400					600					900				
	A					B					C														
11	0.27	0.94	1.74	2.52	3.63	4.71	4.66	3.03	2.17	1.72	1.41	1.18	1.01	0.87	0.76	0.68	0.60	0.55	0.50						
12	0.29	1.03	1.92	2.76	3.98	5.16	5.31	3.45	2.47	1.96	1.61	1.34	1.15	0.99	0.87	0.78	0.70	0.63	0.56						
13	0.32	1.13	2.09	3.02	4.34	5.63	5.99	3.89	2.79	2.21	1.81	1.51	1.30	1.13	0.98	0.87	0.78	0.71	0.64						
14	0.35	1.22	2.27	3.27	4.71	6.10	6.70	4.34	3.11	2.47	2.02	1.69	1.45	1.26	1.10	0.98	0.87	0.79	0.71						
15	0.38	1.31	2.44	3.53	5.07	6.57	7.43	4.83	3.45	2.73	2.24	1.88	1.61	1.39	1.22	1.09	0.97	0.87							
16	0.40	1.41	2.63	3.78	5.44	7.05	8.18	5.31	3.81	3.02	2.47	2.06	1.77	1.53	1.34	1.19	1.07	0.97							
17	0.43	1.50	2.80	4.03	5.80	7.52	8.95	5.82	4.17	3.31	2.71	2.27	1.93	1.68	1.47	1.30	1.17	1.06							
18	0.46	1.60	2.98	4.29	6.18	8.00	9.76	6.34	4.53	3.61	2.95	2.47	2.10	1.82	1.61	1.42	1.27	1.15							
19	0.48	1.69	3.15	4.54	6.55	8.49	10.60	6.88	4.92	3.90	3.19	2.68	2.29	1.98	1.74	1.54	1.38	1.25							
20	0.51	1.78	3.34	4.80	6.92	8.97	11.40	7.43	5.31	4.22	3.45	2.90	2.47	2.14	1.88	1.66	1.49	1.34							
21	0.54	1.89	3.51	5.07	7.29	9.45	12.30	7.99	5.72	4.53	3.71	3.11	2.65	2.31	2.02	1.80	1.61	1.45							
22	0.56	1.98	3.70	5.32	7.67	9.93	13.20	8.57	6.13	4.87	3.98	3.34	2.86	2.47	2.17	1.92	1.72								
23	0.60	2.08	3.87	5.59	8.04	10.40	14.10	9.16	6.55	5.20	4.26	3.57	3.04	2.64	2.32	2.05	1.84								
24	0.63	2.17	4.06	5.86	8.43	10.90	15.00	9.76	6.98	5.55	4.53	3.81	3.24	2.82	2.47	2.18	1.96								
25	0.66	2.28	4.25	6.11	8.81	11.40	16.00	10.40	7.43	5.90	4.83	4.05	3.45	2.99	2.63	2.33									
28	0.74	2.57	4.80	6.92	9.96	12.90	18.60	12.30	8.81	6.98	5.72	4.79	4.09	3.55	3.11	2.76									
30	0.79	2.77	5.17	7.44	10.70	13.90	20.00	13.70	9.76	7.75	6.34	5.31	4.53	3.93	3.45										
32	0.86	2.98	5.54	7.99	11.50	14.90	21.40	15.00	10.80	8.54	6.98	5.86	5.00	4.33	3.81										
35	0.94	3.27	6.10	8.79	12.70	16.40	23.60	17.20	12.30	9.76	7.99	6.70	5.72	4.96											
40	1.09	3.78	7.05	10.20	14.60	18.90	27.30	21.00	15.00	11.90	9.76	8.18	6.98												
45	1.23	4.29	8.02	11.50	16.60	21.60	31.00	25.10	18.00	14.20	11.60	9.76													
50	1.38	4.81	8.98	12.90	18.60	24.10	34.70	29.40	21.00	16.60	13.70														
55	1.53	5.34	9.95	14.30	20.60	26.80	38.50	33.90	24.30	19.30															
60	1.68	5.86	10.90	15.70	22.70	29.40	42.40	38.60	27.60																

Note: Value in above table is for single strand chain only.

For multiplex chain, please apply the coefficient of Multi-strand. Please refer to chain selection on P.64.

RC50 Standard Roller Chain

TRANSMISSION
ROLLER CHAIN

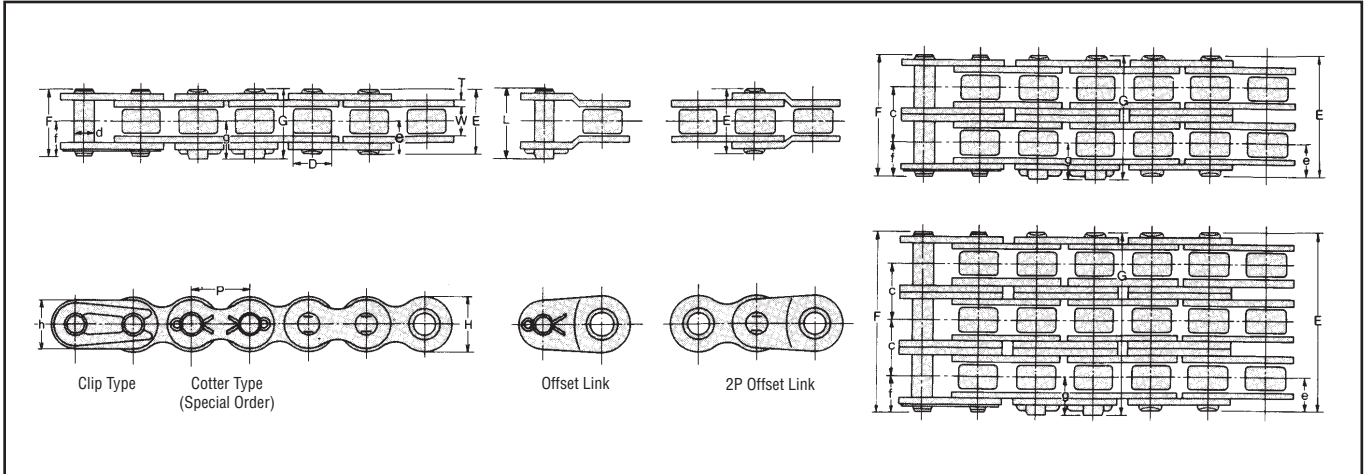

Dimensions

Unit (inch)

Chain No.	Pitch	Roller Link Width	Roller Dia.	Pin									Transverse Pitch	Plate				JIS Min. Tensile Strength	DID Min. Tensile Strength	DID Avg. Tensile Strength	DID Max. Allowable Load	Approx. Weight (lbs/ft)
				D	d	E	F	G	L	e	f	g		C	T	H	h					
RC50	50	0.625	0.375	0.400	0.200	0.799	0.862	0.870	0.913	0.402	0.457	0.476	0.713	0.079	0.591	0.512	4891	5940	6930	1540	0.71	
RC50-2	50-2					1.516	1.579	1.587	1.626								9781	11880	13860	2618	1.37	
RC50-3	50-3					2.232	2.295	2.303	2.343								14672	17820	20790	3850	2.05	
RC50-4	50-4					2.945	3.008	3.016	3.016								19562	23760	27720	5082	2.72	
RC50-5	50-5					3.661	3.720	3.728	3.728								24453	29700	34650	6006	3.41	

Max. Horsepower Ratings

Unit (hp)

Type of Lubrication No. of Teeth of Small Sprocket	Revolutions per minute-Small Sprocket (rpm) (Please refer to P.76 for more details regarding type of lubrication A, B and C.)																			
	A					B					C									
	50	100	300	500	900	1200	1500	1800	2100	2400	2700	3000	3300	3500	4000	4500	5000	5400	5800	6200
11	0.64	1.21	3.24	5.13	8.70	10.20	7.33	5.58	4.42	3.62	3.03	2.59	2.25	2.05	1.69	1.41	1.21	1.07	0.97	
12	0.71	1.33	3.55	5.63	9.56	11.70	8.35	6.35	5.04	4.13	3.46	2.95	2.56	2.35	1.92	1.61	1.37	1.22	1.10	
13	0.78	1.45	3.87	6.14	10.40	13.20	9.41	7.16	5.68	4.65	3.90	3.32	2.88	2.64	2.16	1.81	1.54	1.38	1.23	
14	0.84	1.57	4.21	6.65	11.30	14.60	10.50	8.00	6.35	5.20	4.36	3.73	3.23	2.95	2.41	2.02	1.73	1.54		
15	0.90	1.69	4.53	7.17	12.20	15.80	11.70	8.87	7.05	5.76	4.84	4.13	3.58	3.27	2.68	2.25	1.92	1.70		
16	0.97	1.81	4.85	7.69	13.00	16.90	12.90	9.79	7.76	6.35	5.32	4.54	3.94	3.61	2.95	2.48	2.12	1.88		
17	1.03	1.93	5.19	8.20	13.90	18.10	14.10	10.70	8.50	6.96	5.83	4.97	4.32	3.95	3.23	2.71	2.32	2.06		
18	1.10	2.05	5.51	8.73	14.90	19.20	15.30	11.70	9.26	7.57	6.35	5.43	4.71	4.30	3.53	2.95	2.52			
19	1.17	2.17	5.84	9.25	15.70	20.40	16.60	12.70	10.00	8.22	6.89	5.88	5.09	4.66	3.82	3.20	2.73			
20	1.23	2.29	6.18	9.79	16.60	21.60	18.00	13.70	10.80	8.87	7.44	6.35	5.51	5.04	4.13	3.46	2.95			
21	1.30	2.43	6.51	10.30	17.60	22.70	19.30	14.70	11.70	9.56	8.00	6.84	5.92	5.43	4.44	3.73	3.18			
22	1.37	2.55	6.85	10.80	18.40	23.90	20.80	15.80	12.50	10.20	8.58	7.33	6.35	5.82	4.76	3.99	3.40			
23	1.43	2.67	7.18	11.40	19.30	25.10	22.10	16.90	13.40	11.00	9.17	7.83	6.80	6.22	5.09	4.26				
24	1.50	2.80	7.52	11.90	20.20	26.10	23.60	18.00	14.20	11.70	9.79	8.35	7.24	6.62	5.43	4.54				
25	1.57	2.92	7.86	12.50	21.20	27.30	25.10	19.20	15.10	12.40	10.40	8.87	7.69	7.05	5.76	4.84				
28	1.77	3.31	8.89	14.10	23.90	31.00	29.80	22.70	18.00	14.70	12.30	10.50	9.12	8.35	6.84					
30	1.90	3.57	9.57	15.10	25.70	33.40	33.00	25.10	20.00	16.40	13.70	11.70	10.10	9.26	7.57					
32	2.05	3.82	10.30	16.20	27.60	35.80	36.30	27.60	22.00	18.00	15.00	12.90	11.10	10.20	8.35					
35	2.25	4.21	11.30	18.00	30.40	39.40	41.60	31.60	25.10	20.50	17.30	14.70	12.70	11.70	9.56					
40	2.60	4.85	13.10	20.60	35.10	45.40	50.80	38.60	30.70	25.10	21.00	18.00	15.50	14.20						
45	2.96	5.52	14.90	23.50	39.80	51.60	60.60	46.10	36.60	30.00	25.10	21.40	18.60							
50	3.31	6.18	16.60	26.30	44.60	57.90	70.80	54.00	42.90	35.10	29.40	25.10								
55	3.67	6.85	18.40	29.20	49.50	64.20	78.40	62.30	49.50	40.50	33.90									
60	4.03	7.53	20.20	32.00	54.40	70.50	86.20	71.00	56.40	46.10										

Note: Value in above table is for single strand chain only.

For multiplex chain, please apply the coefficient of Multi-strand. Please refer to chain selection on P.64.

RC60 Standard Roller Chain

TRANSMISSION ROLLER CHAIN

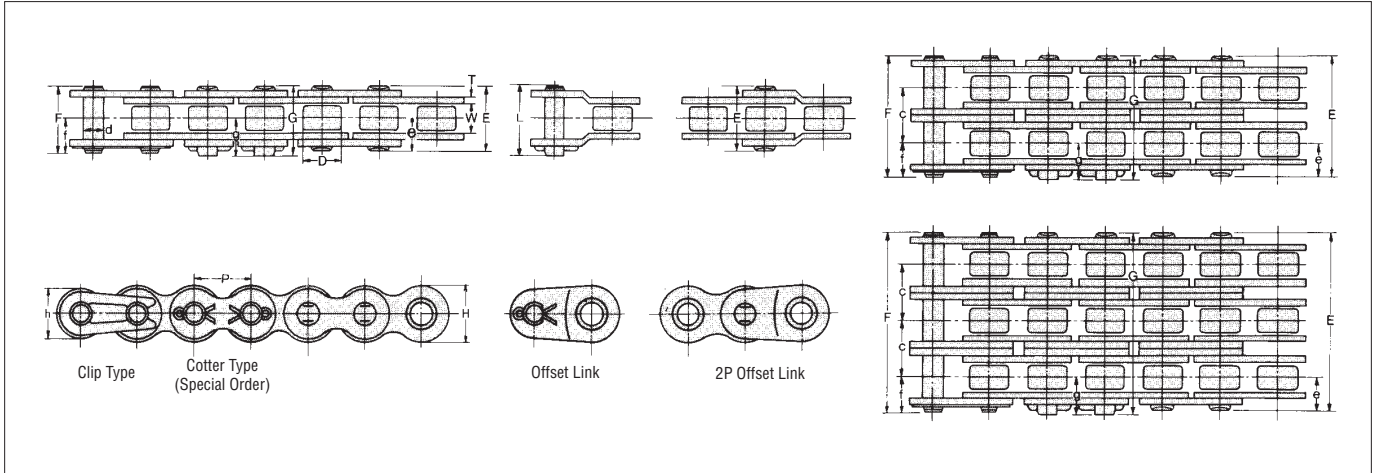

Dimensions

Chain No.		Pitch P	Roller Link Width W	Roller Dia. D	Pin							Transverse Pitch C	Plate			JIS Min. Tensile Strength lbs	DID Min. Tensile Strength lbs	DID Avg. Tensile Strength lbs	DID Max. Allowable Load lbs	Approx. Weight (lbs/ft)	
DID	ANSI				d	E	F	G	L	e	f		g	T	H						h
RC60	60	0.750	0.500	0.469	0.235	1.000	1.059	1.098	1.173	0.500	0.563	0.594	0.898	0.094	0.713	0.614	6978	7920	9900	2090	0.97
RC60-2	60-2					1.902	1.961	2.004	2.067								13957	15840	19800	3542	2.03
RC60-3	60-3					2.803	2.862	2.902	2.965								20935	23760	29700	5214	3.02
RC60-4	60-4					3.701	3.760	3.799	3.799								27914	31680	39600	6886	4.04
RC60-5	60-5					4.598	4.677	4.697	4.697								34892	39600	49500	8140	5.05

Max. Horsepower Ratings

Type of Lubrication No. of Teeth of Small Sprocket	Revolutions per minute-Small Sprocket (rpm) (Please refer to P.76 for more details regarding type of lubrication A, B and C.)																							
	50					100					200					400					600			
	A					B					C													
11	1.01	1.88	3.51	8.02	10.80	13.70	11.80	9.41	7.69	6.45	5.51	4.77	4.20	3.71	3.32	3.00	2.37	2.10	1.94					
12	1.11	2.06	3.86	8.81	11.90	15.00	13.50	10.70	8.77	7.35	6.27	5.44	4.77	4.24	3.79	3.42	2.71	2.40	2.23					
13	1.21	2.25	4.21	9.60	13.00	16.40	15.30	12.10	9.89	8.28	7.08	6.14	5.39	4.77	4.28	3.85	3.06	2.71	2.51					
14	1.31	2.44	4.56	10.40	14.10	17.70	17.00	13.50	11.00	9.26	7.91	6.85	6.02	5.34	4.77	4.30	3.42	3.02	2.80					
15	1.41	2.63	4.91	11.20	15.10	19.00	18.90	15.00	12.30	10.30	8.77	7.60	6.68	5.91	5.29	4.77	3.79	3.35	3.10					
16	1.51	2.83	5.27	12.00	16.20	20.40	20.80	16.50	13.50	11.30	9.66	8.38	7.35	6.51	5.83	5.25	4.17	3.69	3.42					
17	1.61	3.02	5.62	12.80	17.40	21.70	22.80	18.10	14.70	12.40	10.60	9.17	8.06	7.14	6.39	5.76	4.57	4.03	3.74					
18	1.72	3.20	5.98	13.70	18.50	23.20	24.80	19.70	16.10	13.50	11.50	9.99	8.77	7.77	6.96	6.27	4.99	4.40	4.08					
19	1.82	3.39	6.34	14.50	19.60	24.50	26.90	21.30	17.40	14.60	12.50	10.80	9.52	8.43	7.55	6.81	5.40	4.77	4.42					
20	1.93	3.59	6.70	15.30	20.60	26.00	29.10	23.10	18.90	15.80	13.50	11.70	10.30	9.12	8.15	7.35	5.83	5.16						
21	2.02	3.78	7.06	16.10	21.80	27.30	31.20	24.80	20.40	17.00	14.50	12.60	11.00	9.80	8.77	7.91	6.27	5.55						
22	2.13	3.98	7.43	16.90	22.90	28.80	33.50	26.70	21.70	18.20	15.50	13.50	11.80	10.50	9.41	8.49	6.73	5.95						
23	2.24	4.18	7.79	17.80	24.10	30.20	35.80	28.40	23.30	19.60	16.60	14.50	12.70	11.20	10.10	9.06	7.20							
24	2.35	4.37	8.16	18.60	25.20	31.60	38.20	30.30	24.80	20.80	17.70	15.40	13.50	12.00	10.70	9.66	7.67							
25	2.45	4.57	8.53	19.40	26.30	33.00	40.60	32.20	26.40	22.10	18.90	16.40	14.30	12.70	11.40	10.30	8.15							
28	2.76	5.16	9.64	22.00	29.80	37.30	48.10	38.20	31.20	26.10	22.40	19.40	17.00	15.10	13.50	12.20	9.66							
30	2.98	5.56	10.40	23.70	32.00	40.20	52.10	42.40	34.70	29.10	24.80	21.40	18.90	16.80	15.00	13.50								
32	3.19	5.97	11.10	25.30	34.30	43.20	55.90	46.60	38.20	32.00	27.30	23.70	20.80	18.50	16.50	14.90								
35	3.53	6.57	12.30	28.00	37.90	47.50	61.50	53.40	43.70	36.60	31.20	27.10	23.70	21.00	18.90	17.00								
40	4.06	7.59	14.20	32.30	43.70	54.80	71.00	65.30	53.40	44.80	38.20	33.10	29.10	25.70	23.10									
45	4.62	8.62	16.10	36.70	49.70	62.30	80.70	77.90	63.70	53.40	45.60	39.50	34.70	30.70										
50	5.17	9.66	18.10	41.20	55.60	69.80	90.50	91.20	74.70	62.50	53.40	46.20	40.60											
55	5.74	10.70	20.00	45.60	61.70	77.30	100	105.00	86.10	72.10	61.50	53.40												
60	6.30	11.80	22.00	50.10	67.80	85.00	110	120	98.10	82.20	70.10													

Note: Value in above table is for single strand chain only.
For multiplex chain, please apply the coefficient of Multi-strand. Please refer to chain selection on P.64.

RC80 Standard Roller Chain

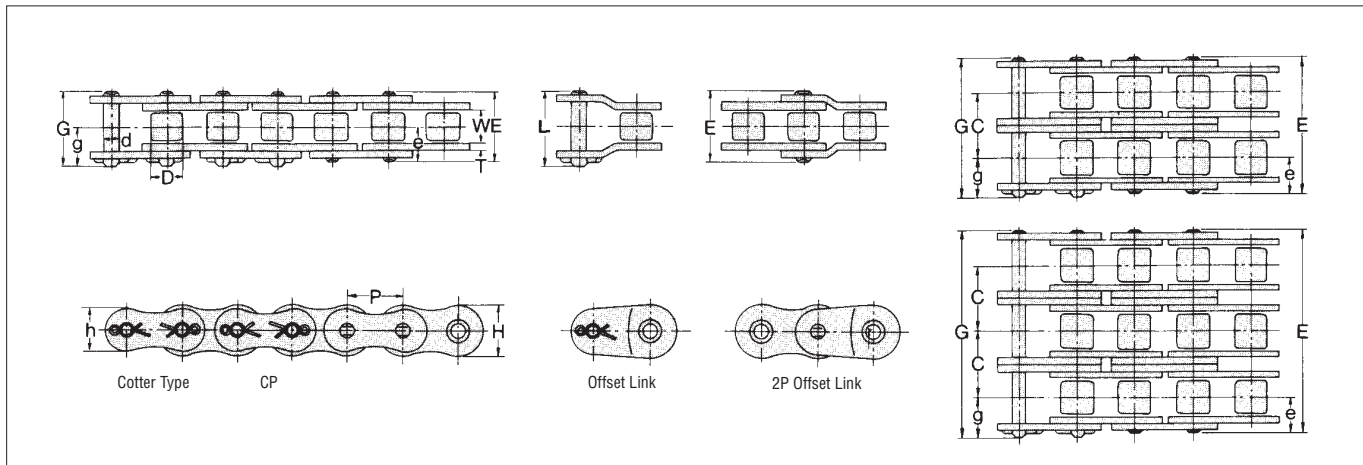

Dimensions

Chain No.	Pitch	Roller Link Width	Roller Dia.	Pin							Transverse Pitch	Plate			JIS Min. Tensile Strength	DID Min. Tensile Strength	DID Avg. Tensile Strength	DID Max. Allowable Load	Approx. Weight (lbs/ft)
				D	d	E	G	L	e	g		T	H	h					
RC80	80	1.000	0.625	0.625	0.313	1.283	1.394	1.461	0.646	0.748	1.154	0.126	0.945	0.819	12474	16060	17600	3300	1.71
RC80-2	80-2					2.437	2.547	2.610							24948	32120	35200	5610	3.40
RC80-3	80-3					3.594	3.701	3.744							37422	48180	52800	8250	5.08
RC80-4	80-4					4.748	4.854	4.898							49896	64240	70400	10890	6.77
RC80-5	80-5					5.902	6.008	6.051							62370	80300	88000	12870	8.45

Max. Horsepower Ratings

No. of Teeth of Small Sprocket	Revolutions per minute-Small Sprocket (rpm) (Please refer to P.76 for more details regarding type of lubrication A, B and C.)																																
	25							50							100							200						300					
	A			B				C				A			B				C				A			B			C				
11	1.51	2.84	5.29	9.88	14.20	18.50	22.50	30.60	22.90	19.60	14.90	11.80	9.69	8.12	6.93	6.01	5.27	4.68	4.42	4.18	3.78	3.43	3.12										
12	1.68	3.12	5.82	10.90	15.70	20.20	24.80	33.50	26.10	22.40	17.00	13.50	11.00	9.25	7.90	6.85	6.01	5.34	5.04	4.77	4.30	3.90	3.57										
13	1.82	3.40	6.34	11.80	17.00	22.10	26.90	36.60	29.50	25.20	19.20	15.30	12.50	10.40	8.90	7.72	6.77	6.01	5.68	5.38	4.85	4.40	4.02										
14	1.97	3.69	6.88	12.80	18.50	24.00	29.20	39.50	33.00	28.20	21.40	17.00	13.90	11.70	9.96	8.63	7.57	6.72	6.34	6.01	5.42	4.92	4.49										
15	2.13	3.97	7.40	13.80	19.80	25.70	31.50	42.60	36.60	31.20	23.70	18.90	15.40	12.90	11.00	9.57	8.40	7.45	7.04	6.66	6.01	5.46											
16	2.28	4.25	7.94	14.90	21.30	27.60	33.80	45.70	40.30	34.50	26.10	20.80	17.00	14.20	12.20	10.50	9.25	8.20	7.75	7.35	6.62	6.01											
17	2.44	4.54	8.47	15.80	22.80	29.50	36.10	48.80	44.10	37.00	28.70	22.80	18.60	15.50	13.30	11.50	10.10	8.98	8.50	8.04	7.25	6.58											
18	2.59	4.83	9.01	16.90	24.30	31.40	38.30	51.90	48.10	41.00	31.20	24.80	20.20	17.00	14.50	12.60	11.00	9.79	9.25	8.77	7.90	7.17											
19	2.75	5.12	9.56	17.80	25.70	33.20	40.60	55.10	52.10	44.50	33.90	26.90	22.00	18.50	15.70	13.70	12.00	10.60	10.00	9.50	8.57												
20	2.90	5.42	10.10	18.90	27.20	35.10	43.00	58.20	56.30	48.10	36.60	29.10	23.70	20.00	17.00	14.70	12.90	11.50	10.80	10.30	9.25												
21	3.06	5.71	10.60	19.80	28.70	37.10	45.30	61.40	60.60	51.70	39.40	31.20	25.60	21.40	18.20	15.80	13.90	12.30	11.70	11.00	9.96												
22	3.22	6.01	11.20	20.90	30.20	39.00	47.70	64.50	65.00	55.50	42.20	33.50	27.30	22.90	19.60	17.00	14.90	13.20	12.50	11.80	10.70												
23	3.38	6.30	11.70	22.00	31.60	40.90	50.00	67.70	69.40	59.20	45.20	35.80	29.40	24.50	20.90	18.20	16.00	14.20	13.40	12.70	4.91												
24	3.53	6.60	12.30	22.90	33.10	42.80	52.40	70.90	74.00	63.30	48.10	38.20	31.20	26.10	22.40	19.40	17.00	15.10	14.20	13.50													
25	3.69	6.89	12.90	24.00	34.60	44.80	54.70	74.00	78.70	67.20	51.10	40.60	33.20	27.90	23.70	20.60	18.10	16.10	15.10	14.30													
28	4.17	7.79	14.50	27.10	39.00	50.50	61.80	83.60	93.30	79.60	60.60	48.10	39.40	33.00	28.20	24.40	21.40	19.00	18.00														
30	4.49	8.39	15.70	29.20	42.10	53.80	66.60	88.30	97.20	83.30	67.20	53.40	43.70	36.60	31.20	27.10	23.70	21.00	8.08														
32	4.81	8.99	16.80	31.40	45.00	58.40	71.40	96.60	114	97.30	74.00	58.70	48.10	40.30	34.50	29.80	26.10																
35	5.31	9.91	18.50	34.50	49.70	64.30	78.70	107	130	111	84.70	67.20	55.00	46.10	39.40	34.00																	
40	6.13	11.40	21.30	39.80	57.40	74.40	90.90	123	154	135	103	82.00	67.20	56.30	48.10																		
45	6.96	13.00	24.30	45.30	65.10	84.50	103	139	176	162	123	98.00	80.20	67.20																			
50	7.80	14.60	27.20	50.70	73.10	94.60	116	157	196	190	145	115	94.00																				
55	8.65	16.10	30.20	56.20	81.00	105	128	173	217	220	166	132																					
60	9.50	17.70	33.10	61.80	88.90	115	141	190	239	249	190																						

Note: 1. Value in above table is for single strand chain only.

For multiplex chain, please apply the coefficient of Multi-strand. Please refer to chain selection on P.64.

2. Please consult with us when the ratings are to the right of the solid blue line.

RC100 Standard Roller Chain

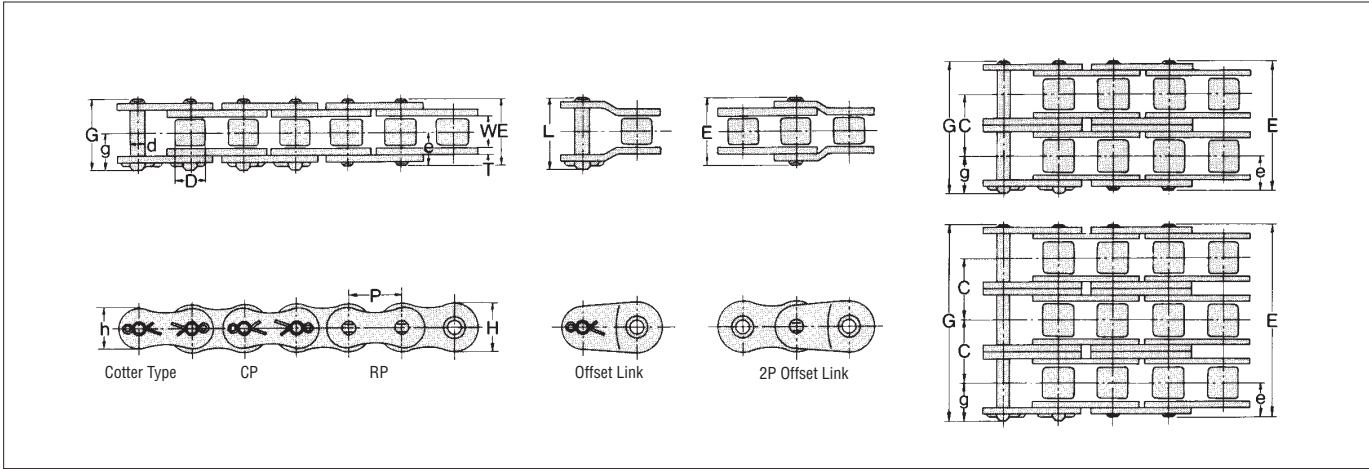

Dimensions

Unit (inch)

Chain No.		Pitch P	Roller Link Width W	Roller Dia. D	Pin						Transverse Pitch C	Plate			JIS Min. Tensile Strength lbs	DID Min. Tensile Strength lbs	DID Avg. Tensile Strength lbs	DID Max. Allowable Load lbs	Approx. Weight (lbs/FT)
DID	ANSI				d	E	G	L	e	g		T	H	h					
RC100	100	1.250	0.750	0.750	0.376	1.555	1.673	1.780	0.780	0.894	1.409	0.157	1.177	1.024	19450	24200	26620	5060	2.54
RC100-2	100-2					2.965	3.083	3.193							38900	48400	53240	8602	5.05
RC100-3	100-3					4.378	4.496	4.535							58351	72600	79860	12650	7.58
RC100-4	100-4					5.787	5.906	5.945							77801	96800	106480	16698	10.13
RC100-5	100-5					7.201	7.319	7.358							97251	121000	133100	19734	12.67

Max. Horsepower Ratings

Unit (hp)

No. of Teeth of Small Sprocket	Revolutions per minute-Small Sprocket (rpm) (Please refer to P.76 for more details regarding type of lubrication A, B and C.)																										
	A							B							C												
	10	25	50	100	200	300	400	500	600	700	800	900	1000	1100	1200	1300	1400	1600	1800	2000	2200	2400	2500	2600	2700		
11	1.21	2.75	5.13	9.57	17.80	25.70	33.4	40.80	48.00	40.10	32.70	27.50	23.50	20.40	17.80	15.80	14.20	11.60	9.71	8.28	7.18	6.30	5.92	5.59	1.46		
12	1.33	3.02	5.63	10.50	19.60	28.30	36.6	44.80	52.80	45.60	37.40	31.20	26.70	23.20	20.40	18.00	16.10	13.20	11.10	9.44	8.19	7.18	6.76	6.37			
13	1.45	3.30	6.14	11.50	21.40	30.80	39.9	48.80	57.50	51.50	42.10	35.30	30.20	26.10	22.90	20.40	18.20	14.90	12.50	10.60	9.24	8.10	7.61	7.18			
14	1.57	3.57	6.66	12.40	23.20	33.40	43.3	52.90	62.30	57.50	47.10	39.40	33.60	29.20	25.60	22.70	20.40	16.60	13.90	11.90	10.30	9.05	8.51				
15	1.69	3.85	7.17	13.40	24.90	35.90	46.6	57.00	67.20	63.80	52.10	43.70	37.40	32.30	28.40	25.20	22.50	18.50	15.40	13.20	11.40	10.00	9.44				
16	1.81	4.12	7.69	14.30	26.80	38.60	50.0	61.10	72.00	70.20	57.50	48.10	41.20	35.70	31.20	27.70	24.80	20.40	17.00	14.60	12.60	11.10	10.40				
17	1.93	4.40	8.20	15.30	28.60	41.20	53.4	65.30	76.80	76.90	63.00	52.80	45.00	39.00	34.30	30.40	27.20	22.30	18.60	16.00	13.80	12.10					
18	2.05	4.68	8.73	16.40	30.40	43.80	56.7	69.40	81.80	83.80	68.60	57.50	49.10	42.50	37.40	33.10	29.60	24.30	20.40	17.30	15.00	13.20					
19	2.17	4.96	9.26	17.30	32.30	46.40	60.2	73.60	86.60	90.90	74.40	62.30	53.20	46.10	40.50	35.90	32.20	26.30	22.00	18.80	16.40	14.30					
20	2.29	5.24	9.79	18.20	34.00	49.10	63.5	77.70	91.60	98.10	80.40	67.30	57.50	49.90	43.70	38.70	34.70	28.40	23.90	20.40	17.60						
21	2.43	5.52	10.30	19.30	35.90	51.70	67.0	81.90	96.50	106	86.50	72.40	61.80	53.60	47.10	41.70	37.40	30.60	25.60	21.80	18.90						
22	2.55	5.82	10.80	20.20	37.80	54.40	70.5	86.20	101	113	92.60	77.60	66.40	57.50	50.40	44.80	40.10	32.70	27.50	23.50	20.40						
23	2.67	6.10	11.40	21.20	39.70	57.10	74.0	90.30	107	121	99.10	83.00	70.90	61.40	53.90	47.90	42.80	35.00	29.40	25.10	21.70						
24	2.80	6.38	11.90	22.30	41.60	59.80	77.5	94.60	112	128	106	88.50	75.60	65.50	57.50	50.90	45.60	37.40	31.20	26.70	23.20						
25	2.92	6.68	12.50	23.20	43.40	62.50	81.0	98.90	117	134	112	94.10	80.30	69.60	61.0	54.20	48.50	39.70	33.20	28.40	24.50						
28	3.31	7.55	14.10	26.30	49.10	70.60	91.4	112	132	151	133	112	95.20	82.60	72.40	64.20	57.50	47.10	39.40	33.60							
30	3.57	8.12	15.10	28.30	52.80	76.00	98.5	121	142	164	147	124	106	91.60	80.30	71.20	63.80	52.10	43.70								
32	3.82	8.71	16.20	30.30	56.60	81.50	106	129	153	174	162	137	116	101	88.50	78.40	70.20	57.50	48.10								
35	4.21	9.60	18.00	33.40	62.30	89.80	116	142	168	193	186	155	133	115	101	89.80	80.30	66.20									
40	4.87	11.10	20.60	38.60	72.00	104	134	165	193	223	227	190	162	141	124	110	98.10										
45	5.52	12.60	23.50	43.80	81.80	118	153	186	220	252	271	227	194	168	147	131											
50	6.18	14.10	26.30	49.20	91.70	132	172	209	247	283	318	265	227	197													
55	6.85	15.70	29.20	54.40	102	146	189	232	273	314	354	307	263														
60	7.53	17.20	32.00	59.80	112	161	208	255	300	345	389	350															

Note: Value in above table is for single strand chain only. For multiplex chain, please apply the coefficient of Multi-strand. Please refer to chain selection on P.64. Please consult with us when the ratings are to the right of the solid blue line.

RC120 Standard Roller Chain

TRANSMISSION
ROLLER CHAIN

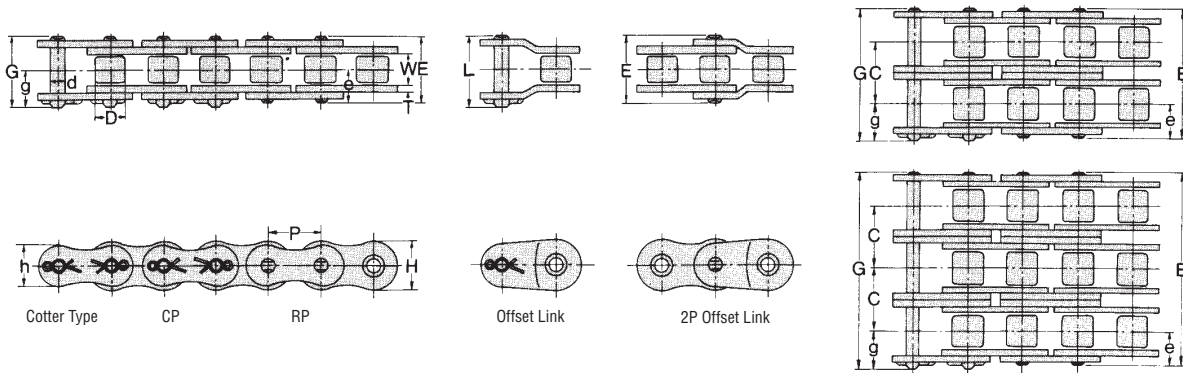

Dimensions

Unit (inch)

Chain No.	Pitch	Roller Link Width W	Roller Dia. D	Pin							Transverse Pitch C	Plate			JIS Min. Tensile Strength lbs	DID Min. Tensile Strength lbs	DID Avg. Tensile Strength lbs	DID Max. Allowable Load lbs	Approx. Weight (lbs/FT)
				d	E	G	L	e	g	T		H	h						
RC120	120	1.500	1.000	0.875	0.437	1.957	2.087	2.209	0.980	1.110	1.787	0.189	1.413	1.228	27953	33000	37400	6820	3.68
RC120-2	120-2					3.748	3.878	3.921							55906	66000	74800	11594	7.38
RC120-3	120-3					5.535	5.665	5.709							83860	99000	112200	17050	11.06
RC120-4	120-4					7.327	7.457	7.500							111813	132000	149600	22506	14.75
RC120-5	120-5					9.114	9.244	9.287							139766	165000	187000	26598	18.44

Max. Horsepower Ratings

Unit (hp)

No. of Teeth of Small Sprocket	Revolutions per minute-Small Sprocket (rpm) (Please refer to P.76 for more details regarding type of lubrication A, B and C.)																								
	Type of Lubrication					Revolutions per minute-Small Sprocket (rpm)																			
	10	25	50	100	150	200	300	400	500	600	700	800	900	1000	1100	1200	1300	1400	1500	1600	1700	1800	1900	2000	2100
11	2.02	4.62	8.65	16.10	23.20	30.20	43.30	56.20	68.60	58.30	46.40	37.90	31.80	27.10	23.50	20.60	18.40	16.40	14.70	13.40	12.20	11.20	10.40	9.58	8.91
12	2.23	5.08	9.49	17.70	25.50	33.10	47.60	61.70	75.50	66.50	52.80	43.20	36.20	31.00	26.80	23.50	20.90	18.60	16.90	15.30	13.90	12.80	11.80	10.90	
13	2.43	5.55	10.30	19.30	27.90	36.10	51.90	67.30	82.20	74.90	59.50	48.70	40.90	34.90	30.20	26.50	23.50	21.00	19.00	17.20	15.70	14.50	13.30	12.30	
14	2.63	6.01	11.20	20.90	30.20	39.00	56.30	72.90	89.00	83.80	66.50	54.40	45.60	39.00	33.80	29.60	26.30	23.50	21.20	19.30	17.60	16.10	14.90	13.80	
15	2.84	6.47	12.10	22.50	32.40	42.10	60.60	78.60	96.00	92.90	73.70	60.30	50.50	43.20	37.40	32.80	29.10	26.10	23.50	21.30	19.40	17.80	16.50		
16	3.04	6.94	12.90	24.10	34.90	45.00	65.00	84.20	103	102	81.20	66.50	55.80	47.60	41.30	36.20	32.20	28.70	25.90	23.50	21.40	19.70	18.20		
17	3.24	7.41	13.80	25.90	37.10	48.10	69.30	89.80	110	112	89.00	72.80	61.00	52.10	45.20	39.70	35.10	31.50	28.40	25.70	23.50	21.60	19.80		
18	3.46	7.88	14.70	27.50	39.50	51.20	73.70	95.60	117	122	96.90	79.40	66.50	56.80	49.20	43.20	38.30	34.30	31.00	28.00	25.60	23.50	21.70		
19	3.66	8.35	15.50	29.10	42.00	54.30	78.20	101	124	132	105	86.10	72.10	61.50	53.40	46.80	41.60	37.10	33.50	30.40	27.70	25.50			
20	3.87	8.83	16.50	30.70	44.20	57.40	82.70	107	131	143	114	92.90	77.90	66.50	57.60	50.50	44.90	40.20	36.20	32.80	30.00	27.50			
21	4.08	9.30	17.40	32.40	46.60	60.50	87.10	113	138	154	122	100	83.80	71.60	62.10	54.40	48.30	43.20	39.00	35.40	32.30	29.60			
22	4.29	9.79	18.20	34.00	49.10	63.70	91.70	119	145	165	131	107	89.80	76.70	66.50	58.30	51.70	46.40	41.80	37.90	34.60	31.80			
23	4.50	10.30	19.20	35.80	51.50	66.80	96.10	125	153	177	139	115	96.10	82.00	71.00	62.30	55.40	49.50	44.60	40.50	37.00				
24	4.72	10.80	20.10	37.40	53.90	69.80	101	130	160	188	149	122	102	87.40	75.70	66.50	59.00	52.80	47.60	43.20	39.40				
25	4.93	11.20	20.90	39.10	56.40	73.10	105	137	166	196	158	130	109	92.90	80.60	70.60	62.70	56.20	50.50	46.00	42.00				
28	5.56	12.70	23.70	44.20	63.70	82.60	119	154	188	221	188	154	129	110	95.40	83.80	74.30	66.50	59.90	54.40					
30	5.99	13.70	25.60	47.70	68.60	88.90	128	166	202	239	209	170	143	122	106	92.90	82.40	73.70	66.50						
32	6.43	14.60	27.30	51.10	73.60	95.30	137	178	217	256	229	188	158	134	117	102	90.80	81.20							
35	7.09	16.20	30.20	56.30	81.10	105	151	196	240	283	263	214	181	155	133	117	104								
40	8.19	18.60	34.90	65.00	93.70	121	174	227	276	326	322	263	220	188	164										
45	9.29	21.20	39.50	73.90	106	138	198	257	314	370	383	314	263	224											
50	10.40	23.70	44.40	82.70	119	154	223	288	353	416	449	367	308												
55	11.50	26.30	49.20	91.70	132	172	247	319	390	460	517	424													
60	12.70	29.00	54.00	101	145	188	271	351	429	505	580														

Note: Value in above table is for single strand chain only. For multiplex chain, please apply the coefficient of Multi-strand. Please refer to chain selection on P.64. Please consult with us when the ratings are to the right of the solid blue line.

RC160 Standard Roller Chain

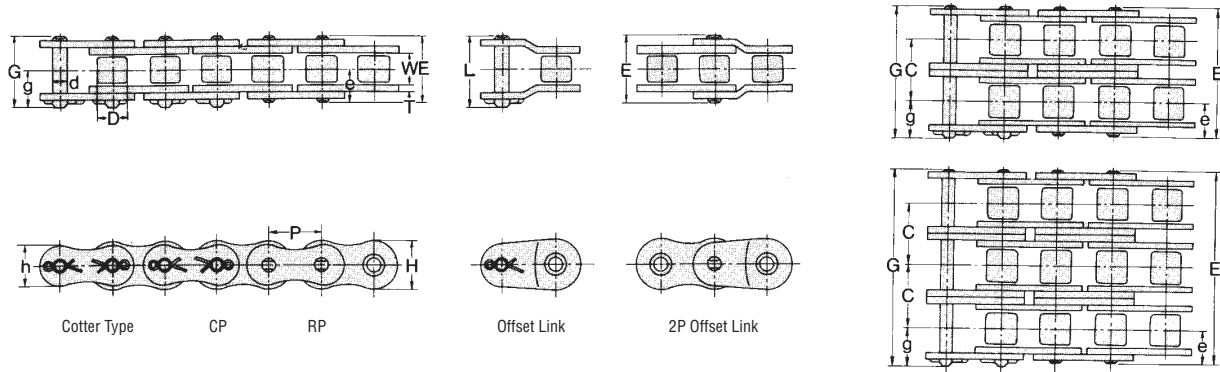

Dimensions

Chain No.		Pitch	Roller Link Width	Roller Dia.	Pin						Transverse Pitch	Plate				JIS Min. Tensile Strength	DID Min. Tensile Strength	DID Avg. Tensile Strength	DID Max. Allowable Load	Approx. Weight
DID	ANSI	P	W	D	d	E	G	L	e	g	C	T	H	h	lbs	lbs	lbs	lbs	(lbs/FT)	
RC160	160	2.000	1.250	1.125	0.563	2.504	2.685	2.744	1.256	1.437	2.303	0.252	1.882	1.630	49892	55000	60500	11880	6.58	
RC160-2	160-2					4.811	4.992	5.051							99783	110000	121000	20196	13.01	
RC160-3	160-3					7.118	7.299	7.358							149675	165000	181500	29700	19.45	
RC160-4	160-4					9.421	9.598	9.661							199566	220000	242000	39204	25.88	
RC160-5	160-5					11.724	11.945	11.965							249458	275000	302500	46332	32.32	

Max. Horsepower Ratings

Type of Lubrication No. of Teeth of Small Sprocket	Revolutions per minute-Small Sprocket (rpm) (Please refer to P.76 for more details regarding type of lubrication A, B and C.)																							
	A					B					C													
	10	25	50	100	150	200	250	300	350	400	450	500	550	600	650	700	750	800	850	900	1000	1100	1200	1300
11	4.56	10.4	19.4	36.2	52.1	67.6	82.6	97.3	112	126	113	96.5	83.6	73.5	65.1	58.3	52.5	47.7	43.6	39.9	34.2	29.6	26.0	23.1
12	5.00	11.4	21.3	39.8	57.2	74.3	90.8	107	123	138	129	110	95.4	83.6	74.3	66.5	59.9	54.4	49.6	45.6	38.9	33.8	29.6	26.3
13	5.46	12.5	23.2	43.3	62.5	81.0	98.9	116	134	151	145	124	108	94.4	83.6	74.9	67.6	61.3	56.0	51.3	43.8	38.1	33.4	29.6
14	5.91	13.5	25.2	46.9	67.7	87.7	107	126	145	164	162	138	120	105	93.6	83.6	75.5	68.5	62.6	57.4	49.1	42.5	37.3	33.1
15	6.37	15.5	27.1	50.5	72.9	94.4	115	135	157	176	180	154	133	117	104	92.9	83.6	76.0	69.4	63.7	54.4	47.2	41.4	19.7
16	6.82	15.5	29.1	54.3	78.2	101	124	146	168	189	198	169	147	129	114	102	92.2	83.6	76.4	70.1	59.9	51.9	45.6	
17	7.29	16.6	31.1	57.9	83.4	108	132	155	178	201	217	185	161	141	125	112	101	91.7	83.6	76.8	65.5	56.8	49.9	
18	7.76	17.7	33.0	61.7	88.7	115	141	166	190	214	237	202	176	154	137	122	110	99.9	91.2	83.6	71.4	61.9	54.4	
19	8.22	18.8	35.0	65.3	94.1	122	149	176	201	228	253	220	190	166	147	132	119	108	98.9	90.8	77.5	67.2	59.0	
20	8.69	19.8	37.0	69.0	99.5	129	157	185	213	240	267	237	205	180	160	143	129	117	107	98.0	83.6	72.5	63.7	
21	9.16	20.9	39.0	72.8	105	135	166	196	225	253	282	255	221	194	172	155	138	126	115	105	90.1	78.0	34.7	
22	9.64	22.0	41.0	76.5	110	143	174	205	236	267	296	273	237	208	184	165	149	135	123	113	96.5	83.6		
23	10.1	23.1	43.0	80.3	116	150	184	216	248	280	311	292	253	223	197	176	160	145	132	121	103	89.5		
24	10.6	24.1	45.0	84.0	121	157	192	227	260	292	326	311	269	237	210	188	169	154	141	129	110	95.4		
25	11.1	25.2	47.1	87.8	127	164	200	236	271	306	340	331	287	252	224	200	180	164	149	137	117	101		
28	12.5	28.6	53.2	99.3	143	185	227	267	307	346	385	393	340	299	264	237	213	194	177	162				
30	13.5	30.7	57.4	107	154	200	244	288	330	373	414	434	377	331	294	263	237	214	196	180				
32	14.5	33.0	61.5	115	165	214	261	308	354	399	444	479	416	365	323	290	261	237	216					
35	16.0	36.3	67.7	126	182	236	290	339	390	440	489	538	476	417	370	331	299							
40	18.4	42.0	78.2	146	210	272	332	393	450	508	564	621	580	509	452									
45	20.9	47.6	88.9	166	239	310	378	445	512	578	642	705	693	607										
50	23.3	53.4	99.5	186	268	347	424	499	574	646	718	791	811											
55	25.9	59.1	110	206	296	385	469	554	635	717	796	877												
60	28.4	64.9	121	227	326	422	516	607	698	787	875													

Note: 1. Value in above table is for single strand chain only.
For multiplex chain, please apply the coefficient of Multi-strand. Please refer to chain selection on P.64.
2. Please consult with us when the ratings are to the right of the solid blue line.

RC180 Standard Roller Chain

TRANSMISSION
ROLLER CHAIN

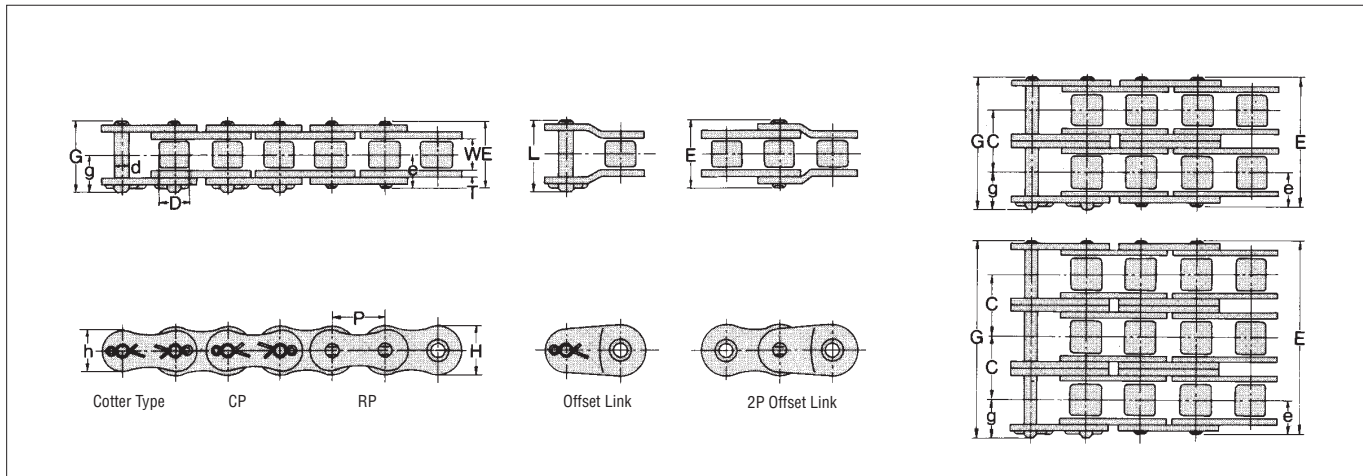

Dimensions

Chain No.	Pitch	Roller Link Width W	Roller Dia. D	Pin						Transverse Pitch C	Plate				JIS Min. Tensile Strength	DID Min. Tensile Strength	DID Avg. Tensile Strength	DID Max. Allowable Load	Approx. Weight (lbs/FT)
				d	E	G	L	e	g		T	H	h						
RC180	180	2.250	1.406	1.406	0.687	2.815	3.043	3.122	1.409	1.638	2.591	0.280	2.118	1.835	69286	74800	81400	13860	8.52
RC180-2	180-2					5.409	5.638	5.717							138572	149600	162800	23562	16.76
RC180-3	180-3					8.004	8.232	8.311							207858	224400	244200	34650	25.01
RC180-4	180-4					10.594	10.823	10.902							277144	299200	325600	45738	33.26
RC180-5	180-5					13.185	13.413	13.492							346430	374000	407000	54054	41.51

Max. Horsepower Ratings

Type of Lubrication No. of Teeth of Small Sprocket	Revolutions per minute-Small Sprocket (rpm) (Please refer to P.76 for more details regarding type of lubrication A, B and C.)																							
	10	25	50	100	150	200	250	300	350	400	450	500	550	600	650	700	750	800	850	900	950	1000	1050	1100
11	6.05	13.8	25.7	48.0	69.2	89.7	110	129	149	149	124	106	92	80.7	71.6	64.1	57.8	52.4	47.9	44.0	40.5	37.5	34.9	32.6
12	6.65	15.1	28.3	52.8	76.0	98.5	120	142	164	169	142	121	105	92.0	81.6	73.1	65.8	59.8	54.6	50.1	46.1	42.8	39.7	37.0
13	7.24	16.5	30.8	57.5	82.8	107	131	154	178	190	160	137	118	104	92.0	82.3	74.3	67.4	61.5	56.4	52.0	48.3	44.8	20.1
14	7.84	18.0	33.4	62.3	89.8	116	142	168	193	213	178	153	132	116	103	92.0	83.0	75.3	68.8	63.1	58.2	53.9	50.1	
15	8.46	19.3	35.9	67.2	96.8	125	153	181	208	233	198	169	146	129	114	102	92.0	83.5	76.3	70.0	64.5	59.8	55.5	
16	9.06	20.6	38.6	72.0	104	134	165	193	223	251	218	186	161	142	126	112	101	92.0	84.0	77.1	71.0	65.8	51.3	
17	9.68	22.1	41.2	76.8	111	143	176	206	237	268	239	204	177	155	138	123	111	101	92.0	84.5	77.9	72.1	13.0	
18	10.3	23.5	43.8	81.8	118	153	186	220	252	284	260	223	193	169	150	134	121	110	100	92.0	84.9	78.6		
19	10.9	24.9	46.5	86.7	125	162	197	233	268	302	282	241	209	184	162	145	131	119	109	99.7	92.0	85.1		
20	11.5	26.3	49.1	91.6	132	172	209	247	283	319	304	260	225	198	176	157	142	129	117	108	99.3	51.5		
21	12.2	27.7	51.7	96.5	139	180	220	260	298	336	328	280	243	213	189	169	153	138	126	116	107			
22	12.8	29.2	54.4	102	146	189	232	273	314	354	351	300	260	228	202	181	164	149	135	124	115			
23	13.4	30.6	57.1	107	153	198	243	287	328	371	375	320	277	244	216	193	174	158	145	133				
24	14.1	32.0	59.8	112	161	208	255	300	345	389	401	342	296	260	231	206	186	169	154					
25	14.7	33.5	62.5	117	168	217	265	314	361	406	426	363	315	276	245	220	198	180						
28	16.6	37.8	70.6	132	190	245	300	354	408	458	505	430	374	328	291	260								
30	17.8	40.8	76.1	142	205	265	324	382	438	495	550	479	414	363	323									
32	19.2	43.7	81.5	153	220	284	347	409	471	529	590	527	456	401	355									
35	21.2	48.1	89.8	168	241	312	382	450	517	584	649	602	521											
40	24.4	55.6	104	193	279	362	442	520	598	674	749	736												
45	27.7	63.1	118	220	316	410	501	591	680	765	851													
50	31.1	70.8	132	247	355	460	562	662	761	858														
55	34.5	78.4	146	273	394	509	623	735	843															
60	37.8	86.2	161	300	432	560	685	807																

Note: 1. Value in above table is for single strand chain only.
 For multiplex chain, please apply the coefficient of Multi-strand. Please refer to chain selection on P.64.
 2. Please consult with us when the ratings are to the right of the solid blue line.

RC200 Standard Roller Chain

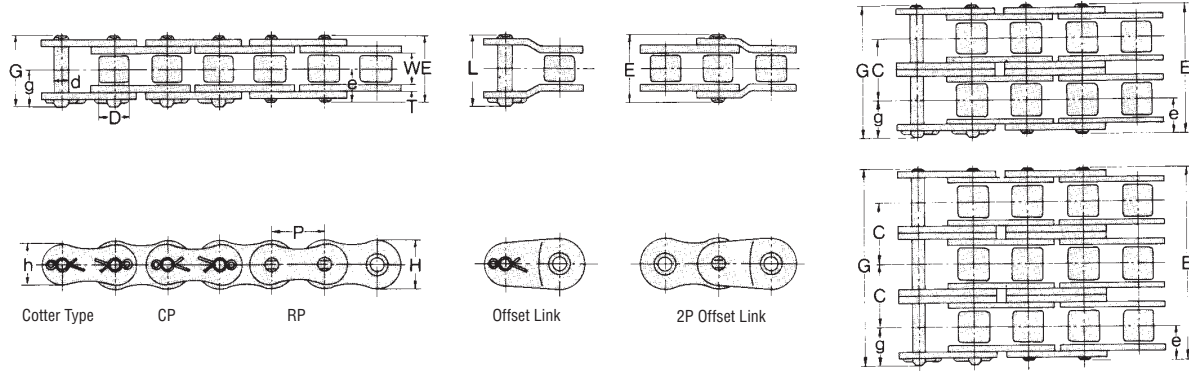

Dimensions

Unit (inch)

Chain No.	Pitch	Roller Link Width	Roller Dia.	Pin							Transverse Pitch	Plate			JIS Min. Tensile Strength	DID Min. Tensile Strength	DID Avg. Tensile Strength	DID Max. Allowable Load	Approx. Weight (lbs/FT)
				D	d	E	G	L	e	g		C	T	H					
RC200	200	1.500	1.562	0.781	3.067	3.346	3.437	1.535	1.811	2.819	0.315	2.362	2.047	77845	96800	105600	16500	11.06	
RC200-2	200-2				5.890	6.165	6.260							155690	193600	211200	28050	21.79	
RC200-3	200-3				8.713	8.988	9.079							233534	290400	316800	41250	32.52	
RC200-4	200-4				11.531	11.807	11.898							311379	387200	422400	54450	43.25	
RC200-5	200-5				14.350	14.626	14.717							389224	484000	528000	64350	53.98	

Max. Horsepower Ratings

Unit (hp)

Type of Lubrication No. of Teeth of Small Sprocket	Revolutions per minute-Small Sprocket (rpm) (Please refer to P.76 for more details regarding type of lubrication A, B and C.)																							
	10	15	20	30	40	50	60	80	100	150	200	250	300	350	400	450	550	600	650	700	750	800	850	900
	A					B										C								
11	7.86	11.30	14.60	21.20	27.30	33.50	39.40	51.10	62.50	89.90	116	142	168	193	161	135	100	87.80	77.90	69.70	62.90	57.10	52.10	47.90
12	8.63	12.40	16.10	23.20	30.00	36.70	43.30	56.20	68.60	98.80	128	157	185	212	184	154	114	100	88.70	79.40	71.60	65.00	59.40	54.40
13	9.41	13.50	17.60	25.30	32.80	40.10	47.20	61.10	74.80	108	139	170	201	231	208	174	129	113	100	89.50	80.70	73.30	66.90	61.40
14	10.20	14.70	19.00	27.50	35.50	43.40	51.20	66.20	81.00	117	151	185	217	251	232	194	143	126	112	100	90.20	81.90	74.80	40.50
15	11.00	15.80	20.50	29.50	38.20	46.80	55.10	71.40	87.30	126	164	200	235	269	257	216	160	139	124	111	100	90.90	83.00	2.12
16	11.80	17.00	22.00	31.60	41.00	50.10	59.10	76.50	93.60	135	174	213	252	290	283	237	176	154	137	122	110	100	91.40	
17	12.60	18.10	23.50	33.80	43.80	53.50	63.10	81.80	99.90	143	186	228	268	308	310	260	192	169	150	134	121	110	100	
18	13.40	19.30	24.90	35.90	46.60	57.00	67.20	87.00	106	153	198	243	286	328	338	283	209	184	164	146	132	119	71.2	
19	14.20	20.40	26.50	38.10	49.50	60.30	71.20	92.20	113	162	210	257	303	349	366	307	227	200	177	158	142	129		
20	15.00	21.60	28.00	40.30	52.10	63.80	75.20	97.50	119	172	223	272	320	367	395	331	245	216	190	170	154			
21	15.80	22.80	29.50	42.50	55.10	67.30	79.20	103	125	181	235	287	338	387	425	357	264	232	205	184				
22	16.60	24.00	31.00	44.60	57.90	70.80	83.40	108	132	190	247	302	355	408	456	382	283	248	220	197				
23	17.40	25.10	32.60	46.90	60.70	74.30	87.40	113	138	200	259	316	373	428	483	409	303	265	236					
24	18.20	26.30	34.00	49.10	63.50	77.70	91.60	119	145	209	271	331	390	448	505	436	323	283	251					
25	19.00	27.50	35.70	51.30	66.50	81.20	95.70	124	151	218	283	346	408	468	528	464	343	300						
28	21.60	31.10	40.20	57.90	75.10	91.80	108	141	172	247	319	390	460	529	597	550	406							
30	23.20	33.50	43.30	62.50	80.80	98.90	116	151	185	265	345	421	496	570	642	609								
32	24.90	35.90	46.50	66.90	86.70	106	125	162	198	286	369	452	532	611	689	670								
35	27.50	39.50	51.20	77.70	95.60	117	138	185	221	314	406	497	586	673	759									
40	31.60	45.70	59.10	87.90	110	135	160	206	252	363	469	574	677	777										
45	36.10	51.90	67.20	96.80	125	153	181	233	286	412	534	653	768											
50	40.30	58.00	75.20	108	141	172	202	263	320	461	598	731	861											
55	44.80	64.30	83.40	120	155	190	224	291	355	512	662	810												
60	49.10	70.80	91.70	132	172	209	247	319	390	562	728	890												

Note: 1. Value in above table is for single strand chain only.
 For multiplex chain, please apply the coefficient of Multi-strand. Please refer to chain selection on P.64.
 2. Please consult with us when the ratings are to the right of the solid blue line.

RC240 Standard Roller Chain

TRANSMISSION
ROLLER CHAIN

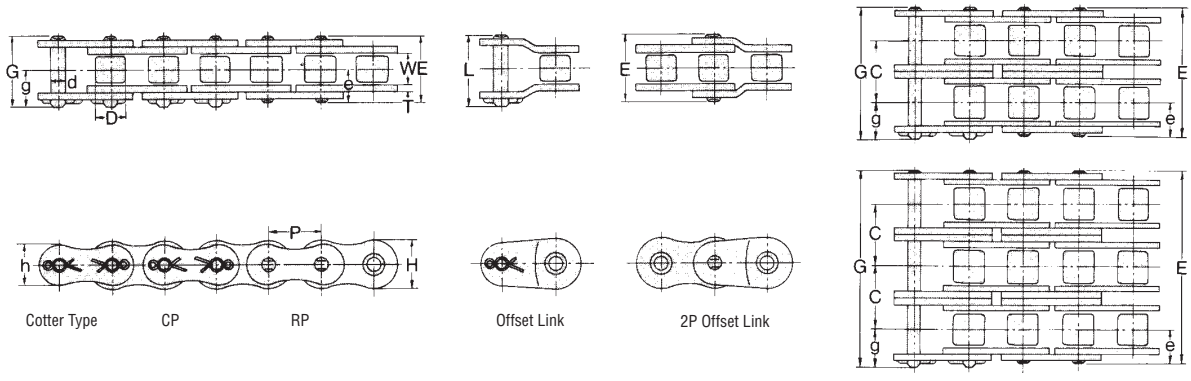

Dimensions

Chain No.	Pitch	Roller Link Width W	Roller Dia. D	Pin							Transverse Pitch C	Plate			JIS Min. Tensile Strength lbs	DID Min. Tensile Strength lbs	DID Avg. Tensile Strength lbs	DID Max. Allowable Load lbs	Approx. Weight (lbs/FT)
				d	E	G	L	e	g	T		H	h						
RC240	240	3.000	1.875	1.875	0.937	3.748	4.051	4.150	1.878	2.177	3.457	0.374	2.815	2.441	112259	139700	154000	22220	15.62
RC240-2	240-2					7.209	7.512	7.610							224519	279400	308000	37774	30.85
RC240-3	240-3					10.665	10.969	11.067							336778	419100	462000	55550	46.07
RC240-4	240-4					14.122	14.425	14.524							449038	558800	616000	73326	61.22
RC240-5	240-5					17.579	17.882	17.980							561297	698500	770000	86658	76.44

Max. Horsepower Ratings

Type of Lubrication No. of Teeth of Small Sprocket	Revolutions per minute-Small Sprocket (rpm) (Please refer to P.76 for more details regarding type of lubrication A, B and C.)																																		
	5							10							15							20							25						
	A							B							C																				
11	6.78	12.70	18.20	23.60	28.80	34.00	44.10	53.90	63.50	82.30	101	123	145	166	188	229	271	228	186	157	134	116	102	90.10											
12	7.45	13.90	20.00	26.00	31.80	37.40	48.40	59.20	69.70	90.30	110	135	160	182	206	252	298	260	213	178	153	132	116	59.50											
13	8.12	15.10	21.80	28.30	34.60	40.80	52.80	64.60	76.00	98.50	121	147	173	200	225	275	324	294	240	201	172	149	131	21.00											
14	8.81	16.50	23.70	30.70	37.50	44.10	57.20	70.00	82.40	107	130	160	188	216	244	298	351	327	268	225	192	166	146												
15	9.48	17.70	25.50	33.00	40.30	47.60	61.70	75.30	88.70	115	141	172	202	233	263	320	378	363	298	249	213	185	162												
16	10.20	19.00	27.30	35.40	43.30	51.10	66.10	80.80	95.20	123	150	185	217	249	282	343	405	399	327	275	235	204	174												
17	10.90	20.20	29.20	37.80	46.20	54.40	70.50	86.20	102	132	161	197	232	267	300	367	433	438	359	300	256	223	135												
18	11.50	21.60	31.10	40.20	49.20	57.90	75.10	91.70	108	141	172	209	247	283	319	390	460	477	391	327	280	243	97.30												
19	12.20	22.80	33.00	42.60	52.10	61.40	79.50	97.20	115	149	181	221	261	300	339	414	488	517	424	355	303	263	59.00												
20	12.90	24.10	34.90	45.00	55.10	64.90	84.00	103	121	157	192	235	276	318	358	437	516	559	457	383	327	284	20.50												
21	13.70	25.50	36.70	47.50	58.00	68.40	88.50	108	128	165	202	247	291	335	377	461	543	602	492	413	353	273													
22	14.30	26.80	38.60	50.00	61.00	72.00	93.20	114	134	174	213	260	306	351	397	485	571	645	528	442	378	236													
23	15.00	28.20	40.50	52.40	64.10	75.50	97.70	120	141	182	223	272	322	369	417	509	599	689	564	473	403	197													
24	15.80	29.40	42.40	54.80	67.00	79.10	102	125	147	192	233	286	336	386	436	532	627	721	602	504	430														
25	16.50	30.70	44.20	57.40	70.10	82.60	107	131	154	200	244	299	351	403	456	556	655	753	639	536	440														
28	18.60	34.70	50.00	64.70	79.20	93.30	121	147	174	225	276	338	397	457	515	629	741	851	757	635															
30	20.10	37.40	53.90	69.80	85.40	101	130	160	188	243	298	363	428	492	555	678	799	918	840																
32	21.40	40.10	57.80	74.80	91.60	108	139	170	201	261	319	390	458	527	595	727	857	984	920																
35	23.70	44.20	63.70	82.40	100	119	154	188	221	287	351	429	505	580	655	800	944	1084																	
40	27.30	51.10	73.60	95.30	116	137	178	217	256	331	405	496	584	672	756	925	1090																		
45	31.10	58.00	83.50	108	132	155	202	247	291	377	461	563	664	761	859	1051																			
50	34.90	65.00	93.60	121	149	174	227	276	326	422	516	631	743	854	962	1177																			
55	38.60	72.00	104	134	165	193	251	307	361	468	572	700	824	946	1067																				
60	42.40	79.10	114	147	181	213	275	336	397	513	629	768	905	1040	1173																				

Note: 1. Value in above table is for single strand chain only.
 For multiplex chain, please apply the coefficient of Multi-strand. Please refer to chain selection on P.64.
 2. Please consult with us when the ratings are to the right of the solid blue line.

ANSI Heavy Type Roller Chain

TRANSMISSION
ROLLER CHAIN

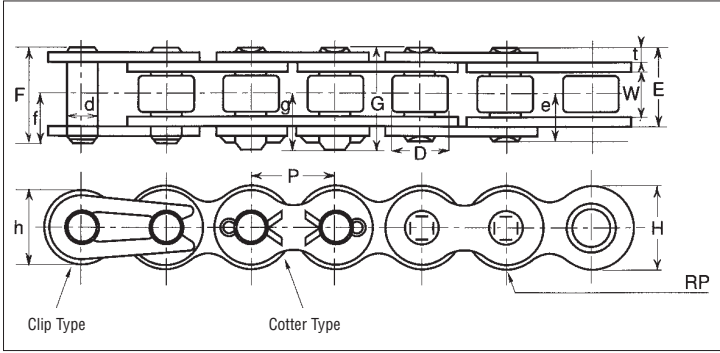

Dimensions

Unit (inch)

Chain No.		Pitch P	Roller Link Width W	Roller Dia. D	Pin						Plate		DID Avg. Tensile Strength lbs	Approx. Weight (lbs/ft)
DID	ANSI				d	E	F	G	f	g	T	H		
RC60H	60H	0.750	0.500	0.469	0.235	1.130	1.191	1.228	0.636	0.667	0.126	0.713	10340	1.3
RC80H	80H	1.000	0.625	0.625	0.313	1.413	1.469	1.524	0.770	0.811	0.157	0.945	18480	2.0
RC100H	100H	1.250	0.750	0.750	0.376	1.685	—	1.803	—	0.961	0.189	1.177	27500	2.8
RC120H	120H	1.500	1.000	0.875	0.437	2.094	—	2.224	—	1.177	0.220	1.413	38500	4.1
RC140H	140H	1.750	1.000	1.000	0.500	2.240	—	2.429	—	1.311	0.252	1.650	53900	5.9
RC160H	160H	2.000	1.250	1.007	0.563	2.638	—	2.819	—	1.504	0.280	1.882	68200	7.3
RC200H	200H	2.500	1.500	1.563	0.781	3.335	—	3.610	—	1.945	0.374	2.362	116600	12.9
RC240H	240H	3.000	1.875	1.875	0.937	4.276	—	4.579	—	2.429	0.500	2.815	180400	19.0

A Type Double Pitch Roller Chain

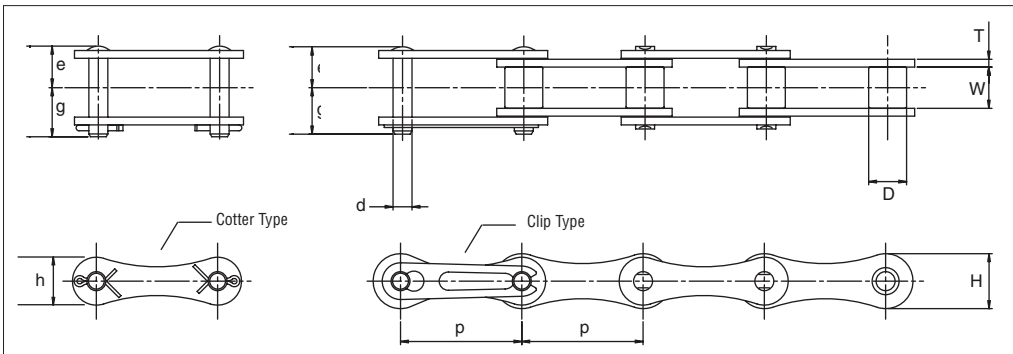

Dimensions

Unit (inch)

Chain No.		Pitch P	Roller Link Width W	Roller Dia. D	Pin			Plate			DID Avg. Tensile Strength lbs	DID Max Allowable Load lbs	Approx. Weight (lbs/ft)
DID	ANSI				d	E	G	T	H	h			
RA2040	A2040	1.000	0.313	0.312	0.156	0.325	0.398	0.059	0.461	0.394	3828	594	0.27
RA2050	A2050	1.250	0.375	0.400	0.200	0.400	0.472	0.079	0.559	0.512	6446	990	0.44
RA2060	A2060	1.500	0.500	0.469	0.235	0.500	0.594	0.094	0.677	0.598	9020	1452	0.64
RA2080	A2080	2.000	0.625	0.625	0.313	0.646	0.748	0.126	0.917	0.748	15400	2530	1.16
RA2100	A2100	2.500	0.750	0.750	0.376	0.791	0.898	0.157	1.134	0.965	25300	4180	1.72
RA2120	A2120	3.000	1.000	0.875	0.437	0.996	1.110	0.189	1.331	1.142	35200	5720	2.47

2-2 **D.I.D.** Ultimate Power Series Roller Chain

Features

All D.I.D Ultimate Power Series Roller Chains feature through hardened and quad staked pins and superior materials on other components. Multiple strand chains have semi press fit center plates and bushed center plates for connecting links to increase the fatigue strength and shock load capacity.

2-2-1 **D.I.D.** HI*PWR K Series Roller Chain

Features

D.I.D K Series roller chain is designed to obtain higher tensile strength and shock load capacity with the same physical dimensions as ANSI standard roller chain. K Series roller chain is recommended for slow to moderate speed drive and heavy load conditions, such as oilfield applications.

ULTIMATE POWER SERIES

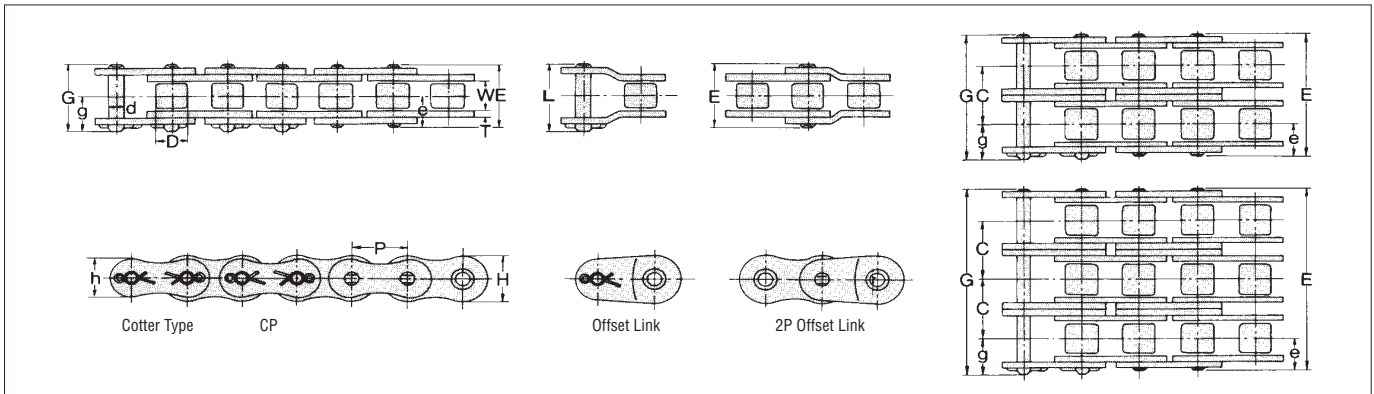

Max. Horsepower Ratings

Unit (inch)

Chain No. DID	ANSI	Pitch P	Roller Link Width W	Roller (Bush) Dia. D	Pin						Transverse Pitch C	Plate			DID Avg. Tensile Strength lbs	DID Max. Allowable Load lbs	Approx. Weight (lbs/FT)
					d	E	G	L	e	g		T	H	h			
RC80K	80	1	0.625	0.625	0.313	1.283	1.394	1.461	0.646	0.748	1.154	0.126	0.945	0.819	17,820	3,520	1.8
RC80K-2	80-2					2.437	2.547	2.610							35,640	5,984	3.5
RC80K-3	80-3					3.594	3.701	3.744							53,460	8,800	5.3
RC80K-4	80-4					4.748	4.854	4.898							80,080	11,616	7.0
RC100K	100	1.25	0.750	0.750	0.376	1.555	1.673	1.780	0.780	0.894	1.409	0.157	1.177	1.024	27,280	5,500	2.7
RC100K-2	100-2					2.965	3.083	3.193							54,560	9,350	5.3
RC100K-3	100-3					4.378	4.496	4.535							81,840	13,750	7.9
RC100K-4	100-4					5.787	5.906	5.945							109,120	18,150	10.4
RC120K	120	1.5	1.000	0.875	0.437	1.957	2.087	2.209	0.980	1.110	1.787	0.189	1.413	1.228	39,600	7,480	3.9
RC120K-2	120-2					3.748	3.878	3.921							79,200	12,716	7.7
RC120K-3	120-3					5.535	5.665	5.709							118,800	18,700	11.5
RC120K-4	120-4					7.327	7.457	7.500							158,400	24,684	15.3
RC140K	140	1.75	1.000	1.000	0.500	2.110	2.299	2.346	1.055	1.248	1.925	0.220	1.650	1.429	52,800	9,900	5.1
RC140K-2	140-2					4.039	4.228	4.276							105,600	16,830	10.1
RC140K-3	140-3					5.965	6.154	6.201							158,400	24,750	15.2
RC140K-4	140-4					7.894	8.083	8.130							211,200	32,670	20.2
RC160K	160	2	1.250	1.125	0.563	2.504	2.685	2.744	1.256	1.437	2.303	0.252	1.882	1.630	68,200	12,760	6.8
RC160K-2	160-2					4.811	4.992	5.051							136,400	21,692	13.1
RC160K-3	160-3					7.118	7.299	7.358							204,600	31,900	19.4
RC160K-4	160-4					9.421	9.598	9.661							272,800	42,108	25.5
RC180K	180	2.25	1.406	1.406	0.687	2.815	3.043	3.122	1.409	1.638	2.591	0.280	2.118	1.835	88,000	15,180	9.1
RC180K-2	180-2					5.409	5.638	5.717							176,000	25,806	17.3
RC180K-3	180-3					8.004	8.232	8.311							264,000	37,950	25.5
RC180K-4	180-4					10.594	10.823	10.902							352,000	50,094	33.8
RC200K	200	2.5	1.500	1.562	0.781	3.067	3.346	3.437	1.535	1.811	2.819	0.315	2.362	2.047	106,700	17,160	11.3
RC200K-2	200-2					5.890	6.165	6.260							213,400	29,172	21.1
RC200K-3	200-3					8.713	8.988	9.079							320,100	42,900	31.0
RC200K-4	200-4					11.531	11.807	11.898							426,800	56,628	40.8
RC240K	240	3	1.875	1.875	0.937	3.748	4.051	4.150	1.878	2.177	3.457	0.374	2.815	2.441	155,100	22,880	16.3
RC240K-2	240-2					7.209	7.512	7.610							310,200	38,896	29.8
RC240K-3	240-3					10.665	10.969	11.067							465,300	57,200	43.3
RC240K-4	240-4					14.122	14.425	14.524							620,400	75,306	56.9

Note: Value in above table is for single strand chain only. For multiplex chain, please apply the coefficient of Multi-strand. Please refer to chain selection on p.64

2-2-2 **DID** HI*PWR KS Series Roller Chain



Features

KS type roller chain are enhanced in fatigue strength and shock strength without changing the dimension in the pin length direction of standard roller chains. Plates are enlarged, and the machining accuracy and assembling accuracy of components are improved. The roller chains hold high transmission efficiency for applications from low to high speeds and are powerful enough to withstand long-term use.



ULTIMATE POWER SERIES

Maximum Horsepower rating diagram

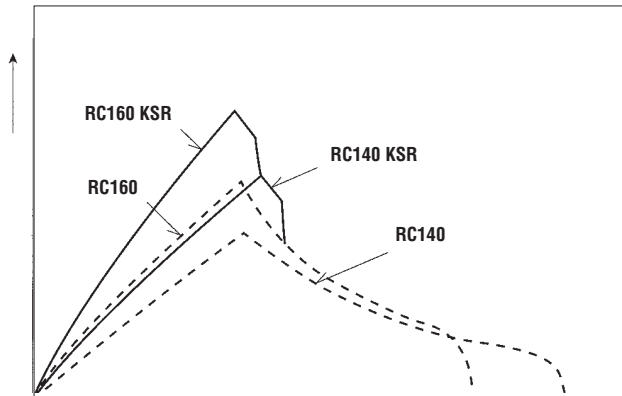

Cautions for use

1. As connecting links, use semi-press fit type connecting links for KS Series. In a semi-press fit type connecting link, the pins are lightly interference-fitted with the connecting plate. For the connection between the connecting plate and the connecting pins, roll pins are used instead of the cotter pins. Never make the holes of the connecting plate larger and never make the pins thinner to facilitate the work for fitting the pins into the connecting plate, since otherwise the fatigue strength will be reduced. The intermediate plates of a semi-press fit type connecting link for multiplex chain has bushings pressed in.
2. KS type roller chain do not have offset links. Use in an even number of links.
3. In general, select your chain with reference to "Designing of roller chain transmission" and also to the tables of maximum horsepower ratings and dimensions of KS type roller chains (P.30 - 38).
4. The available number of strands is up to triple strands.

Applications

Compared to standard roller chain, KS type roller chain are higher in maximum horsepower rating by about 30 percent in a medium to low speed range. They perform excellent in places where large shock loads apply, frequent start/stop drives, and also in relatively high speed applications.

<Applications> Civil engineering machines such as power shovels, trenchers, trucks, cranes and truck mixers agitators, and shock-applied drives for conveyors, elevators, stackers, etc.

Dimensions

Chain No.	Pitch	Roller Link Width	Roller Dia.	Pin					Transverse Pitch	Plate			JIS	DID	DID	DID	Approx. Weight (lbs/ft)	
				d	E	G	L	g		C	T	H	h	Min. Tensile Strength	Min. Tensile Strength	Avg. Tensile Strength		Max. Allowable Load
DID	ANSI	P	W	D														
RC80KSR	80	1.000	0.625	0.625	0.313	1.283	1.394	0.646	0.748	1.154	0.126	0.949	0.819	12474	16940	18920	4180	1.89
RC100KSR	100	1.250	0.750	0.750	0.376	1.555	1.673	0.780	0.894	1.409	0.157	1.185	1.024	19450	26180	28600	6820	2.80
RC120KSR	120	1.500	1.000	0.875	0.437	1.957	2.087	0.980	1.110	1.787	0.189	1.425	1.228	27953	38500	41800	9020	4.10
RC140KSR	140	1.750	1.000	1.000	0.500	2.110	2.299	1.055	1.248	1.925	0.220	1.661	1.429	37913	50600	55000	12100	5.17
RC160KSR	160	2.000	1.250	1.125	0.563	2.504	2.685	1.256	1.437	2.303	0.252	1.898	1.630	49892	64680	70400	15840	7.04
RC180KSR	180	2.250	1.406	1.406	0.687	2.815	3.043	1.409	1.638	2.591	0.280	2.134	1.835		84920	92400	18700	9.66
RC200KSR	200	2.500	1.500	1.562	0.781	3.067	3.346	1.535	1.811	2.819	0.315	2.370	2.047	77845	103180	112200	22000	11.73
RC240KSR	240	3.000	1.875	1.875	0.937	3.748	4.051	1.878	2.177	3.457	0.374	2.843	2.441	114459	149600	162800	29700	16.56

Note: Value in above table is for single strand chain only. For multiplex chain, please apply the coefficient of Multi-strand. Please refer to chain selection on p.64

RC80KS

ULTIMATE POWER SERIES

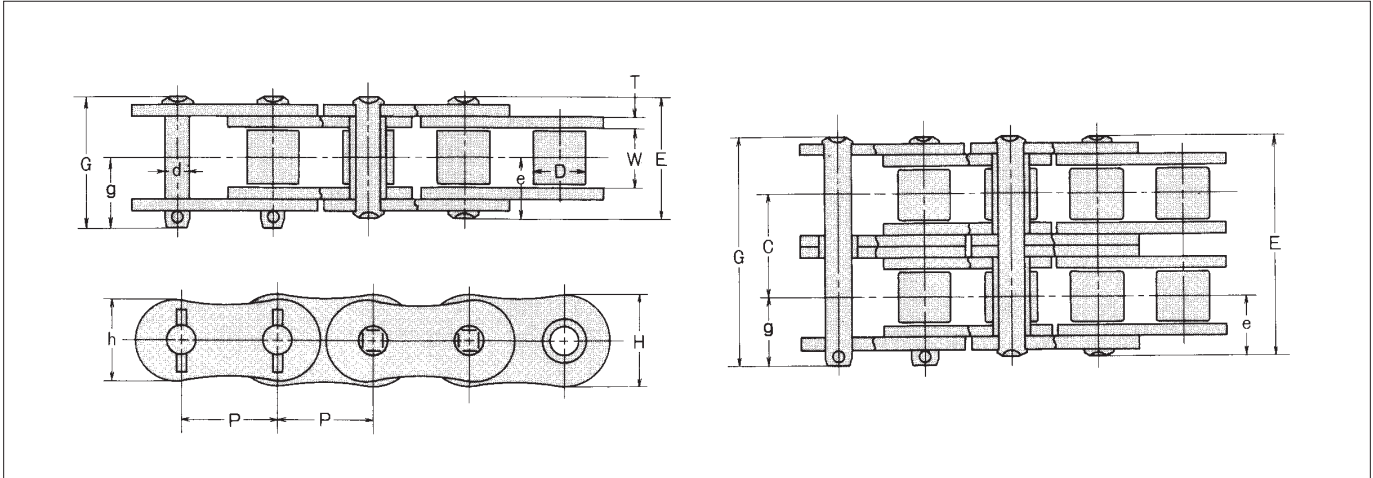

Dimensions

Unit (inch)

Chain No.		Pitch P	Roller Link Width W	Roller (Bush) Dia. D	Pin					Transverse Pitch C	Plate			JIS Min. Tensile Strength lbs	DID Min. Tensile Strength lbs	DID Avg. Tensile Strength lbs	DID Max Allowable Load lbs	Approx. Weight (lbs/ft)
DID	ANSI				d	E	G	e	g		T	H	h					
RC80KS	80	1.000	0.625	0.625	0.313	1.283	1.394	0.646	0.748	1.154	0.126	0.949	0.819	12474	16940	18920	4180	1.89
RC80KS-2R	80-2					2.437	2.547							24948	33880	37840	7106	3.76
RC80KS-3R	80-3					3.594	3.701							37422	50820	56760	10450	5.53

Max. Horsepower Ratings

Unit (hp)

No. of Teeth of Small Sprocket	Revolutions per minute-Small Sprocket (rpm) (Please refer to P.76 for more details regarding type of lubrication A, B and C.)									
	25	50	100	200	300	400	500	700	900	1000
	A			B				C		
11	1.97	3.69	6.88	12.80	18.50	24.00	29.20	39.70	32.20	
12	2.17	4.05	7.55	14.10	20.20	26.30	32.20	43.60	36.60	
13	2.36	4.41	8.23	15.40	22.10	28.70	35.10	47.50	41.30	
14	2.56	4.79	8.93	16.60	24.00	31.10	37.90	51.50	46.10	
15	2.76	5.15	9.61	18.00	25.90	33.50	40.90	55.40	51.20	
16	2.96	5.52	10.30	19.30	27.70	35.90	43.80	59.40	56.40	
17	3.16	5.90	11.00	20.50	29.60	38.30	46.80	63.40	61.80	
18	3.36	6.27	11.70	21.80	31.50	40.80	49.90	67.40	67.30	
19	3.57	6.65	12.40	23.20	33.40	43.20	52.80	71.40	73.10	
20	3.77	7.02	13.10	24.50	35.30	45.70	55.80	75.50	78.80	67.30
21	3.97	7.41	13.80	25.70	37.10	48.10	58.80	79.60	84.90	72.40
22	4.17	7.79	14.50	27.10	39.00	50.70	61.90	83.80	90.90	77.60
23	4.38	8.18	15.30	28.40	41.00	53.10	64.90	87.90	97.20	83.00
24	4.58	8.55	16.00	29.80	42.90	55.60	68.00	92.00	104.00	88.50
25	4.79	8.94	16.80	31.10	44.90	58.20	71.00	96.10	110.00	94.10
28	5.42	10.10	18.90	35.30	50.70	65.70	80.30	109.00	131.00	112.00
30	5.83	10.90	20.40	37.90	54.60	70.80	86.50	117.00	145.00	124.00
32	6.26	11.70	21.80	40.60	58.60	75.90	92.80	125.00	157.00	137.00
35	6.89	12.90	24.00	44.80	64.50	83.50	102.00	138.00	173.00	155.00
40	7.96	14.90	27.70	51.70	74.50	96.50	118.00	160.00	200.00	190.00

Note: Value in above table is for single strand chain only. For multiplex chain, please apply the coefficient of Multi-strand. Please refer to chain selection on p.64

RC100KS

ULTIMATE POWER SERIES

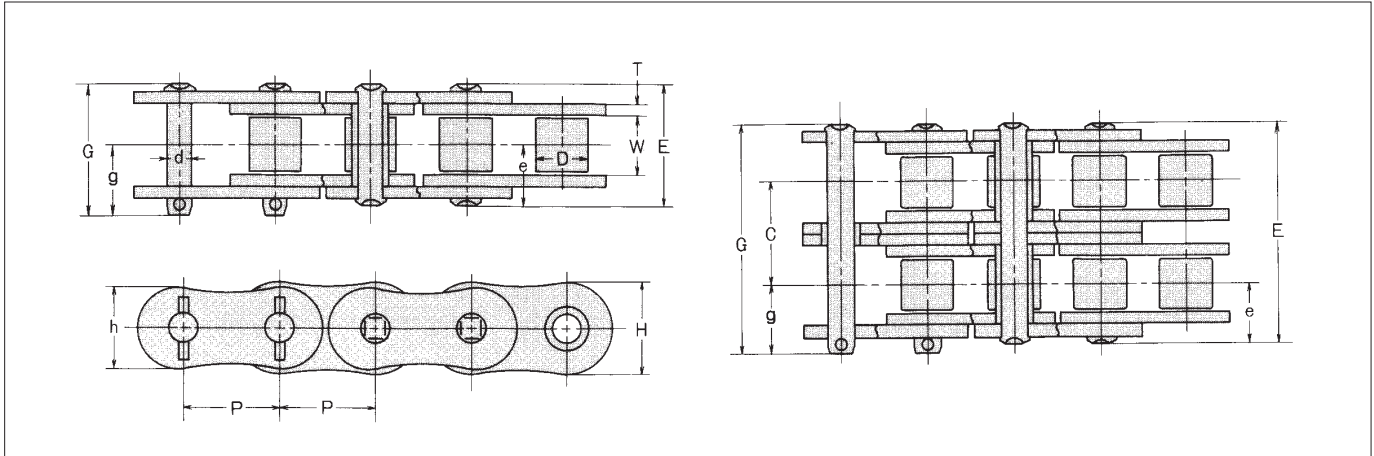

Dimensions

Chain No.		Pitch P	Roller Link Width W	Roller (Bush) Dia. D	Pin					Trans- verse Pitch C	Plate			JIS Min. Tensile Strength lbs	DID Min. Tensile Strength lbs	DID Avg. Tensile Strength lbs	DID Max Allowable Load lbs	Approx. Weight (lbs/ft)
DID	ANSI				d	E	G	e	g		T	H	h					
RC100KS-R	100	1.250	0.750	0.750	0.376	1.555	1.673	0.780	0.894	1.409	0.157	1.185	1.024	19450	26180	28600	6820	2.80
RC100KS-2R	100-2					2.965	3.083							38900	52360	57200	11594	5.51
RC100KS-3R	100-3					4.378	4.496							58351	78540	85800	17050	8.18

Max. Horsepower Ratings

No. of Teeth of Small Sprocket	Revolutions per minute-Small Sprocket (rpm) (Please refer to P.76 for more details regarding type of lubrication A, B and C.)											
	Type of Lubrication											
	10	25	50	100	200	300	400	500	600	700	800	900
	A			B			C					
11	1.41	3.22	5.99	11.20	20.90	30.00	39.00	47.60	56.00	56.00		
12	1.54	3.53	6.58	12.30	22.90	33.00	42.80	52.30	61.70	63.80		
13	1.69	3.85	7.17	13.40	25.10	36.10	46.60	57.00	67.20	72.00		
14	1.82	4.17	7.77	14.50	27.10	39.00	50.50	61.80	72.80	80.40		
15	1.97	4.49	8.38	15.70	29.20	42.00	54.40	66.50	78.40	89.30	73.10	
16	2.10	4.81	8.98	16.80	31.20	45.00	58.30	71.30	84.00	96.60	80.40	
17	2.25	5.13	9.58	18.00	33.40	48.10	62.30	76.10	89.80	103.00	88.10	
18	2.40	5.47	10.20	19.00	35.50	51.20	66.40	81.00	95.40	110.00	96.00	
19	2.55	5.79	10.80	20.20	37.70	54.30	70.20	85.90	101.00	116.00	104.00	
20	2.68	6.13	11.40	21.30	39.80	57.40	74.30	90.80	107.00	123.00	112.00	
21	2.83	6.46	12.10	22.50	42.00	60.50	78.30	95.70	113.00	129.00	121.00	
22	2.98	6.78	12.70	23.60	44.10	63.50	82.30	101.00	119.00	137.00	130.00	
23	3.12	7.12	13.30	24.80	46.20	66.60	86.30	106.00	124.00	143.00	138.00	
24	3.27	7.45	13.90	26.00	48.50	69.80	90.50	111.00	130.00	150.00	147.00	
25	3.42	7.79	14.60	27.20	50.70	72.90	94.50	116.00	137.00	157.00	157.00	
28	3.86	8.81	16.50	30.70	57.20	82.40	107.00	131.00	154.00	177.00	186.00	
30	4.16	9.49	17.70	33.10	61.70	88.90	115.00	141.00	166.00	190.00	206.00	
32	4.46	10.20	19.00	35.40	66.10	95.30	123.00	151.00	178.00	204.00	228.00	190.00
35	4.92	11.20	20.90	39.00	72.80	105.00	135.00	166.00	196.00	225.00	253.00	218.00
40	5.67	12.90	24.10	45.00	84.20	121.00	157.00	192.00	227.00	260.00	294.00	267.00

Note: Value in above table is for single strand chain only. For multiplex chain, please apply the coefficient of Multi-strand. Please refer to chain selection on p.64

RC120KS

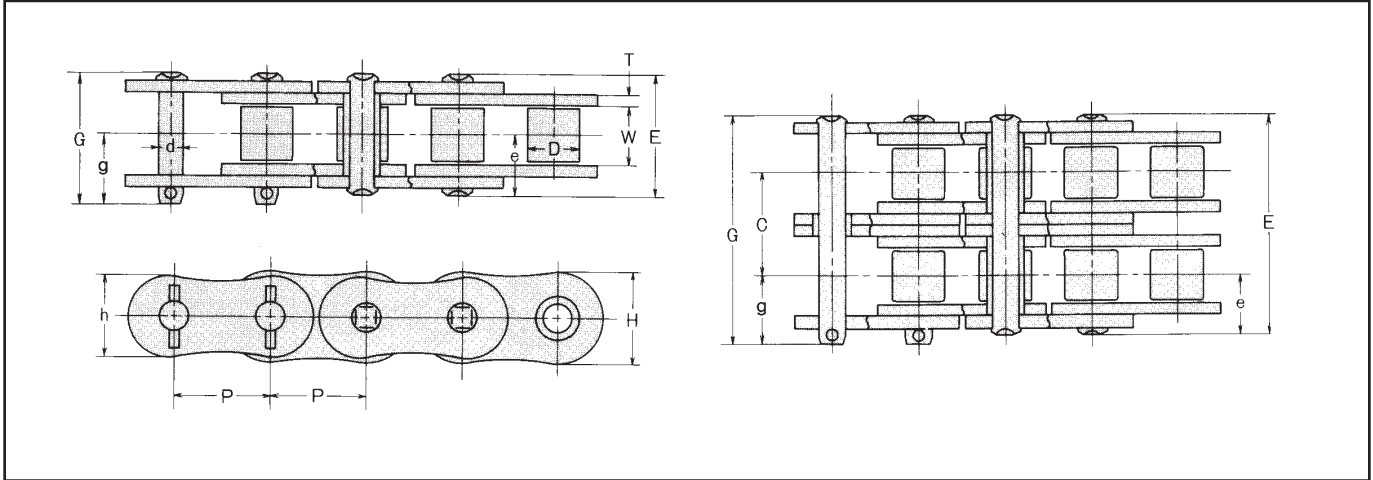

Dimensions

Unit (inch)

Chain No.		Pitch P	Roller Link Width W	Roller (Bush) Dia. D	Pin					Transverse Pitch C	Plate			JIS Min. Tensile Strength lbs	DID Min. Tensile Strength lbs	DID Avg. Tensile Strength lbs	DID Max Allowable Load lbs	Approx. Weight (lbs/ft)
DID	ANSI				d	E	G	e	g		T	H	h					
RC120KS-R	120	1.500	1.000	0.875	0.437	1.957	2.087	0.980	1.110	1.787	0.189	1.425	1.228	27953	36300	41800	9020	4.10
RC120KS-2R	120-2					3.748	3.878							55906	72600	83600	15334	8.18
RC120KS-3R	120-3					5.535	5.665							83860	108900	125400	22550	12.20

Max. Horsepower Ratings

Unit (hp)

Type of Lubrication No. of Teeth of Small Sprocket	Revolutions per minute-Small Sprocket (rpm) (Please refer to P.76 for more details regarding type of lubrication A, B and C.)											
	10	25	50	100	150	200	300	400	500	600	700	800
	A			B			C					
11	2.52	5.75	10.70	20.00	28.80	37.40	53.80	69.70	85.30	81.60		
12	2.76	6.31	11.80	22.00	31.60	41.00	59.10	76.50	93.60	93.00		
13	3.02	6.89	12.80	24.00	34.60	44.80	64.50	83.50	102.00	105.00		
14	3.27	7.45	13.90	26.00	37.40	48.50	69.80	90.50	111.00	117.00		
15	3.53	8.03	15.00	26.80	40.30	52.30	75.20	97.50	119.00	130.00		
16	3.78	8.62	16.10	30.00	43.20	56.00	80.70	104.00	128.00	143.00		
17	4.03	9.20	17.20	32.00	46.10	59.80	86.10	112.00	137.00	157.00	125.00	
18	4.29	9.79	18.20	34.00	49.10	63.50	91.60	119.00	145.00	170.00	135.00	
19	4.54	10.40	19.30	36.10	52.00	67.40	97.10	126.00	154.00	181.00	147.00	
20	4.80	11.00	20.50	38.20	55.00	71.20	103.00	133.00	162.00	192.00	160.00	
21	5.07	11.60	21.60	40.20	57.90	75.10	108.00	141.00	172.00	202.00	172.00	
22	5.32	12.10	22.70	42.40	61.00	79.00	114.00	147.00	180.00	212.00	184.00	
23	5.59	12.70	23.90	44.40	63.90	82.80	119.00	154.00	189.00	223.00	196.00	
24	5.86	13.40	24.90	46.50	66.90	86.70	125.00	162.00	198.00	233.00	209.00	
25	6.11	13.90	26.00	48.50	70.00	90.60	131.00	169.00	206.00	244.00	223.00	
28	6.92	15.80	29.50	55.00	79.10	102.00	147.00	192.00	233.00	275.00	263.00	
30	7.44	17.00	31.60	59.10	85.30	110.00	160.00	206.00	252.00	296.00	292.00	
32	7.99	18.20	34.00	63.40	91.30	118.00	170.00	221.00	269.00	318.00	322.00	
35	8.79	20.10	37.40	69.80	101.00	130.00	188.00	243.00	298.00	350.00	367.00	
40	10.20	23.20	43.30	80.70	116.00	150.00	217.00	282.00	343.00	405.00	315.00	367.00

Note: Value in above table is for single strand chain only. For multiplex chain, please apply the coefficient of Multi-strand. Please refer to chain selection on p.64

RC140KS

ULTIMATE POWER SERIES

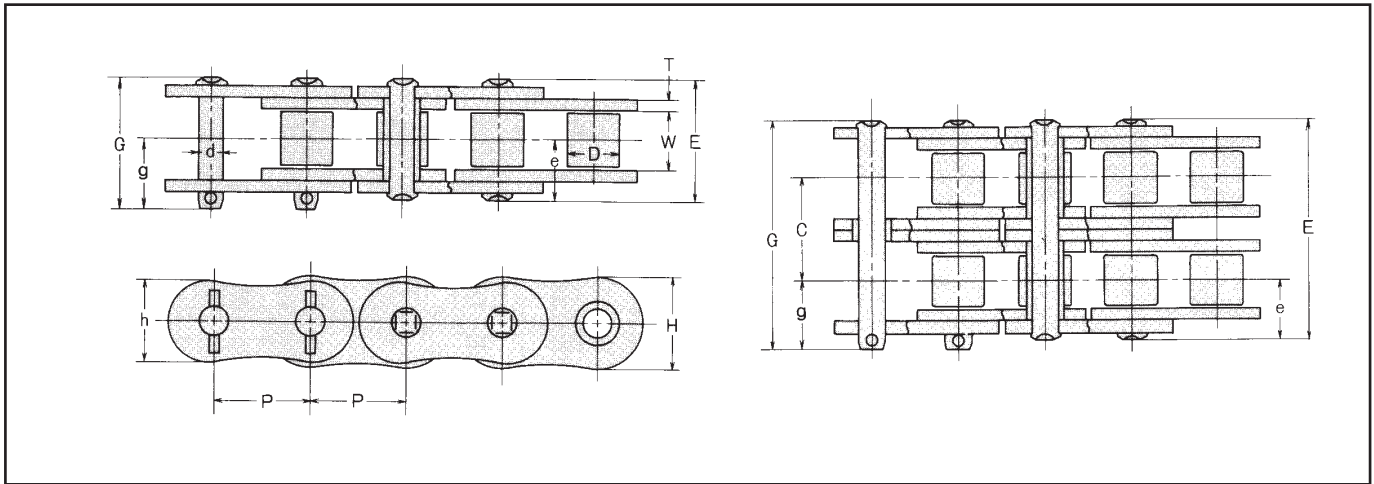

Dimensions

Unit (inch)

Chain No.		Pitch P	Roller Link Width W	Roller (Bush) Dia. D	Pin					Trans- verse Pitch C	Plate				JIS Min. Tensile Strength lbs	DID Min. Tensile Strength lbs	DID Avg. Tensile Strength lbs	DID Max Allowable Load lbs	Approx. Weight (lbs/ft)
DID	ANSI				d	E	G	e	g		T	H	h						
RC140KS	140	1.750	1.000	1.000	0.500	2.110	2.299	1.055	1.248	1.925	0.220	1.661	1.429	37913	48400	55000	12100	5.17	
RC140KS-2R	140-2					4.039	4.228							75825	96800	110000	20570	10.26	
RC140KS-3R	140-3					5.965	6.154							113738	145200	165000	30250	15.36	

Max. Horsepower Ratings

Unit (hp)

Type of Lubrication No. of Teeth of Small Sprocket	Revolutions per minute-Small Sprocket (rpm) (Please refer to P.76 for more details regarding type of lubrication A, B and C.)													
	10	25	50	100	150	200	250	300	350	400	450	500	550	600
	A			B					C					
11	3.87	8.85	16.50	30.80	44.40	57.50	70.20	82.80	95.00	107.00	119.00	121.00	105.00	92.40
12	4.26	9.72	18.10	33.80	48.80	63.10	77.20	90.90	104.00	118.00	131.00	138.00	120.00	105.00
13	4.64	10.60	19.80	36.90	53.10	68.90	84.20	99.20	114.00	128.00	143.00	155.00	135.00	119.00
14	5.03	11.50	21.40	39.90	57.50	74.50	91.20	107.00	123.00	139.00	154.00	170.00	150.00	133.00
15	5.42	12.40	23.10	43.00	62.10	80.30	98.30	116.00	133.00	150.00	166.00	184.00	168.00	147.00
16	5.80	13.30	24.80	46.10	66.50	86.20	105.00	124.00	142.00	161.00	178.00	197.00	185.00	162.00
17	6.21	14.20	26.40	49.30	71.00	92.00	112.00	132.00	153.00	172.00	190.00	209.00	202.00	177.00
18	6.60	15.00	28.20	52.40	75.50	97.90	120.00	141.00	162.00	182.00	202.00	223.00	220.00	193.00
19	7.00	16.00	29.80	55.60	80.00	104.00	127.00	149.00	172.00	193.00	216.00	236.00	239.00	210.00
20	7.40	16.90	31.50	58.70	84.60	110.00	134.00	158.00	181.00	205.00	228.00	251.00	259.00	227.00
21	7.79	17.80	33.20	61.90	89.10	116.00	141.00	166.00	192.00	216.00	240.00	264.00	277.00	244.00
22	8.19	18.80	34.90	65.10	93.80	121.00	149.00	176.00	201.00	227.00	252.00	277.00	298.00	261.00
23	8.61	19.00	36.60	68.40	98.40	127.00	155.00	184.00	210.00	237.00	264.00	291.00	316.00	279.00
24	9.01	20.50	38.30	71.60	103.00	134.00	164.00	192.00	221.00	249.00	277.00	304.00	331.00	298.00
25	9.41	21.40	40.10	74.80	108.00	139.00	170.00	201.00	231.00	260.00	290.00	318.00	347.00	316.00
28	10.60	24.30	45.30	84.50	122.00	158.00	193.00	227.00	261.00	294.00	327.00	359.00	391.00	375.00
30	11.50	26.10	48.80	91.00	131.00	170.00	208.00	244.00	282.00	316.00	353.00	387.00	422.00	417.00
32	12.30	28.00	52.30	97.60	141.00	182.00	223.00	263.00	302.00	339.00	378.00	416.00	453.00	458.00
35	13.50	30.80	57.60	108.00	155.00	201.00	245.00	290.00	332.00	374.00	416.00	457.00	499.00	524.00
40	15.70	35.70	66.50	124.00	178.00	232.00	283.00	334.00	383.00	433.00	481.00	528.00	576.00	

Note: Value in above table is for single strand chain only. For multiplex chain, please apply the coefficient of Multi-strand.
Please refer to chain selection on p.64

RC160KS

ULTIMATE POWER SERIES

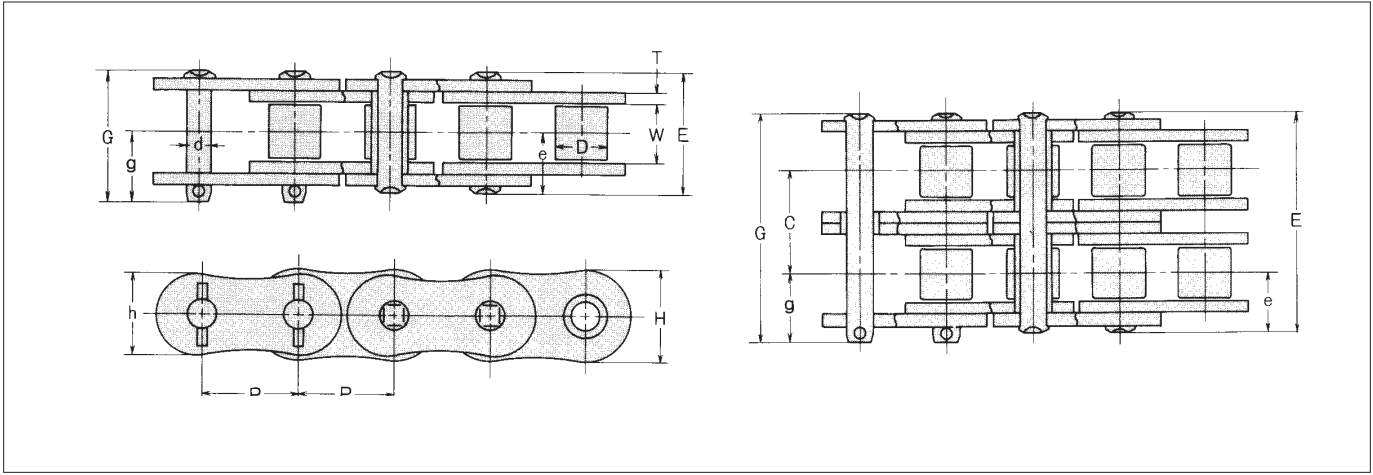

Dimensions

Unit (inch)

Chain No.	Pitch	Roller Link Width	Roller (Bush) Dia.	Pin					Transverse Pitch	Plate			JIS Min. Tensile Strength	DID Min. Tensile Strength	DID Avg. Tensile Strength	DID Max Allowable Load	Approx. Weight (lbs/ft)	
				D	d	E	G	e		g	C	T						H
RC160KS	160	2.000	1.250	1.125	0.563	2.504	2.685	1.256	1.437	2.303	0.252	1.898	1.630	49892	61160	70400	15840	7.04
RC160KS-2R	160-2					4.811	4.992							99783	122320	140800	26928	13.95
RC160KS-3R	160-3					7.118	7.299							149675	183480	211200	39600	20.92

Max. Horsepower Ratings

Unit (hp)

Type of Lubrication No. of Teeth of Small Sprocket	Revolutions per minute-Small Sprocket (rpm) (Please refer to P.76 for more details regarding type of lubrication A, B and C.)												
	10	25	50	100	150	200	250	300	350	400	450	500	550
	A			B					C				
11	5.40	12.30	22.90	42.90	61.80	80.00	97.90	115.00	132.00	149.00	158.00	135.00	
12	5.92	13.50	25.20	47.10	67.80	87.90	108.00	127.00	146.00	164.00	181.00	154.00	
13	6.46	14.70	27.50	51.30	74.00	95.80	117.00	138.00	158.00	178.00	198.00	174.00	
14	7.01	16.00	29.80	55.60	80.20	104.00	127.00	150.00	172.00	194.00	216.00	194.00	
15	7.55	17.20	32.20	59.90	86.30	112.00	137.00	161.00	185.00	209.00	232.00	216.00	
16	8.10	18.50	34.50	64.20	92.60	120.00	146.00	173.00	198.00	224.00	249.00	237.00	
17	8.63	19.70	36.70	68.60	98.80	128.00	157.00	185.00	212.00	239.00	265.00	260.00	
18	9.18	20.90	39.10	73.10	105.00	137.00	166.00	196.00	225.00	255.00	283.00	283.00	
19	9.75	22.30	41.40	77.30	111.00	145.00	177.00	208.00	239.00	269.00	299.00	307.00	265.00
20	10.30	23.50	43.80	81.80	118.00	153.00	186.00	220.00	252.00	284.00	316.00	331.00	287.00
21	10.90	24.80	46.20	86.20	124.00	161.00	197.00	232.00	267.00	300.00	334.00	357.00	310.00
22	11.40	26.00	48.50	90.60	131.00	169.00	206.00	244.00	268.00	315.00	351.00	382.00	331.00
23	12.00	27.30	50.90	95.20	137.00	177.00	217.00	256.00	294.00	331.00	369.00	405.00	354.00
24	12.50	28.60	53.40	99.60	143.00	186.00	227.00	268.00	307.00	347.00	386.00	424.00	378.00
25	13.10	29.90	55.80	104.00	150.00	194.00	237.00	280.00	322.00	362.00	403.00	442.00	401.00
28	14.90	33.80	63.00	118.00	169.00	220.00	268.00	316.00	363.00	410.00	456.00	500.00	476.00
30	16.00	36.50	68.00	127.00	182.00	236.00	290.00	340.00	391.00	441.00	491.00	539.00	528.00
32	17.20	39.00	72.80	135.00	196.00	253.00	310.00	365.00	420.00	473.00	525.00	578.00	582.00
35	18.90	43.00	80.20	150.00	216.00	279.00	342.00	402.00	462.00	521.00	579.00	637.00	665.00
40	21.70	49.60	92.60	173.00	249.00	323.00	394.00	465.00	534.00	602.00	669.00	736.00	802.00

Note: Value in above table is for single strand chain only. For multiplex chain, please apply the coefficient of Multi-strand.
Please refer to chain selection on p.64

RC180KS

ULTIMATE POWER SERIES

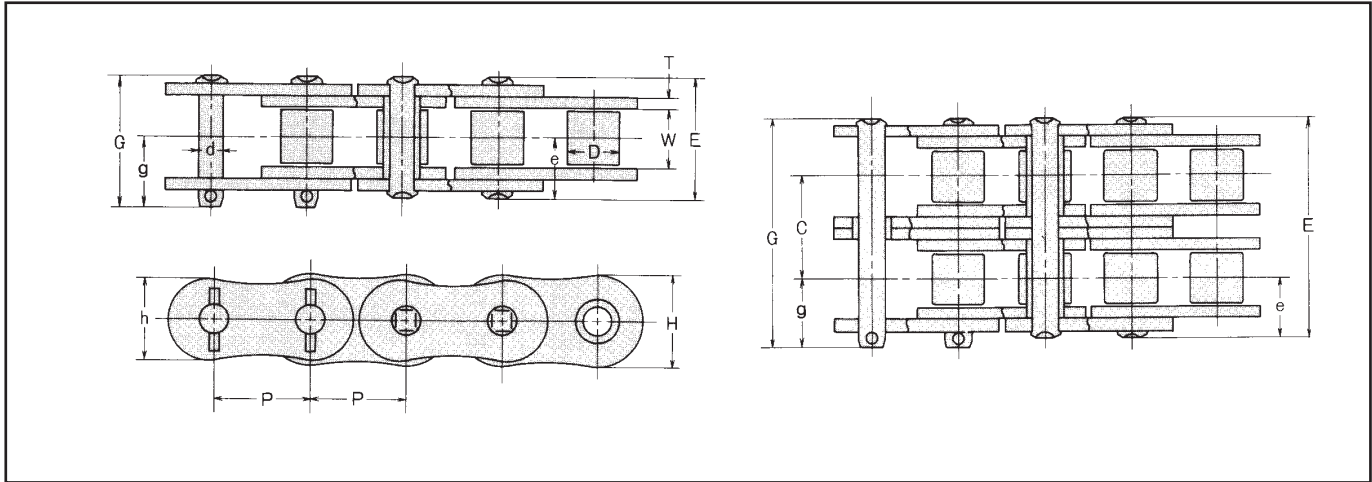

Dimensions

Unit (inch)

Chain No.	Pitch	Roller Link Width	Roller (Bush) Dia.	Pin					Transverse Pitch	Plate			JIS Min. Tensile Strength	DID Min. Tensile Strength	DID Avg. Tensile Strength	DID Max Allowable Load	Approx. Weight (lbs/ft)	
				D	d	E	G	e		g	C	T						H
RC180KS	180																	
RC180KS-2R	180-2	2.250	1.406	1.406	.687	5.409	5.638	1.409	1.638	2.591	0.280	2.134	1.835	0	84920	92400	18700	9.66
RC180KS-3R	180-3					8.004	8.232							0	169840	184800	31790	19.18
														0	254760	277200	46750	28.63

Max. Horsepower Ratings

Unit (hp)

Type of Lubrication No. of Teeth of Small Sprocket	Revolutions per minute-Small Sprocket (rpm) (Please refer to P.76 for more details regarding type of lubrication A, B and C.)									
	10	25	50	100	150	200	250	300	350	400
	A			B				C		
11	7.02	16.10	29.90	55.80	80.40	104.00	127.00	150.00	173.00	
12	7.72	17.60	32.80	61.30	88.30	114.00	139.00	165.00	189.00	
13	8.42	19.20	35.80	66.90	96.20	125.00	153.00	180.00	206.00	
14	9.12	20.80	38.90	72.40	104.00	135.00	165.00	194.00	224.00	
15	9.83	22.40	41.80	78.00	112.00	146.00	178.00	209.00	241.00	
16	10.50	24.00	44.80	83.60	121.00	155.00	190.00	225.00	259.00	
17	11.20	25.60	47.90	89.30	129.00	166.00	204.00	240.00	276.00	
18	12.00	27.30	50.90	95.00	137.00	177.00	217.00	256.00	294.00	
19	12.70	29.00	54.00	101.00	145.00	188.00	229.00	271.00	311.00	
20	13.40	30.60	57.10	106.00	153.00	198.00	243.00	286.00	328.00	371.00
21	14.10	32.20	60.20	112.00	162.00	209.00	256.00	302.00	347.00	391.00
22	14.90	33.90	63.30	118.00	170.00	220.00	269.00	318.00	365.00	412.00
23	15.50	35.50	66.40	124.00	178.00	231.00	283.00	332.00	382.00	432.00
24	16.40	37.30	69.40	130.00	186.00	241.00	296.00	349.00	401.00	452.00
25	17.00	38.90	72.70	135.00	196.00	253.00	310.00	365.00	418.00	472.00
28	19.30	44.00	82.00	153.00	221.00	286.00	350.00	412.00	473.00	534.00
30	20.80	47.30	88.30	165.00	237.00	308.00	377.00	444.00	509.00	575.00
32	22.30	50.80	94.80	177.00	255.00	330.00	403.00	476.00	546.00	615.00
35	24.50	55.90	104.00	194.00	280.00	363.00	445.00	524.00	602.00	678.00
40	28.30	64.60	121.00	225.00	324.00	420.00	513.00	605.00	694.00	784.00

Note: Value in above table is for single strand chain only. For multiplex chain, please apply the coefficient of Multi-strand. Please refer to chain selection on p.64

RC200KS

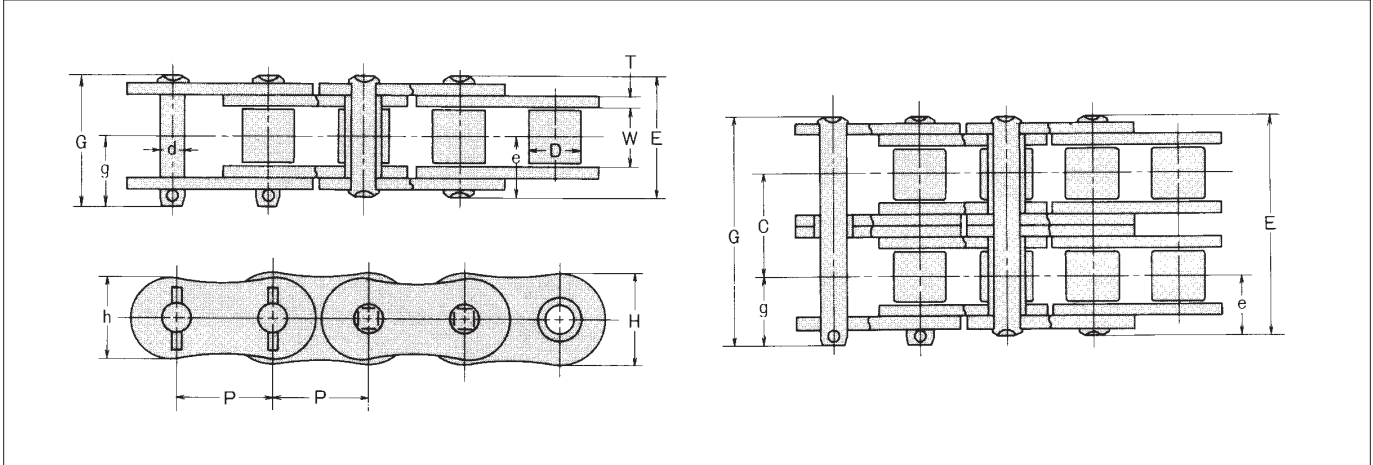

Dimensions

Unit (inch)

Chain No.		Pitch	Roller Link Width	Roller (Bush) Dia.	Pin					Transverse Pitch	Plate			JIS Min. Tensile Strength	DID Min. Tensile Strength	DID Avg. Tensile Strength	DID Max Allowable Load	Approx. Weight (lbs/ft)
DID	ANSI				P	W	D	d	E		G	e	g					
RC200KS-R	200	2.500	1.500	1.562	0.781	3.067	3.346	1.535	1.811	2.819	0.315	2.370	2.047	77845	103180	112200	22000	11.73
RC200KS-2R	200-2					5.890	6.165							155690	206360	224400	37400	23.27
RC200KS-3R	200-3					8.713	8.988							233534	309540	336600	55000	34.87

Max. Horsepower Ratings

Unit (hp)

Type of Lubrication No. of Teeth of Small Sprocket	Revolutions per minute-Small Sprocket (rpm) (Please refer to P.76 for more details regarding type of lubrication A, B and C.)											
	10	15	20	30	40	50	60	80	100	150	200	250
	A			B			C					
11	9.32	13.40	17.40	25.10	32.40	39.70	46.60	60.50	74.00	107.00	138.00	169.00
12	10.20	14.70	19.00	27.50	35.70	43.60	51.30	66.50	81.20	117.00	151.00	185.00
13	11.20	16.10	20.80	30.00	38.90	47.50	55.90	72.50	88.60	128.00	165.00	202.00
14	12.10	17.40	22.50	32.40	42.10	51.50	60.60	78.60	96.00	138.00	180.00	218.00
15	13.00	18.80	24.30	35.00	45.30	55.40	65.30	84.60	103.00	149.00	193.00	236.00
16	13.90	20.10	26.00	37.50	48.70	59.40	70.00	90.80	111.00	160.00	206.00	253.00
17	14.90	21.40	27.70	40.10	51.90	63.40	74.80	96.80	118.00	170.00	221.00	269.00
18	15.80	22.80	29.60	42.60	55.20	67.40	79.50	103.00	126.00	181.00	235.00	287.00
19	16.80	24.30	31.40	45.20	58.60	71.80	84.30	109.00	134.00	192.00	249.00	304.00
20	17.80	25.60	33.10	47.70	61.80	75.60	89.10	115.00	141.00	204.00	263.00	322.00
21	18.80	26.90	35.00	50.30	62.70	79.60	93.80	122.00	149.00	214.00	277.00	339.00
22	19.70	28.40	36.70	52.90	68.50	83.80	98.80	128.00	157.00	225.00	292.00	357.00
23	20.60	29.80	38.60	55.50	72.00	87.90	104.00	134.00	164.00	236.00	306.00	374.00
24	21.60	31.10	40.30	58.20	75.30	92.10	108.00	141.00	172.00	248.00	320.00	391.00
25	22.70	32.60	42.20	60.70	78.70	96.20	113.00	147.00	180.00	259.00	335.00	
28	25.60	36.70	47.70	68.60	89.00	109.00	128.00	166.00	202.00	292.00	378.00	
30	27.50	39.70	51.30	74.00	95.80	117.00	138.00	178.00	218.00	315.00	408.00	
32	29.50	42.50	55.10	79.40	103.00	126.00	147.00	192.00	235.00	338.00	437.00	
35	32.40	46.80	60.60	87.40	113.00	138.00	164.00	212.00	259.00	371.00	481.00	
40	37.50	54.00	70.10	101.00	131.00	160.00	188.00	244.00	298.00	429.00	556.00	

Note: Value in above table is for single strand chain only. For multiplex chain, please apply the coefficient of Multi-strand. Please refer to chain selection on p.64

RC240KS,

ULTIMATE POWER SERIES

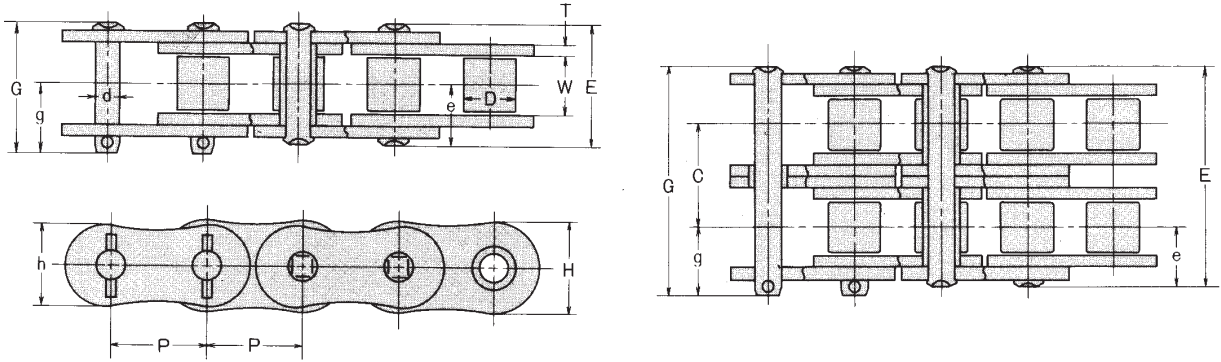

Dimensions

Unit (inch)

Chain No.		Pitch P	Roller Link Width W	Roller (Bush) Dia. D	Pin					Transverse Pitch C	Plate			JIS Min. Tensile Strength lbs	DID Min. Tensile Strength lbs	DID Avg. Tensile Strength lbs	DID Max Allowable Load lbs	Approx. Weight (lbs/ft)
DID	ANSI				d	E	G	e	g		T	H	h					
RC240KSR	240	3.000	1.875	1.875	0.937	3.748	4.051	1.878	2.177	3.457	0.374	2.843	2.441	112259	149600	162800	29700	16.56
RC240KS-2R	240-2					7.209	7.512							224519	299200	325600	50490	32.86
RC240KS-3R	240-3					10.665	10.969							336778	448800	488400	74250	49.15

Max. Horsepower Ratings

Unit (hp)

Type of Lubrication No. of Teeth of Small Sprocket	Revolutions per minute-Small Sprocket (rpm) (Please refer to P.76 for more details regarding type of lubrication A, B and C.)													
	5	10	15	20	25	30	40	50	60	80	100	125	150	
	A			B			C							
11	7.98	14.90	21.40	27.70	33.90	39.90	51.70	63.30	74.70	96.60	118.00	145.00	170.00	
12	8.75	16.40	23.60	30.60	37.30	44.00	57.00	69.60	81.90	106.00	130.00	158.00	186.00	
13	9.54	17.80	25.60	33.20	40.60	47.90	62.10	75.90	89.40	116.00	142.00	173.00	204.00	
14	10.30	19.30	27.70	36.10	44.00	51.90	67.20	82.20	96.80	125.00	153.00	188.00	221.00	
15	11.10	20.80	29.90	38.90	47.50	55.90	72.40	88.50	104.00	135.00	165.00	202.00	237.00	
16	11.90	22.30	32.20	41.60	50.80	59.90	77.60	94.90	112.00	145.00	177.00	216.00	255.00	
17	12.80	23.90	34.30	44.40	54.30	63.90	82.80	101.00	119.00	154.00	189.00	231.00	272.00	
18	13.50	25.30	36.50	47.30	57.80	68.10	88.20	108.00	127.00	165.00	201.00	245.00	290.00	
19	14.30	26.80	38.60	50.10	61.30	72.10	93.40	114.00	134.00	174.00	213.00	260.00	307.00	
20	15.10	28.40	40.90	52.90	64.70	76.30	98.80	121.00	142.00	185.00	225.00	276.00	324.00	
21	16.10	29.90	43.00	55.80	68.20	80.40	104.00	127.00	150.00	194.00	237.00	291.00	342.00	
22	16.90	31.500	45.30	58.70	71.70	84.60	110.00	134.00	158.00	204.00	249.00	306.00		
23	17.70	33.00	47.60	61.50	75.20	88.70	115.00	141.00	165.00	214.00	263.00	320.00		
24	18.50	34.60	49.70	64.50	78.80	92.90	120.00	147.00	173.00	224.00	275.00	335.00		
25	19.30	36.10	52.00	67.40	82.30	97.10	126.00	154.00	181.00	235.00	287.00	351.00		
28	21.80	40.80	58.70	76.10	93.00	110.00	142.00	174.00	205.00	265.00	324.00	397.00		
30	23.60	44.00	63.30	82.00	100.00	118.00	153.00	188.00	220.00	286.00	349.00	426.00		
32	25.20	47.20	67.80	87.90	108.00	127.00	164.00	201.00	236.00	306.00	374.00	457.00		
35	27.90	51.90	74.80	96.90	118.00	139.00	181.00	221.00	260.00	338.00	413.00			
40	32.20	59.90	86.30	112.00	137.00	161.00	209.00	255.00	300.00	390.00	476.00			

Note: Value in above table is for single strand chain only. For multiplex chain, please apply the coefficient of Multi-strand. Please refer to chain selection on p.64

2-2-3 **DID** HI*PWR HK Series Roller Chain

ULTIMATE POWER SERIES

Features

HK type roller chain conform to H type of ANSI, and their inner and outer plates are equal in thickness to those of the next larger size of standard roller chain. Therefore, the tensile strength is higher by approximately 20% and the maximum allowable load is higher by approximately 15% compared to D.I.D ANSI standard roller chain. However, since the weight of the chain is also larger, the performance at high speed declines. So, HK type roller chain are suitable for heavy duty at low speed.



Multiplex chain and sprockets

HK type roller chain are available up to triplex. Since the transverse pitches (C dimension: see P.40) are larger than those of standard chain in the case of duplex or triplex, standard sprockets cannot be used.

Selection of chain

Select a proper HK type roller chain based on "Slow-speed selection". For the maximum allowable load, see the following table of dimensions.

The tensile strength of connecting links and offset links are listed below, but the maximum allowable load is somewhat lower than that of the base chain.

HK Series Connecting Link and Offset Link

	Connecting Link		Offset Link	
	Clearance Fit	Interference Fit	Clearance Fit	Interference Fit
Connecting Link Applicable	Clip: RC50 & under Clip/Cotter: RC60	Clip: RC50 & under Roll Pin: RC80 & over Clip/Cotter: RC60	Offset Link Unavailable for RC40HK & Smaller	2 Pitch Offset Link Unavailable for RC40HK & Smaller
Tensile Strength	Same as chain body	Same as chain body	Same as chain body	Same as chain body

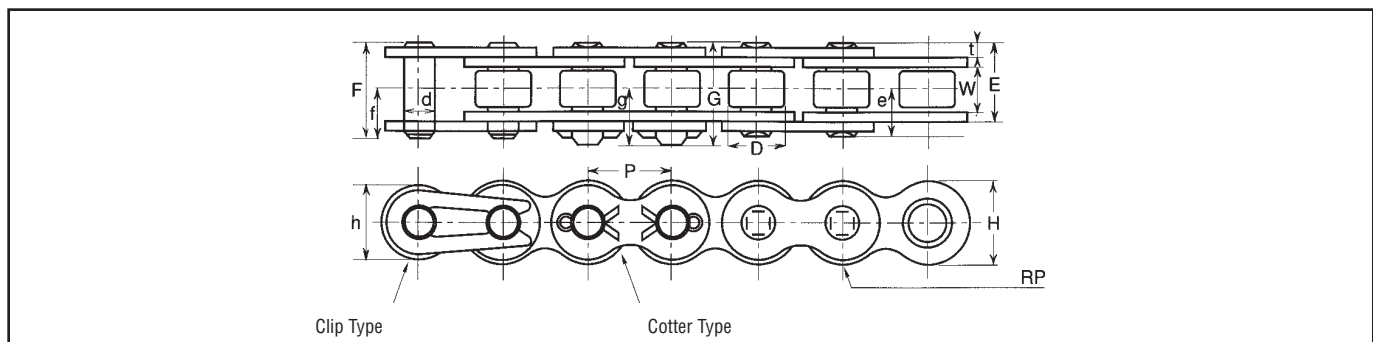

Dimensions

Unit (inch)

Chain No. DID	Pitch P	Roller Link Width W	Roller Dia. D	Pin						Plate			Min. Tensile Strength lbs	Avg. Tensile Strength lbs	Max Allowable Load lbs	Approx. Weight (lbs/ft)
				d	E	F	G	f	g	T	H	h				
RC50HK	0.625	0.375	0.400	0.200	0.858	0.921		0.496		0.094	0.591	0.512	7480	8140	1936	0.75
RC60HK	0.750	0.500	0.469	0.235	1.130	1.201	1.228	0.634	0.665	0.126	0.713	0.614	10560	11660	2420	1.21

HI*PWR HK Series Roller Chain

ULTIMATE POWER SERIES

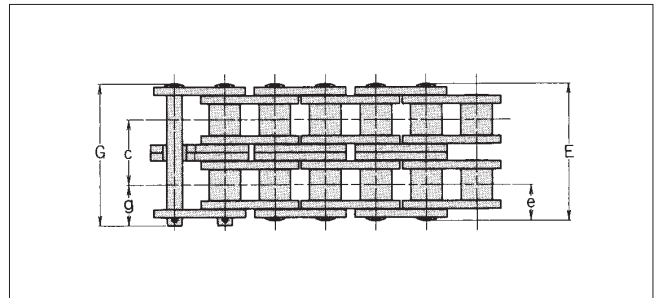
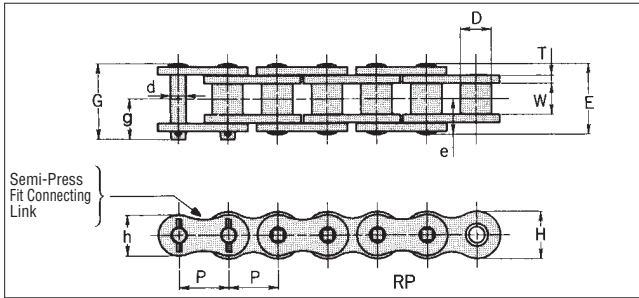

Dimensions

Chain No. DID	Pitch P	Roller Link Width W	Roller Dia. D	Pin					C	Plate			Min. Tensile Strength lbs	Avg. Tensile Strength lbs	Max Allowable Load lbs	Approx. Weight (lbs/ft)
				d	E	G	e	g		T	H	h				
RC80HK	1.000	0.625	0.625	0.313	1.421	1.524	0.713	0.811	1.283	0.157	0.945	0.819	18260	21560	3740	1.99
RC80HK-2						2.697	2.807						36520	43120	6358	3.94
RC80HK-3						3.984	4.094						54780	64680	9350	5.87
RC100HK	1.250	0.750	0.750	0.376	1.717	1.819	0.858	0.961	1.539	0.189	1.177	1.024	27720	31900	5940	2.79
RC100HK-2						3.228	3.350						55440	63800	10098	5.52
RC100HK-3						4.768	4.886						83160	95700	14850	8.23
RC120HK	1.500	1.000	0.875	0.437	2.130	2.244	1.067	1.177	1.925	0.220	1.413	1.228	37400	42900	7700	4.08
RC120HK-2						4.024	4.154						74800	85800	13090	8.07
RC120HK-3						5.949	6.079						112200	128700	19250	12.03
RC140HK	1.750	1.000	1.000	0.500	2.280	2.445	1.142	1.311	2.055	0.252	1.650	1.429	48840	56100	10120	5.91
RC140HK-2						4.299	4.488						97680	112200	17204	11.69
RC140HK-3						6.354	6.543						146520	168300	25300	17.43
RC160HK	2.000	1.250	1.125	0.563	2.677	2.843	1.339	1.504	2.437	0.280	1.882	1.630	62260	71500	13200	7.33
RC160HK-2						5.272	5.319						124520	143000	22440	14.51
RC160HK-3						7.701	7.760						186780	214500	33000	21.62
RC180HK	2.250	1.406	1.406	0.687	2.972	3.189	1.488	1.705	2.724	0.315	2.118	1.835	90200	99000	16060	9.93
RC180HK-2						5.906	5.984						180400	198000	27302	19.66
RC180HK-3						8.634	8.713						270600	297000	40150	29.30
RC200HK	2.500	1.500	1.562	0.781	3.323	3.594	1.661	1.945	3.083	0.374	2.362	2.047	109120	125400	18700	12.85
RC200HK-2						6.693	6.783						218240	250800	31790	25.45
RC200HK-3						9.780	9.870						327360	376200	46750	37.92
RC240HK	3.000	1.875	1.875	0.937	4.252	4.551	2.126	2.429	3.984	0.500	2.815	2.441	172260	198000	25300	18.98
RC240HK-2						8.567	8.665						344520	396000	43010	37.57
RC240HK-3						12.551	12.650						516780	594000	63250	55.98

Note: The above chains are of riveted pin type (RP). As for cottered pin type (CP), please consult us.

2-2-4 **DID** HI*PWR HKS Series Roller Chain

ULTIMATE POWER SERIES

Features

The DID HKS series roller chain have thicker linkplates than KS type roller chain, and are the highest in tensile strength and allowable load among general application chains. Thus being suitable for low speed heavy duty transmission. The HKS roller chains are 20 percent higher in tensile strength and 50 percent higher in maximum allowable load than the standard roller chain, but since they are also higher in weight, they are lower in performance at high speed. So, they are suitable for heavy duty at low speed.



Number of strands and sprockets

The HKS type roller chain are simplex. As for sprockets, standard sprockets for simplex chain can be used. For multiplex chain, please consult us.

Connecting links

The best feature of the HKS type roller chain is that they are high in maximum allowable load. Therefore, interference-fitted connecting links are used. The connection between the connecting plate and the connecting pins is achieved by roll pins. The tensile strength of connecting link is equivalent to that of the base chain but the maximum allowable load is somewhat lower than that of the base chain.

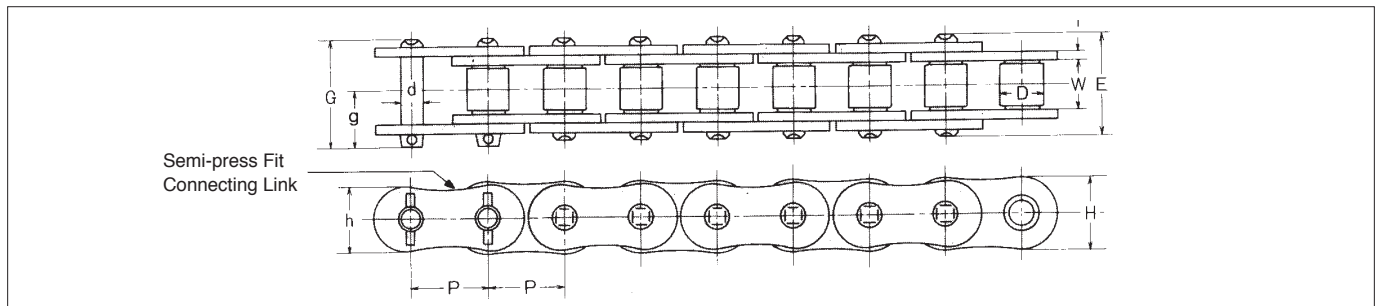

Dimensions

Unit (inch)

Chain No. DID	Pitch	Roller Link Width	Roller Dia.	Pin				Plate			Min. Tensile Strength	Avg. Tensile Strength	Max Allowable Load	Approx. Weight (lbs/ft)
	P	W	D	d	E	G	g	T	H	h	lbs	lbs	lbs	
RC80HKS	1.000	0.625	0.625	0.313	1.421	1.524	0.811	0.157	0.949	0.819	19,140	22,000	5,060	2.09
RC100HKS	1.250	0.750	0.750	0.376	1.717	1.819	0.961	0.189	1.185	1.024	28,380	32,560	7,700	2.93
RC120HKS	1.500	1.000	0.875	0.437	2.130	2.244	1.177	0.220	1.425	1.228	38,280	44,000	10,120	4.28
RC140HKS	1.750	1.000	1.000	0.500	2.280	2.445	1.311	0.252	1.669	1.429	49,720	57,200	13,640	6.20
RC160HKS	2.000	1.250	1.125	0.563	2.677	2.843	1.504	0.280	1.898	1.630	63,140	72,600	17,380	7.70
RC180HKS	2.250	1.406	1.406	0.687	2.972	3.189	1.705	0.315	2.134	1.835	94,600	103,400	20,460	10.43
RC200HKS	2.500	1.500	1.562	0.781	3.323	3.594	1.945	0.374	2.370	2.047	116,600	134,200	25,300	13.50
RC240HKS	3.000	1.875	1.875	0.937	4.252	4.551	2.429	0.500	2.843	2.441	179,960	206,800	34,980	19.93

2-3 DID[®] Ultimate Life Chain Series

TRANSMISSION
ROLLER CHAIN

ULTIMATE POWER SERIES

The DID general application chain are used for various applications, and it can sometimes happen that if they are used without any lubrication at all or in a dusty environment, they cannot maintain the wear life they are designed for. In such a case, we recommend the Ultimate Life Chain Series. The Ultimate Life Chain Series includes Long life chain, Dai-hard chain, O-ring chain and Sintered bushing roller chain. The features of the respective chain are described below.

V Grease chain

A long life chain uses dimensionally accurate solid bushings (split bushings in the case of standard roller chain), to increase the beating area with the pins for achieving a longer wear life. If a long life chain is used with grease lubrication, the life becomes longer than that of a standard roller chain. Furthermore, if a long life chain is used with D.I.D patented V grease, the chain will have a much longer wear life. (A long life chain can be effectively decreased in initial wear even in a place abundant in oil without grease lubrication.)

DHA chain

This chain has a pin which is treated with D.I.D's patented process that creates an extremely hardened carbide layer, resisting wear even in adverse conditions including the presence of abrasive contaminants. It exhibits excellent performance even under the conditions where lubrication is not permitted.

O-ring chain

Grease is sealed with O-rings between pin and bushing. It can be used in a very wide range of applications from low speed to high speed and from light duty to heavy duty, ensuring the longest of life. O-ring chain is the best chain among chains, and in view of heavy duty, high speed and maintenance free, this chain is highest in performance. Furthermore, it is durable to some extent even at high temperature, and a chain adopting heat resistant O-rings has actually been used in a 392°F oven. (Since the pin length becomes longer by two O-rings, refer to the table of dimensions for chain selections.)

Sintered bushing roller chain

Sintered bushing roller chain uses bushings made of sintering alloy steel powder. The porous spaces of the sintered bushings are impregnated with oil beforehand, to increase the life of the chain. It is a maintenance free chain that lubricates itself during operation and offers extended wear life. The chain is very suitable for applications where the chain cannot be lubricated during the operation. Furthermore, since the chain has little oil deposit on the outside, it can be used in a place where a cleanliness is required. However, Sintered bushing roller chain is for low speed and light duty applications. For severe environments exposed to water or dust, etc., the use of an environment resistant chain (P. 52) or O-ring chain is recommended.

Ultimate Life, Environment Resistance, Low Noise Series chain

Chain Size	Ultimate Life Series				Environment Resistance Series				Low Noise Chain
	V Grease	DHA	O-Ring	Sintered Bush	Rustless (Nickel Plated)	Hi-Guard	Low Temp.	Stainless	Low Noise
RC25	T	DHA			N	E		SS	
RC35	T	DHA			N	E		SS	
RC41		DHA			N				
RC40	D	DHA	LLDR	UR	N	E	TK	SS	LN
RC50	D	DHA	LLDR	UR URN	N	E	TK	SS	LN
RC60	D	DHA	LLDR	UR URN	N	E	TK	SS	LN
RC80	D		LDR	UR URN	N	E	TK	SS	LN
RC100	D		LDR		N	E	TK	SS	
RC120			LDR		N	E	TK	SS	
RC140			LDR		N		TK	SS	
RC160			LDR		N		TK	SS	
RC200			LDR						
RC240			LDR						

Note: 1. The chain no. is indicated with the letters in the table following the chain size.
For example, RC50DHA
2. UR: Sintered Bushing Roller Chain
URN: Rustless Sintered Bushing Roller Chain

2-3-1 Selection of Ultimate Life Chain Series

In general, refer to the following criteria when you select an Ultimate Life Chain.

Wear of chain in contaminated oil

1. In a place to allow good lubrication without dust, even a standard roller chain can be expected to be very long in life. However, in general, even in "good lubrication", the entering of worn powder and "contamination" due to deteriorated oil cannot be avoided. Contamination can remarkably shorten the life of chain.
2. If you wish to prevent the shortening of wear life even with "contamination", use Solid bushing chain. Solid bushing chain has accurate solid bushings, to increase the bearing area, and unlike split bushings, oil does not leak from the seam of the split bushing.
3. If you need even longer life, DHA chain is recommended. DHA chain even in contaminated oil has a life of three to seven times longer than standard chain.

Chain wear due to no maintenance

If lubrication and maintenance are impossible or difficult, the initial grease applied in the factory is all the lubrication, and it can happen that the chain could not last long enough as needed. If you need adequate long life even though lubrication and maintenance are difficult, O-ring chain or Sintered bushing roller chain is recommended. O-ring chain can be dependable even in a dusty severe environment in a range from low speed to high speed.

Wear of chain in a dusty place

O-ring chain or DHA chain is effective in this condition. An O-ring chain is the most suitable. O-ring chain has special grease vacuum sealed between pin and bushing preventing the penetration of dust from outside, ensuring long life. For applications where O-ring chain can not be utilized, DHA chain is recommended. DHA chain has excellent wear resistance because of the surface hardness of the pins. The performance of Ultimate Life Chain Series is listed in the following comparison table. For selecting the proper chain, please refer to the table.

Cautions for sintered bushing roller chain

1. Sintered bushing roller chain is available as a series from RC40 to RC80(UR).
2. Do not use a sintered bushing roller chain in a dusty place.
3. Sintered bushing roller chain is not recommended for applications subject to shock loads. Sintered bushing chain is designed for slow speed and light duty applications.

Cautions for sealed chain

1. O-ring chain LLDR/LDR is available as a series from RC35LLDR to RC240LDR.
2. Please bear in mind in your design work, that an O-ring chain has longer pins than a standard roller chain. An O-ring chain is equivalent to a standard roller chain in strength.
3. An O-ring chain is not recommended for an environment in which the nitrile rubber O-ring could be damaged. An environment in which nitrile rubber is eroded means generally an application where any of the following chemical materials is used.

Gasoline, kerosene, benzene, toluene, trichloroethene, ether, ketone (MEK), ethyl acetate, phosphoric acid, ester based working fluid, organic acid, highly concentrated inorganic acid

Comparison Chart of Wear Resistant Chain Series

Chain Size		Comparison in strength		Anti wear performance index				Available Temperature Range
				Lubrication to be always possible		Lubrication possible (initial lubrication only)		
		Max. Allowable Load Ratio	Chain Selecting method	Clean lubricant	Used or degraded lubricant	Normal(dust free) condition	Normal(dust free) condition	
Standard Roller Chain	—	100%	Maximum Horsepower Rating or Slow-Speed Selection	1.0	1.0	1.0	1.0	-10°C~80°C (14°F~176°F)
V Grease Solid Bushing	T D	100%		1.3	1.2~1.5	1.5~3	1.8~4	-10°C~80°C (14°F~176°F)
DHA Chain	DHA	100%		1.5~2	3~7	1.3	1.2~3	-10°C~100°C (14°F~212°F)
O-Ring Chain	LLDR LDR	100%		—	—	5~12	5~20	-10°C~80°C (14°F~176°F)
Sintered Bushing Roller Chain	UR URN	70%	Maximum Horsepower Rating or Slow-Speed Selection	—	—	Approx. 5 on Slow-Speed and Medium duty	Not available	-10°C~60°C (14°F~140°F)

Note: 1. Wear resistance performance shows an index compared with standard roller chain as 1.0
2. It is also available in O-ring chain which can be used over 176°F. Please consult with us.

2-3-2 DID[®] V Grease Series



Daido's "D" AND "T" Series roller chain is manufactured with a cold forged bushing and is lubricated with a Daido patented V-Grease. This lubricant extends the wear life up to 4 times longer than conventional ANSI standard roller chain. This patented V-Grease adheres to the chain in high revolution applications and resists being washed away in outdoor usage. Daido's D & T Series chain is one of the lowest cost upgrades available for your roller chain requirements.



TRANSMISSION
ROLLER CHAIN

ULTIMATE LIFE
CHAIN SERIES

Design of chain transmission

A solid bushing chain has the same strength as a standard roller chain.

Connecting links and offset links

For the connecting links and offset links of a solid bushing chain, use standard roller chain series. For RC25HT, no offset link is available.

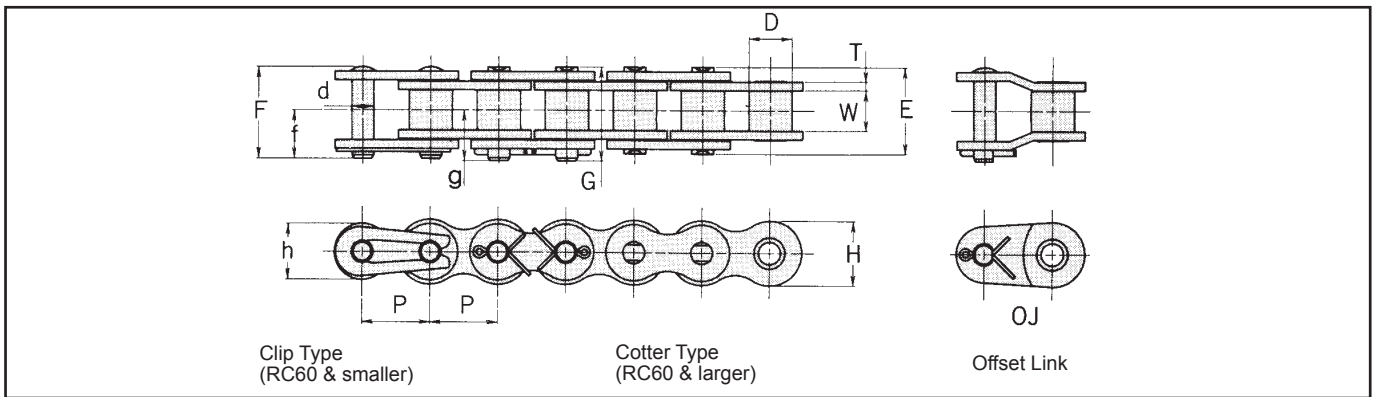

Dimensions

Unit (inch)

Chain No. DID	Pitch P	Roller Link Width W	Roller (Bush) D	Pin						Plate			Avg. Tensile Strength lbs	Max. Allowable Load lbs	Approx. Weight (lbs/ft)
				d	E	F	G	f	g	T	H	h			
*RC25HT	0.250	0.125	0.130	0.091	0.354	0.374	–	0.205	–	0.039	0.232	0.205	1320	242	0.107
*RC35T	0.625	0.375	0.200	0.141	0.472	0.516	–	0.287	–	0.049	0.354	0.305	2530	484	0.215
RC40D	0.750	0.500	0.312	0.156	0.650	0.693	–	0.374	–	0.059	0.472	0.409	4290	836	0.422
RC50D	1.000	0.625	0.400	0.200	0.799	0.862	–	0.457	–	0.079	0.591	0.512	6930	1540	0.711
RC60D	0.750	0.500	0.469	0.235	1.000	1.059	1.098	0.563	0.594	0.094	0.713	0.614	9900	2090	0.966
RC80D	1.000	0.625	0.625	0.313	1.283	0.000	1.394	0.000	0.748	0.126	0.945	0.819	17600	3300	1.710
RC100D	1.250	0.750	0.750	0.376	1.555	0.000	1.673	0.000	0.898	0.157	1.177	1.024	26620	5060	2.541

Note: Those marked with * indicate bush chains.

2-3-3 DID[®] DHA Chain

Perfect lubrication extends the life of the chain. However, it is not easy to avoid lubricating oil that is deteriorated by the oxidation of the lubricating oil itself, penetration of wear residue and dust, etc. In such situations, the DHA chain is recommended. Even in such severe environments where hard and fine particles are evident without any lubricating oil at all, the DHA chain shows excellent performance.

Structure of DHA

DHA refers to a hard layer formed on the surface of a pin. This layer has a very hard chromium carbide surface as illustrated in the top illustration. Excellent performance can be expected even in adverse conditions including the presence of abrasive contaminants. Furthermore, the DHA pins have excellent rust protection on pins. The following table compares the properties of DHA with other surface treatments.

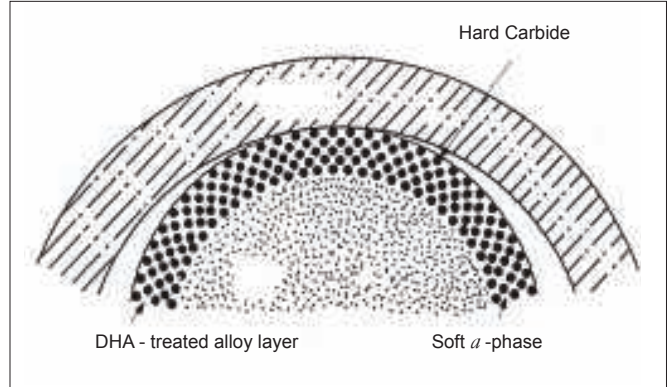

DHA - treated alloy layer Soft α -phase



The white layer is a layer produced by DHA treatment, and the black grains visible in the layer are chromium carbide

TRANSMISSION
ROLLER CHAIN

Comparison of properties

	Carburizing	Nitriding	H-Cr plating	DHA
Contents of layer	High Carbon	Iron Nitride	Chrome	Chrome Carbide
Surface hardness	750~850	750~1,100	900~1,100	1,300~1,500
Practical thickness of treated layer (μ)	100 & over	10 & over	10~100	5~20
Surface hardness lowering temp.(°F)	392 & over	932 & over	572 & over	1652 & over
Peeling resistance	○	○	×	○
Wear resistance	△	○	○	○

- Excellent
- △ Fair
- × Poor

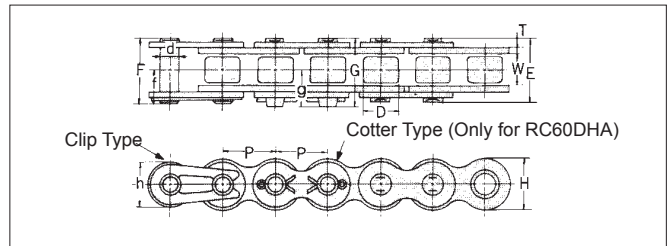

Dimensions

Chain No. DID	Pitch P	Roller Link Width W	Roller (Bush) Dia. D	Pin						Plate			Avg. Tensile Strength lbs	Max. Allowable Load lbs	Approx. Weight
				d	E	F	G	f	g	T	H	h			
				Unit (inch)											
* RC25R-DHA	0.250	0.125	0.130	0.091	0.307	0.335	—	0.185	—	0.028	0.232	0.205	990	165	0.087
* RC35R-DHA	0.375	0.188	0.200	0.141	0.472	0.516	—	0.287	—	0.049	0.354	0.305	2530	484	0.215
RC41R-DHA	0.500	0.251	0.306	0.141	0.539	0.575	—	0.311	—	0.047	0.378	0.315	2420	528	0.262
RC40R-DHA	0.500	0.313	0.312	0.156	0.650	0.693	—	0.374	—	0.059	0.472	0.409	4290	836	0.422
RC50R-DHA	0.625	0.375	0.400	0.200	0.799	0.862	—	0.457	—	0.079	0.591	0.512	6930	1540	0.711
RC60R-DHA	0.750	0.500	0.469	0.235	1.000	1.059	1.098	0.563	0.594	0.094	0.713	0.614	9900	2090	0.966

Note: Those marked with * indicate bush chain.

Wear resistance of DHA

Test results for “wear resistance in a deteriorated lubrication condition” and “wear resistance in a sand dust environment” are shown below.

The results show the excellent performance of DHA.

Applications where a DHA chain can be effectively used are provided on the right for your reference.

Applications where a DHA chain can be effectively used

An application where soil, sand or dust directly come in contact with the chain (if an O-ring chain can be used in the application, the use of an O-ring chain is more effective).

An application where a chain is lubricated in an oil bath, etc. but where the oil is heavily deteriorated due to the penetration of foreign objects.

Test Results for Wear Resistance Comparison

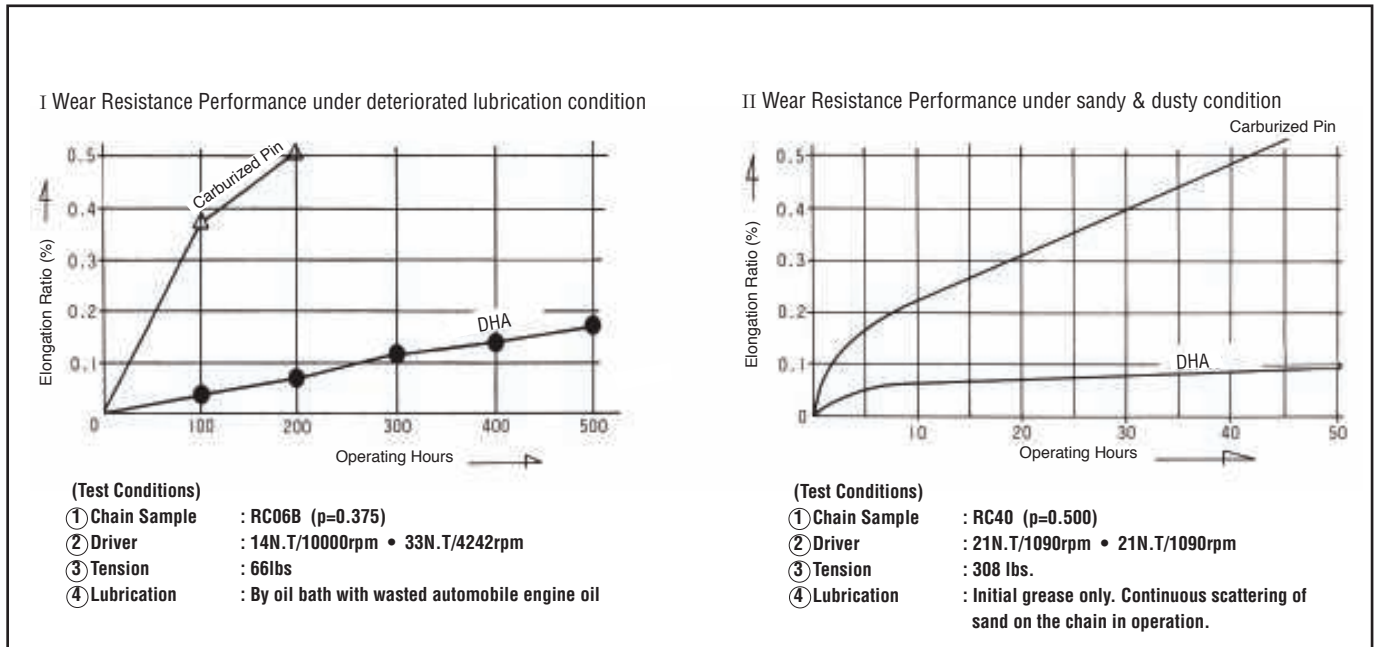

Design of chain transmission

DHA chain is quite the same as a standard roller chain in strength. So, for selecting a proper DHA chain, please call customer service at Daido Corporation of America. For the maximum horsepower rating, see the table of maximum horsepower ratings for standard roller chain.

Connecting links and offset links

As for the connecting links and offset links of a DHA chain, use those of a standard roller chain. The reason is that while a chain as a whole has many links, the numbers of connecting links and offset links is 1 to 2, therefore their influence on the wear of the entire chain is small.

2-3-4 DID[®] O-Ring/X-Ring Chain (LLDR/LDR)

DID O-ring chain is dramatically improved in durability, since grease is sealed between the pins and bushings by O-rings. O-ring chain is recommended for applications which provide abrasive conditions require frequent maintenance or where sintered bushing roller chain is not applicable due to its insufficient shock load capacity or high speed capacity.

RC40LLDR - RC60LLDR, the most popular sizes are furnished with X-Ring[™] instead of conventional O-Ring. The X-Ring[™] chain provides half the friction and as long as 1.5 times of wear life compared to the same size O-Ring chains.

The Big LD Series, large size O-Ring chains from RC140LLDR through RC240LLDR, is also available. This series features nut type cotter pin style connecting links for easy installation.

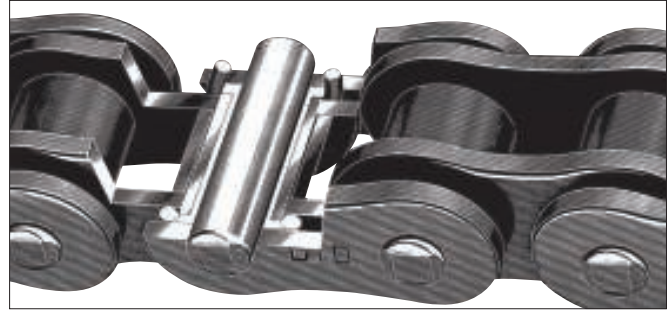

TRANSMISSION
ROLLER CHAIN

ULTIMATE LIFE
CHAIN SERIES

Dimensions

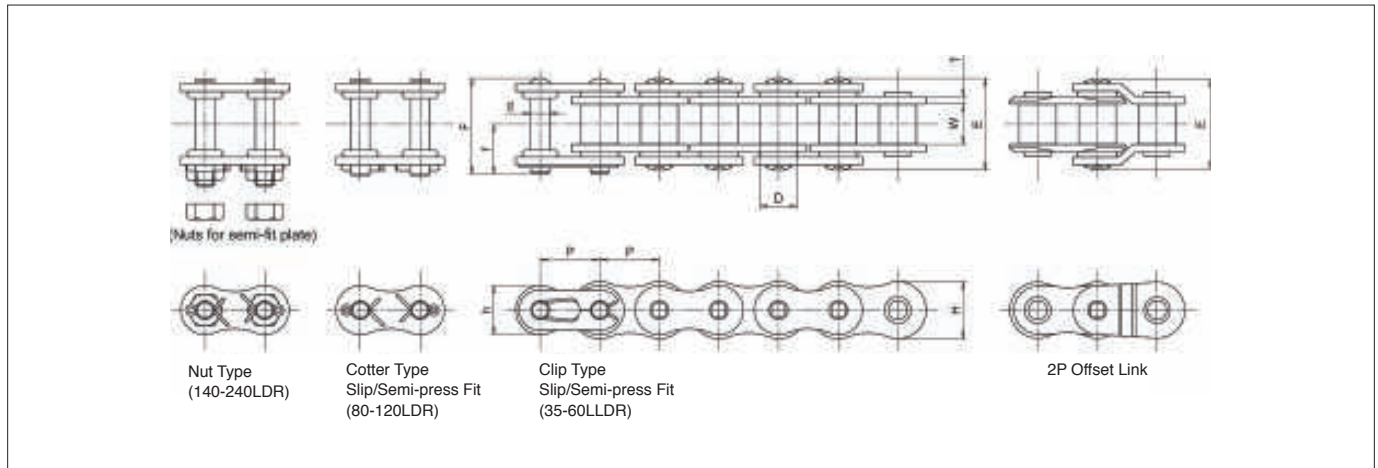

Dimensions

Chain No. DID	Pitch P	Roller Link Width W	Roller (Bush)Dia. D	Pin				Plate			Avg. Tensile Strength lbs	Max. Allowable Load lbs	Approx. Weight
				d	E	F	f	T	H	h			
* RC35LLDR	0.375	0.181	0.200	0.141	0.512	0.569	0.307	0.049	0.354	0.305	2200	330	0.235
RC40LLDR	0.500	0.313	0.312	0.156	0.787	0.787	0.421	0.059	0.472	0.409	4070	836	0.449
RC50LLDR	0.625	0.375	0.400	0.200	0.921	0.941	0.504	0.079	0.591	0.512	6754	1540	0.724
RC60LLDR	0.750	0.500	0.469	0.235	1.150	1.181	0.630	0.094	0.713	0.614	9614	2090	1.086
RC80LDR	1.000	0.625	0.625	0.313	1.437	1.531	0.823	0.126	0.941	0.811	16280	3300	1.898
RC100LDR	1.250	0.750	0.750	0.376	1.732	1.819	0.972	0.157	1.177	1.024	24200	5060	2.729
RC120LDR	1.500	1.000	0.875	0.437	2.126	2.236	1.189	0.189	1.413	1.228	35200	6820	3.956
RC140LDR	1.750	1.000	1.000	0.500	2.307	2.724	1.583	0.220	1.650	1.429	44000	9020	5.277
RC160LDR	2.000	1.250	1.125	0.563	2.717	3.161	1.819	0.252	1.882	1.630	55000	11880	6.913
RC200LDR	2.500	1.500	1.562	0.781	3.299	3.799	2.165	0.315	2.362	2.047	96140	16500	11.326
RC240LDR	3.000	1.875	1.875	0.937	3.984	4.583	2.606	0.374	2.815	2.441	140140	22220	16.630

- Note: 1. Those marked with * indicates bush chain
 2. Please connect with bolt type connecting link by using nuts. The nuts should be used only for press-fitting of link plates.
 3. RC40LLDR - RC60LLDR are X-Ring Chain

Wear Resistance Performance

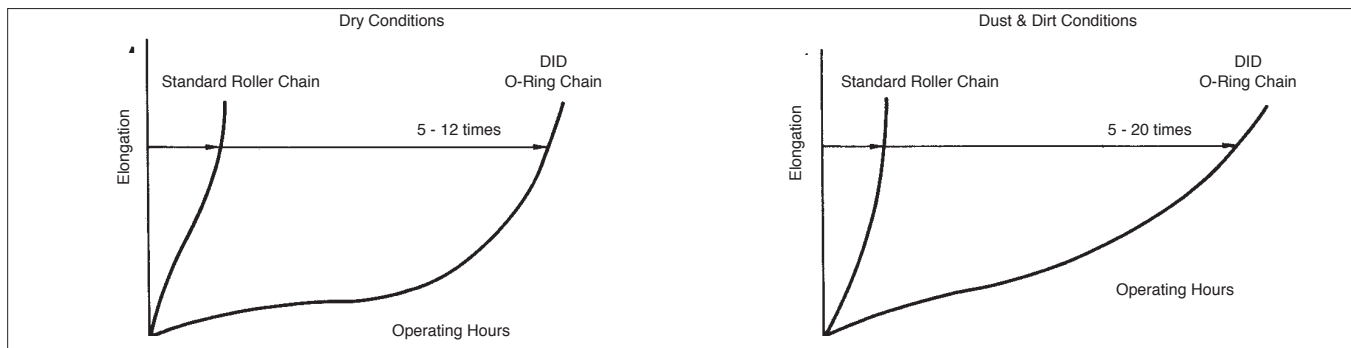

Design of chain transmission

O-ring chain is almost the same as a standard roller chain in strength. (Since the pins are longer than those of standard roller chain, the average tensile strength is slightly lower.) Therefore, design the chain transmission as you would do with standard roller chain.

If the service environment temperature is higher than 176°C, special heat resistant O-ring must be used. In this case, contact us for more information.

Maintenance

Even an O-ring chain can exhibit increased wear life with additional lubrication added during service. This additional lubrication also has the effect of rust prevention. However, do not use such chemical materials as gasoline, phosphoric acid, ester based working fluids, benzene, trichlene and acetone, since the O-rings may be damaged. Suitable oil is SAE10W to SAE50W.

Connecting Link and Offset Link

Two types of connecting links are available: Clearance Fit connecting links (clip/cotter) and Interference Fit connecting links (clip/cotter). If strength and/or durability is critical, use Interference Fit connecting links. Offset links are only available in 2 pitch style.

Chain No. DID	Connecting Link		Offset Link
	Clearance Fit	Interference Fit	
RC35LLDR	—	Clip type	2 Pitch offset link
RC40LLDR RC50LLDR RC60LLDR	Clip type	Clip type	
RC80LDR	—	Cotter pin type	
RC100LDR	Cotter pin type		
RC120LDR	—		
RC140LDR RC160LDR RC200LDR RC240LDR	—	Cotter pin type	

Chain No. DID	Connecting Link		Offset Link
	Clearance Fit	Interference Fit	
06BLDR	Clip type	—	—
08BLDR 10BLDR 12BLDR	Clip type		
16BLDR	Cotter pin type		

06NLDR	—	Clip type	—
08NLDR 10NLDR 12NLDR	—	Clip type	—

DID O-ring Chain Series

There are 5 types of O-Ring Chain for various uses. They can be applied under severe conditions where periodic lubrication is not practical.

Heat resistant O-ring chain is available in the following table, and are equipped with an X-Ring, with wear resistance 1.5 times better than that of normal O-Ring chains.

LLDR(LDR)	featuring SOLID BUSHING
LLDRS (LDRS)	featuring SOLID BUSHING & HEAT-RESISTENT RUBBER O-RING (Up to about 120°C/248°F)
LLDRSS (LDRSS)	featuring SOLID BUSHING & HEAT-RESISTANT RUBBER O-RING (Up to about 200°C/392°F)
LLDRSP (LDRSP)	equals LLDRS, except for its O-RING: LLDRSP has an X -RING.
LLDRSSP (LDRSSP)	equals LDRSS, except for its O-RING: LLDRSSP has an X -RING.

* For heat resistant O-Ring Chain, please consult us for availability

Service limit of O-ring chain

If even one O-ring comes off or when chain elongation reaches the corresponding value in the following table, immediately replace the chain with a new one. The table shows the critical elongations at which the effect of a sealed ring ceases. If the corresponding value is exceeded, wear increases as in the case of standard roller chain.

# of Teeth Large Sprocket	Max. Allowable Elongation Ratio for Non O-Ring Chain	Max. Allowable Elongation Ratio for O-Ring Chain
40 and under	2.0%	1.0%
41~60	1.5%	1.0%
61~80	1.2%	1.0%
81~100	1.0%	1.0%
101 and over	0.8%	0.8%

Other features of O-ring chain

- O-ring chain has a silencing effect. (According to tests, the noise level is 3 dB less compared to a standard roller chain.)
- O-ring chain has friction in bending. However, the power loss is almost negligible, since the frictional force acting between the pins and bushing when a load acting on the chain is greater.

2-3-5 **DID** UR (URN/URF) Chain and Maximum HP Ratings

DID UR roller chain has bushings made of a sintered alloy which is impregnated with lubricating oil during manufacture. The sintered bushing roller chain is a maintenance-free chain suitable for applications where lubrication is not permitted. In appearance sensitive applications, a rustless (URN) is recommended (for rustless chain, see P.53). In applications, limit the traveling speed 492 ft/min. or less. For a dusty environment, the use of an O-ring chain is recommended.

URF is the heat resistant version of UR chain which is applicable up to 400°F. The wear life at 400°F is two times as long as the regular UR chain.



TRANSMISSION
ROLLER CHAIN

ULTIMATE LIFE
CHAIN SERIES

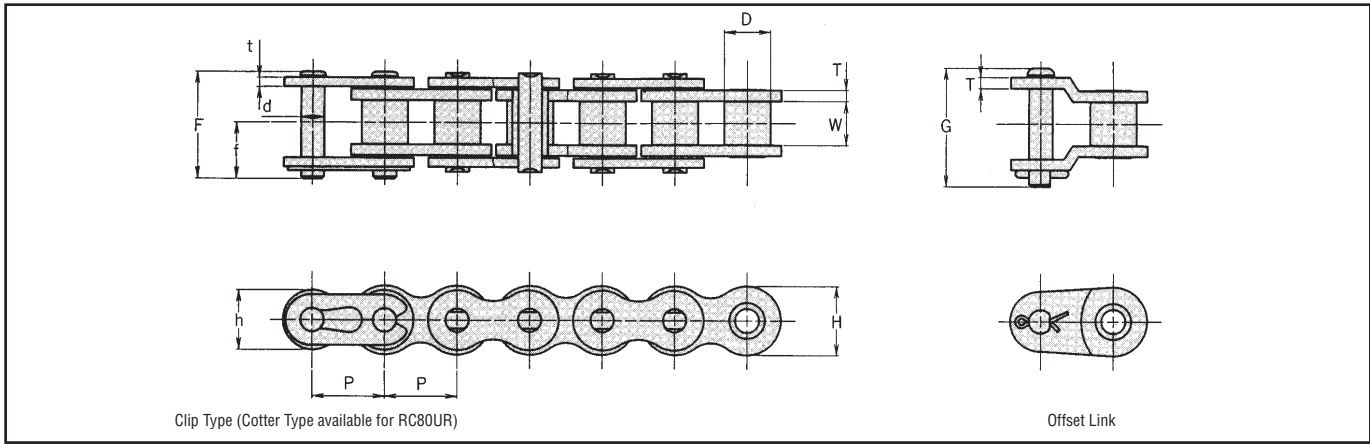

Dimensions

Unit (inch)

Chain No.	Pitch P	Roller Link Width W	Roller Dia. D	Pin				Plate				Avg. Tensile Strength lbs.	Max. Allowable Load lbs.	Approx. Weight (lbs/FT)
				d	F	f	G	T	t	H	h			
RC40UR, URN, URF	0.500	0.313	0.312	0.156	0.748	0.409	0.807	0.079	0.059	0.472	0.409	4004	836	0.463
RC50UR, URN, URF	0.625	0.375	0.400	0.200	0.898	0.484	0.984	0.094	0.079	0.591	0.591	6710	1540	0.731
RC60UR, URN, URF	0.750	0.500	0.469	0.235	1.138	0.622	1.303	0.126	0.094	0.713	0.713	9460	2090	1.147
RC80UR, URN, URF	1.000	0.623	0.625	0.313	1.461	0.787	1.563	0.157	0.126	0.945	0.945	17270	3300	1.878

Note) UR: Sintered Bushing Roller Chain URN: Rustless Sintered Bushing Roller Chain

Design of chain transmission

In a sintered bushing roller chain, to compensate for the strength lowered by the use of sintered bushing, the inner plates are thicker than those of a standard roller chain, and the pins are longer.

For selecting a proper sintered bushing roller chain, refer to "General selection" (P. 64). Use the tables for sintered bushing roller chain which specify the maximum horsepower speed selection". In the tables of dimensions, the "maximum allowable load", only the tensile tension is taken into account, and the shock load is not considered.

Connecting links and offset links

For sintered bushing roller chain, clip type connecting links are used for 60 or smaller, and cotter type connecting link, for 80 or larger. Offset links, are available. In either case, please specify "For a sintered bushing roller chain". In the table of maximum horsepower ratings, the strength of the connecting links and offset links are taken into account.

Sintered Bushing Roller Chain Max. Horsepower Ratings (RC40UR, RC50UR)

TRANSMISSION
ROLLER CHAIN

ULTIMATE LIFE
CHAIN SERIES

RC40UR

Unit (hp)

N.T	Revolutions per minute - Small Sprocket (rpm)																			
	10	20	30	50	70	90	100	150	200	300	400	500	600	700	800	900	1000	1100	1200	1300
9	0.05	0.09	0.13	0.21	0.29	0.36	0.40	0.58	0.75	1.09	1.41	1.72	2.02	2.33	2.63	2.92	3.22	3.04	2.67	2.36
10	0.05	0.11	0.15	0.24	0.34	0.42	0.46	0.66	0.84	1.22	1.58	1.93	2.28	2.61	2.95	3.27	3.61	3.55		
11	0.07	0.12	0.17	0.27	0.36	0.46	0.50	0.72	0.94	1.35	1.74	2.14	2.52	2.90	3.27	3.63	3.99			
12	0.07	0.13	0.19	0.29	0.40	0.50	0.55	0.79	1.03	1.49	1.92	2.35	2.76	3.18	3.58	3.98				
13	0.08	0.15	0.20	0.32	0.44	0.55	0.60	0.87	1.13	1.62	2.09	2.56	3.02	3.47	3.91	4.34				
14	0.08	0.15	0.21	0.35	0.47	0.59	0.66	0.94	1.22	1.76	2.27	2.77	3.27	3.75	4.24					
15	0.09	0.16	0.24	0.38	0.51	0.64	0.70	1.01	1.31	1.89	2.44	2.99	3.53	4.05						
16	0.09	0.17	0.25	0.40	0.55	0.68	0.75	1.09	1.41	2.02	2.63	3.20	3.78	4.34						
17	0.11	0.19	0.27	0.43	0.59	0.74	0.80	1.15	1.50	2.16	2.80	3.42	4.03							
18	0.11	0.20	0.29	0.46	0.62	0.78	0.86	1.23	1.60	2.29	2.98	3.65	4.29							
19	0.12	0.21	0.31	0.48	0.66	0.83	0.91	1.30	1.69	2.44	3.15	3.86	4.54							
20	0.12	0.23	0.32	0.51	0.70	0.87	0.95	1.38	1.78	2.57	3.34	4.08								
21	0.12	0.24	0.34	0.54	0.74	0.92	1.01	1.46	1.89	2.72	3.51	4.30								
22	0.13	0.25	0.36	0.56	0.76	0.97	1.06	1.53	1.98	2.86	3.70	4.52								
23	0.13	0.27	0.38	0.60	0.80	1.02	1.11	1.61	2.08	2.99	3.87	4.75								
24	0.15	0.27	0.39	0.63	0.84	1.06	1.17	1.68	2.17	3.14	4.06									
25	0.15	0.28	0.42	0.66	0.88	1.11	1.22	1.76	2.28	3.27	4.25									
28	0.17	0.32	0.47	0.74	1.01	1.25	1.38	1.98	2.57	3.70	4.80									
30	0.19	0.35	0.50	0.79	1.07	1.35	1.49	2.14	2.77	3.99										
32	0.20	0.38	0.54	0.86	1.15	1.45	1.60	2.29	2.98	4.28										
35	0.21	0.42	0.59	0.94	1.27	1.60	1.76	2.52	3.27	4.72										
40	0.25	0.47	0.68	1.09	1.47	1.84	2.02	2.92	3.78											

RC50UR

Unit (hp)

N.T	Revolutions per minute - Small Sprocket (rpm)																			
	10	20	30	50	70	90	100	150	200	300	400	500	600	700	800	900	1000	1100	1200	1300
9	0.12	0.23	0.32	0.52	0.71	0.88	0.97	1.39	1.81	2.21	2.61	2.99	3.38	3.75	4.13	4.87	5.59	5.86	4.91	4.18
10	0.13	0.25	0.36	0.58	0.79	0.99	1.09	1.57	2.02	2.48	2.92	3.35	3.78	4.21	4.62	5.46	6.26	6.85	5.75	
11	0.15	0.28	0.40	0.64	0.87	1.10	1.21	1.73	2.25	2.75	3.24	3.73	4.20	4.66	5.13	6.05	6.94	7.83		
12	0.16	0.31	0.44	0.71	0.97	1.21	1.33	1.90	2.47	3.02	3.55	4.09	4.61	5.12	5.63	6.64	7.63			
13	0.19	0.34	0.48	0.78	1.05	1.31	1.45	2.08	2.69	3.30	3.87	4.45	5.03	5.59	6.14	7.24	8.31			
14	0.20	0.36	0.52	0.84	1.14	1.42	1.57	2.25	2.92	3.57	4.21	4.83	5.44	6.06	6.65	7.84				
15	0.21	0.40	0.58	0.90	1.22	1.53	1.69	2.43	3.14	3.85	4.53	5.20	5.87	6.53	7.17	8.45				
16	0.23	0.43	0.62	0.97	1.31	1.65	1.81	2.60	3.36	4.12	4.85	5.58	6.29	7.00	7.69					
17	0.24	0.46	0.66	1.03	1.39	1.76	1.93	2.77	3.59	4.40	5.19	5.95	6.72	7.47	8.20					
18	0.25	0.48	0.70	1.10	1.49	1.86	2.05	2.95	3.83	4.68	5.51	6.33	7.14	7.94	8.73					
19	0.27	0.51	0.74	1.17	1.58	1.98	2.17	3.14	4.06	4.96	5.84	6.72	7.57	8.42						
20	0.29	0.54	0.78	1.23	1.66	2.09	2.29	3.31	4.29	5.24	6.18	7.09	8.00	8.90						
21	0.31	0.56	0.82	1.30	1.76	2.20	2.43	3.49	4.52	5.52	6.51	7.48	8.43							
22	0.32	0.60	0.86	1.37	1.85	2.32	2.55	3.67	4.76	5.82	6.85	7.87	8.87							
23	0.34	0.63	0.90	1.43	1.94	2.43	2.67	3.85	4.99	6.10	7.18	8.26	9.30							
24	0.35	0.66	0.95	1.50	2.02	2.55	2.80	4.03	5.23	6.38	7.52	8.65								
25	0.36	0.68	0.99	1.57	2.12	2.65	2.92	4.21	5.46	6.68	7.86	9.03								
28	0.42	0.78	1.11	1.77	2.40	3.00	3.31	4.76	6.17	7.53	8.89									
30	0.44	0.83	1.21	1.90	2.59	3.24	3.57	5.13	6.65	8.12	9.57									
32	0.48	0.90	1.29	2.05	2.77	3.47	3.82	5.50	7.13	8.71										
35	0.54	0.99	1.42	2.25	3.06	3.82	4.21	6.06	7.86	9.60										
40	0.62	1.14	1.65	2.60	3.53	4.42	4.85	7.00	9.06											

Ref: Horsepower Rating table of sintered bushing chains is made on the basis of approx. 1000 hour endurance time.

Sintered Bushing Roller Chain Max. Horsepower Ratings (RC60UR, RC80UR)

RC60UR

Unit (hp)

N.T	Revolutions per minute - Small Sprocket (rpm)																			
	10	20	30	50	70	90	100	150	200	250	300	350	400	450	500	550	600	650	700	800
9	0.19	0.36	0.51	0.82	1.10	1.38	1.51	2.18	2.83	3.46	4.08	4.68	5.28	5.87	6.45	7.02	7.60	8.18	8.27	6.77
10	0.21	0.40	0.58	0.91	1.23	1.54	1.70	2.45	3.16	3.87	4.57	5.24	5.91	6.58	7.23	7.88	8.53	9.16	9.69	
11	0.24	0.44	0.64	1.01	1.37	1.72	1.88	2.71	3.51	4.29	5.07	5.82	6.55	7.29	8.02	8.73	9.44	10.1	10.8	
12	0.25	0.48	0.70	1.11	1.50	1.88	2.06	2.98	3.86	4.72	5.56	6.38	7.20	8.00	8.81	9.60	10.4	11.2		
13	0.28	0.54	0.76	1.21	1.64	2.05	2.25	3.24	4.21	5.15	6.06	6.96	7.86	8.73	9.60	10.5	11.3			
14	0.31	0.58	0.83	1.31	1.77	2.23	2.44	3.51	4.56	5.58	6.57	7.55	8.51	9.46	10.4	11.33				
15	0.34	0.62	0.88	1.41	1.90	2.40	2.63	3.79	4.91	6.01	7.08	8.12	9.17	10.2	11.2					
16	0.36	0.66	0.95	1.51	2.05	2.56	2.83	4.06	5.27	6.43	7.59	8.71	9.83	10.9						
17	0.38	0.71	1.02	1.61	2.18	2.73	3.02	4.34	5.62	6.88	8.10	9.30	10.5	11.7						
18	0.40	0.75	1.09	1.72	2.32	2.91	3.20	4.61	5.98	7.31	8.62	9.89	11.2							
19	0.43	0.80	1.15	1.82	2.47	3.10	3.39	4.89	6.34	7.75	9.13	10.5	11.8							
20	0.46	0.84	1.22	1.93	2.60	3.27	3.59	5.17	6.70	8.19	9.65	11.1								
21	0.48	0.88	1.29	2.02	2.75	3.45	3.78	5.46	7.06	8.63	10.2	11.7								
22	0.50	0.94	1.34	2.13	2.88	3.62	3.98	5.74	7.43	9.08	10.7	12.3								
23	0.52	0.98	1.41	2.24	3.03	3.79	4.18	6.02	7.79	9.53	11.2									
24	0.55	1.03	1.47	2.35	3.18	3.98	4.37	6.30	8.16	9.97	11.8									
25	0.58	1.07	1.54	2.45	3.31	4.16	4.57	6.58	8.53	10.4	12.3									
28	0.64	1.22	1.74	2.76	3.74	4.69	5.16	7.44	9.64	11.8										
30	0.70	1.31	1.88	2.98	4.03	5.05	5.56	8.02	10.4	12.7										
32	0.75	1.41	2.02	3.19	4.33	5.43	5.97	8.59	11.1											
35	0.83	1.54	2.23	3.53	4.77	5.98	6.57	9.46	12.3											
40	0.95	1.78	2.57	4.06	5.51	6.90	7.59	10.9												

TRANSMISSION ROLLER CHAIN

ULTIMATE LIFE CHAIN SERIES

RC80UR

Unit (hp)

N.T	Revolutions per minute - Small Sprocket (rpm)																					
	10	20	30	40	50	60	70	80	90	100	120	140	160	180	200	250	300	400	150	500	550	600
9	0.47	0.86	1.25	1.61	1.97	2.32	2.67	3.00	3.34	3.67	4.33	4.97	5.62	6.23	6.86	8.38	9.88	12.8	14.2	15.6	15.0	13.1
10	0.52	0.97	1.39	1.81	2.21	2.60	2.99	3.36	3.74	4.12	4.85	5.58	6.29	6.98	7.68	9.40	11.1	14.3	15.9	17.5	17.5	
11	0.58	1.07	1.54	2.00	2.44	2.88	3.31	3.74	4.16	4.57	5.38	6.18	6.97	7.75	8.51	10.4	12.3	15.9	17.7	19.4		
12	0.63	1.18	1.70	2.20	2.68	3.16	3.63	4.10	4.56	5.01	5.91	6.78	7.65	8.51	9.36	11.4	13.5	17.5	19.4			
13	0.68	1.29	1.85	2.40	2.94	3.46	3.97	4.48	4.97	5.47	6.45	7.40	8.35	9.28	10.2	12.5	14.7	19.0	21.2			
14	0.75	1.39	2.01	2.60	3.18	3.74	4.30	4.84	5.39	5.92	6.98	8.02	9.03	10.1	11.1	13.5	15.9	20.6				
15	0.80	1.50	2.16	2.80	3.42	4.03	4.62	5.21	5.80	6.38	7.52	8.63	9.75	10.8	11.9	14.6	17.2					
16	0.86	1.61	2.32	3.00	3.67	4.32	4.96	5.60	6.22	6.84	8.06	9.26	10.4	11.6	12.8	15.6	18.4					
17	0.92	1.72	2.47	3.20	3.91	4.61	5.29	5.98	6.65	7.31	8.61	9.89	11.2	12.4	13.6	16.7	19.6					
18	0.98	1.82	2.63	3.40	4.17	4.91	5.63	6.35	7.06	7.77	9.16	10.5	11.9	13.2	14.5	17.7	20.9					
19	1.03	1.93	2.79	3.61	4.41	5.20	5.98	6.74	7.49	8.23	9.71	11.2	12.6	14.0	15.4	18.8	22.1					
20	1.10	2.05	2.95	3.82	4.66	5.50	6.31	7.12	7.92	8.70	10.3	11.8	13.3	14.8	16.2	19.9						
21	1.15	2.16	3.11	4.02	4.92	5.79	6.66	7.51	8.35	9.18	10.8	12.4	14.0	15.6	17.1	20.9						
22	1.22	2.27	3.27	4.24	5.17	6.10	7.00	7.90	8.78	9.65	11.4	13.1	14.7	16.4	18.0	22.0						
23	1.27	2.37	3.43	4.44	5.43	6.39	7.35	8.28	9.21	10.1	11.9	13.7	15.5	17.2	18.9	23.1						
24	1.34	2.49	3.59	4.65	5.68	6.69	7.69	8.67	9.64	10.6	12.5	14.4	16.2	18.0	19.8							
25	1.39	2.60	3.75	4.85	5.94	7.00	8.04	9.06	10.1	11.1	13.1	15.0	16.9	18.8	20.7							
28	1.58	2.94	4.24	5.48	6.72	7.91	9.09	10.2	11.4	12.5	14.8	16.9	19.1	21.2	23.4							
30	1.70	3.16	4.57	5.91	7.23	8.51	9.79	11.0	12.3	13.5	15.9	18.3	20.6	22.9								
32	1.82	3.39	4.89	6.34	7.75	9.13	10.5	11.8	13.2	14.5	17.0	19.6	22.1	24.5								
35	2.01	3.74	5.39	6.98	8.54	10.1	11.6	13.0	14.5	15.9	18.8	21.6	24.3									
40	2.32	4.33	6.23	8.07	9.87	11.6	13.4	15.1	16.7	18.4	21.7	24.9										

Ref : Horsepower Rating table of sintered bushing chains is made on the basis of approx. 1000 hour endurance test.

2-4 DID Environment Resistant Chain Series

2-4-1 Selection of Environment Resistant Chain Series

The DID general application chain include the Environment Resistant Chain Series. This series is intended for use in special environments, such as outdoor use with exposure to rain, use on a ship, exposure to a salty environment, and use

in a place where a chemical material is dispersed. The Environment Resistant Chain Series includes the following four kinds.

- Rustless Chain Brilliant, clean, shiny nickel plating.
- Hi-Guard Chain..... Excellent in corrosion resistance without sacrificing strength
- Low temperature chain For use in cold storage, warehouse and conveyors.
- Stainless steel chain..... Corrosion resistant and heat resistance for food processing, water treatment, chemical, etc.

Design of chain transmission

An environment resistant chain is equivalent to ANSI standard roller chain in strength, except for the stainless steel chain. Therefore, for selection of proper environment resistant chain call customer service at Daido Corporation of America.

Connecting links and offset links

For all kinds of environment resistant chain, slip fit (clip type) connecting links are available for 60 or smaller, and slip fit (cotter type) connecting link for 80 or larger. 2P Offset Link is available for RC25 and RC35, and Half Link and 2P Offset Link, for the other sizes. However, for low temperature chain, no offset link is available. For stainless steel chain, 2P Offset Link is not available.

Sprockets

Since the dimensions of these chain are the same as those of standard roller chain, standard sprockets can be used.

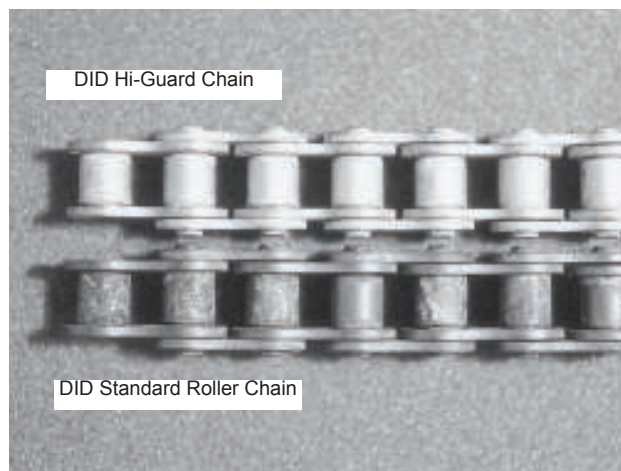

Surface conditions after corrosion test

Comparison Chart of Environment Resistant Chain Series (please refer to pg. 43 for Chain No.)

Series	Mark	Strength		Moisture Resistance Performance (without additional lubrication)		Corrosion Resistance Performance				
		Max. Allowable Load Ratio	Chain Selecting Method	Initial Lubricant Applied		Based on CASS test	Exposed to water or salt water	Alkaline Resistance Performance	Acid Resistance Performance	Heat Resistance Performance
Standard Roller Chain	—	100%	Max. Horsepower Ratings or Slow-Speed Selection	Rust Prevention Oil	inferior	inferior	not recommended	normal	not recommended	-10°C~80°C (14°F~176°F)
				Grease	normal	normal (note)				
Rustless Chain	N	100%		Rust Prevention Oil	inferior	good (note)	good	excellent	Applicable in light acid	Layer withstands up to 250°C (482°F)
				Grease	normal	very good				
Hi-Guard Chain	E	100%		Rust Prevention Oil	inferior	excellent	excellent	normal	not recommended	Layer withstands up to 250°C (482°F)
				Grease	normal					
Low Temperature Chain	TK	100%	Special Grease	normal	normal	not recommended	normal	not recommended	-40°C~80°C (40°F~176°F)	
Stainless Chain	SS	10%	Slow-Speed Selection	Stainless Chain is inferior to others in wear resistance performance. Chain tension must be within allowable range.		Same as Stainless Steel				
	SSK	15%								

Note: Even rustless chain, 25N, 35N and 41N should be read from "good" to "normal" and "excellent" to "good" because of the thin plating layer.

2-4-2 **D.I.D.** Rustless Chain (N)

D.I.D Rustless Chain is an outstanding corrosion resistant chain because its surface is nickel plated. In applications where chain is exposed to the possibility of hydrogen brittleness caused by acid vapor or salty environment, nickel plating delays the corrosive effect on the chain.

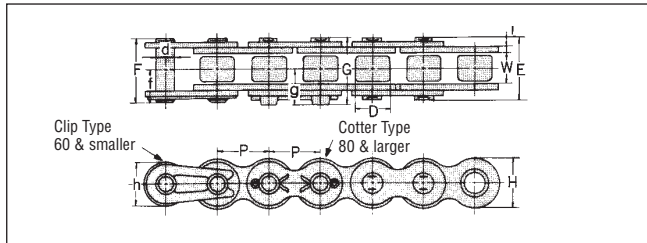

Result of CASS Test

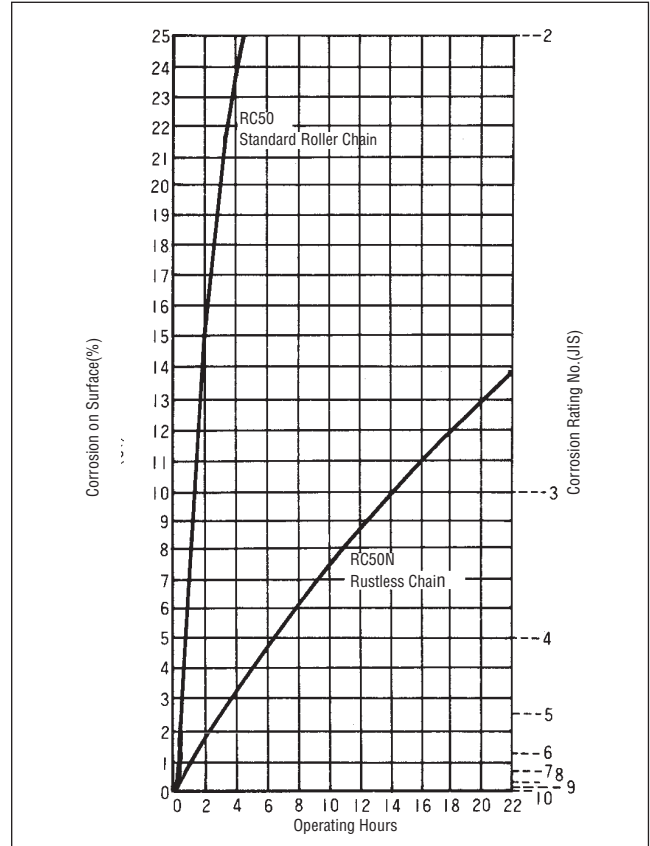

TRANSMISSION
ROLLER CHAIN

ENVIRONMENT
RESISTANT
CHAIN SERIES

Dimensions

Chain No.	Pitch P	Roller Link Width W	Roller Dia. D	Pin					Transverse Pitch C	Plate			DID Avg. Tensile Strength lbs	DID Max. Allowable Load lbs	Approx. Weight (lbs/FT)
				d	E	G	e	g		T	H	h			
*RC25N	0.250	0.125	0.130	0.091	0.307	0.335	—	0.185	—	0.028	0.232	0.205	990	165	0.087
*RC35N	0.375	0.188	0.200	0.141	0.472	0.516	0.555	0.287	0.291	0.049	0.354	0.305	2530	484	0.215
RC41N	0.500	0.251	0.306	0.141	0.539	0.575	0.602	0.311	0.335	0.047	0.378	0.315	2420	528	0.262
RC40N	0.500	0.313	0.312	0.156	0.650	0.693	0.713	0.374	0.398	0.059	0.472	0.409	4290	836	0.422
RC50N	0.625	0.375	0.400	0.200	0.799	0.862	0.870	0.457	0.472	0.079	0.591	0.512	6930	1540	0.711
RC60N	0.750	0.500	0.469	0.235	1.000	1.059	1.098	0.563	0.594	0.094	0.713	0.614	9900	2090	0.966
RC80N	1.000	0.625	0.625	0.313	1.283	—	1.394	—	0.748	0.126	0.945	0.819	17600	3300	1.710
RC100N	1.250	0.750	0.750	0.376	1.555	—	1.673	—	0.894	0.157	1.177	1.024	26620	5060	2.541
RC120N	1.500	1.000	0.875	0.437	1.957	—	2.087	—	1.110	0.189	1.413	1.228	37400	6820	3.681
RC140N	1.750	1.000	1.000	0.500	2.110	—	2.299	—	1.248	0.220	1.650	1.429	48400	9020	4.768
RC160N	2.000	1.250	1.125	0.563	2.504	—	2.685	—	1.437	0.252	1.882	1.630	60500	11880	6.585

Note: Those marked with * indicated bush chain.

2-4-3 DID[®] Hi-Guard Chain (E)/Double Guard Chain (WE)

Hi-Guard chain is second in corrosion resistance performance, next to a stainless steel chain. A luster-less white protective film is formed on the surface of the chain by a special baking process. The Hi-Guard chain has excellent galvanic corrosion resistance and rust resistance. Since the film is heat-resistant up to 482°F, it protects the chain even in high temperature. The Hi-Guard chain has slightly lower tensile strength than standard chain, but it is equivalent in maximum allowable load and wear resistance. Stainless steel chain is lower in strength and wear resistance. For this reason, when sufficient corrosion resistance is required without sacrificing strength, Hi-Guard chain is recommended. Since the Hi-Guard film works as a sacrificial anode for the base chain, sufficient corrosion resistance can be expected even if the film peels.



Double Guard Chain (WE) has DID's unique two different coatings applied before assembly on the ANSI standard chain. It achieves approximately two times higher anti-corrosion performance than a Hi-Guard Chain in a salt water spray test. This chain also withstands light alkali and an acidic atmosphere and the best alternative of Stainless Steel Chain. The strength is the same as Hi-Guard Chain.

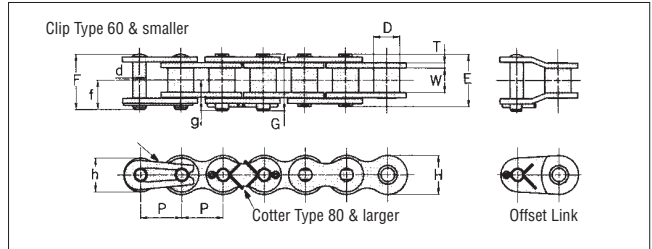

Dimensions

Chain No.	Pitch	Roller Link Width	Roller Dia.	Pin						Plate			DID Avg. Tensile Strength	DID Max. Allowable Load	Approx. Weight
				d	E	F	G	f	g	T	H	h			
* RC25-E	0.250	0.125	0.130	0.091	0.307	0.335	—	0.185	—	0.028	0.232	0.205	924	165	0.087
* RC35-E	0.375	0.188	0.200	0.141	0.472	0.516	—	0.287	—	0.049	0.354	0.305	2310	484	0.215
RC40-E/WE	0.500	0.313	0.312	0.156	0.650	0.693	—	0.374	—	0.059	0.472	0.409	3740	836	0.422
RC50-E/WE	0.625	0.375	0.400	0.200	0.799	0.862	—	0.457	—	0.079	0.591	0.512	6380	1540	0.711
RC60-E/WE	0.750	0.500	0.469	0.235	1.000	1.059	—	0.563	—	0.094	0.713	0.614	9020	2090	0.966
RC80-E/WE	1.000	0.625	0.625	0.313	1.283	—	1.394	—	0.748	0.126	0.945	0.819	16830	3300	1.710
RC100-E/WE	1.250	0.750	0.750	0.376	1.555	—	1.673	—	0.894	0.157	1.177	1.024	25300	5060	2.541
RC120-E/WE	1.500	1.000	0.875	0.437	1.957	—	2.087	—	1.110	0.189	1.413	1.228	35420	6820	3.681

Note: 1. Those marked with * indicate bush chains.
2. Please consult us when multiplex chain is desired

2-4-4 DID[®] Low Temperature Chain (TK)

Standard roller chain is likely to become brittle at low temperature and must be used at higher than 14°F. TK chain is unlikely to suffer from low temperature brittleness. TK chain can be used down to -40°F by setting the maximum allowable load as listed below.

The lubricating oil applied on the chain is a special low temperature oil.

Max. Allowable Load of TK Chain

Chain No.	Max. Allowable Load		Max. Allowable Load		Max. Allowable Load	
	80° ~ -10°C (176°F ~ 14°F)		-11°C ~ -30°C (12° F ~ -22° F)		-31°C ~ -40°C (-24° F ~ -40° F)	
RC40R-TK	3.72	836	2.54	572	2.15	484
RC50R-TK	6.86	1540	4.80	1078	3.92	880
RC60R-TK	9.31	2090	6.47	1452	5.39	1210
RC80R-TK	14.70	3300	10.29	2310	8.53	1914
RC100R-TK	22.55	5060	15.78	3542	13.04	2926
RC120R-TK	30.40	6820	21.28	4774	17.55	3938
RC140R-TK	40.20	9020	28.14	6314	23.24	5214
RC160R-TK	52.95	11880	37.06	8316	30.69	6886

Dimensions are same as those of standard roller chain (Please refer to P.14)

2-4-5 DID[®] Stainless Steel Chain (SS, SSK, SSLT)

DID Stainless Steel chain is available either as an SS chain with all of the components made of austenitic steel (SUS304, 18-8 stainless steel) or an SSK chain with pins, bushings and rollers made of quench-hardened stainless steel (SUS631) and with plates made of austenitic stainless steel (SUS304). An SS chain is the highest in corrosion resistance and heat resistance, and can be used in all chemical plants, food processing machines, water treatment machines, etc. However, since it is made of austenitic stainless steel, its tensile strength is less than 70 percent that of a standard roller chain. Furthermore, the maximum allowable tension is as low as 10 percent of standard roller chain. Therefore, these factors must be carefully examined when you select SS chain.

SSK chain is 1.5 times higher than SS chain in maximum allowable load. This is accomplished by improving the strengths of pins, bushings and rollers. Both SS & SSK are comparable in corrosion resistance.

Stainless Steel X-Ring chain (SSLT) with chemical resistant X-Ring and FDA/USDA approved lubricant is also available for up to 10 times longer wear life. See P. 47 for dimensions (Available in 40, 50, 60 and 80).

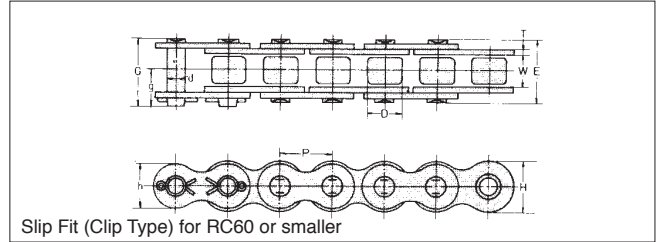

TRANSMISSION
ROLLER CHAIN

ENVIRONMENT
RESISTANT
CHAIN SERIES

Strength of SS Type

Chain No. DID	Max. Allowable Load	
	KN	lbs
*RC25SSR	0.12	29
*RC35SSR	0.26	59
RC40SSR	0.44	99
RC50SSR	0.69	154
RC60SSR	1.03	231
RC80SSR	1.77	396
RC100SSR	2.55	572
RC120SSR	3.82	858
RC140SSR	4.60	1034
RC160SSR	6.37	1430
RC200SSR	10.78	2420

Strength of SSK Type

Chain No. DID	Max. Allowable Load	
	KN	lbs
RC40SR	0.69	154
RC50SR	1.03	231
RC60SR	1.57	352
RC80SR	2.65	594
RC100SR	3.82	858

Dimensions

Unit (inch)

Chain No. DID	Pitch P	Roller Link Width W	Roller (Bush) Dia. D	Pin					Plate				Approx. Weight (lbs/FT)
				d	E	F	G	f	g	T	H	h	
*RC25SSR	0.250	0.122	0.130	0.091	0.299	0.335	—	0.185	—	0.030	0.236	0.205	0.087
*RC35SSR, 35SR	0.375	0.184	0.200	0.141	0.465	0.508	—	0.276	—	0.050	0.354	0.307	0.228
RC40SSR, 40SR	0.500	0.309	0.313	0.156	0.642	0.689	—	0.368	—	0.059	0.472	0.409	0.429
RC50SSR, 50SR	0.625	0.370	0.400	0.200	0.807	0.850	—	0.447	—	0.079	0.591	0.512	0.711
RC60SSR, 60SR	0.750	0.495	0.469	0.234	1.018	1.063	—	0.555	—	0.094	0.713	0.614	1.046
RC80SSR, 80SR	1.000	0.620	0.625	0.312	1.280	—	1.366	—	0.726	0.126	0.949	0.819	1.757
RC100SSR, 100SR	1.250	0.744	0.750	0.375	1.587	—	1.667	—	0.874	0.157	1.185	1.024	2.769
RC120SSR	1.500	1.000	0.875	0.435	2.071	—	2.185	—	1.146	0.197	1.413	1.228	4.111
RC140SSR	1.750	1.000	1.000	0.498	2.272	—	2.437	—	1.295	0.236	1.650	1.429	5.304
RC160SSR	2.000	1.250	1.125	0.560	2.531	—	2.697	—	1.417	0.236	1.882	1.630	7.282
RC200SSR	2.500	1.500	1.562	0.776	3.122	—	3.398	—	1.827	0.315	2.362	2.047	11.091

Note: Those marked with * indicate bush chain.

2-5 DID[®] Low Noise Chain Series

The demand for and lower equipment noise in the working significant environment is growing. The chain greatly enhanced in silencing effect to meet such demands is the DID Low Noise Chain Series.

In printing, packaging, engineering, parking and various conveyors, low noise chain provides a silencing effect.

2-5-1 DID[®] Super Low Noise Chain

A "two piece roller structure" achieves a significant noise reduction effect. When the chain is engaged with a sprocket, the audible shock is reduced by the elastic deformation of rollers, made of special elastomer, achieving a silencing effect as much as 10 DB. When the chain is used for conveying, the sliding noise between the rails and the rollers is effectively reduced. Available sizes are RC40SLN to 80SLN.

Design of chain transmission

For selecting a proper low noise chain, refer to "general selection". Also refer to the tables of maximum horsepower ratings for SLN chain (P.57 & 58).

For SLN chain, "Slow-speed selection" cannot be used. The maximum allowable load in the tables of dimensions considers only the tensile strength of the chain, and neglects roller

Connecting links and offset links

For low noise connecting links, the standard chain can be used. Both Half link and 2P Offset link are available. Please specify "for SLN chain".

Sprockets

Standard sprockets can be used.

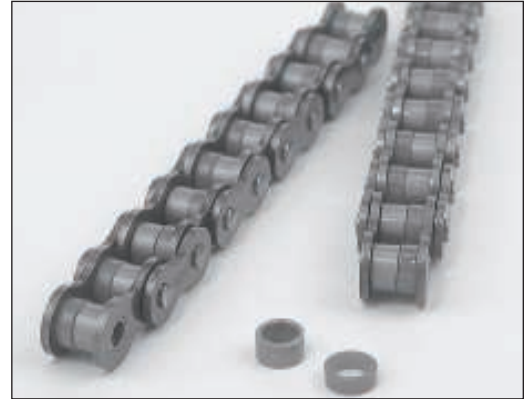

Note: Color of elastomer roller may be changed for the required specification.

Noise Reduction Efficiency Chart

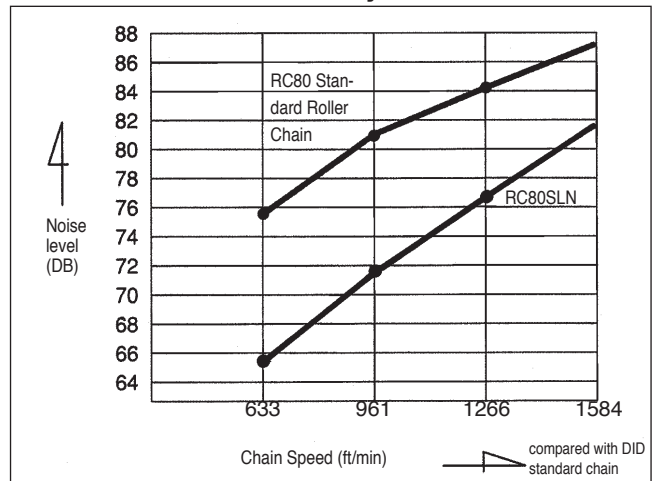

Max. Allowable Load in Roller

Unit: N(lbs) /pc

Chain No.	Allowable Load
RC40SLN	78 18
RC50SLN	117 26
RC60SLN	196 44
RC80SLN	313 70

* 1 Roller (1pc of steel rollers and 1pc of rubber roller)

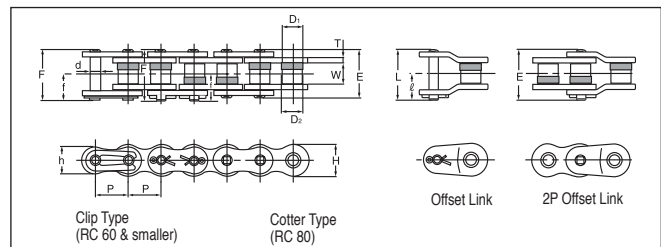
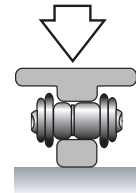

Dimensions

Chain No. DID	Pitch P	Roller Link Width W	Roller Dia.		Pin							Plate			DID Avg. Tensile Strength lbs	DID Max. Allowable Load lbs	Approx. Weight (lbs/FT)
			D ₁	D ₂	d	E	F	f	L	I	T	H	h				
RC40SLN	0.500	0.313	0.304	0.321	0.156	0.650	0.693	0.374	0.7600	.417	0.059	0.472	0.409	4290	836	0.396	
RC50SLN	0.625	0.375	0.388	0.409	0.200	0.799	0.862	0.457	0.9090	.476	0.079	0.591	0.512	6930	1540	0.657	
RC60SLN	0.750	0.500	0.455	0.478	0.235	1.000	1.059	0.563	1.1810	.618	0.094	0.713	0.614	9900	2090	0.959	
RC80SLN	1.000	0.625	0.604	0.634	0.313	1.291	1.390	0.748	1.4610	.768	0.126	0.945	0.819	17600	3300	1.583	

Note: Above Max. allowable load is determined only by link plates and pin, and roller is not considered for the chain.

Super Low-Noise Chain Max. Horsepower Ratings (RC40SLN, RC50SLN)

RC40SLN

Unit (HP)

N.T	Revolutions per minute - Small Sprocket (rpm)																			
	10	20	30	50	70	100	150	200	300	400	500	600	700	800	900	1000	1100	1200	1300	1500
11	0.07	0.12	0.17	0.27	0.36	0.50	0.70	0.67	0.64	0.63	0.62	0.60	0.59	0.59	0.58	0.58	0.56	0.56	0.56	0.55
12	0.07	0.13	0.19	0.29	0.40	0.55	0.79	0.76	0.74	0.71	0.70	0.68	0.68	0.67	0.66	0.66	0.64	0.64	0.63	
13	0.08	0.15	0.20	0.32	0.44	0.60	0.87	0.87	0.83	0.80	0.79	0.78	0.76	0.75	0.75	0.74	0.72	0.72		
14	0.08	0.15	0.21	0.35	0.47	0.66	0.94	0.97	0.92	0.90	0.88	0.87	0.86	0.84	0.83	0.82	0.82			
15	0.09	0.16	0.24	0.38	0.51	0.70	1.01	1.07	1.03	1.01	0.98	0.97	0.95	0.94	0.92	0.91	0.90			
16	0.09	0.17	0.25	0.40	0.55	0.75	1.09	1.18	1.14	1.10	1.07	1.06	1.05	1.03	1.02	1.01				
17	0.11	0.19	0.27	0.43	0.59	0.80	1.15	1.30	1.25	1.21	1.18	1.15	1.14	1.13	1.11					
18	0.11	0.20	0.29	0.46	0.62	0.86	1.23	1.41	1.35	1.31	1.29	1.26	1.25	1.23	1.21					
19	0.12	0.21	0.31	0.48	0.66	0.91	1.30	1.53	1.47	1.42	1.39	1.37	1.35	1.33						
20	0.12	0.23	0.32	0.51	0.70	0.95	1.38	1.65	1.58	1.54	1.50	1.47	1.46	1.43						
21	0.12	0.24	0.34	0.54	0.74	1.01	1.46	1.78	1.70	1.66	1.62	1.60	1.57							
22	0.13	0.25	0.36	0.56	0.76	1.06	1.53	1.90	1.82	1.78	1.74	1.70	1.68							
23	0.13	0.27	0.38	0.60	0.80	1.11	1.61	2.04	1.96	1.90	1.86	1.82	1.80							
24	0.15	0.27	0.39	0.63	0.84	1.17	1.68	2.17	2.08	2.02	1.98	1.94								
25	0.15	0.28	0.42	0.66	0.88	1.22	1.76	2.28	2.21	2.16	2.10	2.06								
28	0.17	0.32	0.47	0.74	1.01	1.38	1.98	2.57	2.63	2.55	2.49									
30	0.19	0.35	0.50	0.79	1.07	1.49	2.14	2.77	2.91	2.83	2.76									
32	0.20	0.38	0.54	0.86	1.15	1.60	2.29	2.98	3.20	3.12	3.04									
35	0.21	0.42	0.59	0.94	1.27	1.76	2.52	3.27	3.67	3.57										
40	0.25	0.47	0.68	1.09	1.47	2.02	2.92	3.78	4.49	4.36										
45	0.29	0.54	0.78	1.23	1.66	2.31	3.31	4.29	5.35											
50	0.32	0.60	0.87	1.38	1.86	2.57	3.71	4.81	6.27											
55	0.36	0.67	0.97	1.53	2.08	2.86	4.12	5.34	7.23											
60	0.39	0.74	1.06	1.68	2.28	3.14	4.52	5.86												

TRANSMISSION
ROLLER CHAIN

LOW NOISE
CHAIN SERIES

RC50SLN

Unit (HP)

N.T	Revolutions per minute - Small Sprocket (rpm)																			
	10	20	30	50	70	100	150	200	250	300	350	400	450	500	600	700	800	900	1000	1200
11	0.15	0.28	0.40	0.64	0.87	1.21	1.73	1.76	1.72	1.69	1.66	1.64	1.62	1.61	1.57	1.55	1.53	1.51	1.50	1.47
12	0.16	0.31	0.44	0.71	0.97	1.33	1.90	2.00	1.96	1.92	1.89	1.86	1.85	1.82	1.80	1.77	1.74	1.73	1.70	
13	0.19	0.34	0.48	0.78	1.05	1.45	2.08	2.25	2.21	2.17	2.13	2.10	2.08	2.06	2.02	2.00	1.97	1.94	1.92	
14	0.20	0.36	0.52	0.84	1.14	1.57	2.25	2.52	2.47	2.43	2.39	2.36	2.33	2.31	2.27	2.23	2.20	2.17		
15	0.21	0.40	0.58	0.90	1.22	1.69	2.43	2.80	2.73	2.68	2.64	2.61	2.59	2.56	2.51	2.47	2.44			
16	0.23	0.43	0.62	0.97	1.31	1.81	2.60	3.08	3.02	2.96	2.91	2.88	2.84	2.82	2.76	2.72	2.68			
17	0.24	0.46	0.66	1.03	1.39	1.93	2.77	3.38	3.30	3.24	3.19	3.15	3.11	3.08	3.03	2.98				
18	0.25	0.48	0.70	1.10	1.49	2.05	2.95	3.67	3.59	3.54	3.49	3.43	3.39	3.35	3.30	3.24				
19	0.27	0.51	0.74	1.17	1.58	2.17	3.14	3.99	3.90	3.83	3.77	3.73	3.67	3.65	3.58					
20	0.29	0.54	0.78	1.23	1.66	2.29	3.31	4.29	4.21	4.14	4.08	4.02	3.97	3.93	3.86					
21	0.31	0.56	0.82	1.30	1.76	2.43	3.49	4.52	4.53	4.45	4.38	4.33	4.28	4.24	4.16					
22	0.32	0.60	0.86	1.37	1.85	2.55	3.67	4.76	4.87	4.77	4.71	4.64	4.58	4.53	4.45					
23	0.34	0.63	0.90	1.43	1.94	2.67	3.85	4.99	5.20	5.11	5.03	4.96	4.91	4.85						
24	0.35	0.66	0.95	1.50	2.02	2.80	4.03	5.23	5.54	5.44	5.36	5.28	5.23	5.17						
25	0.36	0.68	0.99	1.57	2.12	2.92	4.21	5.46	5.88	5.78	5.70	5.62	5.55	5.50						
28	0.42	0.78	1.11	1.77	2.40	3.31	4.76	6.17	6.98	6.85	6.74	6.66	6.58							
30	0.44	0.83	1.21	1.90	2.59	3.57	5.13	6.65	7.75	7.60	7.48	7.39								
32	0.48	0.90	1.29	2.05	2.77	3.82	5.50	7.13	8.53	8.38	8.24	8.14								
35	0.54	0.99	1.42	2.25	3.06	4.21	6.06	7.86	9.60	9.58	9.44									
40	0.62	1.14	1.65	2.60	3.53	4.85	7.00	9.06	11.09	11.70										
45	0.70	1.30	1.86	2.96	4.01	5.52	7.95	10.29	12.59											
50	0.78	1.45	2.09	3.31	4.49	6.18	8.90	11.54	14.10											
55	0.86	1.61	2.32	3.67	4.97	6.85	9.87	12.79												
60	0.95	1.77	2.55	4.03	5.46	7.53	10.84	14.05												

Super Low-Noise Chain Max. Horsepower Ratings (RC60SLN, RC80SLN)

RC60SLN

Unit (HP)

Revolutions per minute - Small Sprocket (rpm)																			
10	20	30	50	70	100	150	200	250	300	350	400	450	500	550	600	700	800	900	1000
0.24	0.44	0.64	1.01	1.37	1.88	2.71	2.95	2.88	2.83	2.79	2.75	2.71	2.68	2.65	2.64	2.60	2.56	2.53	2.51
0.25	0.48	0.70	1.11	1.50	2.06	2.98	3.35	3.28	3.22	3.18	3.12	3.10	3.06	3.03	3.00	2.96	2.92	2.88	
0.28	0.54	0.76	1.21	1.64	2.25	3.24	3.78	3.70	3.63	3.58	3.53	3.49	3.45	3.42	3.39	3.34	3.30		
0.31	0.58	0.83	1.31	1.77	2.44	3.51	4.22	4.13	4.06	3.99	3.94	3.90	3.86	3.82	3.78	3.73			
0.34	0.62	0.88	1.41	1.90	2.63	3.79	4.69	4.58	4.50	4.44	4.37	4.32	4.28	4.24	4.20	4.13			
0.36	0.66	0.95	1.51	2.05	2.83	4.06	5.16	5.05	4.96	4.88	4.81	4.76	4.71	4.66	4.62				
0.38	0.71	1.02	1.61	2.18	3.02	4.34	5.62	5.54	5.43	5.35	5.28	5.21	5.16	5.11	5.07				
0.40	0.75	1.09	1.72	2.32	3.20	4.61	5.98	6.02	5.91	5.83	5.75	5.68	5.62	5.56	5.52				
0.43	0.80	1.15	1.82	2.47	3.39	4.89	6.34	6.53	6.42	6.31	6.23	6.17	6.10	6.05					
0.46	0.84	1.22	1.93	2.60	3.59	5.17	6.70	7.05	6.93	6.82	6.73	6.65	6.58	6.53					
0.48	0.88	1.29	2.02	2.75	3.78	5.46	7.06	7.59	7.45	7.35	7.24	7.16	7.08						
0.50	0.94	1.34	2.13	2.88	3.98	5.74	7.43	8.14	7.99	7.87	7.76	7.68	7.60						
0.52	0.98	1.41	2.24	3.03	4.18	6.02	7.79	8.70	8.55	8.42	8.30	8.20							
0.55	1.03	1.47	2.35	3.18	4.37	6.30	8.16	9.28	9.12	8.97	8.85	8.75							
0.58	1.07	1.54	2.45	3.31	4.57	6.58	8.53	9.87	9.68	9.53	9.41								
0.64	1.22	1.74	2.76	3.74	5.16	7.44	9.64	11.7	11.5	11.3									
0.70	1.31	1.88	2.98	4.03	5.56	8.02	10.4	12.7	12.7	12.5									
0.75	1.41	2.02	3.19	4.33	5.97	8.59	11.1	13.6	14.0										
0.83	1.54	2.23	3.53	4.77	6.57	9.46	12.3	15.0	16.0										
0.95	1.78	2.57	4.06	5.51	7.59	10.9	14.2	17.3											
1.09	2.02	2.92	4.62	6.26	8.62	12.4	16.1												
1.22	2.27	3.27	5.17	7.01	9.66	13.9	18.0												
1.35	2.52	3.62	5.74	7.76	10.7	15.4	20.0												
1.47	2.76	3.98	6.30	8.54	11.8	16.9													

RC80SLN

Unit (HP)

Revolutions per minute - Small Sprocket (rpm)																			
10	20	30	40	50	60	70	80	100	120	150	180	200	250	300	400	500	600	700	750
0.58	1.07	1.54	2.00	2.44	2.88	3.31	3.74	4.57	5.38	6.02	5.91	5.86	5.72	5.62	5.46	5.34	5.24	5.16	5.13
0.63	1.18	1.70	2.20	2.68	3.16	3.63	4.10	5.01	5.91	6.86	6.74	6.68	6.53	6.41	6.22	6.09	5.98		
0.68	1.29	1.85	2.40	2.94	3.46	3.97	4.48	5.47	6.45	7.73	7.60	7.52	7.36	7.23	7.02	6.86	6.74		
0.75	1.39	2.01	2.60	3.18	3.74	4.30	4.84	5.92	6.98	8.53	8.50	8.40	8.22	8.07	7.84	7.67			
0.80	1.50	2.16	2.80	3.42	4.03	4.62	5.21	6.38	7.52	9.20	9.42	9.32	9.12	8.95	8.70	8.51			
0.86	1.61	2.32	3.00	3.67	4.32	4.96	5.60	6.84	8.06	9.85	10.4	10.3	10.0	9.87	9.58	9.37			
0.92	1.72	2.47	3.20	3.91	4.61	5.29	5.98	7.31	8.61	10.5	11.4	11.2	11.0	10.8	10.5				
0.98	1.82	2.63	3.40	4.17	4.91	5.63	6.35	7.77	9.16	11.2	12.4	12.3	12.0	11.8	11.4				
1.03	1.93	2.79	3.61	4.41	5.20	5.98	6.74	8.23	9.71	11.9	13.4	13.3	13.0	12.8	12.4				
1.10	2.05	2.95	3.82	4.66	5.50	6.31	7.12	8.70	10.3	12.5	14.5	14.4	14.0	13.8	13.4				
1.15	2.16	3.11	4.02	4.92	5.79	6.66	7.51	9.18	10.8	13.2	15.6	15.4	15.1	14.8					
1.22	2.27	3.27	4.24	5.17	6.10	7.00	7.90	9.65	11.4	13.9	16.4	16.6	16.2	15.9					
1.27	2.37	3.43	4.44	5.43	6.39	7.35	8.28	10.1	11.9	14.6	17.2	17.7	17.3	17.0					
1.34	2.49	3.59	4.65	5.68	6.69	7.69	8.67	10.6	12.5	15.3	18.0	18.9	18.4	18.1					
1.39	2.60	3.75	4.85	5.94	7.00	8.04	9.06	11.1	13.1	16.0	18.8	20.1	19.6	19.3					
1.58	2.94	4.24	5.48	6.72	7.91	9.09	10.2	12.5	14.8	18.0	21.2	23.4	23.2						
1.70	3.16	4.57	5.91	7.23	8.51	9.79	11.0	13.5	15.9	19.4	22.9	25.2	25.8						
1.82	3.39	4.89	6.34	7.75	9.13	10.5	11.8	14.5	17.0	20.8	24.5	27.0	28.4						
2.01	3.74	5.39	6.98	8.54	10.1	11.6	13.0	15.9	18.8	22.9	27.0	29.7							
2.32	4.33	6.23	8.07	9.87	11.6	13.4	15.1	18.4	21.7	26.5	31.2	34.3							
2.63	4.91	7.08	9.17	11.2	13.2	15.2	17.1	20.9	24.6	30.1	35.5								
2.95	5.50	7.92	10.3	12.5	14.8	17.0	19.2	23.4	27.6	33.7									
3.27	6.10	8.78	11.4	13.9	16.4	18.8	21.2	26.0	30.6	37.4									
3.59	6.70	9.65	12.5	15.3	18.0	20.7	23.3	28.5	33.6										

TRANSMISSION ROLLER CHAIN
LOW NOISE CHAIN SERIES

3. DID Speciality Chain

In addition to general application chain, we also manufacture a number of specific application chain such as bicycle chain. Some specialty chain are applicable with standard sprockets and others are not. Various wear resistance measures taken for general application chain are not to apply for DID specialty chain. Specialty chain can be classified as follows:

- Bicycle chain
- Small pitch chain
- Engine mechanism chain
- Silent chain
- Motorcycle chain
- Agricultural chain
- Leaf chain
- British Standard roller chain

Bicycle Chain

Bicycle chain is a pronoun of the DID brand, as we were founded for the production of bicycle chain. Because of its consistent quality, they are used for many bicycles in Japan and other foreign countries. Recently, Hi-Guard chain (E) with an additional rust preventive treatment have been favorably received by users. The bicycle chain has been continuously examined and improved in performance, quality and specifications as evidenced by the availability of current product lines. As a result, they have dimensions and forms that make them the lightest and most compact chain in their pitch length. Presently, they are used in many applications other than bicycles, including vending and automatic change machines, agricultural implements, etc.

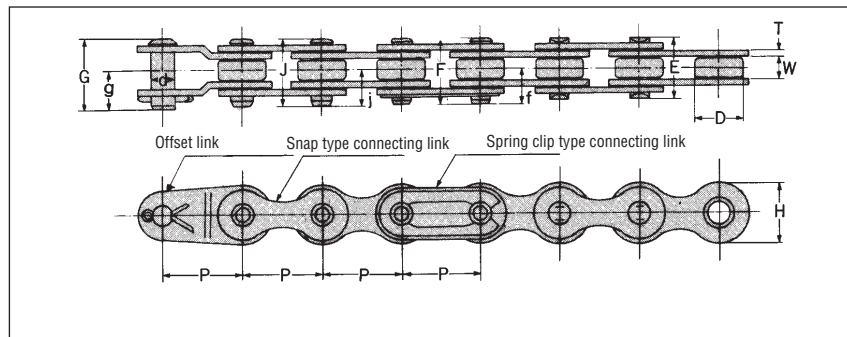

Dimensions

Chain No. DID	Pitch P	Roller Link Width W	Roller (Bush) Dia. D	Pin								Plate		DID Min. Tensile Strength lbs	DID Avg. Tensile Strength lbs	Approx. Weight (lbs/FT)
				d	E	F	G	J	f	g	l	H	T			
RC65	0.500	0.140	0.306	0.143	0.358	0.415	0.435	0.437	0.236	0.256	0.240	0.380	0.039	1826	2024	0.18
RC65-E	0.500	0.140	0.306	0.143	0.358	0.415	0.435	0.437	0.236	0.256	0.240	0.380	0.039	1826	2024	0.182

Note: (E) model are high Anti-tight joint performance type.

Small Pitch Chain

The smallest chain among ANSI roller chain is RC25 with 1/4" in pitch. In recent years, high technology machinery such as office equipment, medical machines and industrial robots demand smaller chain, and we are manufacturing RC15 with 3/16" pitch, and also RC15H which is the high-power version of RC15. They are precision manufactured chain with good wear resistance resulting from our stringent quality control.

RC15: A high precision micro-pitch bushing chain smaller than RC25 is designed for general mini-driving applications.



RC25: The smallest bushing chain among ANSI chain.

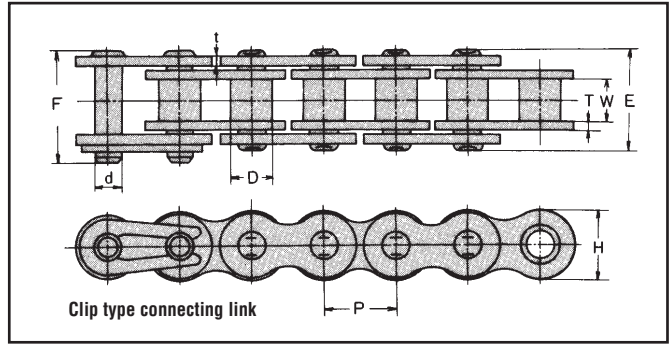

RC35: ANSI bushing chain recommended for small precision machines, etc. require greater strength.



Dimensions

Unit (inch)

Chain No. DID	Pitch P	Roller Link Width W	Roller (Bush) Dia. D	Pin			Plate			Bearing Area (cm ²)	DID Avg. Tensile Strength lbs	DID Max. Allowable Load lbs	Approx. Weight (lbs/FT)
				Dia d	Length		T	t	Width H				
					E	F							
RC15	0.188	0.094	0.098	0.064	0.246	0.272	0.024	0.024	0.169	0.009	594	110	0.060
RC15H	0.188	0.125	0.098	0.064	0.287	0.000	0.028	0.028	0.169	0.122	704	132	0.069
RC25	0.250	0.125	0.130	0.091	0.307	0.335	0.028	0.028	0.232	0.017	990	165	0.090
RC25H	0.250	0.125	0.130	0.091	0.354	0.372	0.039	0.039	0.232	0.019	1320	242	0.109
RC25T	0.250	0.125	0.130	0.091	0.315	0.335	0.028	0.028	0.232	0.017	990	165	0.090
RC35	0.375	0.188	0.200	0.141	0.472	0.512	0.049	0.049	0.354	0.041	2530	484	0.223
RC35T	0.375	0.188	0.200	0.141	0.472	0.512	0.049	0.049	0.354	0.041	2530	484	0.223

Selection of chain

Refer to the "Slow-speed selection"(P. 65). However, the chain operation speed can be very high, depending on the type of lubrication, as shown in the table on the right.

Connecting link and offset links

As for the connecting link, Slip fit clip type connecting links are available. However, since its strength is lower than that of the base chain, and since the spring clip can possibly come off in high speed operation, the use of clip type connecting links is not recommended. For high speed operation, riveted endless chain is recommended. Offset links are available for chain other than RC15 and RC15H, but their use is not recommended for the same reason as stated for the Slip fit clip type connecting links.

Operating Speed and Type of Lubrication

	Type A oil feeder, brush piling, dropping	Type B oil bath, oil splatter	Type C Pump oiling
RC15	656FT/min and under	3937FT/min and under	
RC15H			
RC25	492FT/min and under	3280FT/min and under	
RC25H			
RC25T			
RC35	360FT/min and under	2789FT/min and under	
RC35T			

Leaf Chain

Leaf chain consists of pins and plates only and generally have greater tensile strength than roller chain. Leaf chain is suitable for lifting and pulling applications

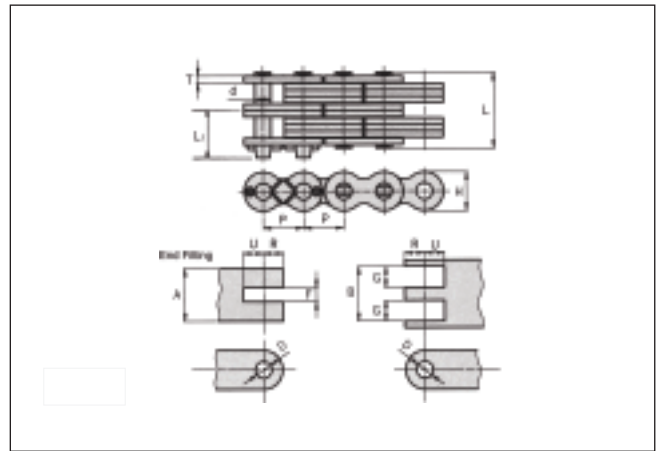
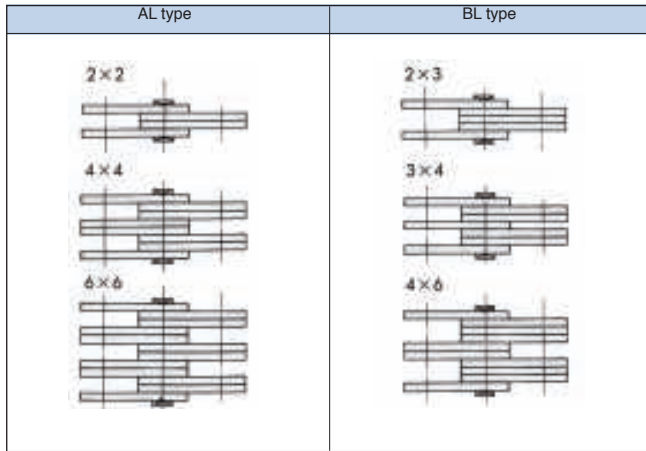

Dimensions

Unit (inch)

Chain	Pitch P	Plate		Pin		Min. Tensile Strength (lbs)	Max. Allowable Load (lbs)	Approx. Weight (lbs/ft)	End Fittings						
		H (Max)	T	d	L (Max)				b (Min.)	R	U (Min.)	F (Min.)	G (Min.)	A (Min.)	B
AL 422	0.50	0.41	0.06	0.16	0.33	3740	418	0.24	0.16	0.25	0.22	—	0.13	0.12	
AL 444					0.58	7480	792	0.48				0.13	0.13	0.36	
AL 466					0.82	11220	924	0.72				0.13	0.13	0.61	
AL 522	0.63	0.51	0.08	0.20	0.43	6160	682	0.42	0.20	0.31	0.28	—	0.17	0.16	
AL 544					0.74	12320	1430	0.82				0.17	0.17	0.48	
AL 566					1.08	18480	1518	1.23				0.17	0.17	0.81	
AL 588					1.41	24640	1936	1.63				0.17	0.17	1.15	
AL 622	0.75	0.61	0.09	0.23	0.51	8580	968	0.58	0.24	0.37	0.34	—	0.20	0.19	
AL 644					0.89	17160	1848	1.15				0.20	0.20	0.58	
AL 666					1.28	25740	2134	1.71				0.20	0.20	0.96	
AL 688					1.67	34320	2750	2.27				0.20	0.20	1.36	
AL 822	1.00	0.82	0.13	0.31	0.65	14520	1782	1.03	0.31	0.50	0.45	—	0.27	0.25	
AL 844					1.17	29744	3300	2.03				0.27	0.27	0.77	
AL 866					1.69	43560	3938	3.02				0.27	0.27	1.29	
AL 888					2.19	58080	5060	4.02				0.27	0.27	1.80	
AL 1022	1.25	1.02	0.16	0.38	0.81	22000	2904	1.68	0.38	0.62	0.56	—	0.33	0.31	
AL 1044					1.45	44000	5566	3.31				0.33	0.33	0.96	
AL 1066					2.10	66000	6424	4.94				0.33	0.33	1.61	
AL 1088					2.72	88000	8316	6.56				0.33	0.33	2.23	
AL 1222	1.50	1.22	0.19	0.44	0.96	31020	4202	2.33	0.44	0.75	0.67	—	0.39	0.38	
AL 1244					1.73	62040	8074	4.61				0.39	0.39	1.15	
AL 1266					2.49	93060	9284	6.87				0.39	0.39	1.91	
AL 1288					3.26	124080	11990	9.13				0.39	0.39	2.68	
AL 1444	1.75	1.42	0.22	0.50	2.03	80080	9724	5.79	0.50	0.87	0.78	0.46	0.46	1.34	
AL 1466					2.89	120120	11176	8.64				0.46	0.46	2.20	
AL 1644	2.00	1.61	0.25	0.56	2.29	103400	13002	7.60	0.57	1.00	0.89	0.52	0.52	1.53	
AL 1666					3.32	155100	14982	11.35				0.52	0.52	2.57	
BL 423	0.50	0.47	0.08	0.20	0.51	5280	990	0.48	0.20	0.25	0.25	—	0.25	0.24	
BL 434					0.68	8360	1122	0.66				0.08	0.17	0.41	
BL 446					0.93	11000	1320	0.76				0.17	0.25	0.66	
BL 466					1.08	16500	1386	1.13				0.17	0.17	0.81	
BL 523	0.63	0.59	0.09	0.23	0.60	8800	1672	0.77	0.24	0.31	0.31	—	0.30	0.29	
BL 534					0.79	13200	1914	1.06				0.10	0.20	0.48	
BL 544					0.89	17600	2024	1.21				0.20	0.20	0.58	
BL 546					1.08	17600	2222	1.51				0.20	0.30	0.77	
BL 566					1.28	26400	2332	1.80				0.20	0.20	0.97	
BL 623	0.75	0.71	0.13	0.31	0.78	15400	2442	1.15	0.31	0.37	0.37	—	0.39	0.39	
BL 634					1.04	23100	2794	1.60				0.13	0.26	0.65	
BL 644					1.17	30800	2970	1.81				0.26	0.26	0.78	
BL 646					1.44	30800	3234	2.25				0.26	0.39	1.05	
BL 666					1.69	46200	3410	2.69				0.26	0.26	1.30	
BL 823	1.00	0.95	0.16	0.38	0.97	23100	4444	1.90	0.38	0.50	0.50	—	0.49	0.48	
BL 834					1.29	34760	5060	2.64				0.17	0.33	0.80	
BL 844					1.45	46200	5368	3.01				0.33	0.33	0.96	
BL 846					1.77	46200	5896	3.74				0.33	0.49	1.28	
BL 866					2.10	67320	6182	4.48				0.33	0.33	1.61	
BL 1023	1.25	1.19	0.19	0.44	1.15	31680	7216	2.88	0.44	0.62	0.62	—	0.59	0.57	
BL 1034					1.54	50600	8228	4.00				0.20	0.39	0.96	
BL 1044					1.73	61600	8734	4.56				0.39	0.39	1.15	
BL 1046					2.11	63360	9570	5.68				0.39	0.59	1.53	
BL 1066					2.49	94600	10054	6.80				0.39	0.39	1.91	
BL 1223	1.50	1.43	0.22	0.50	1.32	44000	11132	3.71	0.50	0.75	0.75	—	0.69	0.67	
BL 1234					1.78	70400	12694	5.16				0.23	0.46	1.13	
BL 1246					2.45	88000	14740	7.33				0.46	0.69	1.80	
BL 1423					1.52	52800	14652	5.47				—	0.79	0.76	
BL 1434	2.05	86900	16698	7.60	0.26	0.52	1.30								
BL 1446	2.80	105600	19404	10.79	0.52	0.79	2.04								
BL 1623	2.00	1.90	0.28	0.69	1.75	80300	17336	7.05	0.69	1.00	1.00	—	0.89	0.86	
BL 1634					2.34	156200	20922	9.80				0.30	0.60	1.45	
BL 1646					3.23	160600	24244	13.92				0.60	0.89	2.34	

Please contact us for these

Selection of leaf chain

Please consider BL type for new applications. AL type was removed from ANSI B29.8 Leaf chain standard in 1977.

The chain size is selected according to the following formula:
Acting tension x Service factor < Maximum allowable load

- Notes: 1. Acting tension includes the dead weight of the chain, the weight of the attachment and inertia.
2. If the chain speed exceeds 90ft/min, use a DID roller chain.

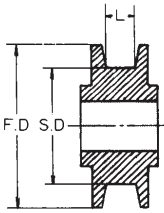



Minimum sheave diameter: $S.D = \text{Chain pitch} \times 5$
Minimum width between flanges: $L = \text{Overall length of pin} \times 1.05$

- If connecting pins are provided: $L1 \times 1.05$
- $L1$ is the value stated in the table of dimensions.
- $F.D = S.D + \text{Maximum link plate height (H)}$

Note: If dimension H exceeds 1.00, $F.D = S.D + 1.00$ can be adopted as the minimum flange outer diameter.



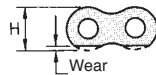

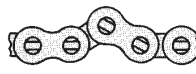
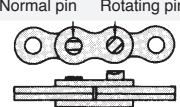
Periodical inspection and replacement for leaf chain

Be sure to provide periodical inspection and lubrication to maintain the safety and prolong chain life. Non-conforming conditions, and possible causes and solutions for such conditions for leaf chain are summarized in the following table.

Non-conforming condition	Possible Cause	Repair
Circumferential wear of plate 	Wear	Replace the chain if wear loss reaches 5 percent of H.
Oblique wear of plate and pin head 	Misalignment of guide or pulleys	Correct alignment.
Stiff link 	<ul style="list-style-type: none"> Dust or foreign materials in articulation Corrosion and rust Bent pin (Plastic deformation) 	<ul style="list-style-type: none"> Wash and re-lubricate Replace the chain. Replace the chain.
Abnormal protrusion or rotation of pin head 	Excessive tension or insufficient lubrication for the load	Replace the chain, improve lubrication and eliminate overload.

Service factor

Nature of load		Service factor	Examples of applications	Recommendation
Smooth transmission	When start and stop are smooth with small load varies.	1.0	For lifting a balance weight	AL type
With some light to medium shock	When start, stop, load variation or reversing occurs often.	1.2	Forklift, etc.	AL type and BL type
With large shock	When sudden start, stop or reversing occurs and when the load varies greatly.	1.4	Mining, construction machine, etc.	BL type and DID roller chains

Non-conforming condition	Possible Cause	Repair
Wear elongation 	Wear Plastic deformation (elongation) due to overload	Replace the chain at 1.03L. Note: Wear elongation of a chain reduces its tensile strength. Wear elongated of 3% reduces the tensile strength by 18 percent. The wear life of chain can be improved by lubrication. Replace the chain.
Cracked plate (1)  <p>Crack: From the hole of a link plate toward the end of the link plate in the direction perpendicular to tension direction</p>	Overload conditions	Replace the chain with a chain larger in maximum allowable load, or eliminate the overload condition or dynamic (shock) overload.
Cracked plate (2)  <p>Crack: In an oblique direction against tension direction</p>	Heavy rust or exposure to an acidic or corrosive environment	Replace the chain and protect from corrosive environment.
Broken plate (Tension direction) 	High level of overload	Replace the chain and eliminate the cause of overload.
Extended plate hole 	High level of overload	Replace the chain and eliminate the cause of overload.
Pitting Corrosion	Corrosive environment	Replace the chain and protect from corrosive environment.
Wear of connecting pin	Normal wear	Exchange the worn component.

British Standard Roller Chain

DID British Standard roller chain conform to the ISO "B series". The chain in conformity with the ISO-B standard is manufactured with the British Standard and German Standard.

For sprockets, use those in conformity with the British Standard.

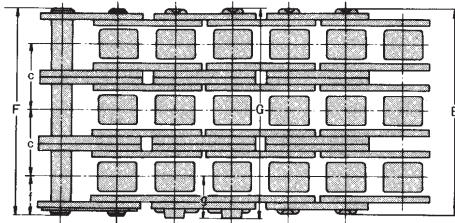
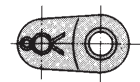
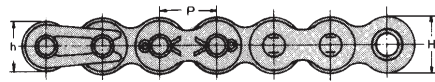
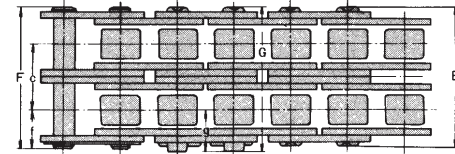
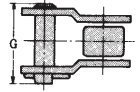
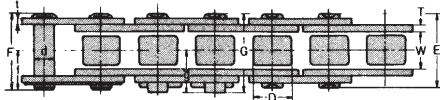

Clip Type
(12B & Smaller)

Cotter Type
(16B & Larger)

Offset Link

Dimensions

Unit (inch)

Chain No.		Pitch P	Roller Link Width W	Roller (Bush) Dia. D	Pin						Trans verse c	Plate				ISO "B" Min. Tensile Strength lbs	DID Avg. Tensile Strength lbs	Approx. Weight (lbs/FT)
DID	ISO "B"				d	E	F	G	f	g		T	t	H	h			
RC04B	04B	0.236	0.110	0.157	0.073	0.254	0.289		0.163			0.025	0.025	0.193	0.193	660	748	0.080
RC05B	05B	0.315	0.118	0.197	0.091	0.299	0.339		0.189		0.222	0.030	0.030	0.280	0.244	990	1276	0.121
RC05B-2	05B-2					0.522	0.561									1760	2068	0.228
RC06B	06B	0.375	0.225	0.250	0.129	0.518	0.535		0.291		0.403	0.051	0.039	0.323	0.323	2002	2354	0.262
RC06B-2	06B-2					0.896	0.941									3784	4356	0.496
RC06B-3	06B-3					1.299	1.350									5588	6160	0.738
RC08B	08B	0.500	0.305	0.335	0.175	0.657	0.713		0.390		0.548	0.059	0.059	0.469	0.409	4004	4400	0.449
RC08B-2	08B-2					1.209	1.260									6974	7700	0.872
RC08B-3	08B-3					1.756	1.811									9988	11000	1.287
RC10B	10B	0.625	0.380	0.400	0.200	0.744	0.803		0.429		0.653	0.059	0.059	0.579	0.512	4972	5720	0.577
RC10B-2	10B-2					1.398	1.457									9988	11440	1.127
RC10B-3	10B-3					2.055	2.114									14960	17160	1.703
RC12B	12B	0.750	0.460	0.475	0.225	0.874	0.929		0.500		0.766	0.071	0.071	0.634	0.575	6490	7040	0.764
RC12B-2	12B-2					1.642	1.697									12958	14080	1.529
RC12B-3	12B-3					2.413	2.469									19448	21120	2.320
RC16B	16B	1.000	0.670	0.625	0.326	1.378	0.000	1.500		0.811	1.255	0.157	0.126	0.819	0.819	13464	14300	1.717
RC16B-2	16B-2					2.638	0.000	2.756								23782	28600	3.433
RC16B-3	16B-3					3.898	0.000	4.012								35904	42900	5.090
RC20B	20B	1.250	0.770	0.750	0.401	1.614	0.000	1.732		0.925	1.435	0.177	0.138	1.024	1.024	21318	22000	2.555
RC20B-2	20B-2					3.047	0.000	3.169								38148	44000	5.076
RC20B-3	20B-3					4.488	0.000	4.606								56078	66000	7.577
RC24B	24B	1.500	1.000	1.000	0.576	2.102	0.000	2.311		1.260	1.904	0.236	0.197	1.224	1.224	35904	37400	4.748
RC24B-2	24B-2					4.008	0.000	4.217								62810	74800	9.321
RC24B-3	24B-3					5.913	0.000	6.122								95348	112200	13.881

Note: 1. The plate shape of 06B is straight edged.
2. The connecting link for 06B-12B is clip type and that for 16B-24B is cotter pin type.

4. Design of Roller Chain Transmission

- The description in this chapter can be applied when a chain is endlessly engaged for transmission with two sprockets parallel in their shafts and accurate in alignment as illustrated below.

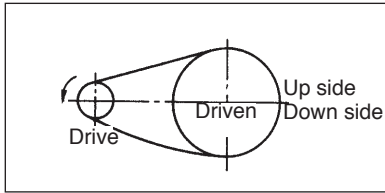

4-1 How to select the proper chain

The chain can be selected according to the following two methods:

- General selection
- Slow-speed selection

The general selection method (1) considers, not only chain tension but also the shock load on the bushing and rollers due to the engagement between the sprockets and the chain and the wear of pins, bushings and rollers.

The slow-speed method (2) is applied when the chain is operated at a speed of 164 ft/min or less. In general, the chain selected by this method is subject to conditions more severe than that selected according to method (1). Thus, careful assessment of conditions characterize this method.

4-1-1 General selection

First, the following information is required.

- Power to be transmitted (HP)
- Speeds of driving shaft and driven shaft (speed ratio) and shaft diameters
- Center distance between driving shaft and drive shaft

(a) Correction of power to be transmitted (HP)

Actual power to be transmitted is affected by the load and depends on the machine and power source used, to realize the expected service life (for example, 15,000 hours in the case of capacities shown in the table of maximum horsepower ratings). Correction must be made. An indicator of the degree of loading is the factor shown in Table 1. The power to be transmitted (HP) is multiplied by the corresponding service factor to obtain a corrected power.

$$\text{Corrected power (HP)} = \text{Power to be transmitted (HP)} \times \text{Service factor}$$

Table 1. Service Factor

Type of Drive Load	Type of Input Power		
	Electric Motor or Turbine	Inner Combustion Engine	
		with Multiple Cylinder or Hydraulic Drive	without Multiple Cylinder nor Hydraulic Drive
Smooth (ex. Agitator, Centrifugal Blower, Feeder,	1.0	1.0	1.2
Moderate Shock (ex. General work machines, Compressors, dryers)	1.3	1.2	1.4
Large Impact (Presses, Construction or mining machines, Vibration machines, General machine with reverse or Impact load)	1.5	1.4	1.7

- When a chain is to be used for lifting, pulling dollies or being engaged with a pin gear, etc., please consult us.
- To ensure that a selection has a sufficiently large allowance, select a chain in conformity with regulation guides, if any, and with reference to the maximum horsepower rating described below.

(b) Determination of number of teeth of chain and smaller sprocket

Use of simple selection chart

The number of teeth of the smaller sprocket and the chain to be used are tentatively decided with reference to the simple selection chart (P.66-P.67) and the corrected power (P.64-P.65).

Using the table of maximum horsepower ratings

If the results tentatively decided as described above are close to the design values, the number of teeth of the smaller sprocket can be determined with reference to the table of maximum horsepower ratings. The maximum horsepower ratings are established anticipating that an endless chain with 100 links has a life of 15,000 hours under the following conditions. (That is, the breaking of the chain and the coming-off of bushings and rollers do not occur at a wear elongation of 2 percent or less.)

- Operation is carried out in room temperature (14°F ~140°F) free from dust and dust-containing liquid.
- There is no corrosive gas, or humidity, etc. to adversely affect the chain.
- Proper lubrication is maintained.
- The chain is used under conditions of a low start-stop frequency and a fairly stable load.

For multiplex chain

Select a multiplex chain, when the capacity of a simplex chain is insufficient. The maximum horsepower rating of a multiplex chain cannot be obtained by multiplying the maximum horsepower rating of a simplex chain by the number of strands, since the load acting on the respective stands of the multiplex chain cannot be accurately divided. For the correction factor in this case, see the following table of multi-strand factors. Our K, KS Type Roller Chain and HKS Type Roller Chain are available up to triplex.

Table 2. Multi-Strand Factor

Number of Roller Chain Strand	Multi-Strand Factor
2	1.7
3	2.5
4	3.3
5	3.9

$$\text{Horsepower Rating of Multi-Strand Chain} = \text{Horsepower Rating of Simplex Chain} \times \text{Multi-Strand Factor}$$

Cautions for determining the number of teeth of smaller sprocket

When a chain of the minimum chain pitch required maximum horsepower rating is selected, relatively silent and smooth transmission can be achieved, and the equipment can be compact.

However, considering smooth chain transmission, the wear of the chain and sprockets, etc., it is desirable that the sprocket have 15 or more teeth, and preferably an odd number. Avoid 12 teeth, 14 teeth, 16 teeth, etc. as much as possible. If the sprocket has 12 or fewer teeth, the chain and sprocket will be heavily worn and vibrate, and transmission will not be smooth. Likewise, avoid a small number of teeth as much as possible except in the case of low speed without shock.

Examination of shaft diameter

When the number of teeth of the smaller sprocket is determined, multiply it by the speed ratio, and confirm whether the required shaft hole diameter can be secured in reference to the maximum shaft hole diameter in the table of sprocket dimensions. If the required shaft hole diameter is larger than the maximum shaft hole diameter, increase the number of teeth further or choose the next higher chain size and re-examine.

(c) Determine of the number of teeth of larger sprocket

When the number of teeth of the smaller sprocket is decided, multiply it by the speed ratio to determine the number of teeth of the larger sprocket.

In general, if the number of teeth of the sprocket is larger, the bending angle of the chain is smaller to increase durability and enhance transmission efficiency. However, if the number of teeth is too large, slight elongation tends to cause the chain to ride over the sprocket. So, keep the maximum number of teeth at 114 or less.

Speed ratio

A speed ratio refers to the ratio of the speed of the driving shaft to the speed of the driven shaft, and usually a speed ratio of 7 : 1 or less is safe. If the speed ratio is larger, the take-up angle of the chain on the smaller sprocket decreases, and the jumping of chain and abnormal sprocket wear are likely to occur. If a large speed ratio is necessary, selection of two-step speed change may be necessary.

4-1-2 Slow-speed selection

The slow-speed selection method is used when the chain operation speed is 164 ft/min or less and there is no worry of wear elongation and shock fracture of rollers and bushing.

In slow-speed selection, the chain is selected in reference to the tensile fatigue strength of the chain. Therefore, a chain selected according to this method will be subject to more severe conditions than one selected according to the general selection method. When the slow-speed selection method is used, special care must be exercised. For the connecting links and offset links, the slow-speed selection method cannot be used.

(a) How to obtain corrected chain tension

Corrected chain tension =
(Maximum tension acting on chain lbs x (Service factor))
See Table 1 on the previous page.

To calculate the corrected chain tension, correctly identify the maximum tension acting on the chain. The shock is considered to some extent in the service factor, but it is not absolute. Also consider the increase of tension by the inertia of equipment caused by starting and stopping.

(b) Comparison with the maximum allowable

Using the maximum allowable load stated in the table of dimensions of respective chain, the sprocket tooth factor, and speed factor of the smaller sprocket listed below, obtain the corrected maximum allowable load from the following formula:

Corrected maximum allowable load =
(Maximum allowable load)x(Sprocket tooth factor) x (Speed factor)
See the table of chain dimensions See the following Table 1. See the following Table 2.

If the corrected maximum allowable load is larger than the corrected chain tension, you can select the chain. For the number of teeth and speed of smaller sprocket not stated in Table 1 or 2, obtain the sprocket tooth factor and speed factor by linear interpolation.

Table 1. Sprocket Tooth Factor

Number of Tooth on Small Sprocket	Sprocket Tooth Factor CNT
9 T	0.903
11T	0.923
13T	0.939
15T	0.952
20T	0.978
23T	0.990
26T & over	1.00

Table 2. Rotating Factor

rpm on Small Sprocket	Rotating Factor CV
10 rpm & under	1.00
20 rpm	0.933
30 rpm	0.896
40 rpm	0.871
50 rpm	0.851
100 rpm	0.794
200 rpm	0.741

4-1-3 DID Standard Roller Chain Selection Chart

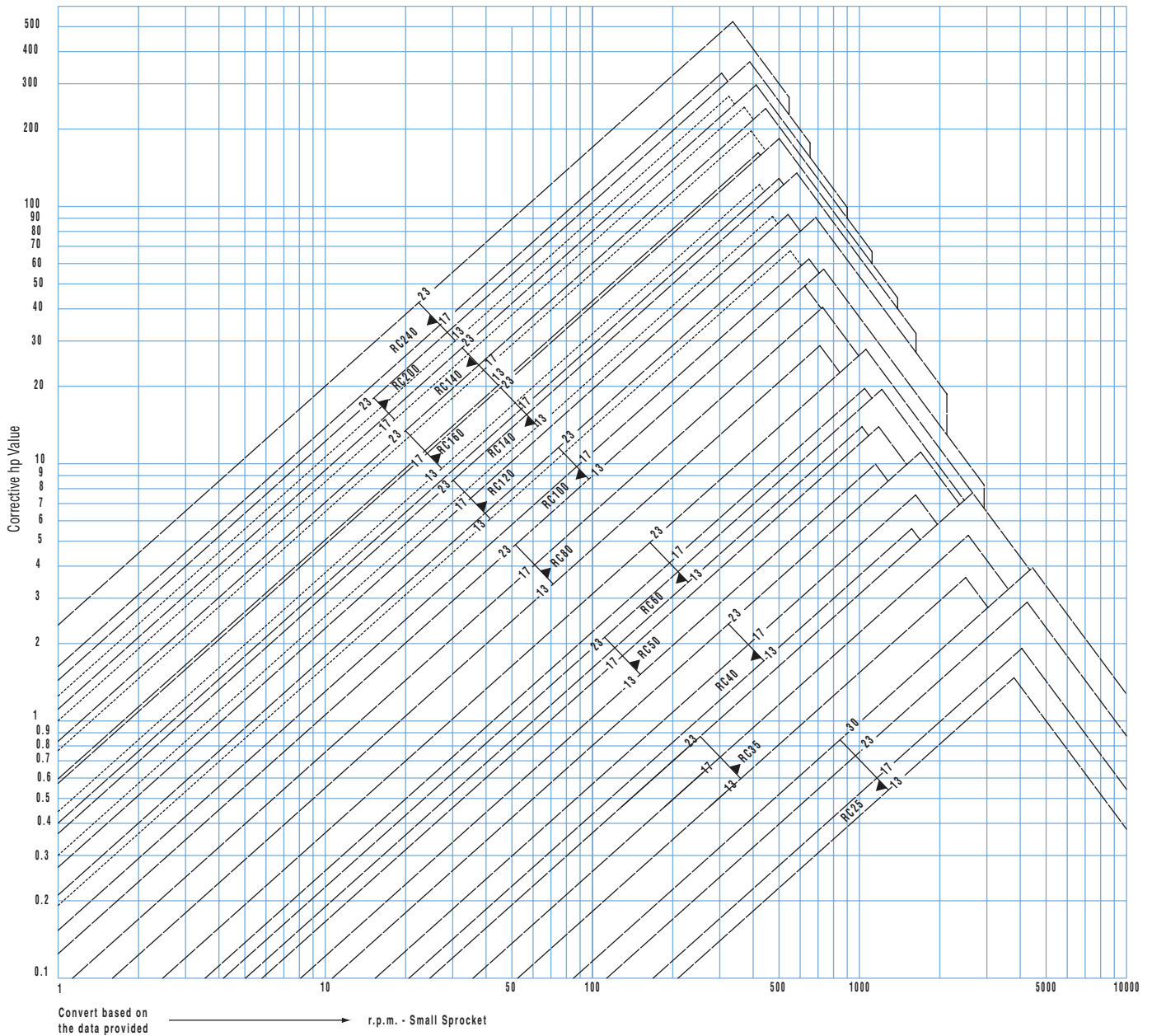

(How It Works)

Assuming that the corrected hp value and r.p.m. of small sprocket are 13hp and 100rpm respectively, the suggested roller chain size is read as "RC100" and the number of teeth on the small sprocket is read as "17". This is in reference to the intersection of the corrected horsepower value 13hp (vertical axis) and the number of small sprocket tooth (horizontal axis).

DID KS Type Roller Chain Selection Chart

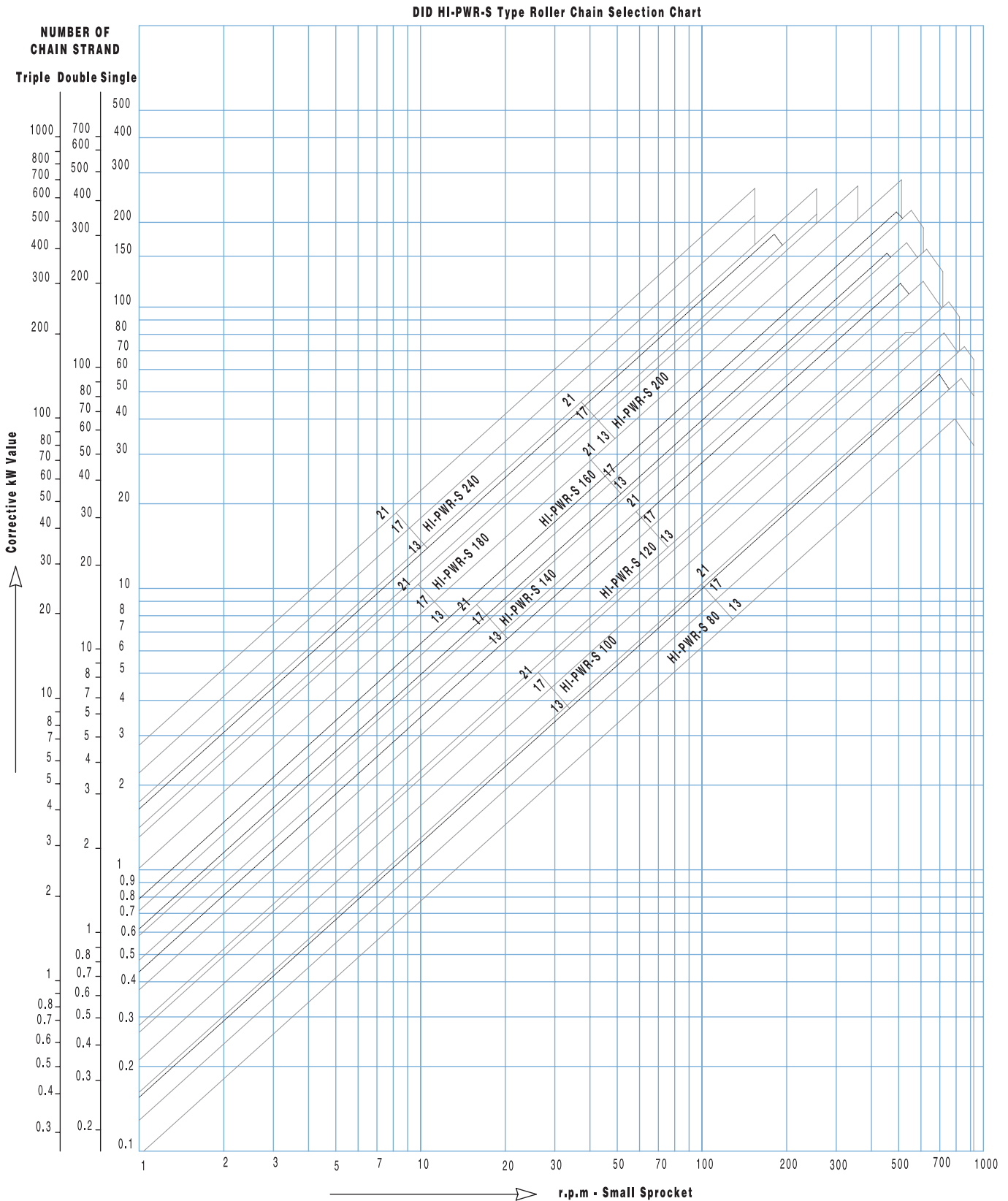

Convert based on the data provided

Please refer to P. 64 for how to use this chart.

KEY:

HI-PWR-S 240 = RC240 KSR	HI-PWR-S 140 = RC140 KSR
HI-PWR-S 180 = RC180 KSR	HI-PWR-S 120 = RC120 KSR
HI-PWR-S 200 = RC200 KSR	HI-PWR-S 100 = RC100 KSR
HI-PWR-S 160 = RC160 KSR	HI-PWR-S 80 = RC80 KSR

4-2 Chain Length and Sprocket Center Distance

Required length of roller chain

Using the center distance between the sprocket shafts and the number of teeth of both sprockets, the chain length (pitch number) can be obtained from the following formula:

$$L_p = \frac{N_1 + N_2}{2} + 2 C_p + \frac{\{N_2 - N_1 / 2 \pi\}^2}{C_p}$$

- Lp: Total length of chain (pitch number)
- N1: Number of teeth of smaller sprocket
- N2: Number of teeth of larger sprocket
- Cp: Center distance between two sprockets/Chain pitch

{(N2 - N1)/2π}² can be obtained from the following table.

The Lp (pitch number) obtained from the above formula can seldom be an integer, and usually includes a decimal fraction. Raise it to a unit to make it an integer.

If the number is odd, use a offset link. Select an even number as much as possible.

When Lp is determined, re-calculate the center distance between the driving shaft and driven shaft as described in the paragraph below. If the sprocket center distance cannot be altered, eliminate the chain sag using an idler or chain tightener shown on P.69.

Center distance between driving and driven shafts

The center distance between the driving and driven shafts must be, of course, more than the sum of the radius of both sprockets. In general, it is said that a proper sprocket center distance is 30 to 50 times the chain pitch.

However, if the load is pulsating, 20 times or less is proper.

The take-up angle between the smaller sprocket and the chain must be 120

or more. If the roller chain

length Lp is given, the center distance between the sprockets can be obtained from the following formula:

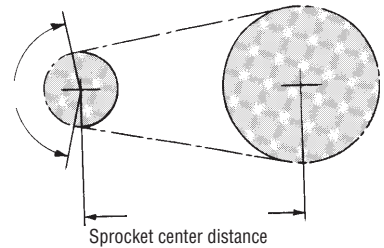

$$C_p = \frac{1}{4} \left\{ L_p - \frac{N_2 - N_1}{2} + \sqrt{\left(L_p - \frac{N_2 - N_1}{2} \right)^2 - \frac{2}{\pi^2} (N_2 - N_1)^2} \right\}$$

Cp: Sprocket center distance (pitch number)

Lp: Total length of chain (pitch number)

N1: Number of teeth of smaller sprocket

N2: Number of teeth of larger sprocket

N ₂ -N ₁	{(N ₂ -N ₁)/2π}²	N ₂ -N ₁	{(N ₂ -N ₁)/2π}²	N ₂ -N ₁	{(N ₂ -N ₁)/2π}²
1	0.03	35	31.03	69	120.60
2	0.10	36	32.83	70	124.12
3	0.23	37	34.68	71	127.69
4	0.41	38	36.58	72	131.31
5	0.63	39	38.53	73	134.99
6	0.91	40	40.53	74	138.71
7	1.24	41	42.58	75	142.48
8	1.62	42	44.68	76	146.31
9	2.05	43	46.84	77	150.18
10	2.53	44	49.04	78	154.11
11	3.07	45	51.29	79	158.09
12	3.65	46	53.60	80	162.12
13	4.28	47	55.96	81	166.19
14	4.97	48	58.36	82	170.32
15	5.70	49	60.82	83	174.50
16	6.49	50	63.33	84	178.73
17	7.32	51	65.88	85	183.01
18	8.21	52	68.49	86	187.34
19	9.14	53	71.15	87	191.72
20	10.13	54	73.86	88	196.16
21	11.17	55	76.62	89	200.64
22	12.26	56	79.44	90	205.17
23	13.40	57	82.30	91	209.76
24	14.59	58	85.21	92	214.40
25	15.83	59	88.18	93	219.08
26	17.12	60	91.19	94	223.82
27	18.47	61	94.25	95	228.61
28	19.86	62	97.37	96	233.44
29	21.30	63	100.54	97	238.33
30	22.80	64	103.75	98	243.27
31	24.34	65	107.02	99	248.26
32	25.94	66	110.34	100	253.30
33	27.59	67	113.71		
34	29.28	68	117.13		

N ₂ -N ₁	{(N ₂ -N ₁)/2π}²	N ₂ -N ₁	{(N ₂ -N ₁)/2π}²	N ₂ -N ₁	{(N ₂ -N ₁)/2π}²
1	0.20	35	248.24	69	964.78
2	0.81	36	262.63	70	992.95
3	1.82	37	277.42	71	1021.52
4	3.24	38	292.62	72	1050.50
5	5.07	39	308.22	73	1079.88
6	7.30	40	324.23	74	1109.67
7	9.93	41	340.64	75	1139.87
8	12.97	42	357.46	76	1170.46
9	16.41	43	374.69	77	1201.47
10	20.26	44	392.32	78	1232.88
11	24.52	45	410.35	79	1264.69
12	29.18	46	428.79	80	1296.91
13	34.25	47	447.64	81	1329.54
14	39.72	48	466.89	82	1362.57
15	45.59	49	486.55	83	1396.01
16	51.88	50	506.61	84	1429.85
17	58.56	51	527.07	85	1464.09
18	65.66	52	547.95	86	1498.74
19	73.15	53	569.22	87	1533.80
20	81.06	54	590.91	88	1569.27
21	89.37	55	612.99	89	1605.13
22	98.08	56	635.49	90	1641.41
23	107.20	57	658.39	91	1678.08
24	116.72	58	681.69	92	1715.17
25	126.65	59	705.40	93	1752.66
26	136.99	60	729.51	94	1790.55
27	147.73	61	754.03	95	1828.85
28	158.87	62	778.96	96	1867.55
29	170.42	63	804.29	97	1906.66
30	182.38	64	830.02	98	1946.18
31	194.74	65	856.17	99	1986.10
32	207.51	66	882.71	100	2026.43
33	220.68	67	909.66		
34	234.26	68	937.02		

TRANSMISSION ROLLER CHAIN
ENGINEERING INFORMATION

4-3 Layout

When a roller chain is used, shaft positions can be optionally determined. However, in principle, decide as illustrated below. That is, if the chain is tensioned horizontally, keep the top tensioned. Avoid vertical transmission whenever

possible. In an inevitable case, place the larger sprocket below regardless of the direction of rotation.

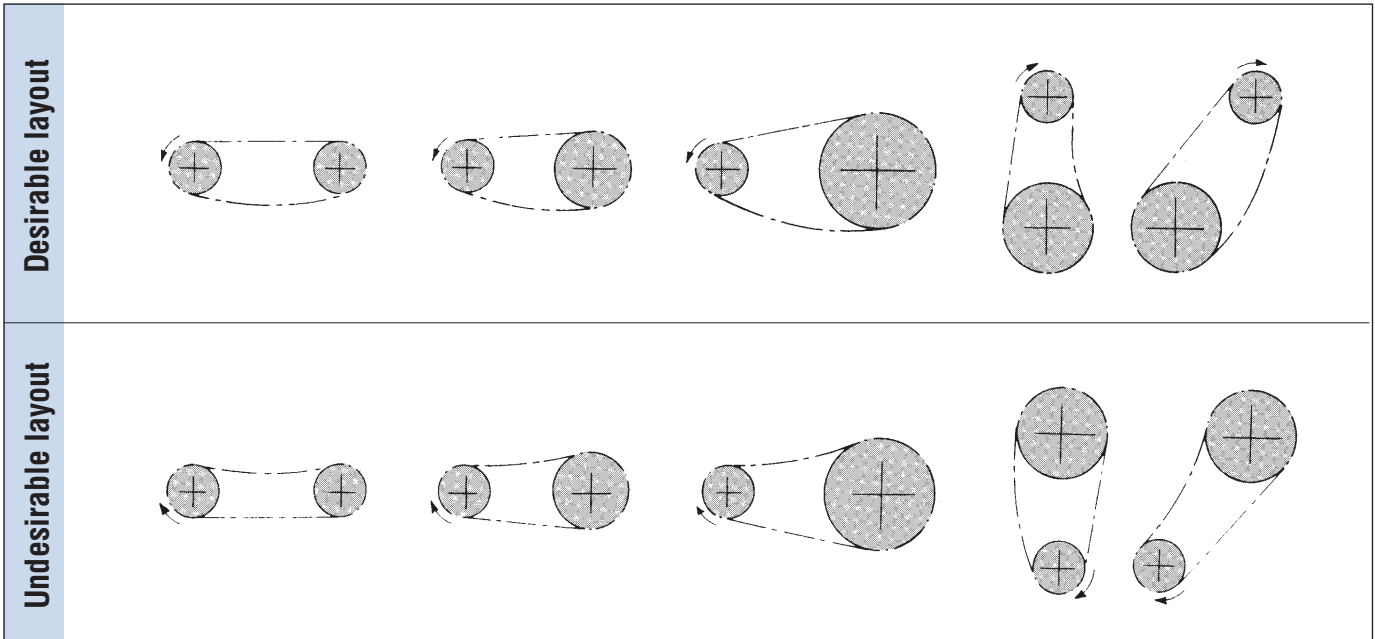

*Each shaft with an arrow is a driven shaft.

When the chain layout is undesirable:

- When the top is sag and the sprocket center distance short: As illustrated below, adjust the sprocket center distance shaft to eliminate the sag.

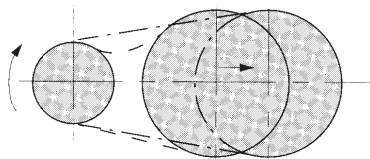

- When the top is sag and the sprocket center distance long: As illustrated below, install an idler from inside to eliminate the sag.

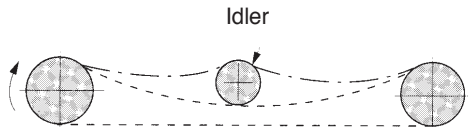

- When the chain is vertical or inclined: As illustrated below, eliminate the extra sag by a tensioner. In this case, a tensioner that eliminates sag automatically gives better results.

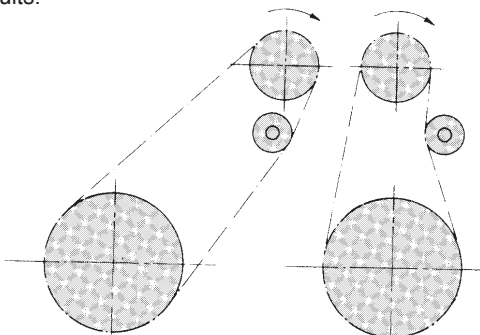

When a pulsating load acts in high speed operation:

The natural frequency of the chain and load shock cycle or chordal action can be synchronized to vibrate the chain. Vibration adversely affects the chain. Prevent it by any of the following methods:

- Change the chain speed.
- Increase chain tension. However, note that over-tensioning can shorten the life of the chain.
- Use an idler or tensioner to divide the span.

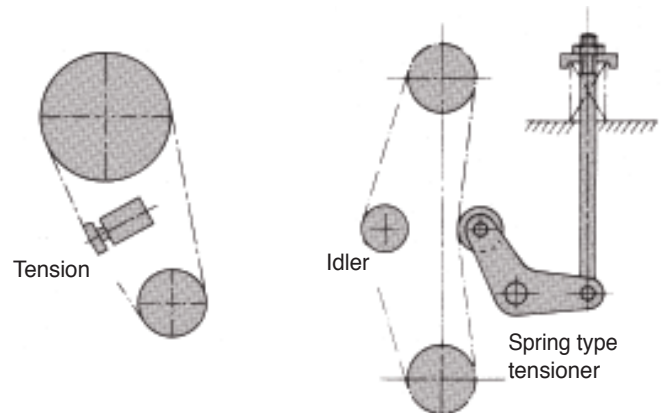

- Install a guide stopper to prevent vibration.

Note: Chordal action refers to the vertical motion of chain caused when it is engaged with sprockets.

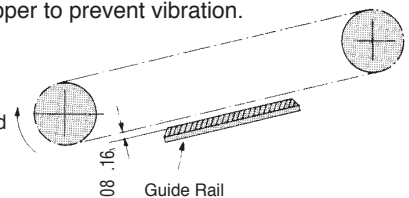

5. Installation, Adjustment and Maintenance

5-1 Installation

5-1-1 Installation of sprockets

For smooth transmission and extended life of the roller chain, it is important to correctly install proper sprockets. Use the following installation procedure.

1. Correctly install a sprocket on a shaft, and fix it by a key, etc. to the shaft to prevent play between the sprocket and shaft during operation.

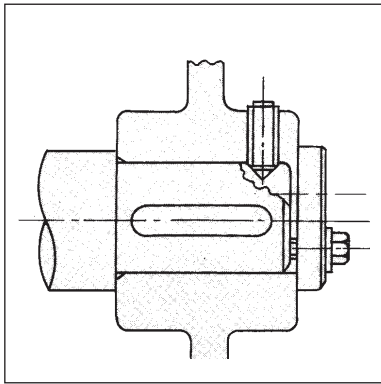

2. Adjust the axial measurement using a level, to within $\pm 1/300$.

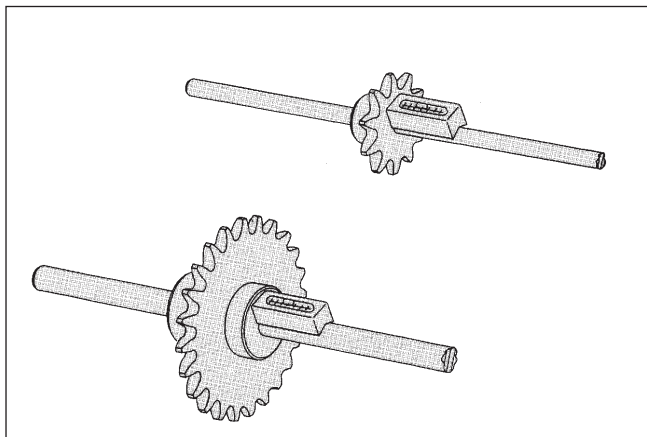

3. Adjust the parallel measurement ($\frac{A-B}{L}$) to it within $\pm 1/300$.

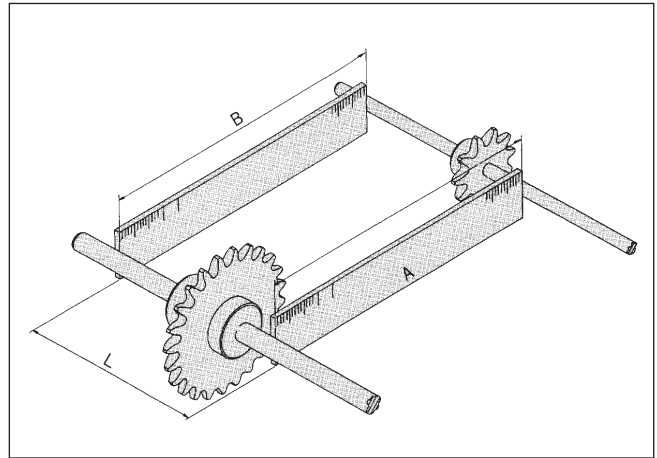

4. Adjust the driving and driven sprockets using a straight edge so they are on the same plane. (Also adjust the idler and the sprockets, or the tensioner and the sprockets similarly.)

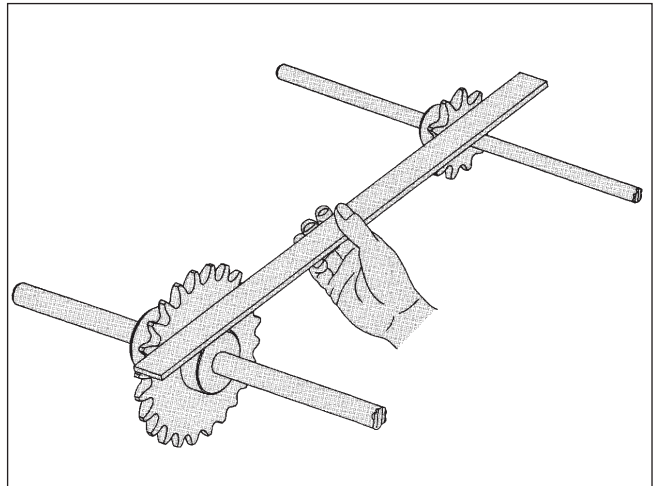

Keep the allowance σ within the following value.

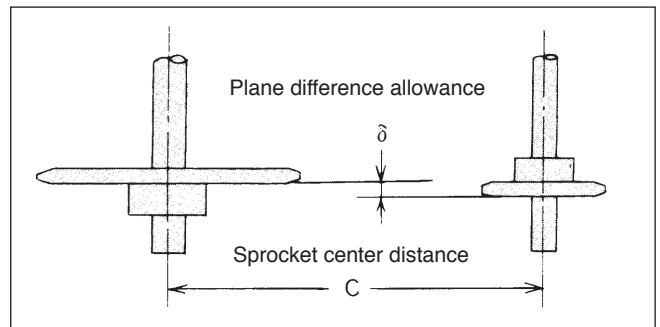

Sprocket center distance C	Allowance δ (in)
up to 3.3 Ft	± 0.04
3.3 ~ 33 Ft	$\pm C$ (in) /1000
over 33 Ft	± 0.4

5-1-2 Installation of roller chain

When connecting a chain after engaging it with the sprockets, observe the following procedure.

When using the sprocket teeth

1. Engage the chain with the sprockets that both ends of the chain are on either of the sprockets, as shown in the following photo.
2. Insert connecting link pins in the ends of chain.
3. Install a connecting link plate, and fasten with a spring clip or cotter pins.



In installation take extra care to avoid damaging sprocket teeth.

Cautions

1. When connecting plate is fastened with a spring clip, apply the spring clip to the grooves on the connecting pins as illustrated below, and lock it using pliers, etc. As for the direction of spring clip insertion, keep the opening to opposite direction of chain rotation, as illustrated below.

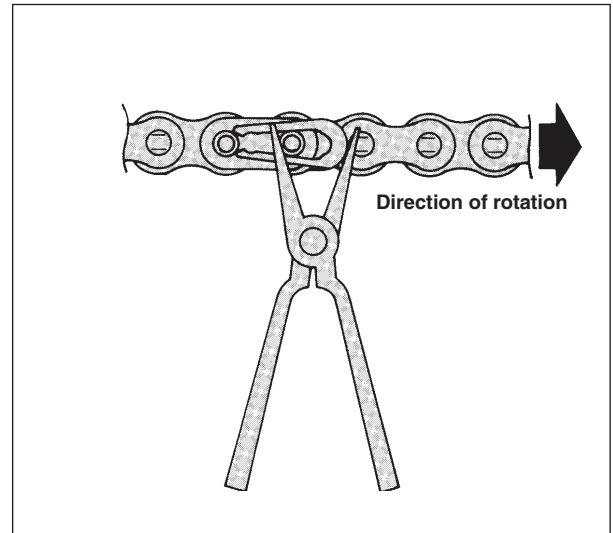

2. In a place where the sprocket center distance can be adjusted minimally, an odd number of links may be used. However, add one link, to use an even number of links, and eliminate the sag by shifting a sprocket or installing an idler.
3. When a semi press fit connecting link is used, pins must be driven into the connecting plate because of interference. In this case, ensure that the pair of pins are kept parallel to each other when inserted into the connecting plate. Never make the holes of the connecting plate larger or make the pins thinner for easier connection work. This applies also when a cotter type outer link (CP) is used instead of a connecting link.

Connection of O-ring chain for general application

When an O-ring chain for general application is connected, the following should be kept in mind:

1. A connecting link of an O-ring chain for general application is pre-coated with grease on the pins. Before connection, make sure the grease is on the surfaces of pins, and if the amount of grease is insufficient, apply grease manually. (If a glove is used, the grease may be absorbed by the glove.) Example: When the connecting link (I) of a O-ring chain for general application is shipped, O-ring are fitted at the roots of the pins. If the O-ring comes loose due to vibration during transport,

refit the O-ring in to the roots of the pins. In this case, be sure to return the grease collected at the roots of the pins to the central surfaces of the pins, more at portions A than at portions B in the above illustration. (Portions A are worn because of sliding with the bushings.)

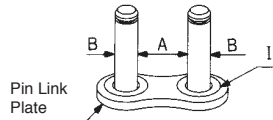

2. The chain can be easily connected if worked on the teeth of a sprocket. Engage the links at both the ends of the chain with the sprocket teeth and fit connecting pins. If the sprocket can be moved, the chain can also be connected on the sag side.

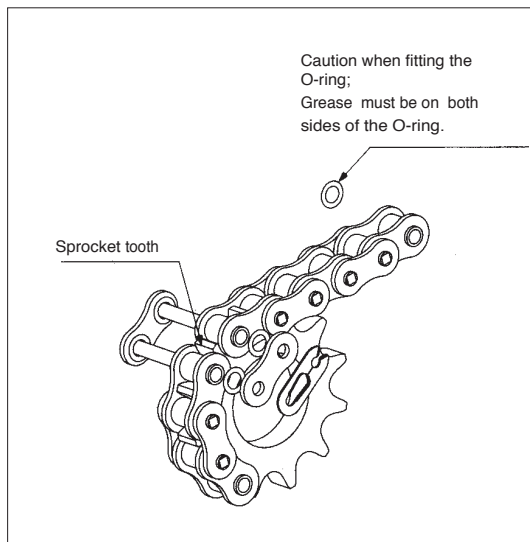

3. Connecting procedure

1. Confirm whether O-ring are installed at the roots of the pins.
2. If the amount of grease applied on the connecting pins is small, coat the pins with grease at the central portions.
3. Insert the connecting pins into the bushings of the inner links at both ends.
4. Confirm that the grease is applied to the entire face of the O-ring, and fit the O-ring onto the connecting pins.
5. Insert the connecting pins into the connecting plate and while pressing the connecting plate, install the spring clip. Confirm whether the head (the end without a split) of the spring clip is turned in the progression direction of the chain. (See the following illustration.)
6. Be sure to confirm that the spring clip is securely fitted in the clip grooves of the connecting pins.

This completes installation of the connecting link. Note that grease on the surfaces of connecting pins and O-ring can be removed during installation work. In this case, re-grease using the grease on the surface of the base chain or the grease in the polyethylene bag in which the connecting link was contained.

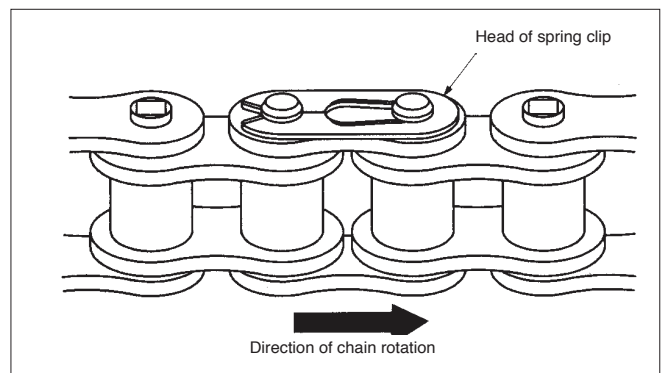

5-2 Maintenance

5-2-1 Check

A. Confirm the following before operation

Connected joint	<ul style="list-style-type: none"> Confirm whether the connection is sufficient and whether components are normal. Confirm whether bending is smooth. (in the case of O-ring chain, bending is slightly stiff).
Chain sprocket attachment	<ul style="list-style-type: none"> Confirm whether there is any serious flaw, rust or wear. Confirm whether sag is proper. Confirm whether any pin rotates. Confirm whether rollers rotate smoothly. Confirm whether the chain engages the teeth of sprockets.
Interference	<ul style="list-style-type: none"> Confirm whether there is anything interfering with the chain, or whether anything is likely to interfere with the chain or safety cover.
Lubrication	<ul style="list-style-type: none"> Confirm whether the amount of lubrication is appropriate. (For the amount of lubrication, see the table of lubrication types.)
Driving and driven shafts	<ul style="list-style-type: none"> Confirm whether the axial measurement and parallel measurement are proper. Confirm whether the difference of sprocket planes is within the allowance.
Peripheral equipment	<ul style="list-style-type: none"> Confirm whether peripheral equipment is installed correctly.

- B. After confirmation and adjustment of the above A, install the safety cover, and switch on the power to start operation.
- It is possible for the chain to be thrown should it break. Do not stay in the direction of rotation during operation.



Caution

- Obstacles** • Obstacles may cause breaking or fracturing which can scatter pieces and injure persons nearby. Be sure to remove all obstacles.
- Abnormal noise** • Abnormal noise during operation is a sign of trouble. Immediately switch off the power, and determine the cause.
- Flaws and rust** • If any serious flaw or rust is visible, it may cause the chain to break and fracture and possibly injure a person nearby. Confirm whether the chain has any potentially harmful flaw or rust.
- Sprocket** • If a sprocket is worn, the sprocket may break, or the chain may ride over the sprocket, breaking it and possibly resulting in injury to a person nearby. Confirm whether or not the sprockets are worn.
- Devices that prevent accidents** • Install accident prevention devices. To avoid injury caused by scattered pieces, install accident prevention devices (safety cover, drop net, etc.).
• Install an emergency shutdown device. To avoid injury due to unexpected overload, install an emergency shutdown device such as a load controller or brake.

Before trial operation

Confirm the status of chain installation before starting operation.

- Whether the chain correctly engages the sprockets.
- Whether the joint is normal. (Whether the spring clip is incorrectly installed or whether cotters are bent.)
- Whether chain sag is proper.
- Whether the chain contacts the chain case.
- Whether lubrication is proper.

Checks during trial operation

If the chain can be manually rotated, rotate it to confirm no abnormality before starting trial operation.

Be alert to the following during trial operation.

- Whether there is abnormal noise
If the chain contacts the chain case or if the chain heavily vibrates, abnormal noise occurs. Check the installation of chain case chain sag.
- Whether lubrication is normal during operation
Re-check the condition of lubrication.

5-2-2 Elongation limit of chain Sag and elongation of chain

- Events caused by sag failure

Even if the sag of the chain is normal before start of operation, it can increase if the chain is elongated by worn pins, bushings, etc. If the sag is excessive, the following will occur.

- Abnormal vibration
- Chain rollers ride over the heads of sprocket teeth
- The chain is seized by a sprocket
- The chain contacts the chain case

These conditions can often cause abnormal noise. Should any abnormal noise occur, immediately stop operation, and check carefully to determine the cause. Such conditions occur not only when the chain is broken, but also when there is an equipment problem. A preliminary check is necessary.

• Elongation limit of chain

Even if sag adjustment is normal, excessive elongation of the chain can cause similar abnormality, inhibiting smooth transmission. In such a case, replace the chain. The elongation of chains to the extent that replacement is recommended is listed below. Even if only one link reaches the elongation limit, replace the entire chain with a new one. Unless lubrication is normal, the chain will elongate quickly, causing the aforementioned troubles. Adequately understand the contents of "Lubrication" in the next section, for performance of maintenance.

Elongation limits of chain

Number of teeth of larger sprocket	Regular chain	Sealed chain and sintered bushing roller chain
40 or less	2.0%	1.0%
41 ~ 60	1.5	1.0
61 ~ 80	1.2	1.0
81 ~ 100	1.0	1.0
101 or more	0.8	0.8

* If elongation of a sealed chain or sintered bushing roller chain exceeds the value in the above table, the chain becomes equivalent to a standard chain, and is accelerated compared to the wearing rate until then.

* The above elongations are applicable when the chain can be taken up or when a sag adjusting device is installed. If the shafts are fixed without any sag adjusting device, the recommended elongation limit is 0.5 to 0.7%.

• Elongation measuring method

- To eliminate other than a slight amount of play in the chain as a whole, measure with the chain lightly tensioned.

Note: For the sake of accuracy, the chain is tensioned by a length measuring load specified by JIS/ANSI during measurement.

- As illustrated below, between the rollers for the number of links to be measured, the inner length (L1) and the outer length (L2) are measured to obtain the judgment length (L).

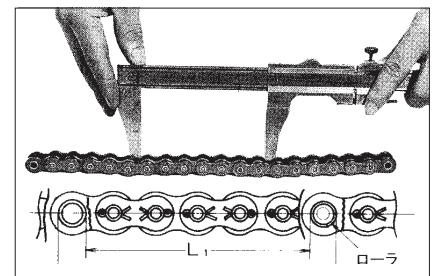

- Then, obtain chain elongation.

Chain elongation =

$$\frac{(\text{Judgment length} - \text{Reference length})}{\text{Reference length}} \times 100 (\%)$$

Reference length = Chain pitch x number of links

- For measurement, measure the length of about six to ten links to keep the measurement error as small as possible.

Chain wear-elongation check gage

We recommend and can supply a chain wear-elongation check gage (P.73) that facilitates finding the elongation limit.

5-2-3 Sag adjustment of roller chain

To use a roller chain for a longer period of time, proper sag is an important point to consider. If the roller chain is over-tensioned, the oil film between pins and bushings is lost, shortening chain life and damaging the bearings. If the chain is excessively sagged, the chain will vibrate or be seized by the sprocket. In about 50 hours (though depending on the service conditions) after starting the roller chain use, the chain will be elongated by about 0.1 percent of the entire length due to the conformability of respective contacts. So, adjust the sag at this time. Thereafter, if proper lubrication is maintained, the elongation will be negligible. Check and adjust the sag at the proper intervals.

Optimum sag

In general, sag S is about 2 percent of the span L , but in the cases described below, it is about 1 percent.

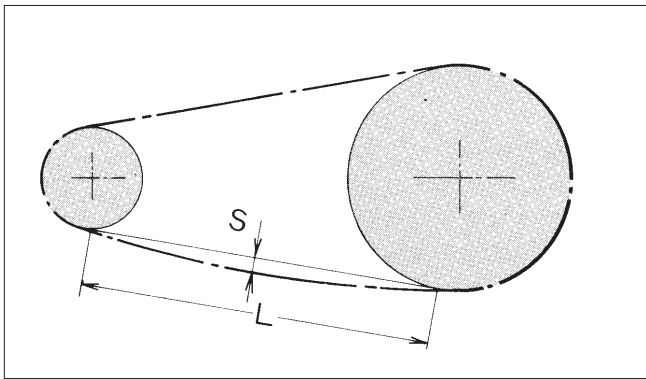

Keep sag at $0.01L$ or less in the following cases:

- o When the chain is installed vertically or almost vertically
- o When the chain is installed horizontally or almost horizontally with the top slackened
- o When the center distance between sprockets exceeds 50 times the chain pitch
- o When vibration or shock occurs
- o When the chain is frequently started and stopped
- o When the chain is suddenly reversed
- o When the speed ratio is 7 : 1 or more (keeping the speed ratio at 7 : 1 or less is safer and preferable)

Sag adjusting method

Sag can be adjusted by the following methods.

1. Adjustment of center distance between shafts

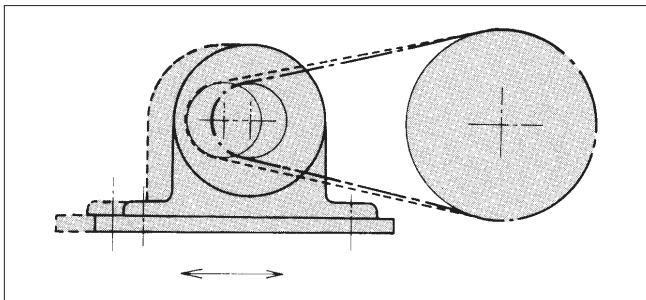

2. Adjustment using a tensioner or idler

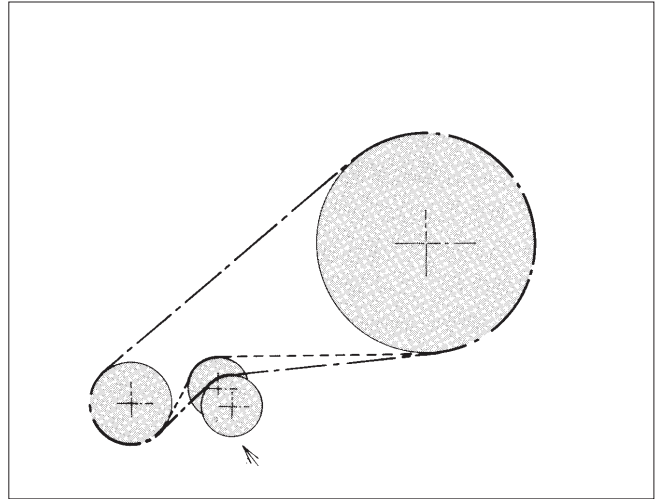

3. Increase or decrease of pitch number by offset link

By using a offset link, the total length of a chain can be increased or decreased by one pitch. However, since offset link performance is generally poor, an even number of links, if possible, is recommended.

5-2-4 Other checks

- Checking sprocket

If a sprocket is not installed at the correct position of the shaft or is not parallel to the shaft, the plates of the chain may be flawed, or the chain may be twisted. This can be judged by examining the contact faces of the sprocket teeth. In this illustration, a uniform contact as indicated by A is normal. If the contact is different on both sides as indicated by B, correction is necessary.

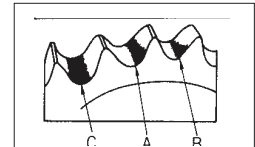

- Checking idler or tensioner

When sag is adjusted, check also whether the idler or tensioner itself is damaged. If the contact between an idler or tensioner and a chain is at the center of the tooth gap bottom as indicated by C, it is normal. If the contact is as indicated by A or B, the bearing of the idler or tensioner may be abnormal.

- Checking chain accessories

In the case of a chain with attachments, if a mounted part is loosely installed or comes off, an accident can result. Furthermore, if an installation hole is enlarged due to wear, the life of the chain may be shortened.

For problems during operation, see "Trouble Shooting".

5-3 Lubrication

5-3-1 Necessity of lubrication

In a roller chain transmission, even if the chain and sprockets are designed to suit the service conditions, poor lubrication inhibits maintaining performance and life to design specifications. In the case of a roller chain, the wear loss caused under proper lubrication is dramatically different from that caused without it. Troubles caused due to insufficient lubrication include the wear of pins and bushings, rough engagement with the sprockets, increased noise, and breakage as a result of prolonged undesirable conditions. Proper lubrication is very important. Locations and the effect of proper lubrication are listed below.

Proper lubrication locations	Effect of proper lubrication
<ul style="list-style-type: none"> • Selection of lubricating oil. See 5-3-2. • Lubricating points See 5-3-3. • Lubrication type (lubricating method, lubrication, intervals, amount of lubrication) See 5-3-4. 	<ul style="list-style-type: none"> • The wear of frictional portions is decreased. • Power loss is decreased. • Seizure is prevented. • Frictional heat is decreased. • Generated heat is eliminated. • Ensure smooth operation and extends machine life.

5-3-2 Selection of lubricating oil

Select the lubricating oil of a roller chain in reference to the lubrication type (P. 76), ambient temperature and chain No., according to the following table.

Lubricating oil should be a mineral oil of good quality. It is important that the lubricating oil contains no dust or foreign matter. Never use waste oil. If the ambient temperature is lower than 14° F or higher than 140° F, a special oil is necessary. In this case, please consult our engineering department.

Type of Lubrication Chain No.	A, B				C			
	-10°C ~0°C (14°F~32°F)	0°C ~40°C (32°F~104°F)	40°C ~50°C (104°F~122°F)	50°C ~60°C (122°F~140°F)	-10°C ~0°C (14°F~32°F)	0°C ~40°C (32°F~104°F)	40°C ~50°C (104°F~122°F)	50°C ~60°C (122°F~140°F)
RC25~RC50	SAE10W	SAE20	SAE30	SAE40	SAE10W	SAE20	SAE30	SAE40
RC60~RC80	SAE20	SAE30	SAE40	SAE50				
RC100					SAE50	SAE30	SAE40	SAE50
RC120~RC240	SAE30	SAE40	SAE50					

Specially designed lubricant must be applied when atmospheric temperature is under 14°F or over -140°F. Please consult with us for appropriate selection of lubricant.

5-3-3 Lubricating points

If the chain is immersed in an oil bath, oil will penetrate every part of the chain. In the case of manual lubrication, brush lubrication or drip lubrication, ensure that the oil sufficiently penetrates the portions of ① and ② in the following illustration.

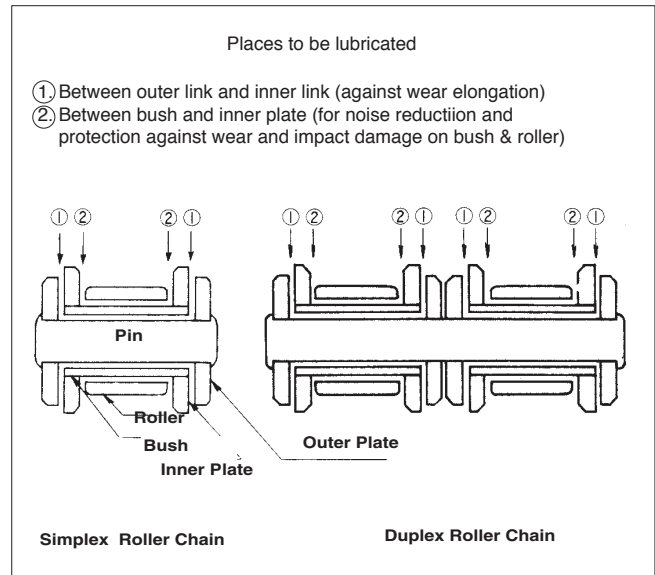

Lubricate on the sag side of the chain, i.e., at the position indicated in the following illustration. Since the lubricating oil is also useful for rust prevention, coating the entire surface of the chain with the oil is recommended.

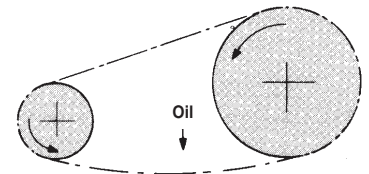

5-3-4 Lubrication Types (Explanation of A, B and C in the tables of maximum horsepower ratings)

The chain is selected with reference to the table of maximum horsepower ratings, and the allowable horsepower rating for a case where the chain size, number of sprocket teeth and speed are decided is based on the assumption that any of the following appropriate types of lubrication is adopted. If any

of the following lubrication types cannot be adopted or in an environment where earth, sand or dust exists, use the DID Ultimate Life Chain Series (see P. 43).

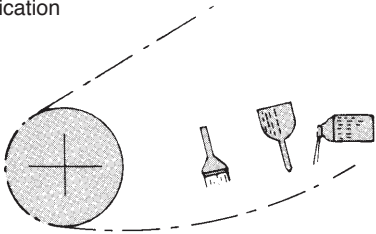
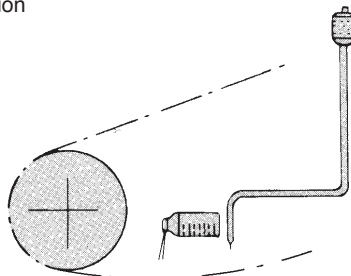
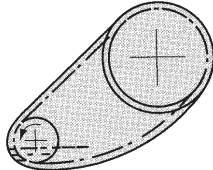
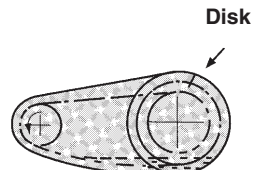
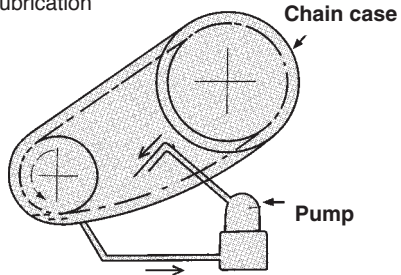
Lubrication type	Name and method	Lubrication intervals and amount	Caution
A Use DID Chain Lube (see P.75).	Manual lubrication Brush lubrication 	Carry out periodical manual or brush lubrication, at least once a day.	While rotating the chain slowly, lubricate the entire length uniformly three to four times. Take care not to allow your hand or clothes to be caught by the chain during lubrication. Note that extra oil will be scattered when the operation is started.
	Drip lubrication 	Supply about five to 20 drops of oil per one minute.	In this case, since extra oil is scattered, installing a simple casing is recommended.
B	Oil bath lubrication 	Keep the chain immersed in oil, about 10 mm below the oil surface. If immersion is too deep, the oil will become abnormally hot.	Oil bath should be leak proof. Before using the case for the first time, thoroughly wash the inside to remove dust and other foreign matter.
	Disc lubrication 	A disc is used to apply oil to the chain. Keep the disc immersed in oil, at a depth of about .787". Keep the peripheral speed higher than 656 ft/min.	
C	Forced fed lubrication 	The amount of lubrication must be set to avoid abnormal heating. In general, the amount should not allow the chain temperature to exceed 140°F.	The case leak proof. When using the case for the first time, thoroughly wash the inside to remove all dust and foreign matter.

5-3-5 General cautions for lubrication

Unless normal lubrication is carried out, chain fatigue will result, causing various problems. Careful inspection is necessary.

In the case of insufficient lubrication

If the lubricating oil is exhausted, red rust is generated between the inner and outer plates, causing sudden wear. Therefore, the lubricating oil must be applied before this happens. When a chain whose lubrications is exhausted is disassembled, red rust is visible on the surfaces of pins, and the surfaces are roughened, as shown in this photo. (Normally, pins have a mirror finish.)



Do not use grease for lubrication !!

Do not use grease to lubricate your chain, since it takes too long for grease to reach the clearances between pins and bushings at room temperature. Use the machine oil shown in the table on P. 75 or DID Chain Lube (a spray lubricant).

Before lubrication, remove foreign matter and dirt from the chain as thoroughly as possible. If water is used for washing the chain, quickly dry it, then lubricate to prevent corrosion.

In the case of drip lubrication, oil bath lubrication or forced feed lubrication

In this case, check to ensure that:

1. The lubricating oil is not dirty.
2. The amount of lubricating oil is correct.
3. Lubricating oil is uniformly applied to the chain.

Cautions

Dust contamination must be avoided to maintain wear resistance. If temperature rises abnormally or the chain squeakes, the oil may be exhausted. Verify by checking.

5-4 Troubleshooting Guide

Trouble	Possible cause	Correction
A pin, bushing or roller is fractured. Note: "Fracture patterns of respective components of chain" on P. 79.	High speed rotation exceeding the tolerance of chain and sprockets	Lower the speed, or select a chain with a smaller pitch. Otherwise, select a sprocket with a larger number of teeth. In this case, refer to general selection details (P.91).
	Sudden large shock load	Avoid shock load as much as possible. Install a damper, etc., to damp the shock load.
	Improper lubrication	Periodically supply the correct lubricating oil. Spray type chain oil "DID Chain Lube" is recommended.
	Corrosion of chain	Check the service environment and lubrication condition, and select a proper chain.
	Wear of sprocket	Replace it with a new one. Use a sprocket conforming to the correct standard dimensions.
	Check for foreign objects.	Immediately remove foreign matter; strictly control the service environment.
Abnormal noise	Chain is excessively tensioned or slackened.	Pay constant attention to the chain sag. Correct by adjusting it according to the procedure stated in "Sag adjustment of roller chain" (P. 74).
	Incorrect alignment of sprockets	Check the alignment between both the larger and smaller sprockets.
	Large wear elongation of chain or wear of sprocket	Replace a chain that is elongating beyond the tolerance and replace worn sprockets with new ones.
	Incorrect installation of chain case	If the chain contacts the chain case, immediately correct and adjust.
	Improper lubrication	Lubricate properly and periodically. (See "Lubrication types" (P. 76).
	Improper combination of chain and sprockets	When replacing the chain, use the correct chain size and sprocket sizes. Select a chain suitable for sprocket sizes, and sprockets suitable for the chain size. (Especially when an HK Type Series Multiplex Chain is replaced, sufficient care is necessary.)

Trouble	Possible cause	Correction
When the chain rides over a sprocket.	Excessive wear elongation of chain	Replace an excessively worn chain.
	Chain too slack	A chain with too much slack causes the chain to ride over a sprocket, and can damage the tooth heads of a sprocket. Correctly adjust it.
	Worn sprocket or deposit of foreign matter on tooth gap bottom	Replace a worn sprocket with a new one. If foreign matter is deposited on a tooth gap bottom, immediately remove it.
Wear of plates and sprockets on their lateral sides	Incorrect alignment of sprockets	Misalignment of drive and driven sprockets result in abnormal wear of sides of link plate, thereby shortening chain life. Apply a straight edge to the lateral sides of sprockets, to check alignment.
Vibration of chain (whipping)	Chain too slack	Adjust to a proper sag. Consider the installation of spring type idler or tensioner.
	Uneven wear elongation	Imperfect and uneven lubrication causes uneven wear and pitch irregularity. Immediately replace the chain with a new one, and practice perfect and uniform lubrication.
	Occurrence of stiff link	See the following column
Stiff link	Load in excess of tolerance	Select a DID chain larger in tolerance.
	Misalignment of sprockets	If the alignment between sprockets is incorrect, the force acting on the sprockets on their lateral sides opens and causes inner plates to interfere with the outer plates, which causes stiff links. Correctly align the larger and smaller sprockets.
	Corrosion of chain Improper lubrication	If a chain is left without lubrication for a long time or in a corrosive atmosphere, rust is generated and smooth motion is inhibited. A corroded chain must be replaced. Be sure to lubricate periodically.
	Interference between plate and foreign matter	If a chain is in contact with foreign matter during running, the inner and outer plates may be opened. Immediately remove the foreign matter.
	Ingress of foreign matter into a bendable portion of chain.	If sand or mud enters a bendable portion, remove the chain, and wash and re-lubricate, or replace the chain. Furthermore, install a case, etc. to prevent the ingress of sand and mud.
Fractured chain	Fatigue fracture	If a chain is used for a long time at a load exceeding the maximum allowable tension, fatigue fracture of plates and bending fatigue fracture of pins will occur. If the life before fatigue fracture is shorter than the expected life, select a chain with a larger maximum allowable tension. For example, if a DID50 Standard Roller Chain, is used for 750 cc motor-cycles, it may be fractured in a short time. In this case, rather than the chain being faulty, the selection was incorrect.
	Ductile fracture of plates Fracture of pins by shear of bending	If a load or shock load is greatly larger than the allowable tension acts on a chain, ductile fracture of plates or fracture of pins by shear or bending occurs. This fracture occurs when the chain size selected is incorrect and allowable tension too small. Re-select a proper chain.
Note : See "Fracture patterns of respective components of chain " on P. 79.	When the chain rides over a sprocket	The fracture caused when the chain rides over a sprocket is mainly caused by wear elongation. Select a proper chain, and practice correct lubrication.
	Hydrogen embrittlement	Remember that a chain might be broken suddenly by hydrogen embrittlement if it comes in contact with acids.
	Interference with foreign matter	If foreign objects should interfere with the running of chain or be caught, the chain is likely to be over loaded and its life will be shortened or it may break suddenly. Watch the shop atmosphere carefully, and be sure to remove any foreign objects without delay.
Rotation of pin (see P. 79)	Excessive tension Riding of chain over sprocket Corrosion of chain and improper lubrication	If excessive tension is a cause, select a chain larger in allowable tension. See the column "When the chain rides over a sprocket". See the third frame of "Stiff link".

Fracture patterns of respective components of chain

When a roller chain is broken during operation due to improper use, knowing how and what portion is broken greatly helps to clarify the cause and determine corrective measures.

Fracture of plates

When a large tension acts to fracture a plate, as shown in (a), the cut ends are oblique and plastic deformation occurs.

However, when the load is slightly larger than the maximum allowable tension, fatigue fracture occurs, and little plastic deformation occurs as shown in (b). A large feature of fatigue fracture is when a crack occurs in the direction almost perpendicular to the pitch line (center line between both pins).

In the case of hydrogen embrittlement by an acid, the crack mostly occurs in the direction as shown in (c), and the cut ends are flat, while the area around the cut ends may be decolorized due to erosion by the acid.

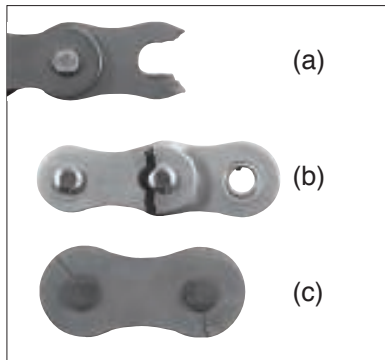

Fracture of pins

If a pin is fractured by excessive tension, the fracture occurs near the link plate, with a lustrous finished surface formed by shearing, as shown in (d). However, when the acting force is not so strong, fatigue fracture takes place after a long period around the center of the pin as shown in (e) then supposed to be flat with small undulations.

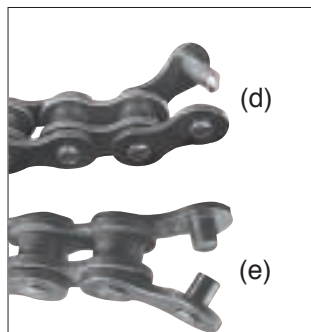

Fracture of bushings

A bushing is fractured by a shock, in a way similar to a roller. Generally, as shown in the photo, a vertical crack occurs and stops near the plates. One crack can also be superimposed on another, causing the central portion to come off. In general, it can be said that a larger crack is caused by a larger tension.

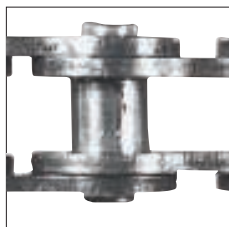

● Fracture of rollers

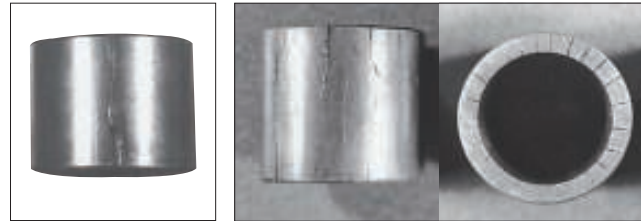

When a roller fractures during operation, generally vertical splitting occurs as shown in the photo, and in general, pitch marks of fatigue grow from the inside of the roller, to cause splitting. If splitting occurs all at once due to a large tension, the split faces do not have a polishing mark to allow the cause to be identified.

If tension is excessive, the rollers are forcefully pressed against the tooth faces of sprockets, and a roller end may be cracked and deformed.

● Rotation of pins

As shown in the photo, the rotation of a pin can be identified since the rivet mark on the pin head shifts from the correct position. If the chain is disassembled, galling is found between a pin and bushing in most cases. The cause of galling is incorrect lubrication or excessive tension. In the case of a machine not used for a long time, rust may develop between pins and bushings, causing the pin to rotate.

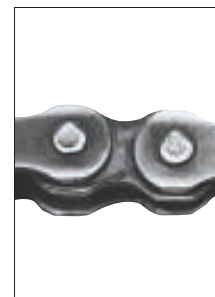

Elongation of chain

In general, the elongation of chain includes the following three types;

1. Elastic elongation by chain tension
If a load acts on a chain, the respective components of the chain are elastically deformed, causing elongation. If the load is removed, the original length can be restored.
2. Plastic elongation by chain tension
If a load in excess of the elastic limit acts on a chain, plastic elongation occurs. In this case, even if the load is removed, the original length cannot be restored. The performance of a plastically elongated chain may be diminished. Quickly replace it with a new one.
3. Wear elongation of chain
If a chain is operated, pins and bushings are worn through by mutual contact. After use for a long time, the wear appears as an increase of chain length. This is wear elongation. Wear elongation is an important factor for deciding the timing of chain replacement. See P. 73.

5-5 Timing for Replacement

If the engagement between chain and sprockets becomes defective or any factor occurs which remarkably promotes a decline in the strength of the chain, replace the whole chain. When any of the following conditions occur in the chain you use, replace the whole chain to maintain safety.

- When a replace chain is worn close to the "Elongation limit of chain" (P. 79)
 - When a flaw or crack occurs in a plate
 - When a flaw or crack or defective rotation of a roller is observed
 - When a chain link is stiff
 - When a pin has been rotated
 - When a pin is bent or otherwise deformed or when a plate is seriously warped
 - When rust buildup prevents smooth bending of the chain
 - When diluted sulfuric acid or any other corrosive material is deposited
- * If you cannot judge whether a flaw is "harmful", please consult us.

Replacement of sprockets and how to order

The life of sprockets is generally several times the life of a chain, but if the teeth are worn because of insufficient lubrication or damaged because of a shock load, etc., the sprockets must be replaced.

- When placing an order, please specify the following if the chain No. is known.
 1. Chain No. and number of strands
 2. Type of sprockets
 3. Prepared shaft hole diameter (d) (This is not necessary if you drill this hole; in this case, drill a hole not exceeding the maximum shaft hole diameter.)
 4. Number of teeth
 5. Boss diameter (DH) and length (L) (in the case of other than standard sprocket)
 6. Whether the tooth heads are hardened
- Specify the following items, if the chain No. is unknown
 1. Tooth thickness (T)
 2. Root diameter (DB) (Caliper diameter (DC) in the case of odd - numbered teeth)

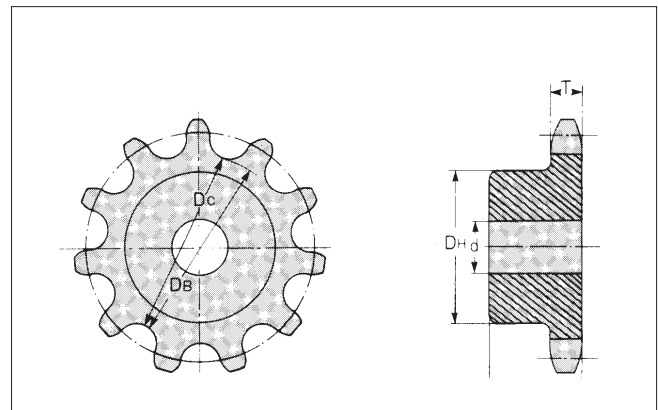

Roller Chain & Double Pitch Chain for Conveyor Applications

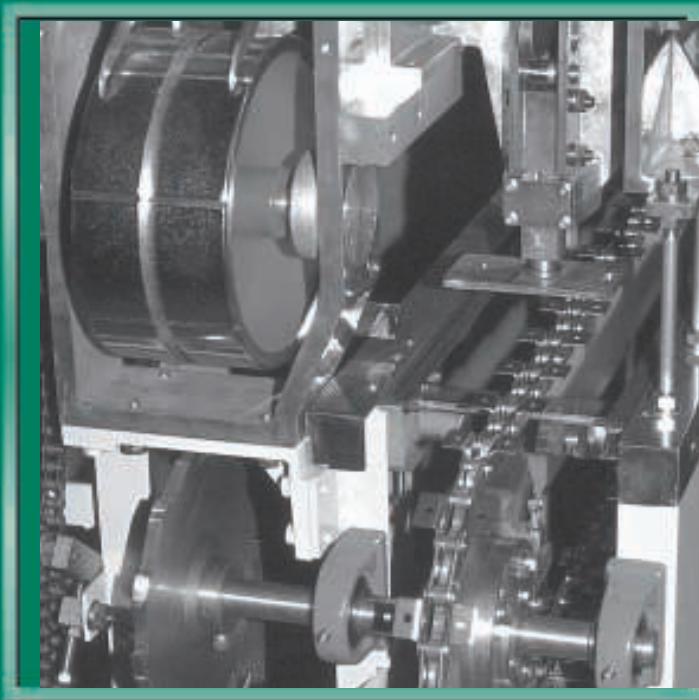

1. Outline of DID Small Chain for Conveyor Applications

1-1 Variation of base chain

DID Small Sized Roller Chain for Conveyor Systems are called base chain, and include single pitch chain and double pitch chain.

Single pitch chain correspond to Section 2 “General application chain” in the previous chapter of “Transmission chain”, and are used with “JIS/ANSI standard sprockets”.

Double pitch chain are standardized as “JIS/ANSI Double Pitch Chain”, and the design of pins, bushings and rollers are basically the same as that of “single pitch chain”. The plates only are made longer to make the pitch double that of single pitch. The sprockets of double pitch rollers are also standardized as “JIS/ANSI double pitch chain sprockets”.

Small Sized Roller Chain for Conveyor Systems are based on the above base chain, and have various top rollers, side

rollers and attachments that customize chain for different applications. Classifications of DID Small Sized Roller Chain for Conveyor Systems are shown below.

1-2 Ultimate Life Chain Series and Environment Resistant Chain Series

The “2-3 Ultimate Life Chain Series and “2-4 Environment Resistant Chain Series” described in the previous chapter, “Transmission chain”, are also available in Small Sized Roller Chain for Conveyor Applications. Chain in the Small Sized Roller Chain for Conveyor Applications Series are listed on the following page for reference.

Classification

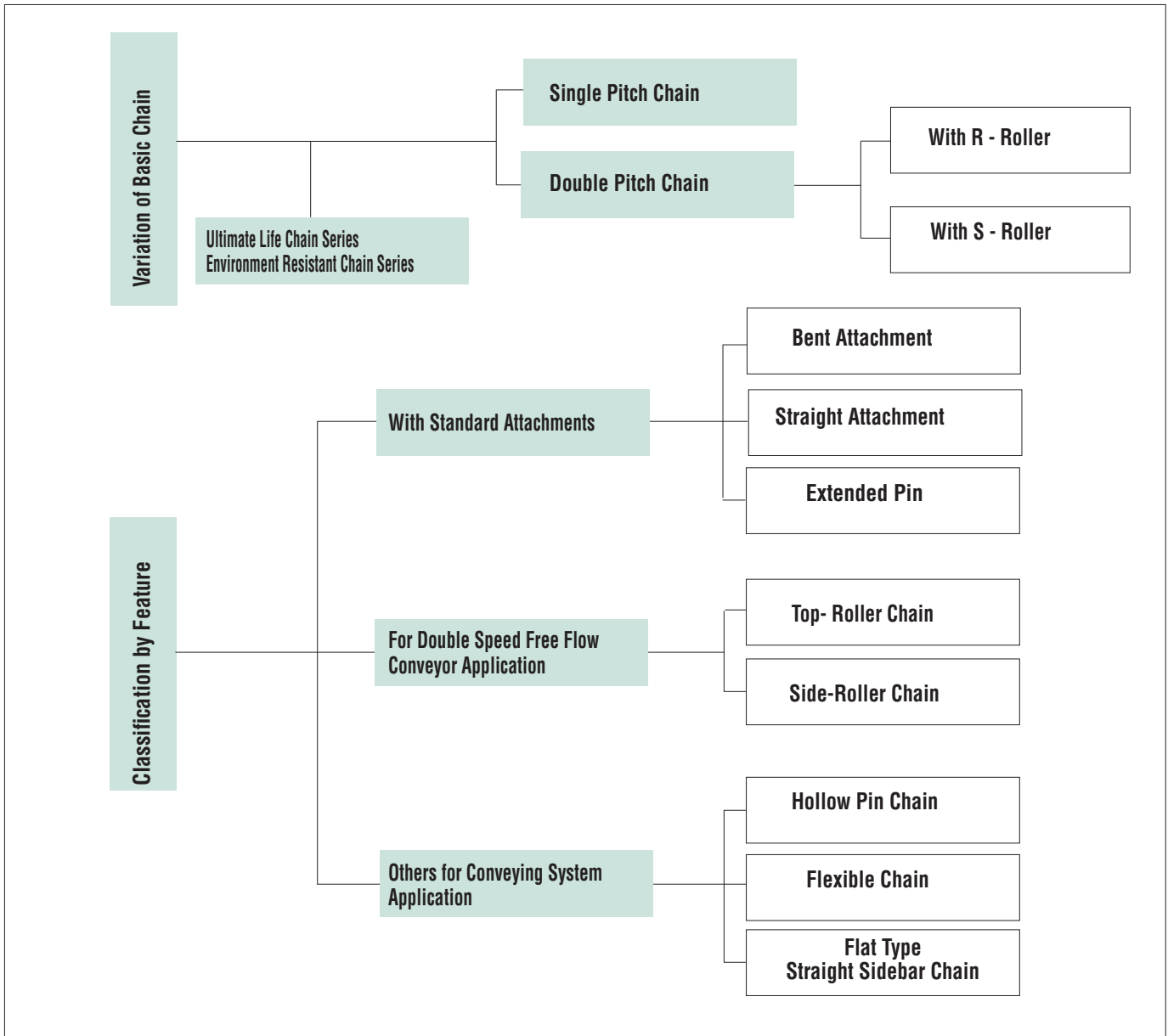

List of small chain for convey or systems (Ultimate Life Series and Environment Resistant Series)

Ultimate Reistant Series		Type of chain (for both single pitch and double pitch)									
		Standard chain					O-ring chain		Stintered bushing roller chain		
Environment Resistant Series		Size classified table	Regular	Solid Bushing	Rustless	Hi-guard	Stainless	Regular	Rustless	Regular	Rustless
Standard attachments		Table of P.126	0	0	0	0	0	0	0	0	0
Fortune flow	S2 chain	Table of P.134	0	-	-	-	-	-	-	-	-
	Top roller chain	"	0	0	0	-	-	0	0	0	0
	Side roller chain	"	0	0	0	-	-	0	0	0	0
Hollow pin chain		"	0	-	0	-	-	-	-	-	-
Flexible chain		"	0	0	0	-	-	-	-	-	-
Flat Type Roller chain		"	0	0	0	0	-	0	0	-	-

- Note 1 Standard sintered bushing roller chain is available for RC80 and smaller single pitch chain and for RC2080H and RC2082H and smaller double pitch chain.
- Note 2 Standard O-ring chain are available for RC240 and smaller single pitch chain and for RC2060H and RC2062H and smaller double pitch chain.
- Note 3 Standard Hi-guard chain are available for RC120 and smaller single pitch chain and RC2120H and RC2122H and smaller double pitch chain.
- Note 4 For stainless steel chain, see P.55.

1-3 How to order a small chain for conveyor applications

- When you order RC2050 with 96 links with K1 attachments (one hole) every other link with a connecting link attached to one end.

[Example]

RC 2050 K1 2 X 96 incl. 1 CL ATOE

Roller Chain

Chain Size





Attachment Spacing

Attachment Type

Chain Length

Description for Connecting Link

Indication of connecting link

		-- A connecting link is packed separately with the chain
JE:		-- Endless with a connecting link already installed
ATOE:		--- A connecting link is attached to one end
BERL:		-- No connecting link is to be included Both Ends Roller Link

Please provide descriptions for special arrangement.

* In case of top roller chain or side roller chain, see the pages for the chain concerned.

2. Double Pitch Chain

In general, Small Sized Roller Chain for Conveyor Applications are operated for longer distances and at lower speeds than transmission chain. In this case, even if the plate pitch is double with the pins, bushings and rollers unchanged, to half the number of teeth engaged with the sprockets, the wear of pins bushings and rollers is small since the chain speed is low, while the number overall is halved. DID Double Pitch Chain, conform to ANSI and are manufactured in "Ultimate Life Chain Series" and "Environment Resistant Chain Series," as are single pitch chain. Generally, sprockets for double pitch chain utilize single pitch type sprockets.

Connecting links

In the connecting links of double pitch chain of all sizes, the connecting plate and connecting pins are clearance-fitted. For RC2060H or smaller, the spring clip type (R connecting link) is standard. For RC2080H or larger, the cotter type (C connecting link) is standard. Connecting links with an attachment, top roller or side roller are available.

Large rollers (R) and small rollers (S)

Since double pitch chain are frequently used to travel on a horizontal floor, conveying products, chain designed for this purpose are equal in roller diameter to single pitch chain of the same pitch length for increased live load capacity and lower traveling resistance. The rollers larger in outer diameter are called "large rollers", and the regular rollers are called "small rollers". In this catalogue, large rollers are expressed as R rollers, and small rollers as S rollers.

Designation of Double Pitch Chain

A double pitch chain is designated, as in the following example, based on the nominal number of the basic single pitch chain.

[Example of type indications]

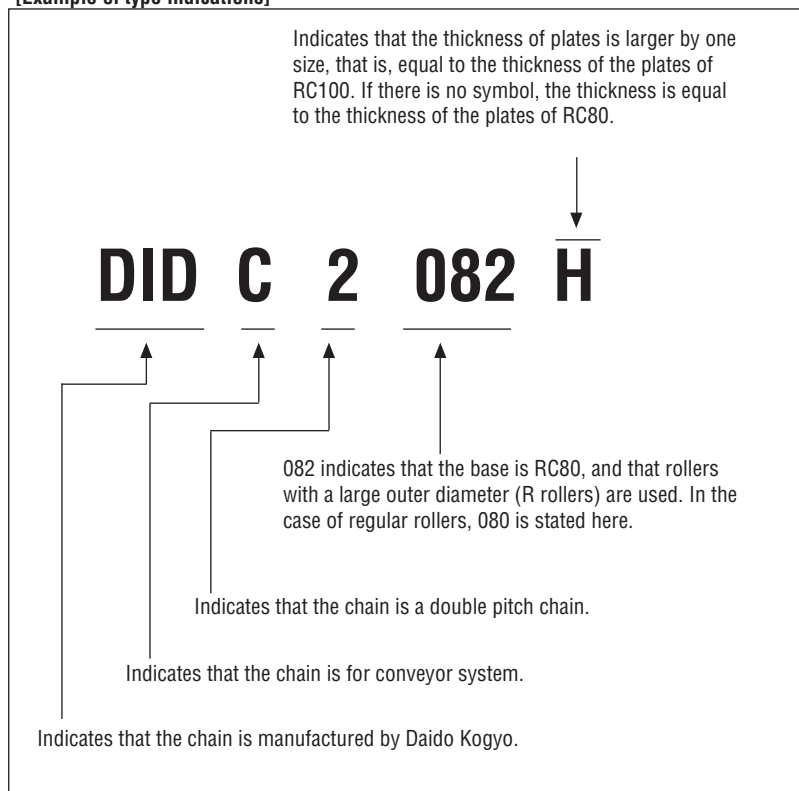

2-1 Double Pitch Chain and Dimensions

Double Pitch Chain

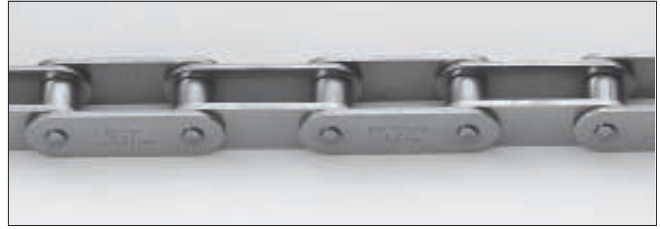

ROLLER CHAIN & DOUBLE PITCH CHAIN FOR CONVEYOR SYSTEM

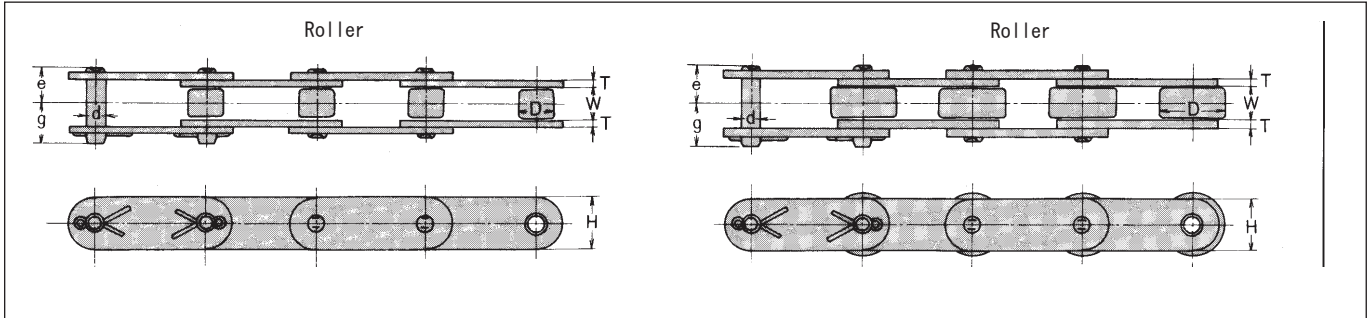

Chain No. DID	Pitch P	Roller Link Width W	Roller Dia. D	Pin			Plate		Avg. Tensile Strength lbs.	Max. Allowable Load lbs.	Approx. Weight lbs.
				d	e	g	T	H			
RC2040 RC2042	1.000	0.313	0.312 0.625	0.156	0.327	0.398	0.059	0.461	3828	594	0.329 0.577
RC2050 RC2052	1.250	0.375	0.400 0.750	0.200	0.402	0.476	0.079	0.594	6446	990	0.563 0.885
RC2060H RC2062H	1.500	0.500	0.469 0.875	0.235	0.563	0.669	0.126	0.677	9020	1452	0.972 1.455
RC2080H RC2082H	2.000	0.625	0.625 1.125	0.313	0.713	0.811	0.157	0.917	15400	2530	1.650 2.367
RC2100H RC2102H	2.500	0.750	0.750 1.562	0.376	0.858	0.961	0.189	1.134	25300	4180	2.414 3.896
RC2120H RC2122H	3.000	1.000	0.875 1.750	0.437	1.067	1.177	0.220	1.331	35200	5720	3.413 5.425
RC2160H RC2162H	4.000	1.250	1.125 2.250	0.563	1.339	1.504	0.280	1.866	58300	9460	5.975 9.120

Double pitch chain with resin rollers

This is a DID double pitch chain with R rollers made of a resin, which are quieter and lighter than steel rollers. Thus, the chain is suitable for a conveyor system designed to operate quietly and convey light-weight articles. Since the components other than rollers are made of steel, the average tensile strength of a resin roller chain is the same as that of a steel roller chain. However, if the engagement pressure with the sprockets risks damaging the resin rollers, the “maximum allowable load” of the chain is kept low, as shown in the following table. The “Allowable load of resin rollers” refers to the allowable load acting when conveyed articles press the resin rollers traveling on the floor surface.

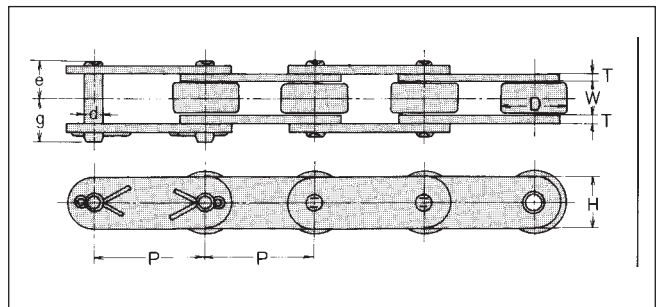

Chain No. DID	Material of Roller	Variation of Chain Components except Roller	Max. Allowable Load	Max. Allowable Load of Plastic Roller	Weight (lbs/FT)	Allowable Operational Temperature
			lbs	lbs		
RC2042	Engineering Plastic (Polyacetal)	3 Variations are available. • Standard Steel • Rustless Type (Nickel Plated) • Stainless Steel	99	44	0.51	- 10°C~80°C (14°F~176°F)
RC2052			154	66	0.85	
RC2062H			231	110	1.46	
RC2082H			396	198	2.58	

2-2 DID Ultimate Life Chain and Environment Resistant Chain Series of Double Pitch Chain

Double pitch chain are manufactured in Ultimate Life and Environment Resistance types, as are chain for general applications.

For details of their characteristics, see Chapter I (P. 42-51).

Environment Resistant Chain Series	
Sealed chain	The width of the chain is larger than a standard double pitch chain by the seal thickness. (See the following table of maximum half widths of chain.)
Sintered bushing roller chain	Dimensions are the same as those of a standard chain, but strength is lower.

Environment Resistant Chain Series	
Long life chain Rustless chain Hi-guard chain	Strength and dimensions are equivalent to those of a standard double pitch chain.
Stainless steel chain	Dimensions are the same but strength is lower. (See the following table.)

	Maximum half width of chain	
	Regular chain (Dimension g)	Sealed chain (Dimension f)
RC2040 RC2042	0.398	0.417
RC2050 RC2052	0.476	0.500
RC2060H RC2062H	0.669	0.705
RC2080H RC2082H	0.811	0.00
RC2100H RC2102H	1.177	0.00
RC2120H RC2122H	1.504	0.00

	Maximum allowable load			
	Regular chain		Stainless steel chain	
	kN	lbs	kN	lbs
RC2040 RC2042	2.64	594	0.44	99
RC2050 RC2052	4.41	990	0.68	154
RC2060H RC2062H	6.47	1452	1.03	231
RC2080H RC2082H	11.20	2530	0.00	0
RC2100H RC2102H	18.60	4180	0.00	0
RC2120H RC2122H	25.50	5720	0.00	0

Comparison of performance of respective types of Ultimate Life Chain

	Strength ratio	Comparison of wear life				Operational temperature range
		Location where maintenance can be practiced		Location where maintenance cannot be practiced (initial grease only)		
		Clean oil	Dirty oil	Regular environment	Dusty environment	
Standard Chain	100%	1-0	1-0	1-0	1-0	14°C ~ 176°F
Long life Chain	100%	1-3	1-2 ~ 1.5	1-5 ~ 3	1-8 ~ 4	14°C ~ 176°F
DHA Chain	100%	1.5 ~ 2	3 ~ 7	1.3	1.2 ~ 3	14°C ~ 212°F
Sealed Chain	100%	—	—	5 ~ 12	5 ~ 20	14°C ~ 140°F
Sintered bushing roller chain	70%	—	—	5	Not applicable	Not applicable

Note: The wear life is expressed as an index with the life of a Standard Roller Chain as 1.0.

Comparison of performance of respective types of Environment Resistant Chain

Series	Mark	Strength		Moisture Resistance Performance (without additional lubrication)		Corrosion Resistance Performance				
		Max. Allowable Load Ratio	Chain Selecting Method	Initial Lubricant Applied		Based on CASS test	Exposed to water or sea water	Alkaline Resistance Performance	Acid Resistance Performance	Heat Resistance Performance
Standard Roller Chain	—	100%	Max. Horsepower Ratings or Slow-Speed Selection	Rust Prevention Oil	inferior	inferior	not recommended	normal	not recommended	-10°C~80°C (14°F~176°F)
				Grease	normal	normal (note)				
Rustless Chain	N	100%		Rust Prevention Oil	inferior	good (note)	good	excellent	Applicable in light acid	Layer withstands up to 250°C (482°F)
				Grease	normal	very good				
Hi-Guard Chain	E	100%		Rust Prevention Oil	inferior	excellent	excellent	normal	not recommended	Layer withstands up to 250°C (482°F)
				Grease	normal					
Low Temperature Chain	TK	100%		Special Grease	normal	normal	not recommended	normal	not recommended	-40°C~80°C (40°F~176°F)
Stainless Steel Chain	SS	10%		Slow-Speed Selection	Stainless Chain is inferior to others in wear resistance performance. Chain tension must be within allowable range.					
	SSK	15%								

Note: Even rustless chain, RC25N, 35N and 41N should be read from "good" to "normal" and "excellent" to "good" because of the thin plating layer.

ROLLER CHAIN & DOUBLE PITCH CHAIN FOR CONVEYOR SYSTEM

3. Standard Attachments

For "DID small sized roller chain for conveyor applications", various links are available for coupling and attaching custom devices directly to the chain. These links are called attachments. The following standard attachments are available.

Types and names of standard attachments

DID Standard Attachments include five kinds for single pitch chain and five kinds for double pitch chain as illustrated below. Furthermore, for single pitch chain, four kinds of wide attachments, as wide as outer plates are available. Standard attachments for respective chain sizes are listed on the following page

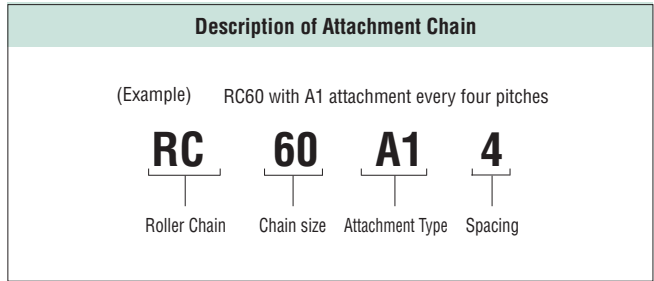

ROLLER CHAIN & DOUBLE PITCH CHAIN FOR CONVEYOR SYSTEM

A attachment (Bent attachment on one side)

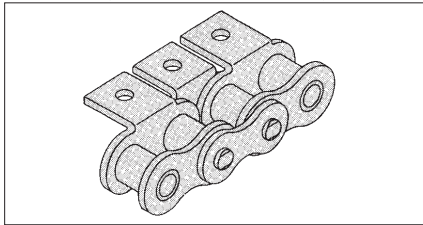

SA(M35) attachment (Straight attachment on one side)

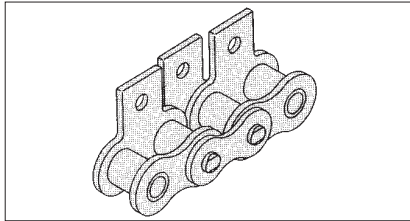

D1 Attachment (Extended Pin)

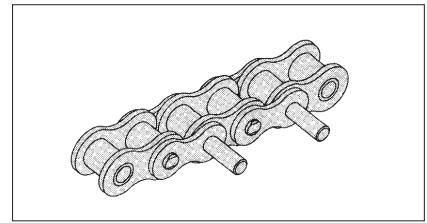

Above figure shows D1 (set and extended pin on every two links)

K attachment (Bent attachment on both side)

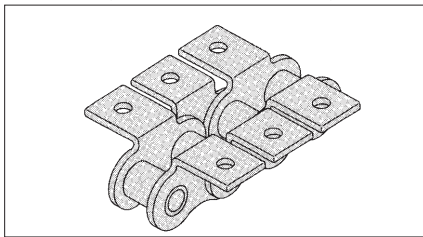

SK(M) attachment (Straight attachment on both sides)

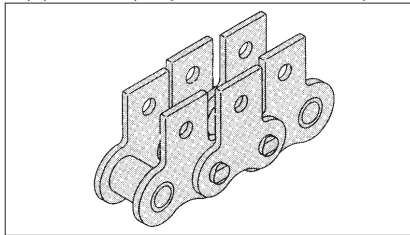

D3 Attachment (Extended Pin)

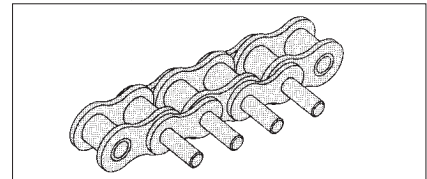

Above figure shows D3 (set an extended pin on every two link)

[Ref : D pin having particular length is called "LP attachment" (Abbreviation of Long Pin)]

Example of Use of Standard Attachment

<p>Installation of a U slot with SK1(M1) attachment</p>	<p>Installation of a dog with SK1(M1) attachment</p>	<p>Installation of a pins with K1 attachment</p>	<p>Installation of a bucket with K1 attachment</p>	<p>Installation of a bucket with K1 attachment</p>
<p>Installation of a strut with A1 attachment</p>	<p>Conveyance of long article by two strands of SA1(M351) attachment</p>	<p>Installation of a L metal fitting with D3 attachment</p>	<p>Installation of a dog with D1 attachment</p>	

3-1 Standard Roller Chain Attachments

O Available in stock
 Δ Made-to-Order
 X Special

		DID Standard Attachment																	
		Normal Type									Wide Type								
		One-side Bent		Both-Sides Bent		One-side Straight Type		Both-sides Straight Type		Extended Pin		One-side Bent		Both-Sides Bent		One-side Straight Type		Both-sides Straight Type	
		A1	A2	K1	K2	SA1	SA2	SK1	SK2	D1	D3	WA1	WA2	WK1	WK2	WSA1	WSA2	WSK1	WSK2
Single pitch	RC25	0	X	0	X	0	X	0	X	Δ	Δ								
	RC35	0	X	0	X	0	X	0	X	Δ	Δ								
	RC41	Δ	X	Δ	X	Δ	X	Δ	X	X	X								
	RC40	0	X	0	X	0	X	0	X	Δ	Δ	Δ	Δ	Δ	Δ	Δ	Δ	Δ	
	RC50	0	X	0	X	0	X	0	X	Δ	Δ	Δ	Δ	Δ	Δ	Δ	Δ	Δ	
	RC60	0	X	0	X	0	X	0	X	Δ	Δ	Δ	Δ	Δ	Δ	Δ	Δ	Δ	
	RC80	0	X	0	X	0	X	0	X	Δ	Δ	Δ	Δ	Δ	Δ	Δ	Δ	Δ	
	RC100	0	X	0	X	0	X	0	X	Δ	Δ	Δ	Δ	Δ	Δ	Δ	Δ	Δ	
	RC120	0	X	0	X	0	X	0	X	Δ	Δ	X	X	X	X	X	X	X	X
	RC140	0	X	0	X	0	X	0	X	Δ	Δ								
RC160	0	X	0	X	0	X	0	X	Δ	Δ									
RC200	Δ	X	Δ	X	Δ	X	Δ	X	Δ	Δ									
RC240	Δ	X	Δ	X	Δ	X	Δ	X	X	X									
Double pitch	"S" roller	RC2040	0	0	0	0	0	0	0	0	Δ	Δ							
		RC2050	0	0	0	0	0	0	0	0	Δ	Δ							
		RC2060H	0	0	0	0	0	0	0	0	Δ	Δ							
		RC2080H	0	0	0	0	0	0	0	0	Δ	Δ							
		RC2100H	0	0	0	0	0	0	0	0	Δ	Δ							
	"R" roller	RC2120H	0	0	0	0	0	0	0	0	Δ	Δ							
		RC2120H	0	0	0	0	0	0	0	0	Δ	Δ							
		RC2042	0	0	0	0	0	0	0	0	Δ	Δ							
		RC2052	0	0	0	0	0	0	0	0	Δ	Δ							
		RC2062H	0	0	0	0	0	0	0	0	Δ	Δ							
RC2082H	0	0	0	0	0	0	0	0	Δ	Δ									
RC2102H	0	0	0	0	0	0	0	0	Δ	Δ									
RC2122H	0	0	0	0	0	0	0	0	Δ	Δ									
RC2162H	0	0	0	0	0	0	0	0	Δ	Δ									

How to Indicate The Specially Arranged Attachment Chain

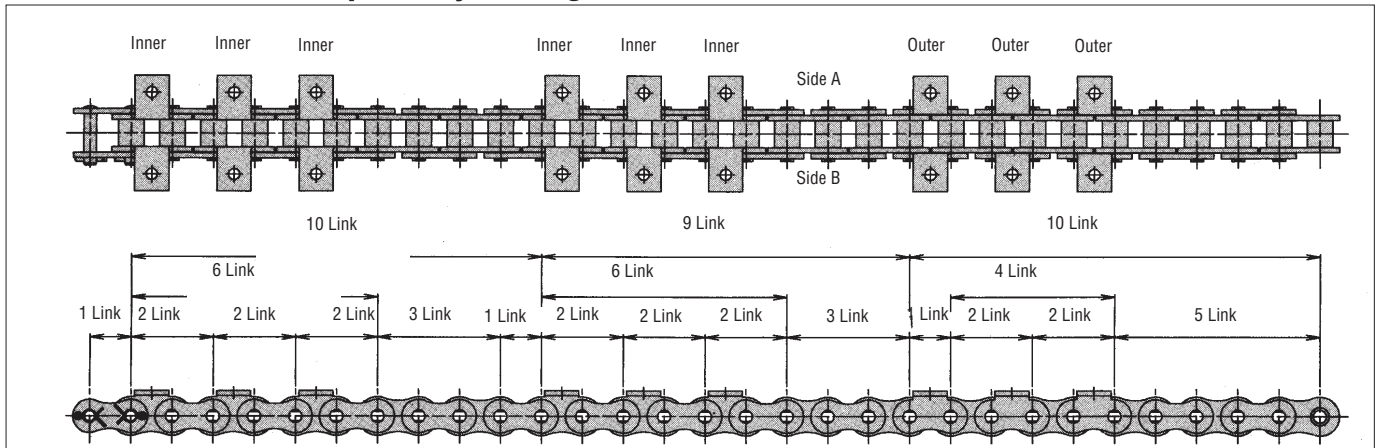

A chain with K1 attachments specially arranged, as in the above illustration, is indicated as follows:

$$CL + (K1 \text{ inner} + PL) X3 + 3LL + PL + (K1 \text{ inner} + PL) X + 3 + 3LL + K1 \text{ outer} + (RL + K1 \text{ outer} X2 + 5LL)$$

"CL" stands for a connecting link; "K1 inner", an inner link K1 attachment; "PL", an outer link; "3LL", three links from an inner link to an inner link; "K1 outer", an outer link K1 attachment; and "RL", an inner link. A "+" sign means "connect", and an "x" sign means "repeat" (For one-side attachments such as A attachment and SA attachment, the position of attachment plates is on side A in the above illustration.)

ROLLER CHAIN & DOUBLE PITCH CHAIN FOR CONVEYOR SYSTEM

3-2 Based on Standard Chain (single pitch)

A chain with attachments is installed on a Standard Roller Chain for a light weight conveyor system. Use this chain when exceptional highly accurate conveyance is required or when a compact layout is desired.



ROLLER CHAIN & DOUBLE PITCH CHAIN FOR CONVEYOR SYSTEM

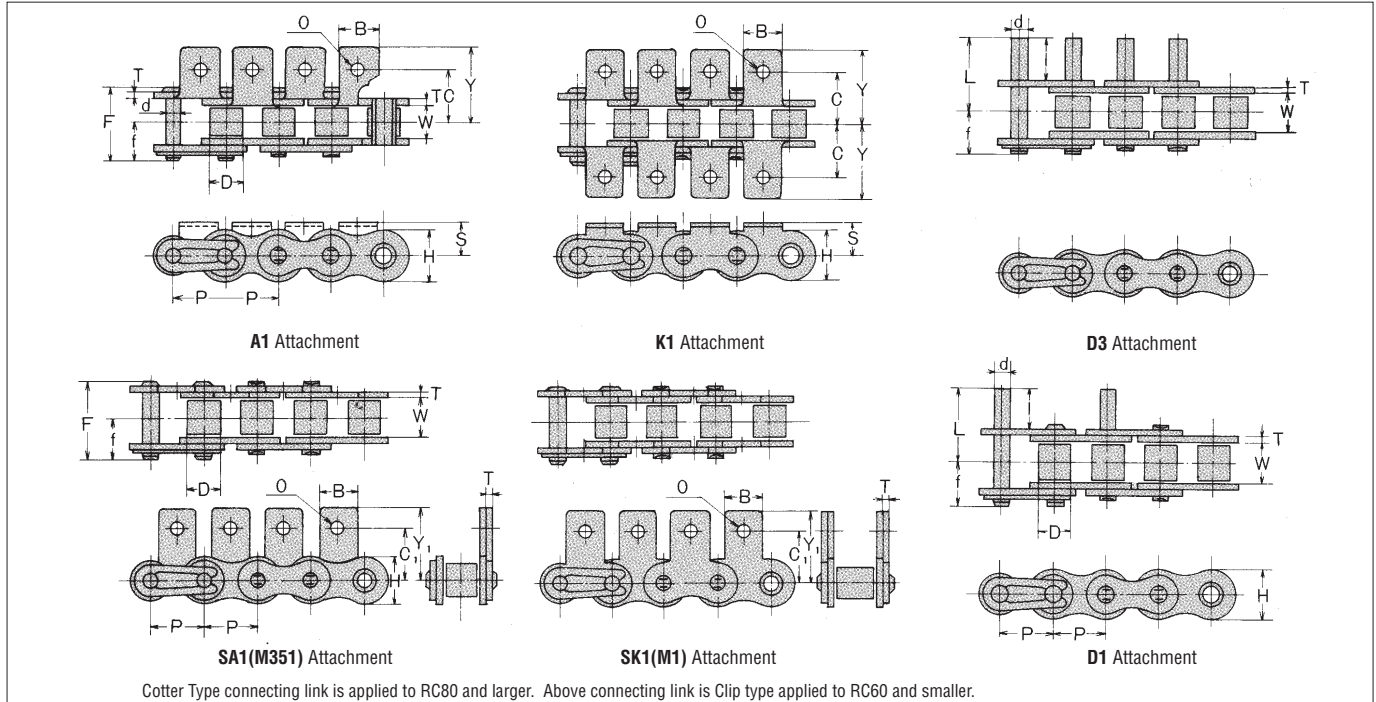

Cotter Type connecting link is applied to RC80 and larger. Above connecting link is Clip type applied to RC60 and smaller.

Chain No. DID	Pitch P	Roller Link Width W	Roller (Bush) Dia. D	Pin			Plate		Avg. Tensile Strength lbs.	Max. Allowable Load lbs.	Approx. weight without attachment (lbs/FT)
				d	F	f	T	H			
RC25	0.250	0.125	0.130	0.091	0.335	0.185	0.028	0.232	902	143	0.087
RC35	0.375	0.188	0.200	0.141	0.516	0.287	0.049	0.354	2090	330	0.215
RC41	0.500	0.251	0.306	0.141	0.575	0.311	0.047	0.378	2266	374	0.262
RC40	0.500	0.313	0.312	0.156	0.693	0.374	0.059	0.472	3740	594	0.422
RC50	0.625	0.375	0.400	0.200	0.862	0.457	0.079	0.591	6270	990	0.711
RC60	0.750	0.500	0.469	0.235	1.059	0.563	0.094	0.713	9020	1430	0.966
RC80	1.000	0.625	0.625	0.313	1.394	0.748	0.126	0.945	17600	2420	1.790
RC100	1.250	0.750	0.750	0.376	1.673	0.894	0.157	1.177	26620	3850	2.676
RC120	1.500	1.000	0.875	0.437	2.087	1.110	0.189	1.413	37400	5500	3.909
RC140	1.750	1.000	1.000	0.500	2.299	1.248	0.220	1.650	48400	7260	5.110
RC160	2.000	1.250	1.125	0.563	2.685	1.437	0.252	1.882	60500	9240	6.766
RC200	2.500	1.500	1.562	0.781	3.346	1.811	0.315	2.362	105600	15400	11.279

Unit (inch)

Chain No. DID	Pitch P	A1, K1 Attachment			SA1, SK1 Attachment		Common Dimensions		D1, D3 Attachment		Approx. additional weight per attachment (kg)		
		C	Y	S	C1	Y1	B	O	I	L	A, SA	K, SK	D1, D3
RC25	0.250	0.281	0.421	0.187	0.313	0.461	0.219	0.134	0.236	0.362	0.001	0.001	0.000
RC35	0.375	0.375	0.563	0.250	0.375	0.579	0.313	0.134	0.375	0.569	0.002	0.004	0.002
RC41	0.500	0.469	0.689	0.281	0.484	0.701	0.375	0.128	0.375	0.618	0.003	0.007	0.002
RC40	0.500	0.500	0.709	0.312	0.500	0.693	0.375	0.142	0.375	0.648	0.004	0.009	0.002
RC50	0.625	0.625	0.902	0.406	0.625	0.890	0.504	0.205	0.469	0.827	0.007	0.013	0.004
RC60	0.750	0.750	1.091	0.469	0.719	1.039	0.634	0.205	0.562	1.020	0.013	0.026	0.007
RC80	1.000	1.000	1.386	0.625	0.969	1.341	0.750	0.268	0.750	1.335	0.024	0.048	0.015
RC100	1.250	1.250	1.748	0.781	1.250	1.709	1.000	0.343	0.938	1.638	0.053	0.106	0.026
RC120	1.500	1.500	2.161	0.906	1.437	2.031	1.125	0.413	1.125	2.000	0.081	0.163	0.044
RC140	1.750	1.750	2.437	1.125	1.750	2.437	1.375	0.500	1.312	2.250	0.150	0.299	0.066
RC160	2.000	2.000	2.811	1.250	2.000	2.752	1.500	0.563	1.500	2.614	0.200	0.400	0.099
RC200	2.500	2.500	3.543	1.688	2.500	3.327	1.874	0.669	1.875	3.283	0.409	0.818	0.233

Unit (inch)

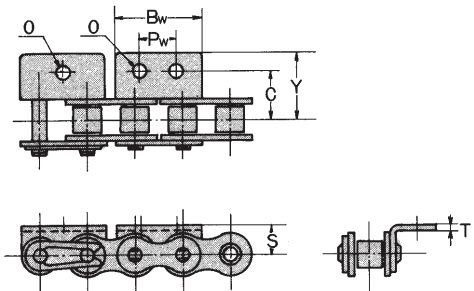

WA1, WA2 Attachment

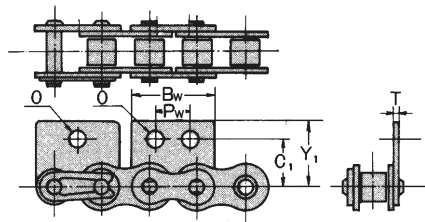

WSA1 (WM351), WSA2 (WM352) Attachment

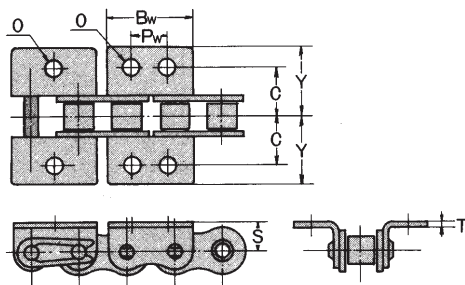

WK1, WK2 Attachment

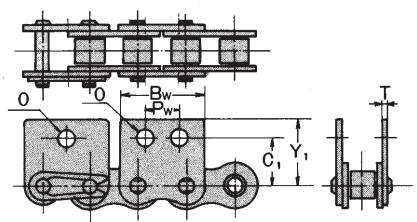

WSK1 (WM1), WSK2 (WM2) Attachment

Cotter Type connecting link is applied to RC80 and larger. Above connecting link is Clip type to be applied to RC60 and smaller.

Unit (inch)

Chain No.	Pitch P	Attachment									Approx. additional weight per attachment (lbs)	
		C	C1	O	S	T	Y	Y1	Bw	Pw	WA, WSA (WM352)	WK, WSK (WM)
RC40	0.500	0.500	0.500	0.142	0.311	0.059	0.689	0.689	0.953	0.500	0.007	0.013
RC50	0.625	0.626	0.626	0.205	0.406	0.079	0.890	0.890	1.189	0.625	0.015	0.031
RC60	0.750	0.750	0.720	0.205	0.469	0.094	1.063	1.031	1.421	0.750	0.026	0.053
RC80	1.000	1.000	0.969	0.268	0.626	0.126	1.390	1.343	1.890	1.000	0.057	0.114
RC100	1.250	1.250	1.252	0.327	0.780	0.157	1.906	1.870	2.358	1.250	0.112	0.224

Based on Standard Chain (double pitch)

A double pitch chain for a conveyor system is a Standard Roller Chain doubled in pitch. Since the pins and bushings are the same as those used in a Standard Roller Chain, the chain is strong, light weight and economical. A double pitch conveyor chain is available either as S roller type or R roller type. By installing attachments suitable for the application, a compact conveyor layout can be achieved.

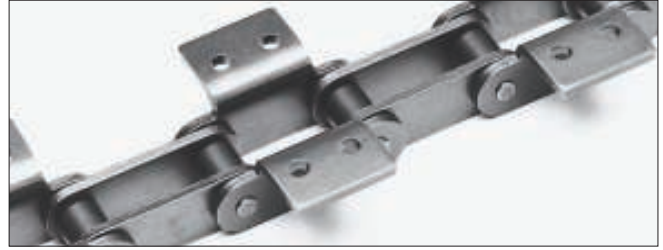

ROLLER CHAIN & DOUBLE PITCH CHAIN FOR CONVEYOR SYSTEM

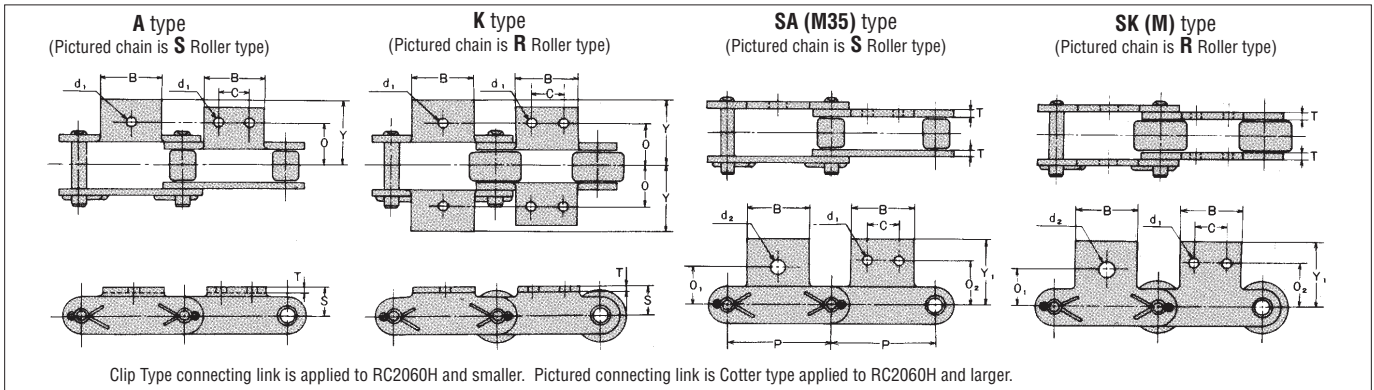

Chain No. DID	Pitch P	Roller Link Width W	Roller Dia. D	Pin			Plate		Avg. Tensile Strength	Max. Allowable Load	Unit (inch)
				d	e	g	T	H	lbs.	lbs.	Approx. weight without attachment (lbs/FT)
RC2040 RC2042	1.000	0.313	0.312 0.625	0.156	0.327	0.374	0.059	0.461	3828	594	0.329 0.577
RC2050 RC2052	1.250	0.375	0.400 0.750	0.200	0.402	0.457	0.079	0.594	6446	990	0.563 0.885
RC2060H RC2062H	1.500	0.500	0.469 0.875	0.235	0.567	0.669	0.126	0.677	9020	1452	0.972 1.455
RC2080H RC2082H	2.000	0.625	0.625 1.125	0.313	0.713	0.811	0.157	0.917	15400	2530	1.650 2.367
RC2100H RC2102H	2.500	0.750	0.750 1.562	0.376	0.858	0.961	0.189	1.134	25300	4180	2.414 3.896
RC2120H RC2122H	3.000	1.000	0.875 1.750	0.437	1.063	1.177	0.220	1.331	35200	5720	3.413 5.425
RC2160H RC2162H	4.000	1.250	1.125 2.250	0.563	1.354	1.504	0.280	1.866	58300	9460	5.975 9.120

Dimensions of Attachment

Chain No. DID	Pitch P	Attachment											Approx. additional weight per attachment (kg)	
		S	O	Y	Y1	O1	O2	C	B	d1	d2	T	A, SA	K, SK
RC2040 RC2042	1.000	0.359	0.500	0.748	0.780	0.437	0.531	0.375	0.780	0.142	0.205	0.059	0.0066	0.0132
RC2050 RC2052	1.250	0.437	0.625	0.949	0.969	0.563	0.625	0.469	0.937	0.205	0.268	0.079	0.0132	0.0264
RC2060H RC2062H	1.500	0.578	0.844	1.236	1.205	0.687	0.750	0.563	1.134	0.205	0.343	0.126	0.0352	0.0704
RC2080H RC2082H	2.000	0.750	1.094	1.642	1.630	0.875	1.000	0.750	1.500	0.268	0.406	0.157	0.0748	0.1496
RC2100H RC2102H	2.500	0.937	1.313	2.055	2.087	1.125	1.250	0.937	1.874	0.343	0.563	0.189	0.1408	0.2816
RC2120H RC2122H	3.000	1.094	1.563	2.390	2.362	1.313	1.485	1.125	2.252	0.551	0.630	0.220	0.2376	0.4752
RC2160H RC2162H	4.000	1.437	2.063	3.110	3.094	1.750	2.000	1.500	3.000	0.563	0.866	0.276	0.5412	1.0824

- Note: 1. Attachments SA1(M351), SK1(M1), A1 and K1 are featured by only one hole given. Attachments SA2(M352), SK2(M1), A2, and K2 are featured by two holes given.
 2. Interval of attachments must be specified when you order.
 3. Without special instruction, attachments are given to outer link plates in case of even number of pitch between attachments.

3-3 Based on O-ring Chain (single pitch)



Chain with attachments in which grease is sealed by seal rings are available as a series for use in the following cases.

- Machine service condition is likely to cause elongation of chain
- Machine cannot be lubricated during the service life
- Machine is used in an environment with water or dust

The hole pitch of attachments (the dimension in the following illustration) is the same as in the case of a Standard Roller Chain, DID standard sprockets can be used.

Heat resistant seal rings and light friction type seal rings are also available.

When you desire to use special attachments, please consult us.



ROLLER CHAIN & DOUBLE PITCH CHAIN FOR CONVEYOR SYSTEM

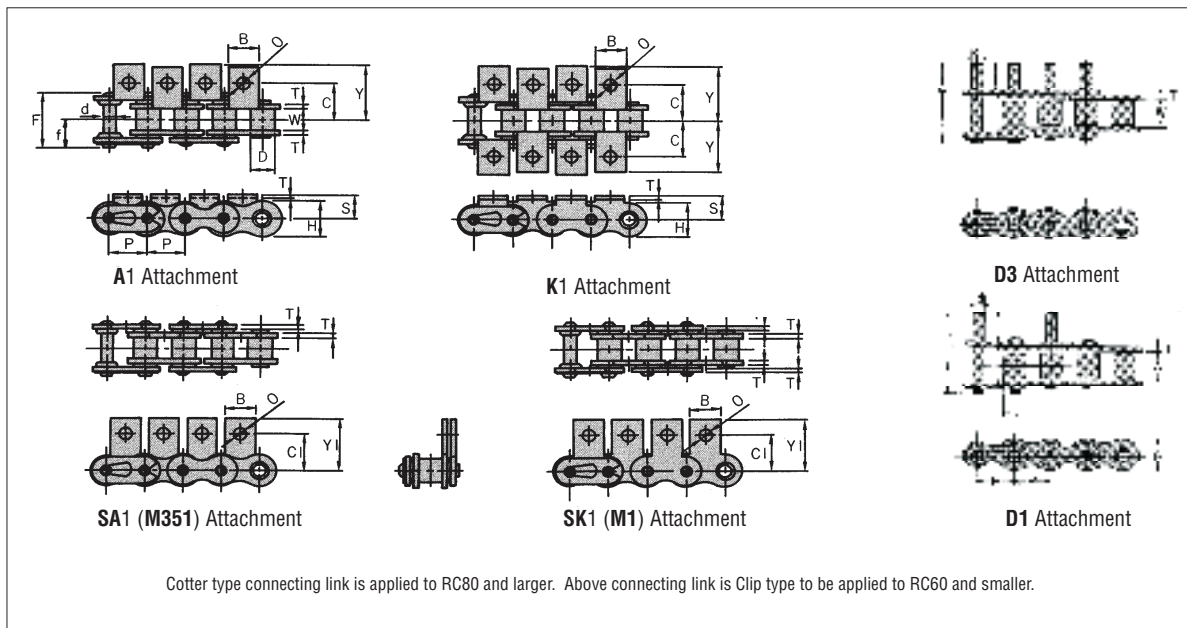

Unit (inch)

Chain No. DID	Pitch P	Roller Link Width W	Roller Dia. D	Pin			Plate		Avg. Tensile Strength lbs	Max. Allowable Load lbs	Approx. weight without attachment (lbs/FT)
				d	F	f	T	H			
RC40LLDR	0.500	0.313	0.312	0.156	0.787	0.417	0.059	0.472	4070	836	0.449
RC50LLDR	0.625	0.375	0.400	0.200	0.941	0.500	0.079	0.591	6754	1540	0.724
RC60LLDR	0.750	0.500	0.469	0.235	1.181	0.626	0.094	0.713	9614	2090	1.086
RC80LDR	1.000	0.625	0.625	0.313	1.531	0.819	0.126	0.945	16280	3300	1.898
RC100LDR	1.250	0.750	0.750	0.376	1.819	0.969	0.157	1.177	24200	4730	2.729

Dimensions of Attachment

Unit (inch)

Chain No. DID	Attachment									Approx. additional weight per attachment (lbs)		
	C	Y	S	C1	Y1	B	O	I	L	A, SA	K, SK	D1, D3
RC40LLDR	0.500	0.740	0.312	0.500	0.689	0.375	0.138	0.375	0.705	0.0044	0.0088	0.0022
RC50LLDR	0.625	0.969	0.406	0.625	0.890	0.500	0.205	0.469	0.870	0.0066	0.0132	0.0044
RC60LLDR	0.750	1.118	0.469	0.719	1.031	0.625	0.205	0.562	1.071	0.0132	0.0264	0.0066
RC80LDR	1.000	1.441	0.625	0.969	1.341	0.750	0.268	0.750	1.394	0.0242	0.0484	0.0154
RC100LDR	1.250	1.776	0.781	1.250	1.683	1.000	0.343	0.938	1.717	0.0528	0.1056	0.0264

Based on O-ring Chain (double pitch)



ROLLER CHAIN & DOUBLE PITCH CHAIN FOR CONVEYOR SYSTEM

Standard double pitch conveyor chain and double pitch conveyor chain with attachments, respectively with grease sealed by o-rings are available as a series for use in the following cases.

- Machine service condition is likely to cause elongation of chain
- Machine cannot be lubricated during the service life
- Machine is used in an environment with water or dust

Heat resistant o-rings and light friction type o-rings are also available. Please consult us.

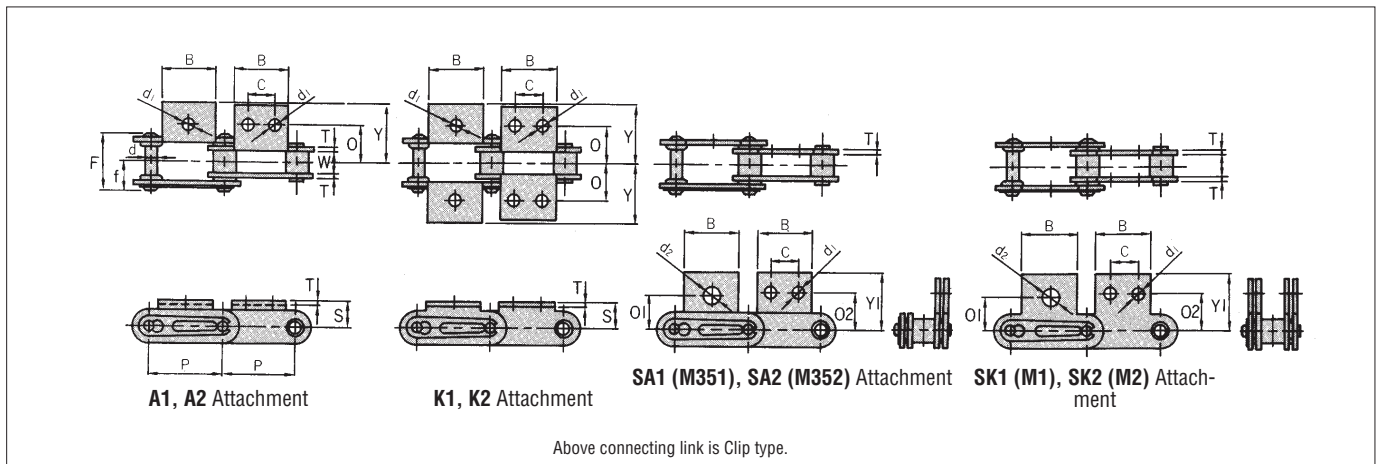

Chain No. DID	Pitch P	Roller Link Width W	Roller Dia. D	Pin			Plate		Avg. Tensile Strength lbs	Max. Allowable Load lbs	Approx. weight without attachment (lbs/FT)
				d	e	g	T	H			
RC2040LLDR	1.000	0.313	0.312	0.156	0.787	0.417	0.059	0.461	3630	594	0.349
RC2042LLDR			0.625								0.597
RC2050LLDR	1.250	0.375	0.400	0.200	0.941	0.500	0.079	0.594	6160	990	0.583
RC2052LLDR			0.750								0.905
RC2060HLLDR	1.500	0.500	0.469	0.235	1.319	0.705	0.126	0.677	8580	1452	0.979
RC2062HLLDR			0.875								1.462

Dimensions of Attachment

Chain No. DID	Attachment											Approx. additional weight per attachment (lbs)	
	s	o	Y	Y1	O1	O2	C	B	d1	d2	T	A, SA	K, SK
RC2040LLDR	0.359	0.500	0.811	0.780	0.437	0.531	0.375	0.752	0.138	0.205	0.059	0.0066	0.0132
RC2042LLDR													
RC2050LLDR	0.437	0.625	1.004	0.969	0.563	0.625	0.469	0.937	0.205	0.268	0.079	0.0132	0.0264
RC2052LLDR													
RC2060HLLDR	0.578	0.844	1.366	1.205	0.687	0.750	0.563	1.126	0.205	0.343	0.126	0.0352	0.0704
RC2062HLLDR													

3-4 Based on UR Chain (single pitch)



UR chain using sintered bushings can be expected to have a longer service life than Standard Roller Chain in lubrication-free operation. The amount of oil deposited in the sintered bushing is appropriate for contamination sensitive applications. They are interchangeable with Standard Roller Chain, and standard sprockets can be used.

Rustless type, delivering excellent corrosion resistance with nickel plated parts is also available (URN).

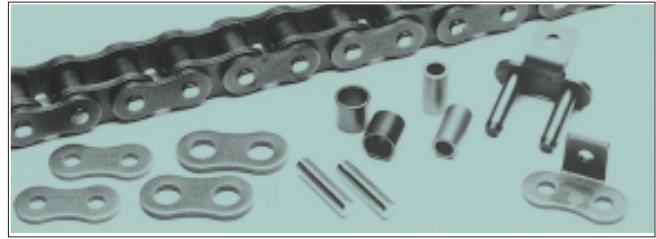

ROLLER CHAIN & DOUBLE PITCH CHAIN FOR CONVEYOR SYSTEM

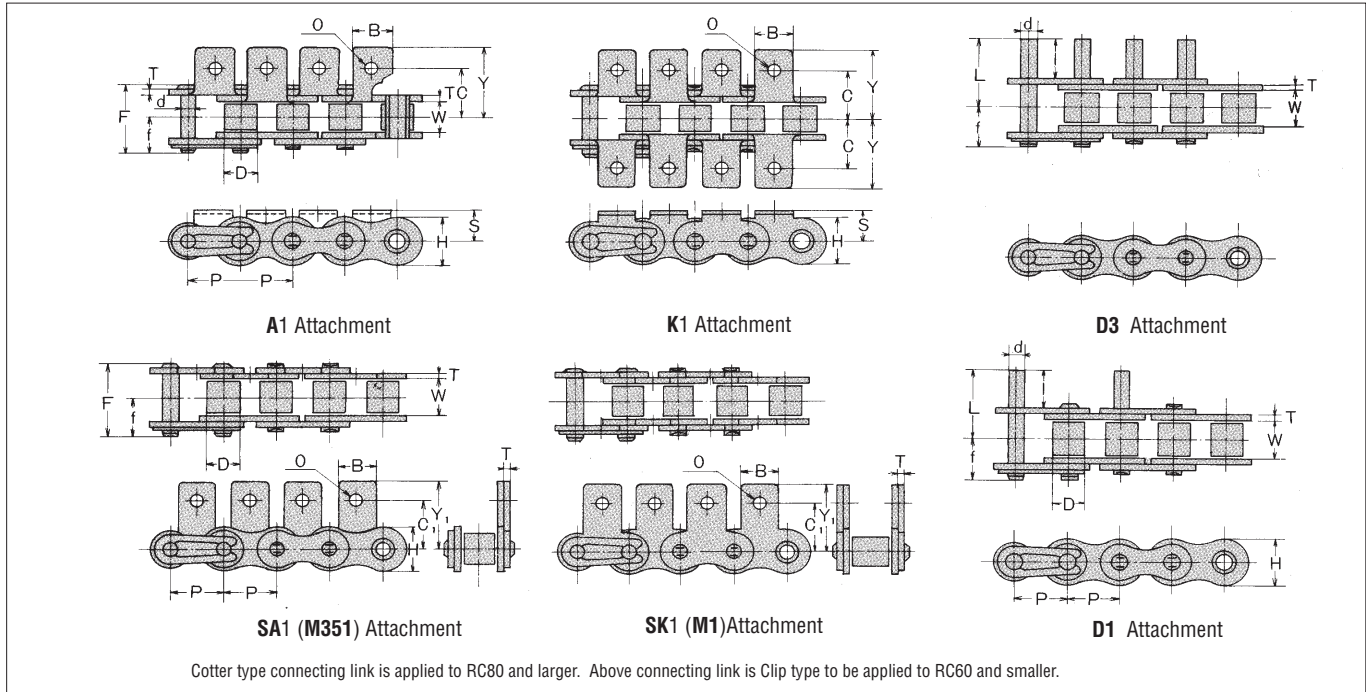

DID Chain No.		Pitch P	Roller Link Width W	Roller Dia. D	Pin			Plate		Avg. Tensile Strength lbs	Max. Allowable Load lbs	Approx. weight without attachment (lbs/FT)
Standard Type	Rustless Type				d	F	f	T	H			
RC40UR	RC40URN	0.500	0.313	0.312	0.156	0.693	0.374	0.059	0.472	3520	594	0.422
RC50UR	RC50URN	0.625	0.375	0.400	0.200	0.862	0.457	0.079	0.591	5720	968	0.711
RC60UR	RC60URN	0.750	0.500	0.469	0.235	1.067	0.563	0.094	0.713	8360	1408	0.966
RC80UR	RC80URN	1.000	0.625	0.625	0.313	1.394	0.748	0.126	0.945	14300	2398	1.790

Note: Chains marked C before the chain No. are for conveying system application.
 Thickness of inner link plate is equal to outer link plate.
 (Inner link plate of sintered bush chain for transmission is thicker than outer link plate.)

Dimensions of Attachment

DID Chain No.		Attachment										Approx. additional weight per attachment (lbs)		
Standard Type	Rustless Type	C	Y	S	C1	Y1	B	O	I	L	A, SA	K, SK	D1, D3	
RC40UR	RC40URN	0.500	0.693	0.312	0.500	0.689	0.375	0.138	0.375	0.661	0.0044	0.0088	0.0022	
RC50UR	RC50URN	0.625	0.906	0.406	0.625	0.890	0.500	0.205	0.469	0.827	0.0066	0.0132	0.0044	
RC60UR	RC60URN	0.750	1.063	0.469	0.719	1.031	0.625	0.205	0.562	1.012	0.0132	0.0264	0.0066	
RC80UR	RC80URN	1.000	1.374	0.625	0.969	1.341	0.750	0.268	0.750	1.335	0.0242	0.0484	0.0154	

Based on UR Chain (double pitch)

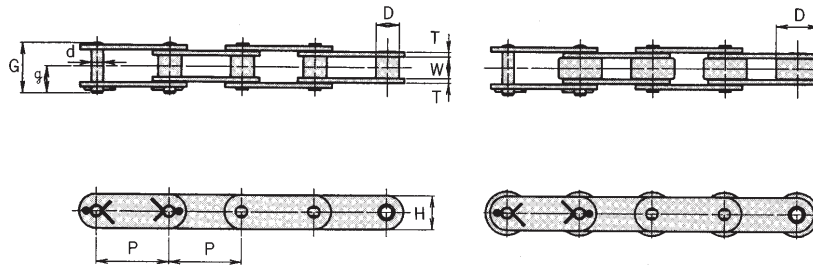

Clip type connecting link is applied to RC2060H and smaller. Above connecting link is Cotter type to be applied to RC2080H and larger.

Unit (inch)

DID Chain No.		Pitch P	Roller Link Width W	Roller Dia. D	Pin			Plate		Avg. Tensile Strength lbs	Max. Allowable Load lbs	Approx. weight without attachment (lbs/FT)
Standard Type	Rustless Type				f	G	g	T	H			
RC2040UR	RC2040URN	1.000	0.313	0.312	0.156	0.693	0.374	0.059	0.461	3520	594	0.329
RC2042UR	RC2042URN			0.625								0.577
RC2050UR	RC2050URN	1.250	0.375	0.400	0.200	0.862	0.457	0.079	0.594	5720	968	0.563
RC2052UR	RC2052URN			0.750								0.885
RC2060HUR	RC2060HURN	1.500	0.500	0.469	0.235	1.185	0.669	0.126	0.677	8360	1408	0.972
RC2062HUR	RC2062HURN			0.875								1.455
RC2080HUR	RC2080HURN	2.000	0.625	0.625	0.313	1.524	0.811	0.157	0.917	14300	2398	1.650
RC2082HUR	RC2082HURN			1.125								2.367

ROLLER CHAIN & DOUBLE PITCH CHAIN FOR CONVEYOR SYSTEM

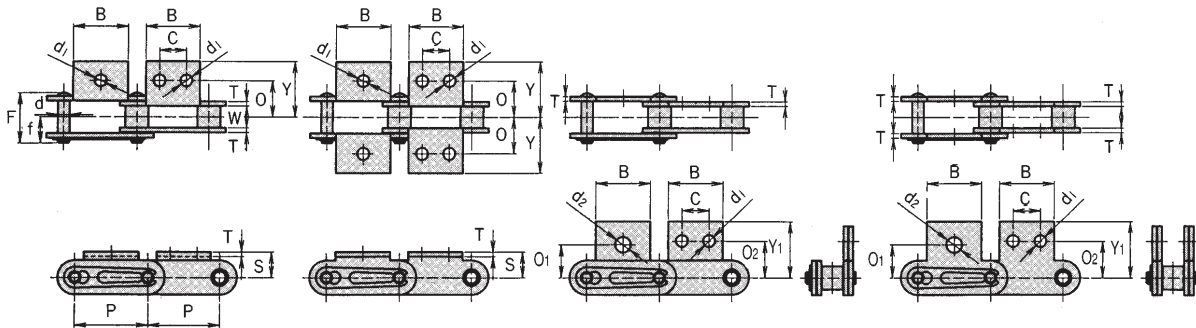

Cotter type connecting link is applied to RC2080H. Above connecting link is Clip type to be applied to RC2060H and smaller.

Dimensions of Attachment

Unit (inch)

DID Chain No.		Attachment											Approx. additional weight per attachment (lbs)	
Standard Type	Rustless Type	S	O	Y	Y1	O1	O2	C	B	d1	d2	T	A, SA	K, SK
RC2040UR	RC2040URN	0.359	0.500	0.764	0.780	0.437	0.531	0.375	0.752	0.138	0.205	0.059	0.0066	0.0132
RC2042UR	RC2042URN													
RC2050UR	RC2050URN	0.437	0.625	0.961	0.969	0.563	0.625	0.469	0.937	0.205	0.268	0.079	0.0132	0.0264
RC2052UR	RC2052URN													
RC2060HUR	RC2060HURN	0.578	0.844	1.311	1.205	0.687	0.750	0.563	1.126	0.205	0.343	0.126	0.0352	0.0704
RC2062HUR	RC2062HURN													
RC2080HUR	RC2080HURN	0.750	1.094	1.606	1.594	0.875	1.000	0.750	1.500	0.268	0.406	0.157	0.0748	0.1496
RC2082HUR	RC2082HURN													

3-5 Based on Stainless Steel Chain (single pitch)



Stainless steel chain is in our environment resistant chain series, and is suitable for machines and apparatus to be prevented from oils and rust in the industries of food, chemicals and so on.

Also, it has a very good heat resistance performance and can work well in the furnace and oven at high temperature.

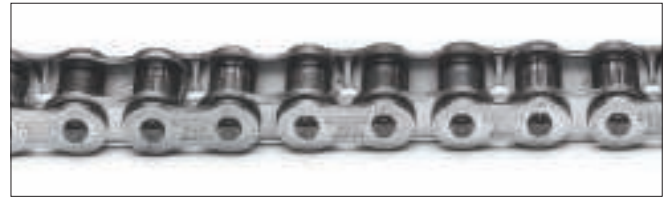

You can select from two different types of stainless steel, SSR and SR type.

SSR type use SS300 (18-8 stainless steel) in all components, and SR type uses precipitation hardened stainless steel in round parts.

Please select the proper stainless steel chain, based upon its maximum allowable load.

ROLLER CHAIN & DOUBLE PITCH CHAIN FOR CONVEYOR SYSTEM

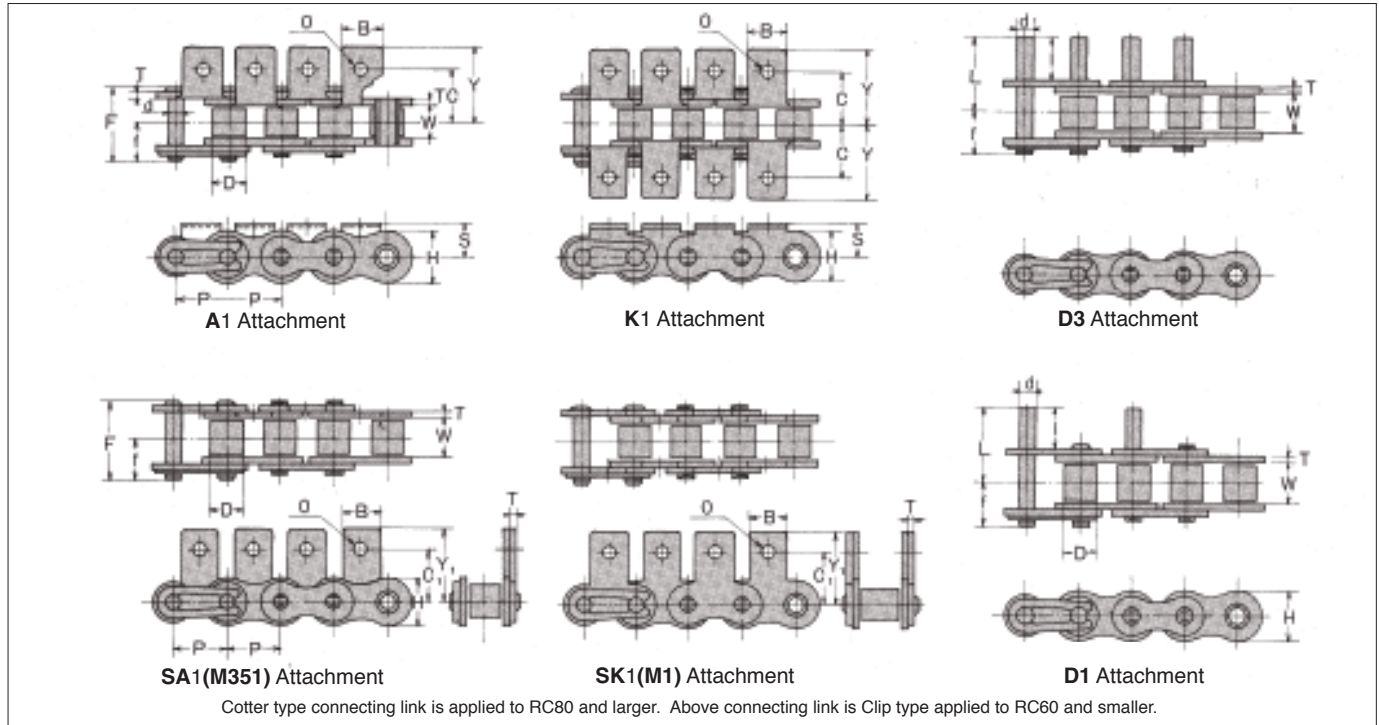

Chain No. DID	Pitch P	Roller Link Width W	Roller Dia. D	Pin						Plate			Max. Allowable Load (SS) lbs.	Max. Allowable Load (SSK) lbs.	Approx. weight without attachment (lbs/FT)
				d	E	F	G	f	g	T	H	h			
* RC25SSR	0.250	0.122	0.130	0.091	0.299	0.335	—	0.185	—	0.030	0.236	0.205	29	--	0.087
* RC35SSR, 35SR	0.375	0.184	0.200	0.141	0.465	0.508	—	0.276	—	0.050	0.354	0.307	59	88	0.228
RC40SSR, 40SR	0.500	0.309	0.313	0.156	0.642	0.689	—	0.368	—	0.059	0.472	0.409	99	154	0.429
RC50SSR, 50SR	0.625	0.370	0.400	0.200	0.807	0.850	—	0.447	—	0.079	0.591	0.512	154	231	0.711
RC60SSR, 60SR	0.750	0.495	0.469	0.234	1.018	1.063	—	0.555	—	0.094	0.713	0.614	231	352	1.046
RC80SSR, 80SR	1.000	0.620	0.625	0.312	1.280	—	1.366	—	0.726	0.126	0.949	0.819	396	594	1.757
RC100SSR, 100 SR	1.250	0.744	0.750	0.375	1.587	—	1.667	—	0.874	0.157	1.185	1.024	572	858	2.769

Note: Those marked with * indicate bush chain

Dimensions of Attachment

Chain No. DID	Pitch P	A1, K1 Attachment			SA1, SK1 Attachment		Common Dimensions		D1, D3 Attachment		Approx. additional weight per attachment (kg)				
		C	Y	S	C1	Y	B	O	I	L	A, SA	K, SK	D1, D3		
* RC25SSR	0.250	—	—	—	—	—	—	—	—	—	—	—	—	—	—
* RC35SSR, 35SR	0.375	0.374	0.563	0.252	0.374	0.579	0.311	0.110	0.375	0.575	0.002	0.004	0.002		
RC40SSR, 40SR	0.500	0.500	0.709	0.311	0.500	0.693	0.378	0.142	0.375	0.648	0.004	0.009	0.002		
RC50SSR, 50SR	0.625	0.626	0.902	0.406	0.626	0.890	0.504	0.205	0.469	0.825	0.007	0.013	0.004		
RC60SSR, 60SR	0.750	0.748	1.091	0.469	0.720	1.039	0.634	0.205	0.562	1.020	0.013	0.026	0.007		
RC80SSR, 80SR	1.000	1.000	1.386	0.626	0.969	1.343	0.748	0.268	0.750	1.335	0.024	0.048	0.015		
RC100SSR, 100 SR	1.250	1.252	1.748	0.780	1.248	1.709	1.000	0.343	0.938	1.638	0.053	0.106	0.026		

Note: Those marked with * indicate bush chain

Based on Stainless Steel Chain (double pitch)



ROLLER CHAIN & DOUBLE PITCH CHAIN FOR CONVEYOR SYSTEM

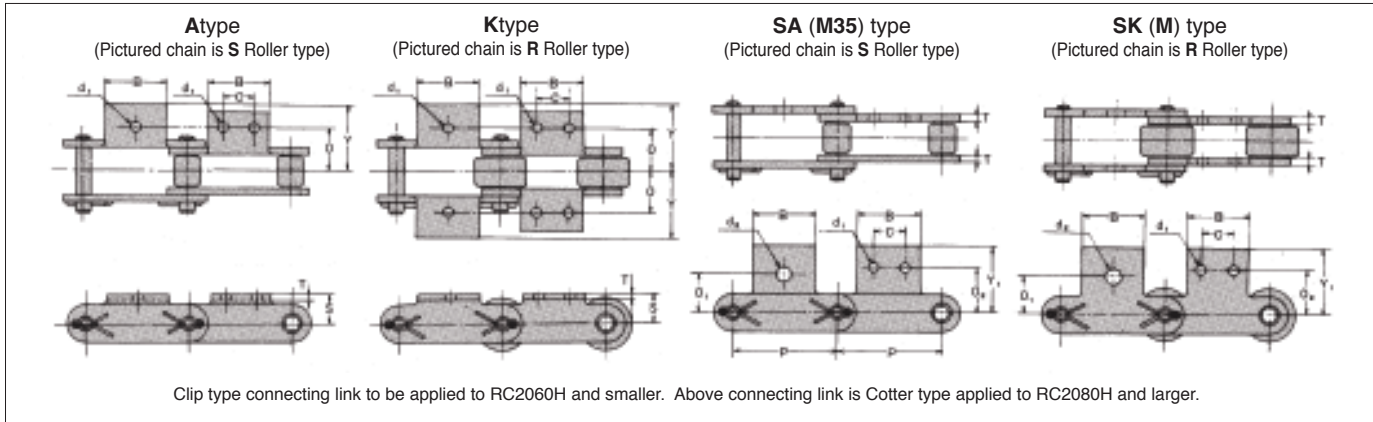

Unit (inch)

Chain No.		Pitch P	Roller Link Width W	Roller Dia. D	Pin			Plate		Avg. Tensile Strength lbs.	Max. Allowable Load lbs.	Approx. weight without attachment (lbs./FT)
DID					d	e	g	T	H			
RC2040SSR	RC2040SR	1.000	0.313	0.313	0.156	0.313	0.374	0.059	0.461	99	154	0.329
RC2042SSR	RC2042SR			0.625								0.563
RC2050SSR	RC2050SR	1.250	0.370	0.400	0.200	0.388	0.463	0.079	0.587	154	231	0.543
RC2052SSR	RC2052SR			0.750								0.858
RC2060HSSR	RC2060HSR	1.500	0.495	0.469	0.234	0.577	0.663	0.126	0.669	308	462	0.959
RC2062HSSR	RC2062HSR			0.875								1.435
RC2080HSSR	RC2080HSR	2.000	0.620	0.625	0.312	0.705	0.791	0.157	0.925	495	737	1.650
RC2082HSSR	RC2082HSR			1.125								2.354

Dimensions of Attachment

Unit (inch)

Chain No.		Pitch P	Attachment											Approx. additional weight per attachment (lbs)	
DID			S	O	Y	Y1	O1	O2	C	B	d1	d2	B	A, SA	K, SK
RC2040SSR	RC2040SR	1.000	0.358	0.500	0.748	0.780	0.437	0.531	0.375	0.760	0.142	0.205	0.059	0.0066	0.013
RC2042SSR	RC2042SR														
RC2050SSR	RC2050SR	1.250	0.437	0.625	0.949	0.969	0.563	0.626	0.469	0.945	0.205	0.268	0.079	0.0132	0.0264
RC2052SSR	RC2052SR														
RC2060HSSR	RC2060HSR	1.500	0.579	0.844	1.236	1.205	0.689	0.752	0.563	1.134	0.205	0.343	0.126	0.0374	0.0748
RC2062HSSR	RC2062HSR														
RC2080HSSR	RC2080HSR	2.000	0.752	1.094	1.642	1.630	0.874	1.000	0.750	1.500	0.268	0.406	0.157	0.0814	0.1628
RC2082HSSR	RC2082HSR														

- Note: 1. Attachments SA1, SK1, A1 and K1 are featured by only one hole given. Attachments SA2, SK2, A2, and K2 are featured by two holes given.
 2. Interval of attachments must be specified when you order.
 3. Without special instruction, attachments are given to outer link plates in case of even number of pitch between attachments.

4. DID Chain for Free Flow Conveyors

Many conveyors allowing the flow of conveyed articles to be blocked by inserting a stopper and flow freely by retracting the stopper are used in assembly lines of electric products and household appliances. DID chain for free flow conveyors are originally designed for free flow, and allow

conveyed articles to start flowing freely with a minimum of blocking resistance.

4-1 List of Chain for Free Flow Conveyors

DID chain for free flow conveyors can be classified into the following three major types.

Top roller chain

The chain has a third roller (top roller) above each link, and conveyed articles are placed on the rollers. It is an equal speed free flow Chain for a conveyor system in which the top rollers rotate idly when the conveyed articles are stopped.

Side roller chain

The pins of the chain are extended, and third rollers (outboard rollers) are installed with the pins as shafts. If the side rollers run on a floor, the chain becomes a double speed free flow chain for conveyor system, and if the chain rollers run on a rail, the chain becomes an equal speed free flow chain for conveyor system. Chain is available for single pitch and double pitch, and chain with a brake is also available. The chain is listed below.

DID Top Roller and Side Roller Chain

	Top Roller Chain						Side Roller Chain			Hollow Pin Chain (HP)	Flexible Chain (FX)	Straight Link Plate Roller Chain (F)
	Single Strand				Double Strand		with Guide Plate (SG)	with Brake				
	every 2 pitches (2P-TR)	every single pitches (2P-TR)	with Guide Plate (TG)	with Brake	every 2 pitches (2P-TR) Inner	with Guide Plate (1P-TR)						
RC35	—	—	—	—	— *2	—	—	—	—	—	0	
RC40	inner	Ⓢ *3	inner/outer	0	outer/inner	—	0 *1	—	0 *1	0	0	
RC50	inner	Ⓢ	inner/outer	—	outer/inner	—	0	—	—	0	0	
RC60	inner	Ⓢ	inner/outer	—	outer/inner	—	0	—	—	0	0	
RC80	inner	Ⓢ	inner/outer	—	outer/inner	—	—	—	—	—	0	
RC100	inner	Ⓢ	inner/outer	—	outer/inner	—	—	—	—	—	0	
RC120	—	—	—	—	—	—	—	—	—	—	0	
RC2040	outer/inner	0	inner	—	outer/inner	0	0	—	—	0	—	
RC2050	outer/inner	0	inner	—	outer/inner	0	0	—	—	0	—	
RC2060H	outer/inner	0	inner	—	outer/inner	0	0	—	—	0	—	
RC2080H	outer/inner	0	inner	—	outer/inner	0	0	—	—	0	—	
RC2100H	outer/inner	0	inner	—	outer/inner	0	0	—	—	—	—	
RC2042	outer/inner	0	inner	—	outer/inner	0	—	Ⓞ *3	—	0	—	
RC2052	outer/inner	0	inner	—	outer/inner	0	—	Ⓞ	—	0	—	
RC2062H	outer/inner	0	inner	—	outer/inner	0	—	Ⓞ	—	0	—	
RC2082H	outer/inner	0	inner	—	outer/inner	0	—	Ⓞ	—	0	—	
RC2102H	outer/inner	0	inner	—	outer/inner	0	—	Ⓞ	—	—	—	

Note: *1. Marked 0 are lined up as standard.

*2. Inner and outer specifies the link plate on which attachment is fixed.

For the chain marked inner/outer, top roller to be affixed on inner link plates when no instruction is given.

For the chain marked outer/inner, top roller to be affixed on outer link plated when no instruction is given.

*3. Diameter of top roller of those marked Ⓢ is smaller than normal in the same size.

Diameter of top roller of those marked Ⓞ is larger than normal in the same size.

4-2 Top Roller Chain

With conveyed articles directly placed on top rollers, the chain is continuously driven, and a stopper provided on the conveyor keeps the conveyed articles stored or temporarily stopped.

ROLLER CHAIN & DOUBLE PITCH CHAIN FOR CONVEYOR SYSTEM

4-2-1 Single pitch Top roller chain

• Every-Link Top Roller Chain

[Example of Description: RC50TR-DU1]

RC 50-TR DU-1

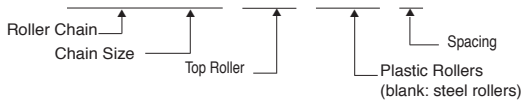

(The diameter of top rollers is smaller than that of every-other-link top roller)

• Every-Other-Link Top Roller Chain

[Example of Description: RC50TR2]

RC 50-TR 2

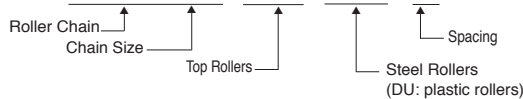

(Inner link top rollers are the standard for every-other-pitch top roller chain)

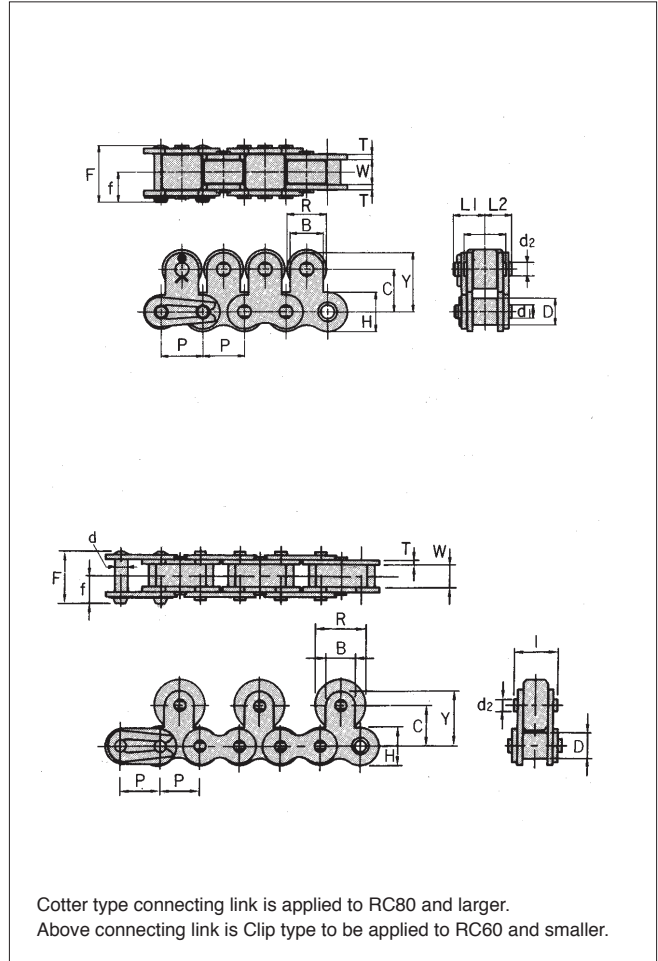

Dimensions of Chain Portion

Unit (inch)

Chain No. DID	Pitch P	Roller Link Width W	Roller Dia. D	Pin			Plate		Avg. Tensile Strength lbs.	Max. Allowable Load lbs.
				d	F	f	T	H		
RC40-TR	0.500	0.313	0.312	0.156	0.693	0.374	0.059	0.472	4180	594
RC50-TR	0.625	0.375	0.400	0.200	0.862	0.457	0.079	0.591	6380	990
RC60-TR	0.750	0.500	0.469	0.235	1.059	0.563	0.094	0.713	9900	1430
RC80-TR	1.000	0.625	0.625	0.313	1.394	0.748	0.126	0.945	17600	2420
RC100-TR	1.250	0.750	0.750	0.376	1.673	0.898	0.157	1.177	26620	3850

Dimensions of Top Roller Portion

Unit (inch)

Chain No. DID	Every 2 Pitch Top Roller								Every 1 Pitch Top Roller									
	R	C	Y	B	d2	I	Approx. Weight (lbs./FT)		R	C	Y	B	d2	L1	L2	L3	Approx. Weight (lbs./FT)	
							Steel Top Roller	Plastic Top Roller									Steel Top Roller	Plastic Top Roller
RC40-2P-TR	0.625	0.500	0.687	0.374	0.156	0.520	0.811	0.570	0.433	0.500	0.687	0.374	0.156	0.398	0.327	0.520	1.274	0.697
RC50-2P-TR	0.750	0.638	0.888	0.500	0.206	0.638	1.247	0.945	0.591	0.638	0.888	0.500	0.206	0.472	0.402	0.638	1.670	1.187
RC60-2P-TR	0.875	0.720	1.033	0.626	0.235	0.803	1.891	1.388	0.709	0.720	1.033	0.626	0.235	0.594	0.500	0.803	2.555	1.743
RC80-2P-TR	1.125	0.969	1.344	0.752	0.313	1.012	3.212	2.427	0.945	0.969	1.344	0.752	0.313	0.748	0.646	1.012	4.439	3.138
RC100-2P-TR	1.563	1.252	1.752	1.000	0.376	1.220	5.116	3.641	1.181	1.252	1.752	1.000	0.376	0.898	0.795	1.220	6.545	4.573

Note: 1. Approx. weight is of the chain with every 2 pitch Top Roller.
2. The material of plastic top roller is polyacetal.

• Double Strand Every-Other-Link Top Roller Chain

[Example of Description:
RC40-2TRDU2 (Top Roller
Outer Link)]

RC 40-2-TR outer DU 2

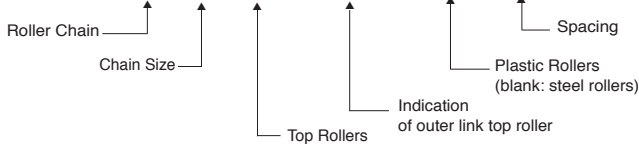

1. Standard inner link top roller type uses two separate rollers as illustrated. However, one-piece roller is also available.
2. A chain with top rollers attached to all the links is available. In this type, the dimension R is different. See every-link top roller chain section.
3. The connecting link for RC80-2 ~ RC100-2 are cotter type. Dimensions of pins are as shown in the table below.

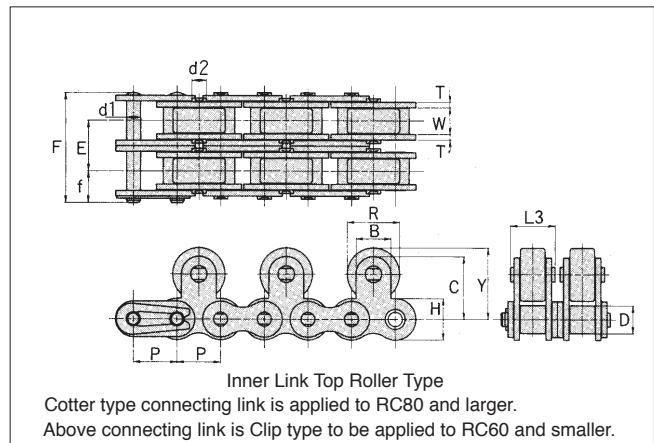
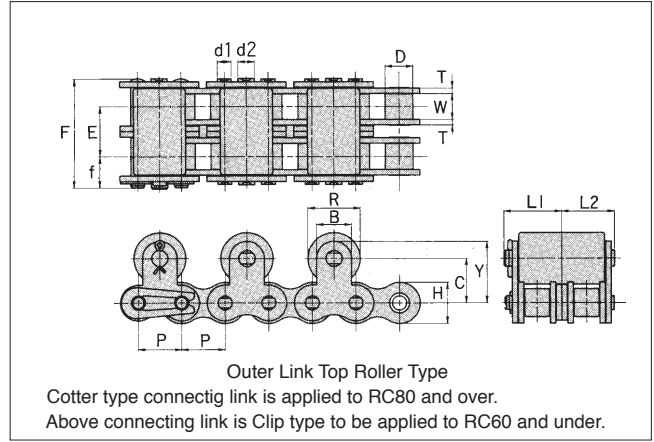

Dimensions of Chain Portion

Unit (inch)

Chain No. DID	Pitch P	Roller Link Width W	Roller Dia. D	Transverse Pitch E	Pin			Plate		
					d	F	f	T	H	h
RC40-2-2PTR-F	0.500	0.313	0.312	0.567	0.156	1.264	0.374	0.059	0.472	0.409
RC50-2-2PTR-F	0.625	0.375	0.400	0.713	0.200	1.579	0.457	0.079	0.591	0.512
RC60-2-2PTR-F	0.750	0.500	0.469	0.898	0.235	1.961	0.563	0.094	0.713	0.614
RC80-2-2PTR-F	1.000	0.625	0.625	1.154	0.313	2.547	0.748	0.126	0.945	0.819
RC100-2-2PTR-F	1.250	0.750	0.750	1.409	0.376	3.098	0.898	0.157	1.177	1.024

Dimensions of Top Roller Portion

Unit (inch)

Chain No. DID	R	C	Y	B	d2	L1	L2	L3
RC40-2-2PTR-F	0.625	0.500	0.687	0.374	0.156	0.673	0.610	0.520
RC50-2-2PTR-F	0.750	0.638	0.888	0.500	0.206	0.827	0.760	0.638
RC60-2-2PTR-F	0.875	0.720	1.033	0.626	0.235	1.047	0.953	0.803
RC80-2-2PTR-F	1.125	0.969	1.344	0.752	0.313	1.323	1.224	1.012
RC100-2-2PTR-F	1.563	1.252	1.752	1.000	0.376	1.598	1.500	1.220

4-2-2 Double Pitch Top Roller Chain

• Simplex Every-Link Top Roller Chain [Example of Description]

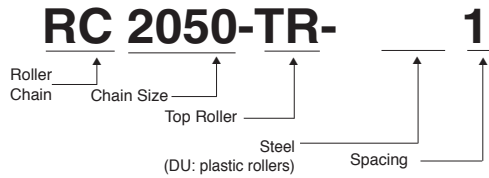

• Duplex Every-Link Top Roller Chain [Example of Type Indication]

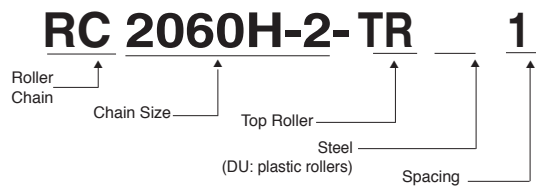

1. The connecting links for RC2080H-2 ~ RC2100H-2 are cotter types. The dimensions of pins are as shown in the table below.
2. For RC2060H-2 or larger, dimension E, transverse pitch, is different from that of the corresponding DID standard sprocket.
3. When a top roller is required for every even-numbered link, the top rollers will be attached to inner links unless otherwise specified.

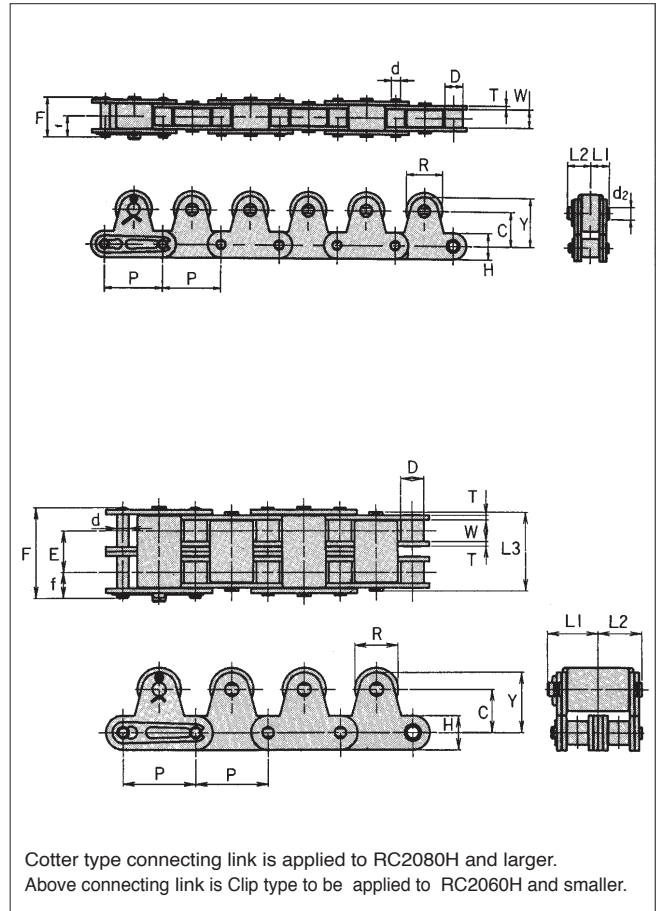

ROLLER CHAIN & DOUBLE PITCH CHAIN FOR CONVEYOR SYSTEM

Dimensions of Chain Portion

Unit (inch)

Chain No. DID	Pitch P	Roller Link Width W	Roller Dia. D	Pin			Plate		Transverse Pitch, Double E	Strength, Single Strand		Strength, Single Strand	
				d	e	g	T	H		Avg. Tensile Strength lbs.	Max. Allowable Load lbs.	Avg. Tensile Strength lbs.	Max. Allowable Load lbs.
RC2040-TR RC2042-TR	1.000	0.313	0.312 0.625	0.156	0.693	0.374	0.059	0.461	0.567	3828	594	7656	1012
RC2050-TR RC2052-TR	1.250	0.375	0.400 0.750	0.200	0.862	0.457	0.079	0.594	0.713	6446	990	12892	1672
RC2060H-TR RC2062H-TR	1.500	0.500	0.469 0.875	0.235	1.232	0.669	0.126	0.677	1.031	9020	1452	18040	2464
RC2080H-TR RC2082H-TR	2.000	0.625	0.625 1.125	0.313	1.524	0.815	0.157	0.917	1.283	15400	2530	30800	4290
RC2100H-TR RC2102H-TR	2.500	0.750	0.750 1.563	0.376	1.823	0.965	0.189	1.134	1.539	25300	4180	50600	7106

Dimensions of Top Roller Portion

Unit (inch)

Chain No. DID	Every 2 Pitch Top Roller									Every 2 Pitch Top Roller								
	Dimensions						Approx. Weight (lbs/FT)			Dimensions						Approx. Weight (lbs/FT)		
	R	C	Y	B	d2	I	Steel Top Roller	Plastic Top Roller		R	C	Y	B	d2	L1	L2	Steel Top Roller	Plastic Top Roller
RC2040-TR RC2042-TR	0.625	0.591	0.827	0.333	0.398	0.206	0.878 1.127	0.597 0.845		0.625	0.591	0.827	0.206	0.673	0.610	1.091	1.663 2.092	1.100 1.569
RC2050-TR RC2052-TR	0.750	0.748	1.043	0.413	0.508	0.235	1.368 1.690	0.966 1.287		0.750	0.748	1.043	0.235	0.866	0.772	1.354	2.595 3.205	1.831 2.441
RC2060H-TR RC2062H-TR	0.875	0.906	1.244	0.581	0.699	0.313	2.427 2.910	1.817 2.307		0.875	0.906	1.244	0.313	1.201	1.098	1.929	4.607 5.525	3.447 4.379
RC2080H-TR RC2082H-TR	1.125	1.142	1.594	0.715	0.837	0.376	3.742 4.486	2.830 3.574		1.125	1.142	1.594	0.376	1.472	1.358	2.382	7.108 8.523	5.371 6.786
RC2100H-TR RC2102H-TR	1.563	1.394	1.957	0.870	1.071	0.563	6.048 7.564	4.305 5.820		1.563	1.394	1.957	0.563	1.819	1.642	2.874	11.487 14.370	8.174 11.058

4-2-3 Overturn Prevention Type Chain

Chain with overturn prevention links installed to prevent overturning of conveyed articles is also available.

[Example of Description]

RC 50 TR 2 (TG 6 inner)

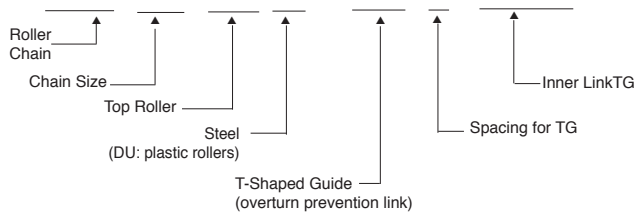

1. A single pitch every-link top roller chain with overturn prevention links is not available. SK1 (M1) attachments can be used as TG for overturn prevention.
2. Overturn prevention links for double pitch chain are inner link TG.

Guide Link on Inner Link Plate for Single Pitch Chain

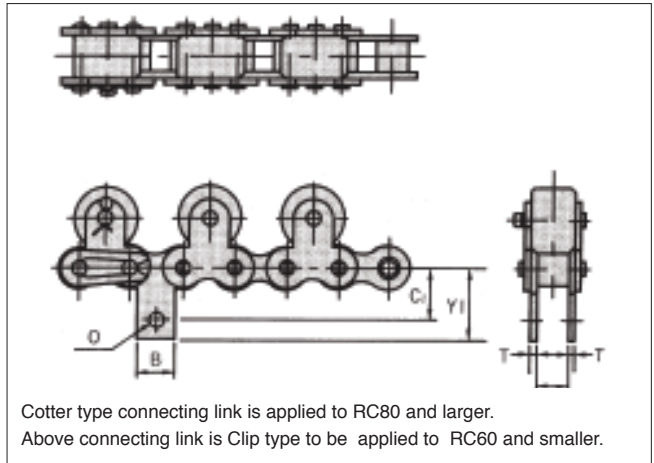

Guide Link for Double Pitch Chain

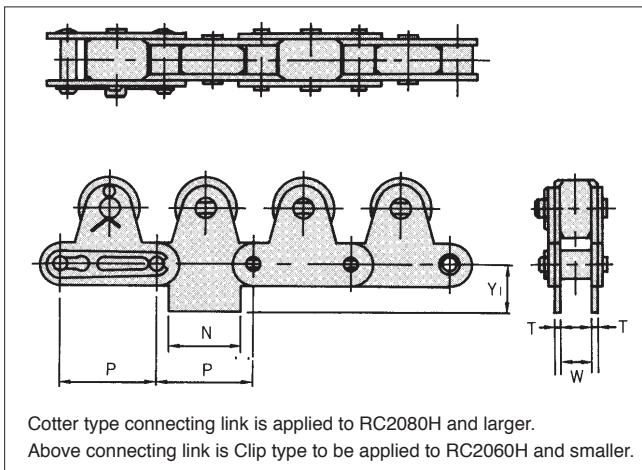

Guide Link on Outer Link Plate for Single Pitch Chain

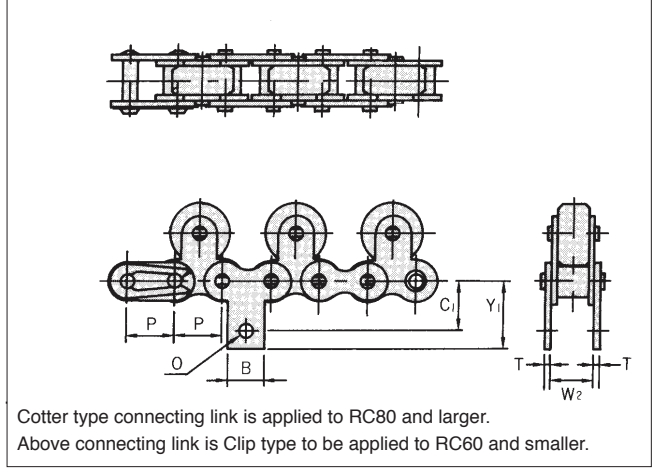

Double Pitch TG Link

Unit (inch)

Chain No. DID	Pitch P	Dimensions			
		N	Y1	T	W
RC2040-TG	1.000	0.752	0.500	0.059	0.313
RC2050-TG	1.250	0.937	0.626	0.079	0.375
RC2060H-TG	1.500	1.126	0.752	0.126	0.500
RC2080H-TG	2.000	1.500	1.000	0.157	0.625
RC2100H-TG	2.500	1.874	1.252	0.189	0.750

Single Pitch TG Link

Unit (inch)

Chain No. DID	Pitch P	Dimensions						
		B	Y1	C1	T	W1	W2	O
RC40-TG	0.500	0.374	0.689	0.500	0.059	0.313	0.442	0.138
RC50-TG	0.625	0.500	0.890	0.625	0.079	0.375	0.547	0.205
RC60-TG	0.750	0.626	1.031	0.719	0.094	0.500	0.701	0.205
RC80-TG	1.000	0.752	1.341	0.969	0.126	0.625	0.892	0.268
RC100-TG	1.250	1.000	1.683	1.250	0.157	0.750	1.083	0.343

4-3 Side Roller Chain

4-3-1 Single pitch side roller chain

A side roller chain receives the loads of conveyed articles by side rollers, and is used for a free flow conveyor running on a rail. Since the number of rollers for receiving the loads of conveyed articles is large, a side roller chain can convey heavier articles than a top roller chain made of the same material. Furthermore, since the center of gravity of the chain is low, stability is also good. All the connecting links of side roller chain are cotter types as illustrated.

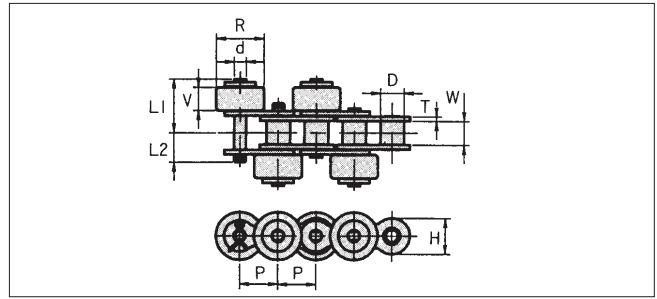

Unit (inch)

Chain No. DID	Pitch P	Roller Link Width W	Roller Dia. D	Plate		Pin				Side Roller		Avg. Tensile Strength lbs.	Max. Allowable Load lbs.	Approx. Weight (lbs/FT)	
				T	H	d	L1	L2	L3	R	V			Steel Side Roller	Plastic Side Roller
RC40-SR	0.500	0.313	0.312	0.059	0.472	0.156	0.697	0.398	0.768	0.625	0.307	3740	594	1.113	0.624
RC50-SR	0.625	0.375	0.400	0.079	0.591	0.200	0.854	0.472	0.925	0.750	0.370	6270	990	1.636	0.966
RC60-SR	0.750	0.500	0.469	0.094	0.713	0.235	1.094	0.594	1.260	0.875	0.496	9020	1430	2.401	1.381
RC80-SR	1.000	0.625	0.625	0.126	0.945	0.313	1.382	0.815	1.484	1.125	0.622	17600	2420	3.976	2.401
RC100-SR	1.250	0.750	0.750	0.157	1.177	0.376	1.748	0.898	1.850	1.563	0.748	26620	3850	6.706	3.728

Note: 1. L3 indicates the value of L1 when cotter type pin is applied.
2. The material of plastic side roller is polyacetal.

4-3-2 Double pitch side roller chain

S roller chain

[Example of type expression]

RC 2050-SR-2 DU T

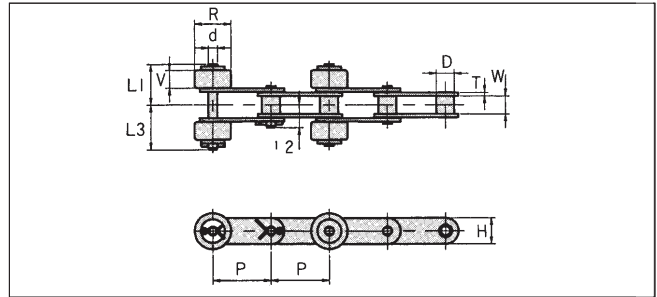
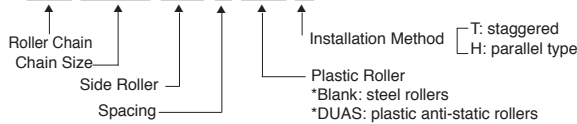

Chain No. DID	Pitch P	Roller Link Width W	Roller Dia. D	Plate		Pin				Side Roller		Avg. Tensile Strength lbs.	Max. Allowable Load lbs.	Approx. Weight (lbs/FT)	
				T	H	d	L1	L2	L3	R	V			Steel Side Roller	Plastic Side Roller
RC2040-SR	1.000	0.313	0.312	0.059	0.461	0.156	0.697	0.398	0.768	0.625	0.307	3828	594	0.671	0.429
RC2050-SR	1.250	0.375	0.400	0.079	0.594	0.200	0.854	0.472	0.925	0.750	0.370	6446	990	1.026	0.691
RC2060H-SR	1.500	0.500	0.469	0.126	0.677	0.235	1.157	0.669	1.260	0.875	0.496	9020	1452	1.750	1.167
RC2080H-SR	2.000	0.625	0.625	0.157	0.917	0.313	1.445	0.815	1.563	1.125	0.622	15400	2530	2.890	2.132
RC2100H-SR	2.500	0.750	0.750	0.189	1.134	0.376	1.740	0.965	1.862	1.563	0.748	25300	4180	4.734	3.239

Note: The material of plastic side roller is polyacetal.

4-3-3 Meandering prevention type chain

An R roller type double pitch chain with side rollers has a construction in which higher inner plates are used to keep the rail between them, prevent derailing of the R rollers. Furthermore, side rollers are also larger, enabling them to withstand a higher live load.

[Example of type expression]

RC 2052-SG-2 DU T

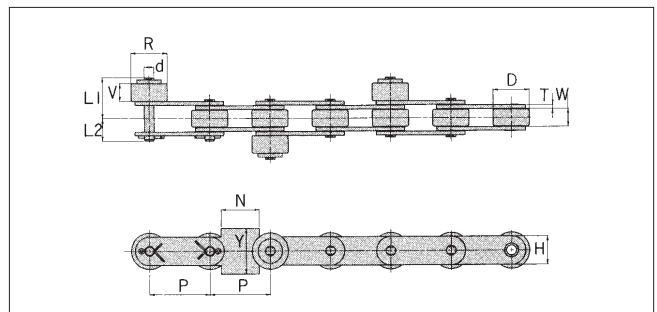
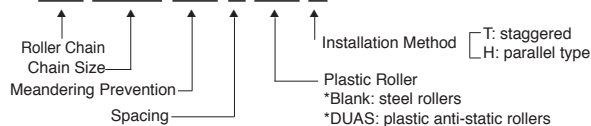

Chain No. DID	Pitch P	Roller Link Width W	Roller Dia. D	Plate		Pin				Side Roller		N	Y	Approx. Weight (lbs/FT)	
				H	d	d	L1	L2	R	V	Steel Side Roller			Plastic Side Roller	
RC2042-SG	1.000	0.313	0.625	0.059	0.461	0.156	0.697	0.398	0.906	0.512	0.650	0.748	1.140	0.697	
RC2052-SG	1.250	0.375	0.750	0.079	0.594	0.200	0.854	0.472	1.063	0.512	0.787	0.945	1.502	1.019	
RC2062H-SG	1.500	0.500	0.875	0.126	0.677	0.235	1.157	0.669	1.181	0.512	1.000	1.063	2.106	1.603	

Note: The material of plastic side roller is polyacetal.

ROLLER CHAIN & DOUBLE PITCH CHAIN FOR CONVEYOR SYSTEM

4-4 Free Flow Chain with Brake

If the coefficient of rotating friction of carrier rollers is too small, an unintended slight resistance causes conveyed articles to be retained.

To prevent unstable retention, several brakes of carrier rollers are installed to increase the coefficient of rotating friction in a free flow chain with brakes.

4-4-1 Top roller chain with brake

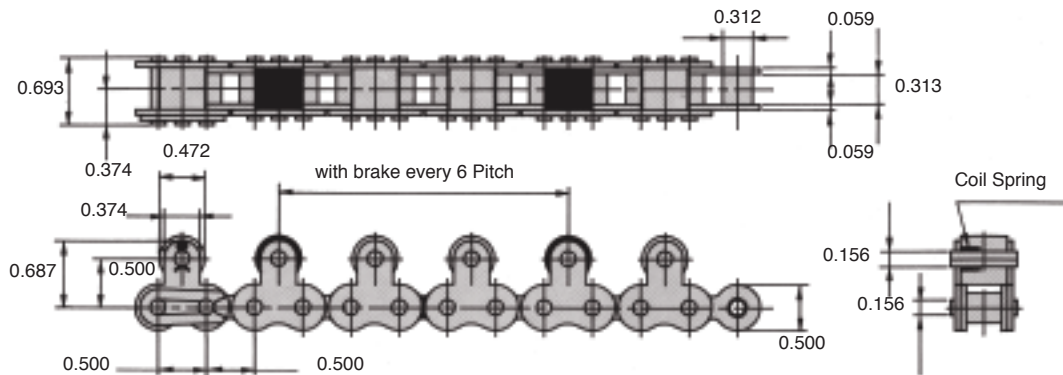

4-4-2 Side roller chain with brake

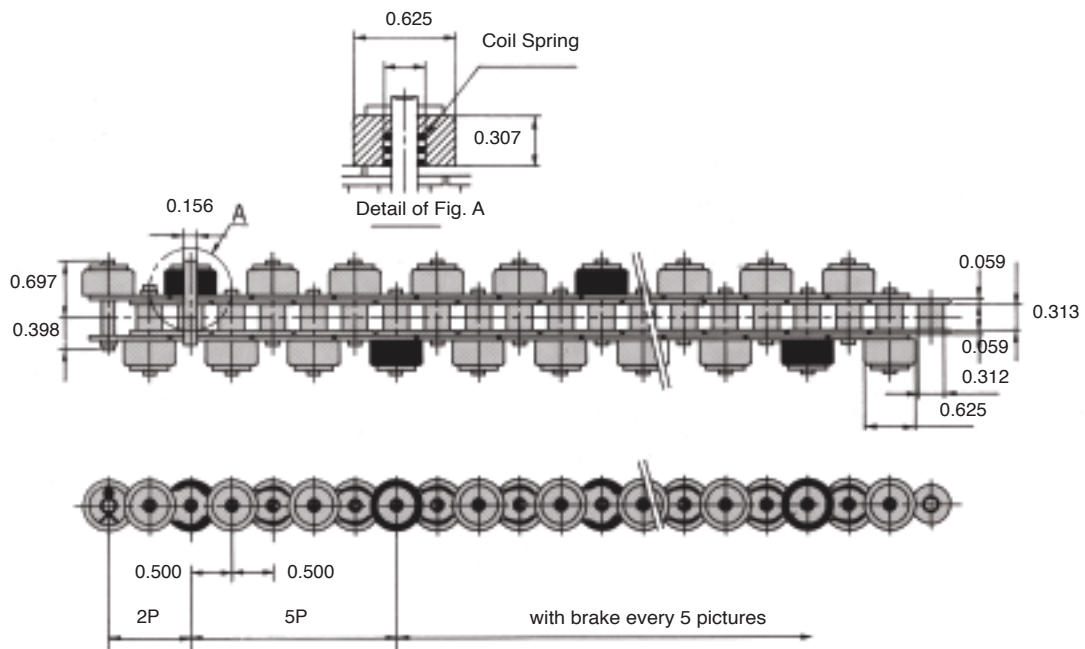

The above illustrations show cases where brakes are installed for top rollers and side rollers of RC40. Top rollers and side rollers can be arranged as requested.

5. Other Chains for Conveyor Systems

5-1 Hollow pin chain

This chain is connected by hollow pins, and the hollow holes can be used to install various attachments. In a hollow pin chain, the hollow pins are the same as the bushings of the corresponding standard chain in diameter, and it can be said that a hollow pin chain is a bushing chain in which pins with the same diameter as that of the rollers of the corresponding standard chain are used as bushings.

Standard sprockets can be used. The connecting links are special snap ring types for hollow pin chain as illustrated below. Since no offset link is available, determine the length of a chain by an even number of links.

• Single Pitch Chain

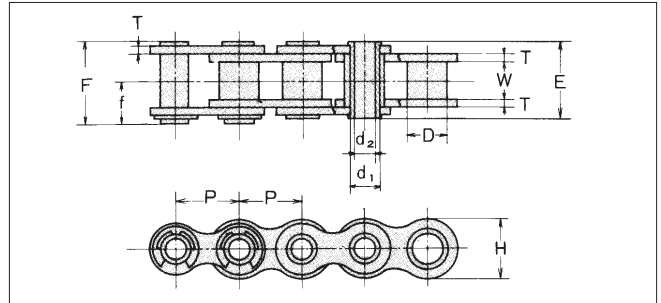
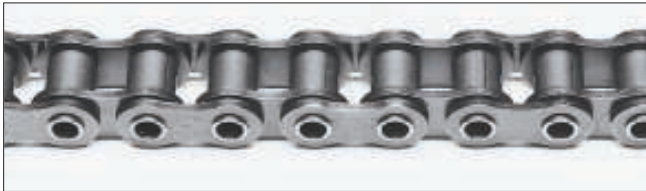

Unit (inch)

Chain No. DID	Pitch P	Roller Link Width W	Roller Dia. D	Pin					Plate		Avg. Tensile lbs	Max. Allowable lbs	Approx. Weight (lbs/FT)
				d1	d2	E	F	f	T	H			
RC40HP	0.500	0.313	0.312	0.221	0.157	0.630	0.689	0.374	0.059	0.472	2420	396	0.349
RC50HP	0.625	0.375	0.400	0.283	0.202	0.795	0.854	0.457	0.079	0.591	4400	704	0.577
RC60HP	0.750	0.500	0.469	0.333	0.236	0.988	1.055	0.563	0.094	0.713	5940	968	0.805

• Double Pitch Chain

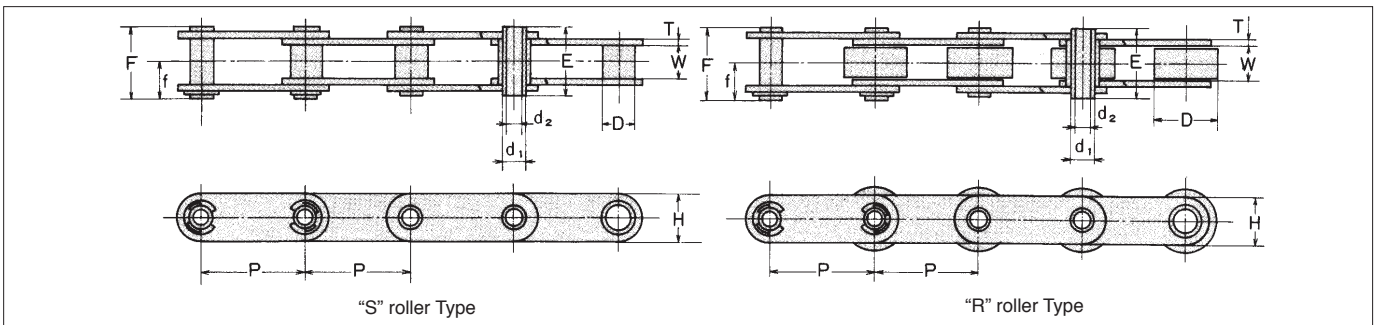

Unit (inch)

Chain No. DID	Pitch P	Roller Link Width W	Roller Dia. D	Pin					Plate		Avg. Tensile lbs	Max. Allowable lbs	Approx. Weight (lbs/FT)
				d1	d2	E	F	f	T	H			
RC2040HP	1.000	0.313	0.312	0.221	0.157	0.630	0.689	0.374	0.059	0.461	2420	396	0.295
RC2042HP			0.625										0.543
RC2050HP	1.250	0.375	0.400	0.283	0.202	0.795	0.854	0.457	0.079	0.594	4400	704	0.503
RC2052HP			0.750										0.811
RC2060HP	1.500	0.500	0.469	0.333	0.236	0.988	1.055	0.563	0.094	0.677	5940	946	0.885
RC2062HP			0.875										1.871
RC2080HP	2.000	0.625	0.625	0.445	0.316	1.280	1.343	0.701	0.126	0.917	10780	1716	1.153
RC2082HP			1.125										1.790

ROLLER CHAIN & DOUBLE PITCH CHAIN FOR CONVEYOR SYSTEM

5-2 Flexible Chain

A DID flexible chain is a roller chain which can be greatly bent in the transverse direction, and is suitable for curved traveling. For the chain, sprockets for JIS/ANSI Standard Roller Chain can be used. This chain with attachments can also be used as a conveyor for curved applications.

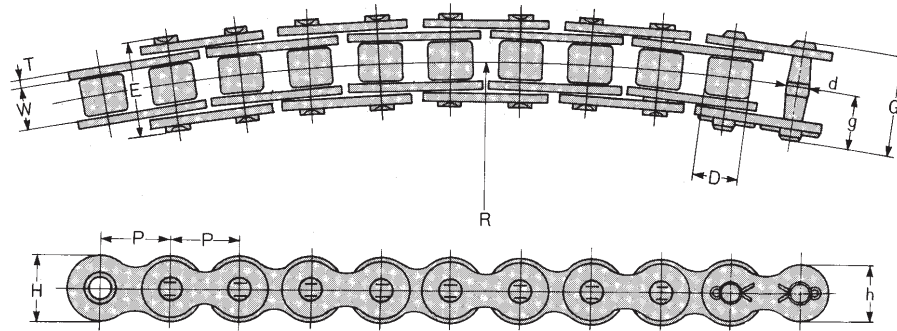

Connecting link is Cotter type only.

Unit (inch)

Chain No.	Pitch P	Roller Link Width W	Roller Dia. D	Pin					Plate		Min. lateral bending radius R	Avg. Tensile Strength lbs	Max. Allowable Load lbs	Approx. Weight (lbs/FT)
				d1	d2	E	F	f	T	H				
RC40FX	0.500	0.313	0.312	0.156	0.665	0.732	0.409	0.059	0.472	0.409	13.780	3520	418	0.402
RC50FX	0.625	0.375	0.400	0.200	0.815	0.886	0.484	0.079	0.591	0.512	15.748	5500	638	0.691
RC60FX	0.750	0.500	0.469	0.235	1.016	1.118	0.606	0.094	0.713	0.614	19.685	7920	902	0.878
RC80FX	1.625	0.500	0.625	0.313	1.331	1.437	0.768	0.126	0.945	0.819	23.622	13860	1562	1.743

Note: Lateral bending radius should be designed being larger than above R in bending operation.

5-3 Flat Plate (Straight Sidebar) Type Roller Chain

Since the plates are flat, chain guides, etc. are less susceptible to damage, and a roller chain can also be used for a conveyor system. (Outer plates are the same as inner plates in form.)

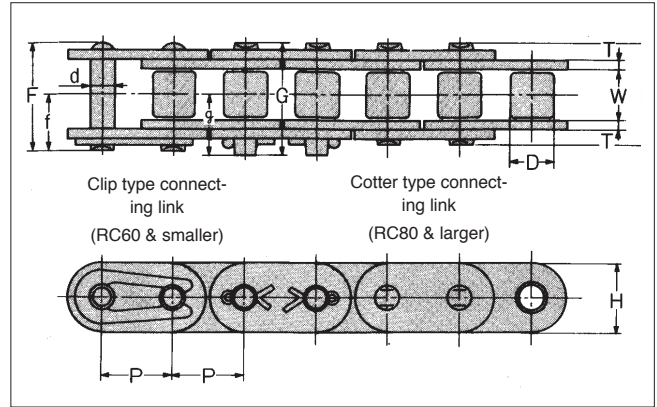
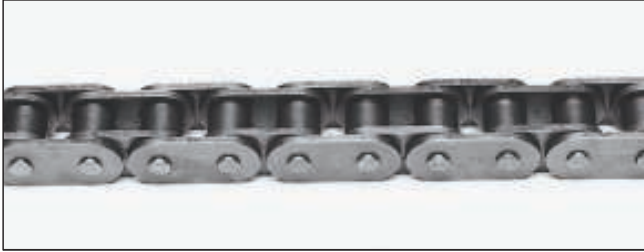

ROLLER CHAIN & DOUBLE PITCH CHAIN FOR CONVEYOR SYSTEM

Unit (inch)

Chain No. DID	Pitch P	Roller Link Width W	Roller Dia. D	Pin				Plate		Avg. Tensile Strength lbs	Approx. Weight (lbs/FT)
				d	E	G	g	T	H		
* RC35FR	0.375	0.188	0.200	0.141	0.472	0.516	0.287	0.049	0.354	2530	0.262
RC40FR	0.500	0.313	0.312	0.156	0.650	0.693	0.374	0.059	0.472	4290	0.436
RC50FR	0.625	0.375	0.400	0.200	0.799	0.862	0.457	0.079	0.591	6930	0.771
RC60FR	0.750	0.500	0.469	0.235	1.000	1.059	0.563	0.094	0.713	9900	1.140
DID Chain No.	P	W	D	d	E	G	g	T	H	lbs	(lbs/FT)
RC80FR	1.000	0.625	0.625	0.313	1.283	1.394	0.748	0.126	0.945	17600	1.790
RC100FR	1.250	0.750	0.750	0.376	1.555	1.673	0.894	0.157	1.177	26620	2.810
RC120FR	1.500	1.000	0.875	0.437	1.957	2.087	1.110	0.189	1.413	37400	4.104

Note: Please consult with us if desired size is not available in above table.

Note: Those marked with * indicate Bush Chain

Example: Application of Flat Link Plate Roller Chain

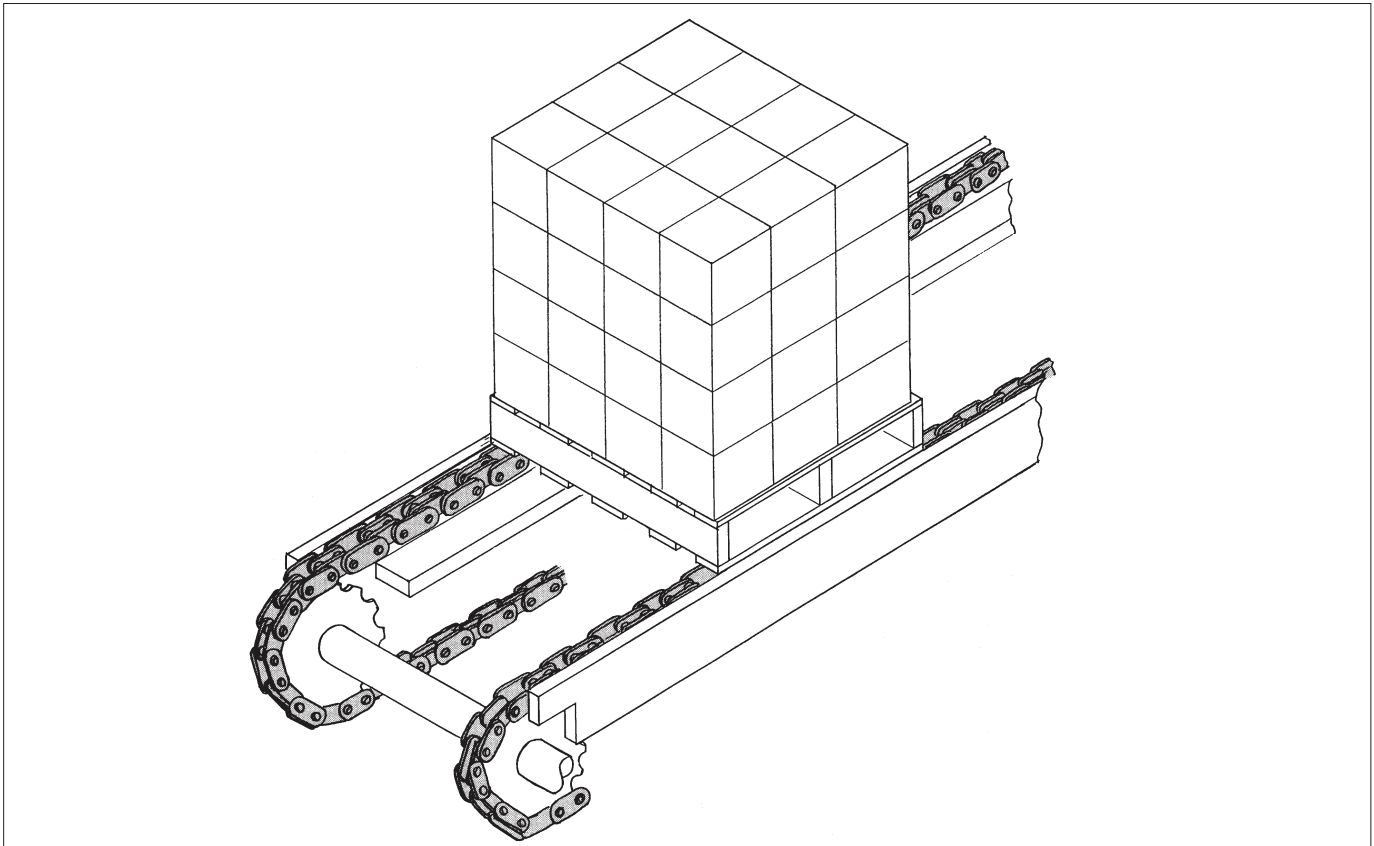

6. Engineering Information

When you design any of the various conveyor systems using a DID small sized roller chain for conveyor systems, the following basic conditions must be satisfied.

- a. Chain tension: The tensile strength acting on the chain must be positively smaller than the strength of the chain.
- b. Strength of loaded components of chain: The loads acting on attachments, rollers of base chain, top rollers, side rollers, etc. must be positively smaller than the strength of these component.

- c. Wear resistance life of chain: Lubrication conditions to ensure a sufficiently long wear life of the chain must be considered.
- d. Sag adjustment of chain: The sag of the chain must be kept optimum by a tensioner, take-up device, or guide, etc.
- e. Others: Prevention of rail wear, prevention of machine vibration, and other necessary factors must be considered.

General points of the above conditions are described below.

6-1 Calculation of chain tension

In general, at first tentatively determine the chain size to be used. (For this temporary decision, see “Tentatively determination of chain size” column. Then, obtain “theoretical chain tension T” (P. 109) based on the tentatively determined chain, and multiply it by “speed factor K”, to obtain “substantial chain tension Ta”. For safety, the substantial chain load must not be higher than the “maximum allowable load “ stated in the table of dimensions of respective chain.

Safety condition of chain tension

$$\boxed{\text{Substantial chain tension } T_a} = \boxed{\text{Theoretical chain tension } T} \times \boxed{\text{Speed factor } K}$$

$$\boxed{\text{Substantial chain tension}} < \boxed{\text{Maximum allowable tension}}$$

If this condition is not satisfied, raise the temporarily decided chain size by one size and re-calculate.

Tentative determination of chain size

- ① At first, assume that the mass (weight) ω_c {lbs/FT} per unit length of operational components such as chain and attachment as 10 % of the mass (weight) ω_1 {lbs/FT} of the conveyed object, to assume the unit (weight) of the operational components.
- ② From calculation formulas of P. 109, obtain “theoretical chain tension T” {lbs/FT} and “speed factor K”, and calculate “substantial chain tension Ta” {lbs}.
- ③ In reference to the table of dimensions of chain, identify the minimum chain, the “maximum allowable load” of which is not lower than the “substantial chain tension Ta”, as the “temporarily decided chain”.

Value of speed factor K

If the running speed of the chain is higher, the service condition is more severe for the chain. The speed factor expresses the severity.

Multiply the “theoretical tension” by the “speed factor K”, to obtain the “substantial chain tension”.



Speed factor K

Chain speed (FT/min)	Speed factor
Less than 49	1
49~98	1.2
98~164	1.4
164~230	1.6
230~295	2.2
295~360	2.8
360~394	3.2

In the case of resin rollers (including anti-static rollers), use the chain at 230 FT or less.

Note: When the chain speed exceeds 394 FT, please consult with us.

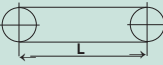
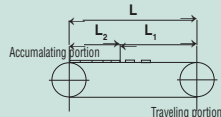
Calculation formulas of theoretical chain tension T

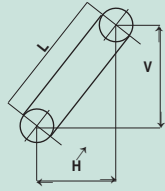
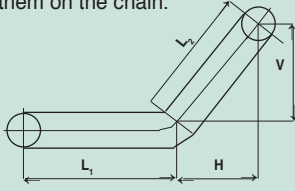
Conveying method	Calculation formulas of theoretical chain tension T	
	SI unit	Gravitational unit
To convey articles horizontally with them on the chain. 	$T = \{(W+2.1 \times \omega_c \times L) \times f_1 \times \frac{g}{1,000}\}$ $kW = \frac{T \times S}{54.6 \times \eta}$	$T = (W+2.1 \times \omega_c \times L) \times f_1$ $kW = \frac{T \times S}{30,000 \times \eta}$
To convey articles horizontally for accumulation (free from conveyor) 	$T = \{(\omega_1 + \omega_c) \times L_1 \times f_1 + \omega_2 \times L_2 \times f_2 + (\omega_1 + \omega_c) \times L_2 \times f_3 + 1.1 \times \omega_c \times L \times f_3\} \times \frac{g}{1,000}$ $kW = \frac{T \times S}{54.6 \times \eta}$	$T = (\omega_1 + \omega_c) \times L_1 \times f_1 + \omega_2 \times L_2 \times f_2 + (\omega_2 + \omega_c) \times L_2 \times f_3 + 1.1 \times \omega_c \times L_2 \times f_3\}$ $kW = \frac{T \times S}{30,000 \times \eta}$
To convey articles vertically. 	$T = \{(W + \omega_c \times V) \times \frac{g}{1,000}\}$ $kW = \frac{W \times S}{54.6 \times \eta}$	$T = W + \omega_c \times V$ $kW = \frac{W \times S}{30,000 \times \eta}$ Note: L = V in this method.
To convey articles on a slope with them on the chain. 	$T = \{(W + \omega_2 \times L) \times \frac{H \times f_1 + V}{L} + 1.1 \times \omega_c \times (H \times f_1 - V)\} \times \frac{g}{1,000}$ $kW = \frac{S}{54.6 \times \eta} \{T + \omega_c \times (H \times f_1 - V)\}$	$T = (W + \omega_2 \times L) \times \frac{H \times f_1 + V}{L} + 1.1 \times \omega_c \times (H \times f_1 - V)$ $kW = \frac{S}{30,000 \times \eta} \{T + \omega_c \times (H \times f_1 - V)\}$ <p>In the above, if $H \times f_1 - V < 0$, then assume $H \times f_1 - V = 0$. In the above, if $H \times f_1 - V > 0$, then assume $H \times f_1 - V = 0$.</p>
To convey articles on a slope and horizontal surface with them on the chain. 	$T = \left\{ \left(\frac{W}{L_1 + L_2} + 2.1 \times \omega_c \right) \times L_2 \times f_1 + \left\{ \left(\frac{W}{L_1 + L_2} + \omega_c \right) \times (H \times f_1 + V) + 1.1 \times \omega_c \times (H \times f_1 - V) \right\} \times \frac{g}{1,000} \right\}$ $kW = \frac{S}{54.6 \times \eta} \{T + \omega_c \times (H \times f_1 - V)\}$	$T = \left(\frac{W}{L_1 + L_2} + 2.1 \times \omega_c \right) \times L_2 \times f_1 + \left\{ \left(\frac{W}{L_1 + L_2} + \omega_c \right) \times (H \times f_1 + V) + 1.1 \times \omega_c \times (H \times f_1 - V) \right\}$ $kW = \frac{S}{30,000 \times \eta} \{T + \omega_c \times (H \times f_1 - V)\}$ <p>In the above, if $H \times f_1 - V < 0$, then assume $H \times f_1 - V = 0$. In the above, if $H \times f_1 - V > 0$, then assume $H \times f_1 - V = 0$.</p>

Meanings of symbols.

	SI units	Gravitational units
T	: Theoretical chain tension	kN (lbs)
W	: Total mass (total weight) of the conveyor	kg (lbs)
ω_1	: Mass (weight) of conveyed articles per unit machine length in the traveling portion	kg/m (lbs/ft)
	ω_1 = Total mass (total weight) of conveyed articles in the traveling portion {kg (or lbs for USA). Length traveling portion L1 (or ft for USA)}.	kg/m (lbs/ft)
ω_2	: Mass (weight) of conveyed articles per unit machine length in the accumulating portion	kg/m (lbs/ft)
	ω_2 = Total mass (total weight) of conveyed articles in the accumulating portion {kg (or lbs for USA). Length of accumulating portion L2 (or ft for USA)}.	m/min (ft/min)
ω_c	: Weight of operating components such as chain and attachments per unit length	
S	: Chain speed (traveling speed of chain)	
η	: Transmission mechanical efficiency of drive	
g	: Gravitational acceleration, 9.80665 m/s ²	
kw	: Required power	

- As unit symbols, SI units and gravitational units stated together. Parenthesized units are gravitational units. For the weight (lbs) as the mass (lbs), the same value is used.
- For L, L1, L2, V and H, see the illustrations showing conveying methods.
- For coefficients of friction f1, f2 and f3, see P. 110.

Values of coefficients of friction

f1: Coefficient of traveling friction of chain (the coefficient of friction is decided differently for the following three cases.)

- When the rollers of a chain roll on a rail Table 1
- When side rollers roll on a floor Table 2
- When plates slide on a rail as in the case of a flat plate type chain Table 3

Also, for f1 used for calculation of the traveling portion of a free flow conveyor, the same values are used.

Table 1

f1 used when the rollers of a chain roll			
Kind of chain		Lubrication	
		Not provided	Provided
Chain with iron rollers	{ S rollers	0.21	0.14
	{ R rollers	0.12	0.08
Chain with resin rollers	{ S rollers	0.12	
	{ R rollers	0.08	
Sintered bushing roller chain	{ S rollers	0.14	
	{ R rollers	0.08	

Table 2

f1 used when side rollers roll on a floor		
Kind of chain	Lubrication	
	Not provided	Provided
Chain with iron rollers	0.09	0.06
Chain with resin rollers	0.06	
Chain with anti-static resin rollers	0.06	
Chain with resin rollers and brakes	0.09	

Table 3

f1 used when the plates of a chain slide (in the case of iron rail)	
Without lubrication	0.3
With lubrication	0.2

f2 : Coefficient of friction acting between conveyed articles and chain in the accumulating portion of a free flow conveyor (that is, it is a frictional resistance acting when the side rollers or top rollers roll while being loaded with conveyed object. Table 4 shows the values.)

Table 4

Kind of side rollers or top rollers	Value of f2	
	Without lubrication	With lubrication
Iron rollers	0.09	0.06
Resin rollers	0.06	—
Anti-static resin rollers	0.06	—
Resin rollers with brakes	0.09	—

6-2 Strength of Loaded Components

The load of conveyed articles act on the attachments, top rollers, side rollers, etc. of a chain. Confirm that the strength of these load components is sufficient.

Various strength calculation methods are available for various chain use methods. Only the allowable loads of rollers of the base chain proper, top rollers and side rollers are shown.

Allowable loads per one roller of chain proper, top roller and side roller

Unit N(lbs)

Chain No. DID	Roller of base chain		Top roller		Side roller	
	Iron	Resin	Iron	Resin	Iron	Resin
RC40	156 (35.2)	—	156 (35.2)	49 (11)	156 (35.2)	49 (11)
RC2040	156 (35.2)	—	156 (35.2)	49 (11)	156 (35.2)	49 (11)
RC2042	627 (140.8)	196 (44)	156 (35.2)	49 (11)	156 (35.2)	117 (26.4)
RC50	225 (50.6)	—	225 (50.6)	68 (15.4)	225 (50.6)	68 (15.4)
RC2050	225 (50.6)	—	225 (50.6)	68 (15.4)	225 (50.6)	68 (15.4)
RC2052	989 (215.6)	294 (66)	225 (50.6)	68 (15.4)	225 (50.6)	137 (30.8)
RC60	372 (83.6)	—	372 (83.6)	107 (24.2)	372 (83.6)	107 (24.2)
RC2060H	372 (83.6)	—	372 (83.6)	107 (24.2)	372 (83.6)	107 (24.2)
RC2062H	1530 (345.4)	490 (110)	372 (83.6)	107 (24.2)	372 (83.6)	156 (35.2)
RC80	627 (140.8)	—	627 (140.8)	176 (39.6)	627 (140.8)	176 (39.6)
RC2080H	627 (140.8)	—	627 (140.8)	176 (39.6)	627 (140.8)	176 (39.6)
RC2082H	2540 (572)	882 (198)	627 (140.8)	176 (39.6)	627 (140.8)	—
RC100	912 (204.6)	—	912 (204.6)	294 (66)	912 (204.6)	294 (66)
RC2100H	912 (204.6)	—	912 (204.6)	294 (66)	912 (204.6)	294 (66)
RC2102H	3660 (822.8)	1270 (286)	912 (204.6)	294 (66)	912 (204.6)	—

ROLLER CHAIN &
DOUBLE PITCH CHAIN
FOR CONVEYOR SYSTEM

ENGINEERING
INFORMATION

Examples of support of conveyed object

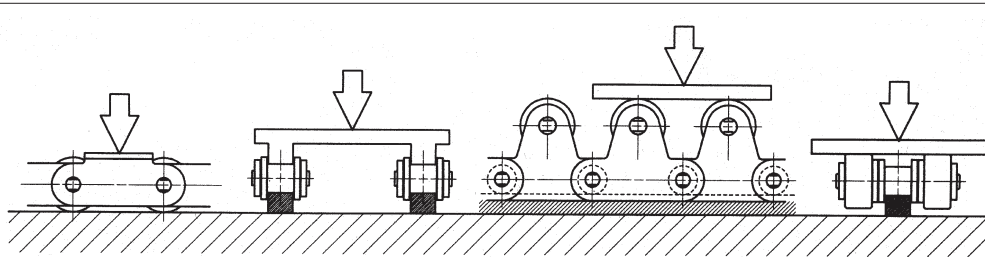

6-3 Wear Life of Small Sized Roller Chain

When wear of a chain cannot be avoided, the chain is a consumable product. However, if lubrication is practiced as much as possible, and if the calculation of 6-1 and 6-2 is practiced very carefully, there will be no practical problem.

See the maintenance of transmission chain (P. 73). If chain elongation occurs frequently, we recommend selection of the Ultimate Life Chain Series.

6-4 Adjustment of Chain Span and Other Maintenance

See "Installation, Adjustment and Maintenance (P. 70)

DID Products Which Are Not Covered in This Catalog

Specialty Roller Chain

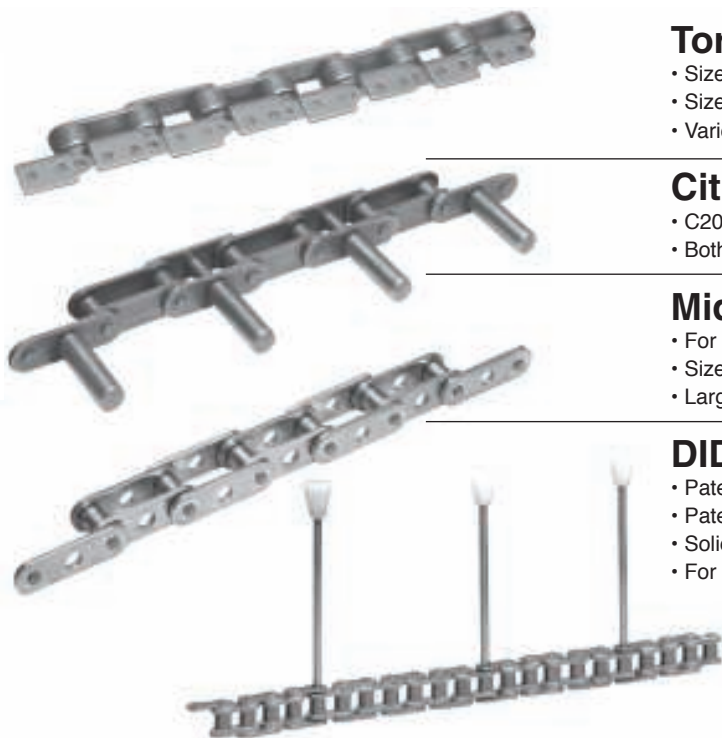

Tortilla Chain

- Sizes 40, 50, 60, 40-2, 50-2
- Sizes C2052, C2062H, C2082H
- Various attachments & hole diameters

Citrus Chain

- C2060H with D5 Extended Pin
- Both 1\2" & 9\16" pin diameters available

Mid-Pitch Hole Chain

- For wire belt conveyors
- Sizes 2050, 2060H, 2080H
- Large Roller sizes 2052, 2062H, 2082H

DID PIN OVEN CHAIN

- Patented X-Ring, O-Ring or Standard Chain
- Patented Spring Loaded Tip
- Solid Bushings
- For use in temperatures to 425°F

• ENGINEERING CLASS CHAIN

• MOTORCYCLE CHAIN

Motorcycle Drive Chain

• CONVEYOR SYSTEMS

Steel Handling Conveyor Systems
Bulk Handling Conveyor Systems
Material Handling Conveyor Systems
Control System of the Conveyor Systems
Coil Conveyors
Walking-Beams
Transfer Conveyors
Roller Tables
Down/Up Enders
Coil Car (CROSLOADER)
Transport Equipment
Bucket Elevator (NE Type: Normal Speed Type)
Bucket Elevator (NSE Type: High Speed Type)
Belt-Bucket Elevators
AEROBELT (Air Film Supported Belt Conveyor)
Continuous Flow Conveyors
Dust Conveyors
Pan Conveyors
Long Pan Conveyors
Apron Conveyors
Chain/Apron Feeders
Drag-Chain Conveyors
MOCVEYOR (Bulk Transport Conveyor for Adhesive Materials)
Auto-Motors (Auto Monorail Conveyor)
Power-And-Free Conveyors
Trolley Conveyor Systems
Drop/Table Lifters
Slat Conveyors
Tow-Line Conveyor Systems

Roller Conveyors

Free Flow Conveyors

Transport Systems for Garbage Transaction Plants

Other Transport Systems

• CONVEYOR PARTS

Safety Relay

Anti-Back Equipment

Take-Up Equipment

Various Casting

One Touch Window for Inspection (Dr. Window®)

• RIMS

Motorcycle Light Alloy Rims

Motorcycle Steel Rims

• SPOKES

Motorcycle Spokes

• WHEELS

Wheels for Agricultural Machinery

Wheels for Industrial Machinery

Small-Sized Wheels for Scooters

• ALUMINUM PRODUCTS

Motorcycle Aluminum-Alloy Swing Arms

• PLATED PRODUCTS

Aluminum Forming Products

Aluminum Welding Products

Aluminum Chrome Plating Products

Surface Treated Products

• AMENITY SYSTEMS

Stair Lifts for Wheel Chairs "JD Escal"

Stair Lifts for Wheel Chairs "Rakuchin-Go"

Product Index

DAIDO NO.	PAGE	DAIDO NO.	PAGE	DAIDO NO.	PAGE	DAIDO NO.	PAGE
RC25	14	RC240-5	27	RC180HK-2	40	RC120N	53
RC25-2	14	RA2040	28	RC180HK-3	40	RC140N	53
RC25-3	14	RA2050	28	RC200HK	40	RC160N	53
RC25-4	14	RA2060	28	RC200HK-2	40	RC25-E	54
RC25-5	14	RA2080	28	RC200HK-3	40	RC35-E	54
RC35	15	RA2100	28	RC240HK	40	RC40-E	54
RC35-2	15	RA2120	28	RC240HK-2	40	RC50-E	54
RC35-3	15	RC60H	28	RC240HK-3	40	RC60-E	54
RC35-4	15	RC80H	28	RC80HKSR	41	RC80-E	54
RC35-5	15	RC100H	28	RC100HKSR	41	RC100-E	54
RC41	16	RC120H	28	RC120HKSR	41	RC120-E	54
RC40	17	RC140H	28	RC140HKSR	41	RC40-WE	54
RC40-2	17	RC160H	28	RC160HKSR	41	RC50-WE	54
RC40-3	17	RC200H	28	RC180HKSR	41	RC60-WE	54
RC40-4	17	RC240H	28	RC200HKSR	41	RC80-WE	54
RC40-5	17	RC80K	29	RC240HKSR	41	RC100R-WE	54
RC50	18	RC100K	29	RC25HT	44	RC120R-WE	54
RC50-2	18	RC120K	29	RC35T	44	RC40R-TK	54
RC50-3	18	RC140K	29	RC40D	44	RC50R-TK	54
RC50-4	18	RC160K	29	RC50D	44	RC60-TK	54
RC50-5	18	RC180K	29	RC60D	44	RC80-TK	54
RC60	19	RC200K	29	RC80D	44	RC100-TK	54
RC60-2	19	RC240K	29	RC100D	44	RC120-TK	54
RC60-3	19	RC80KSR	31	RC25R-DHA	45	RC140-TK	54
RC60-4	19	RC80KSR-2	31	RC35R-DHA	45	RC160-TK	54
RC60-5	19	RC80KSR-3	31	RC41R-DHA	45	RC25SSR	55
RC80	20	RC100KSR	32	RC40R-DHA	45	RC35SSR	55
RC80-2	20	RC100KSR-2	32	RC50R-DHA	45	RC40SSR	55
RC80-3	20	RC100KSR-3	32	RC60R-DHA	45	RC50SSR	55
RC80-4	20	RC120KSR	33	RC35LLDR	47	RC60SSR	55
RC80-5	20	RC120KSR-2	33	RC40LLDR	47	RC80SSR	55
RC100	21	RC120KSR-3	33	RC50LLDR	47	RC100SSR	55
RC100-2	21	RC140KSR	34	RC60LLDR	47	RC120SSR	55
RC100-3	21	RC140KSR-2	34	RC80LDR	47	RC140SSR	55
RC100-4	21	RC140KSR-3	34	RC100LDR	47	RC160SSR	55
RC100-5	21	RC160KSR	35	RC120LDR	47	RC200SSR	55
RC120	22	RC160KSR-2	35	RC140LDR	47	RC40SR	55
RC120-2	22	RC160KSR-3	35	RC160LDR	47	RC50SR	55
RC120-3	22	RC180KSR	36	RC200LDR	47	RC60SR	55
RC120-4	22	RC180KSR-2	36	RC240LDR	47	RC80SR	55
RC120-5	22	RC180KSR-3	36	06BLDR	48	RC100SR	55
RC140	23	RC200KSR	37	08BLDR	48	RC40SLN	56
RC140-2	23	RC200KSR-2	37	10BLDR	48	RC50SLN	56
RC140-3	23	RC200KSR-3	37	12BLDR	48	RC60SLN	56
RC140-4	23	RC240KSR	38	16BLDR	48	RC80SLN	56
RC140-5	23	RC240KSR-2	38	06NLDR	48	RC65	59
RC160	24	RC240KSR-3	38	08NLDR	48	RC65L	59
RC160-2	24	RC50HK	39	10NLDR	48	RC15	60
RC160-3	24	RC60HK	39	12NLDR	48	RC15H	60
RC160-4	24	RC80HK	40	RC40UR	49	RC25	60
RC160-5	24	RC80HK-2	40	RC40URN	49	RC25H	60
RC180	25	RC80HK-3	40	RC50UR	49	RC25T	60
RC180-2	25	RC100HK	40	RC50URN	49	RC35	60
RC180-3	25	RC100HK-2	40	RC60UR	49	RC35T	60
RC180-4	25	RC100HK-3	40	RC60URN	49	AL422	61
RC180-5	25	RC120HK	40	RC80UR	49	AL444	61
RC200	26	RC120HK-2	40	RC80URN	49	AL466	61
RC200-2	26	RC120HK-3	40	RC25N	53	AL522	61
RC200-3	26	RC140HK	40	RC35N	53	AL544	61
RC200-4	26	RC140HK-2	40	RC41N	53	AL566	61
RC200-5	26	RC140HK-3	40	RC40N	53	AL588	61
RC240	27	RC160HK	40	RC50N	53	AL622	61
RC240-2	27	RC160HK-2	40	RC60N	53	AL644	61
RC240-3	27	RC160HK-3	40	RC80N	53	AL666	61
RC240-4	27	RC180HK	40	RC100N	53	AL688	61

ROLLER CHAIN &
DOUBLE PITCH CHAIN
FOR CONVEYOR SYSTEM

Product Index

ROLLER CHAIN &
DOUBLE PITCH CHAIN
FOR CONVEYOR SYSTEM

DAIDO NO.	PAGE	DAIDO NO.	PAGE	DAIDO NO.	PAGE	DAIDO NO.	PAGE
AL822	61	12B-3	63	RC2050LLDR	93	RC100-TR	99
AL844	61	16B	63	RC2052LLDR	93	RC40-2P-TR	99
AL866	61	16B-2	63	RC2060HLLDR	93	RC50-2P-TR	99
AL888	61	16B-3	63	RC2062HLLDR	93	RC60-2P-TR	99
AL1022	61	20B	63	RC40UR	94	RC80-2P-TR	99
AL1044	61	20B-2	63	RC40URN	94	RC100-2P-TR	99
AL1066	61	20B-3	63	RC50UR	94	RC40-2-2PTR-F	100
AL1088	61	24B	63	RC50URN	94	RC50-2-2PTR-F	100
AL1222	61	24B-2	63	RC60UR	94	RC60-2-2PTR-F	100
AL1244	61	24B-3	63	RC60URN	94	RC80-2-2PTR-F	100
AL1266	61	RC2040	85	RC80UR	94	RC100-2-2PTR-F	100
AL1288	61	RC2042	85	RC80URN	94	RC2040-TR	101
AL1444	61	RC2050	85	RC2040UR	95	RC2042-TR	101
AL1466	61	RC2052	85	RC2042UR	95	RC2050-TR	101
AL1644	61	RC2060H	85	RC2050UR	95	RC2052-TR	101
AL1666	61	RC2062H	85	RC2052UR	95	RC2060H-TR	101
BL423	61	RC2080H	85	RC2060HUR	95	RC2062H-TR	101
BL434	61	RC2082H	85	RC2062HUR	95	RC2080H-TR	101
BL446	61	RC2100H	85	RC2080HUR	95	RC2082H-TR	101
BL466	61	RC2102H	85	RC2082HUR	95	RC2100H-TR	101
BL523	61	RC2120H	85	RC2040URN	95	RC2102H-TR	101
BL534	61	RC2122H	85	RC2042URN	95	RC40HP	105
BL544	61	RC2160H	85	RC2050URN	95	RC50HP	105
BL546	61	RC2162H	85	RC2052URN	95	RC60HP	105
BL566	61	RC25	89	RC2060HURN	95	RC2040HP	105
BL623	61	RC35	89	RC2062HURN	95	RC2042HP	105
BL634	61	RC41	89	RC2080HURN	95	RC2050HP	105
BL644	61	RC40	89	RC2082HURN	95	RC2052HP	105
BL646	61	RC50	89	RC25SSR	96	RC2060HP	105
BL666	61	RC60	89	RC35SSR	96	RC2062HP	105
BL823	61	RC80	89	RC40SSR	96	RC2080HP	105
BL834	61	RC100	89	RC50SSR	96	RC2082HP	105
BL844	61	RC120	89	RC60SSR	96	RC40FX	106
BL846	61	RC140	89	RC80SSR	96	RC50FX	106
BL866	61	RC160	89	RC100SSR	96	RC60FX	106
BL1023	61	RC200	89	RC25SR	96	RC80FX	106
BL1034	61	RC40	90	RC35SR	96	RC35FR	107
BL1044	61	RC50	90	RC40SR	96	RC40FR	107
BL1066	61	RC60	90	RC50SR	96	RC50FR	107
BL1223	61	RC80	90	RC60SR	96	RC60FR	107
BL1234	61	RC100	90	RC80SR	96	RC80FR	107
BL1246	61	RC2040	91	RC100SR	96	RC100FR	107
BL1423	61	RC2042	91	RC2040SSR	97	RC120FR	107
BL1434	61	RC2050	91	RC2042SSR	97		
BL1446	61	RC2052	91	RC2050SSR	97		
BL1623	61	RC2060H	91	RC2052SSR	97		
BL1634	61	RC2062H	91	RC2060HSSR	97		
BL1646	61	RC2080H	91	RC2062HSSR	97		
04B	63	RC2082H	91	RC2080HSSR	97		
05B	63	RC2100H	91	RC2082HSSR	97		
05B-2	63	RC2102H	91	RC2040SR	97		
06B	63	RC2120H	91	RC2042SR	97		
06B-2	63	RC2122H	91	RC2050SR	97		
06B-3	63	RC2160H	91	RC2052SR	97		
08B	63	RC2162H	91	RC2060HSR	97		
08B-2	63	RC40LLDR	92	RC2062HSR	97		
08B-3	63	RC50LLDR	92	RC2080HSR	97		
10B	63	RC60LLDR	92	RC2082HSR	97		
10B-2	63	RC80LDR	92	RC40-TR	99		
10B-3	63	RC100LDR	92	RC50-TR	99		
12B	63	RC2040LLDR	93	RC60-TR	99		
12B-2	63	RC2042LLDR	93	RC80-TR	99		

Terms and Conditions of Sale

1. Price.

All prices on standard products are F.O.B. shipping point. All prices and discount schedules are subject to change without notice. The prices in effect on the date of shipment shall apply. Buyer shall also pay the increase in the cost of manufacture or increases resulting from any law, ordinance or regulation enacted or promulgated by any government or subdivision thereof, department, agency or other source after the date of this order but prior to the completion and delivery hereunder. All excise, sales, use, duties and other similar taxes applicable to this order and required to be collected by the Seller shall be added to the invoice unless an appropriate tax exemption certificate is received.

The minimum order is \$50.00.

2. Payment.

Terms of payment are net thirty (30) days. Overdue payments shall be subject to interest charges at the rate of 18% per annum. In the event of non-payment by the Buyer, the Buyer shall pay all of the Seller's costs of collection, including reasonable attorney's fees.

3. Acceptance, Cancellation and Delivery of Orders.

Price quotations not accepted by the Purchaser within thirty (30) days are subject to review and revision. All orders are subject to credit approval.

No contract between the Seller and Buyer shall be deemed to exist until the Buyer's order has been accepted by the Seller.

Orders are not subject to cancellation or revision, in whole or in part, without the prior written approval of the Seller.

Stated delivery times are approximate and delivery shall be deemed complete upon tender of goods to a common carrier. Seller may make delivery through partial shipments.

Subject to the prior written consent of Seller, changes may be made in the orders or the design or construction of the goods being made up or in process and deliveries may be extended beyond the delivery date, provided the Buyer reimburses and indemnifies Seller for costs and expenses incurred by reason of the delay or interruption of the progress of the work or the delay in delivery.

(D Shipment from Seller is F.O.B. shipping point, unless other transportation terms are specifically quoted by Seller. Special orders or "made-to-order" products, may be handled and delivered separately.

Buyer shall not be charged for normal boxing or crating required by the transportation company for domestic shipments. Special boxing, cartage to steamer or transfer expenses shall be added to the invoice unless such charges are indicated as included in the price quoted.

Seller shall not be liable for any delay caused by acts of God, riot, civil disobedience, governmental orders, rules, regulations, Suspensions or requisitions of any nature; labor shortage, stoppages, boycotts, lockouts or strikes, shortage of materials; fire, casualties, accidents or any other cause of the same or different nature beyond the control of Seller, or delays of Seller's subcontractors or suppliers in furnishing materials or supplies due to one or more of the foregoing clauses. Any such delay shall extend the time for delivery and shall not relieve Buyer of its obligations to accept remaining deliveries.

Buyer agrees to accept overruns of up to ten (10%) percent of the order on "made-to-order" products and parts. Additional items shall be priced at the price per item charged for the specific quantity ordered.

4. Title and Risk of Loss.

Title to all products and parts ordered and the risk of loss or damages shall pass to Buyer upon delivery of the goods to a carrier for shipment. Any claims for shortages or damages suffered in transit shall be made by the Buyer directly to the carrier.

5. Tooling, Specifications and Patterns.

Tool, die, drawing and pattern changes, if any, are in addition to the price of the product and are due and payable upon completion of the tooling. Tools, dies, patterns and drawings shall be the sole and exclusive property of the Seller and charges therefore do not convey title, a right to remove same from Seller's factory, or its vendor's factory nor prevent their use for other buyer's, except as may be specifically agreed upon, in writing, by Buyer and Seller.

6. Limited Warranty.

Seller warrants that its products are free from defects in material and workmanship under normal use, service and maintenance for a period of ninety (90) days after shipment and conform to any drawings and/or specifications furnished by the purchaser and agreed to by Seller, in writing and conform to any descriptions made by Seller in writing. The warranty shall not apply to any product or part of which has been subject to misuse, negligence, accident in shipping or handling, improper maintenance, used beyond the product's rated capacity, or in any otherwise improper manner, or which have been modified, altered or repaired by anyone other than the Seller.

SELLER MAKES NO WARRANTY THAT ITS PRODUCTS ARE FIT FOR A PARTICULAR PURPOSE OR THE PURPOSE TO WHICH THEY MAY BE PUT BY THE PURCHASER WHETHER OR NOT SUCH USE OR PURPOSE HAS BEEN DISCLOSED TO SELLER. THIS WARRANTY AS SET FORTH IS IN LIEU OF ALL OTHER WARRANTIES, EXPRESSED OR IMPLIED, INCLUDING THE IMPLIED WARRANTY OF MERCHANTABILITY OR FITNESS FOR PURPOSE. SELLER SHALL NOT BE LIABLE FOR ANY SPECIAL OR CONSEQUENTIAL DAMAGES ARISING OUT OF OR RELATED TO THE SALE OR USE OF ANY PRODUCT BASED ON CONTRACT OR TORT. PURCHASER WAIVES ALL OTHER REMEDIES, INCLUDING, BUT NOT LIMITED TO, DAMAGES RESULTING FROM PERSONAL INJURY, DEATH OR INJURY TO PERSONAL PROPERTY.

Purchaser expressly acknowledges that it is not relying on any advice, representations or warranties (except the warranties set forth above) of Seller; or upon Seller's skill or judgment regarding the products. Purchaser is solely responsible for the design and specifications of the products, including, but not limited to, the determination of suitability for purchaser's applications of the products.

Any claim relating to quantity or type shall be made to Seller in writing within ten (10) days after receipt of the product. Any claim under the limited warranty set forth above shall be made to Seller in writing within ninety (90) days after receipt of the products. Claims made after the above time periods shall be barred.

Seller's liability based upon warranty or otherwise for defective or non-conforming products shall be based upon Seller's examination confirming the claim following return of the products to Seller, transportation prepaid and shall be limited solely to repair or replacement, at Seller's option.

7. Indemnification.

Purchaser will indemnify, hold Seller harmless and, at Seller's option, defend Seller from all loss, liability, damage and expense, including attorneys' fees, arising out of any claim or in any way connected with the products or any items into which the products are incorporated, including, but not limited to, claims for product liability, whether based on contract or tort, breach of warranty, breach of contract or otherwise; or, by reason or claims for infringement of patents, trademarks, copyrights, misappropriation of trade secrets, unfair competition or similar charge resulting from products supplied by Seller in accordance with design or specifications furnished by Purchaser.

8. Returns.

Goods may only be returned with the Seller's prior written authorization. All returned goods must be shipped freight prepaid and must be in resalable condition. A minimum handling charge of twenty (20%) percent will be applied to all authorized returns. Special or "made-to-order" goods are not subject to return.

Daido Corporation



P.O. Box 7659
1031 Fred White Blvd.,
Portland, TN 37148
Tel: 615.323.4020
Fax: 615.323.4015
www.daidocorp.com



Daido Corporation of America's, Portland, TN Headquarters

Distributed by:

Note: To consistently improve our products, the specifications in this catalog are subject to change without notice