

# Product Specifications



*Designed for Quality*



**ROTOR CLIP®**

Price: \$2.00 U.S.

# ROTOR CLIP COMPANY, INC.<sup>®</sup>

® Certified to ISO/TS 16949 • ISO 9001 • AS9100 • ISO 14001



## **Rotor Clip<sup>®</sup>**

### **U.S.A. - World Headquarters**

187 Davidson Avenue, Somerset, NJ 08873 USA  
+1 732-469-7333 • Fax: +1 732-469-7898  
E-mail: sales@rotorclip.com • www.rotorclip.com

### **Czech Republic**

Pražská 403, CZ-411 18 Budyně nad Ohří, Czech Republic  
+420 416 863 168 • Fax: +420 416 863 193  
E-mail: rotorclipcz@rotorclip.com • www.rotorclip.cz

### **United Kingdom**

Unit 6, Meadowbrook Park, Holbrook, Sheffield, S20 3PJ United Kingdom  
+44 (0) 114 247 3399 • Fax: +44 (0) 114 247 4499  
E-mail: rcltd@rotorclip.com • www.rotorclip.co.uk

### **Germany**

Buchwiese 3, D-65510 Idstein/Taunus Germany  
+49 (0) 6126 227360 • Fax: +49 (0) 6126 2273619  
E-mail: rcgmbh@rotorclip.com • www.rotorclip.de

### **People's Republic of China**

Building 3, No. 338, Yingxiu Road, Qingpu District  
Shanghai 201700 People's Republic of China  
+86 21 31155558 • Fax: +86 21 31155556  
E-mail: china@rotorclip.com • www.rotorclip.com/China



# Table of Contents®

Product Index.....	2-3	<b>ANSI Metric Tapered Section Retaining Rings</b>		<b>TruWave® Wave Springs</b>	
Rotor Clip: Your Single Source.....	4	MHO.....	100-105	SST.....	208-209
Ring Attributes.....	5	MSH.....	106-109	NST.....	210
Part Numbers & Packaging.....	6	MSR.....	110-111	MST.....	211-212
rotorclip.com - Online Ordering.....	7	ME.....	112-113	MST Bearing Interchange.....	213
Materials: Tapered/Constant Section Rings.....	8	MC.....	114-115	WSL/WSM/WSR.....	214-223
Finishes: Tapered/Constant Section Rings.....	9	MRE.....	116-117	MWL/MWM/MWR.....	224-235
Materials/Finishes: Spiral Rings.....	10				
Wave Springs.....	11	<b>JIS “E” Retaining Rings</b>		<b>Shims</b>	
Hose Clamps.....	12	JE.....	118	KMS.....	236
Interchange Chart.....	13				
		<b>Inch Constant Section Retaining Rings</b>		<b>Self-Compensating Hose Clamps</b>	
<b>Inch Tapered Section Retaining Rings</b>		HN.....	119	HC.....	237
<b>(Axially Assembled)</b>		UHO.....	120-121	HW.....	238
HO.....	14-19	UHB.....	122-124	DW.....	239
SH.....	20-25	USC.....	125-127	CTB.....	240
HOI.....	26-27	USH.....	128	CTL.....	241
SHI.....	28-29	SNL.....	129		
SHR.....	30-31	SLC/SLO; SHC/SHO.....	130	<b>Tools/Kits</b>	
SHM.....	32-33	RLC/RLO; RHC/RHO.....	131	Standard Retaining Ring Pliers.....	242
BHO.....	34-35			Ratchet Retaining Ring Pliers.....	243
BSH.....	36-37	<b>Metric Constant Section Retaining Rings</b>		Grip Ring Pliers.....	243
VHO.....	38-43	HBL/HBM/HBH.....	132-133	Convertible Retaining Ring Pliers.....	244
VSH.....	44-47	SR.....	134	Heavy Duty Retaining Ring Pliers.....	244
		SB.....	135	Applicators & Dispensers.....	245-247
<b>Inch Tapered Section Retaining Rings</b>		CFS.....	136-138	Automatic Assembly Tools (Ring).....	248
<b>(Radially Assembled)</b>		CFH.....	139-142	XXL Retaining Ring Tool.....	248
E.....	48-49	CBS (DIN 5417).....	143-144	Hose Clamp Tools (Pneumatic).....	249
RE.....	50-51	CRS (DIN 7993 Type A).....	145	Hose Clamp Tools (Manual).....	249
C.....	52-53	CRH (DIN 7993 Type B).....	146	Retaining Ring Plier Kits.....	250
LC.....	54-55	Cutoff Styles.....	147	Retaining Ring Kits.....	250
PO/POL.....	56-57				
BE.....	58-59	<b>Inch Spiral Retaining Rings</b>		<b>Technical Information</b>	
EL.....	60-61	KL.....	148-149	Automated Assembly (Axial Rings).....	251
		CL.....	150-151	Load Capacity Formulas.....	252-259
<b>Inch Tapered Section Retaining Rings</b>		KM.....	152-155	Static Thrust Loads.....	252-255
<b>(Self-Locking)</b>		CM.....	156-159	Allowable Thrust Loads - Rings.....	252
SHF.....	62-63	KR.....	160-161	Allowable Thrust Loads - Grooves.....	252
RG.....	64	CR.....	162-163	Calculating Edge Margin.....	253
TX.....	65	KG.....	164-167	Thickness of Housings/Hollow Shafts.....	254
TY.....	66	CG.....	168-171	Load Limit Formulas.....	254-255
TI.....	67	KLR.....	172-173	Dynamic Thrust Loads.....	256-257
		CLR.....	174-175	Sudden Loading.....	256
<b>Metric Tapered Section Retaining Rings</b>				Impact Loading.....	256
DHO (DIN 472).....	68-75	<b>Metric Spiral Retaining Rings</b>		Vibration Loading.....	256-257
DHI.....	76-77	DKR (DIN 472).....	176-179	Corner Radii and Chamfers.....	257-258
DHT (DIN 984).....	78-79	DCR (DIN 471).....	180-181	Elastic Deformation.....	258
DHR (DIN 472 - Heavy Type).....	80	DKL.....	182-183	Relative Rotation.....	259
DSR (DIN 471 - Heavy Type).....	81	DCL.....	184-185	Deflection.....	259
DSH (DIN 471).....	82-89	KLM.....	186-187	Beveled Retaining Rings.....	260
DSI.....	90-91	CLM.....	188-189	Bowed Retaining Rings.....	261
DST (DIN 983).....	92-93	MKM.....	190-191	Inspection Procedures.....	262-264
DE (DIN 6799).....	94	MCM.....	192-193	Determining Permanent Set Limits.....	262
DSF.....	95	MKR.....	194-195	Dish, Pitch & Burr Limitations.....	263
DC.....	96-97	MCR.....	196-197	For Constant Section Retaining Rings.....	264
DTX.....	98	MKG.....	198-199	Constant Section Ring “Kick-In” Feature.....	264
DTI.....	99	MCG.....	200-201	Definitions (Retaining Ring).....	265
		MKA (Aerospace).....	202-203	Design Considerations (Retaining Ring).....	266-267
		MCA (Aerospace).....	204-205	Military Retaining Rings.....	268
				Lot Traceability / Quality.....	269
		<b>TruWave® Spiral Rings</b>		Joint Design Guide - Hose Clamps.....	270-271
		NKG.....	206		
		NCG.....	207		



# Product Index

## Axially Assembled, Inch Tapered Section Retaining Rings

Internal

External



**HO**  
Page 14-19



**HOI**  
Page 26-27



**BHO**  
Page 34-35



**VHO**  
Page 38-43



**SH**  
Page 20-25



**SHI**  
Page 28-29



**SHR**  
Page 30-31



**SHM**  
Page 32-33



**BSH**  
Page 36-37



**VSH**  
Page 44-47

## Radially Assembled, Inch Tapered Section Retaining Rings

External



**E/SE/  
YE/ZE**  
Page 48-49



**RE**  
Page 50-51



**BE**  
Page 58-59



**C**  
Page 52-53



**LC**  
Page 54-55



**PO/POL**  
Page 56-57



**EL**  
Page 60-61

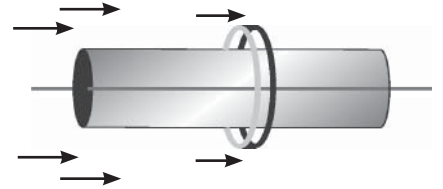

Axially Installed

## Self-Locking, Inch Tapered Section Retaining Rings

External

Internal



**SHF**  
Page 62-63



**RG**  
Page 64



**TX**  
Page 65



**TY**  
Page 66



**TI**  
Page 67

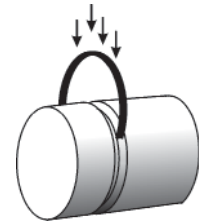

Radially Installed

## Axially Assembled, Metric Tapered Section Retaining Rings

Internal

External



**DHO**  
DIN 472  
Page 68-75



**DHI**  
Page 76-77



**DHT**  
DIN 984  
Page 78-79



**DHR**  
DIN 472  
Heavy  
Type  
Page 80



**DSH**  
DIN 471  
Page 82-89



**DSI**  
Page 90-91



**DST**  
DIN 983  
Page 92-93



**DSR**  
DIN 471  
Heavy  
Type  
Page 81

## Radially Assembled, Metric Tapered Section Retaining Rings

External



**DE**  
DIN 6799  
Page 94



**DC**  
Page 96-97

## Self-Locking, Metric Tapered Section Retaining Rings

External

Internal



**DSF**  
Page 95



**DTX**  
Page 98



**DTI**  
Page 99

## JIS "E" Retaining Rings

External



**JE**  
JIS B 2805  
Page 118

## Axially Assembled, ANSI Metric Tapered Section Retaining Rings

Internal External



**MHO**  
Page 100-105



**MSH**  
Page 106-109



**MSR**  
Page 110-111

## Radially Assembled, ANSI Metric Tapered Section Retaining Rings

External



**ME**  
Page 112-113



**MC**  
Page 114-115



**MRE**  
Page 116-117



## Inch Constant Section Retaining Rings

Internal

External

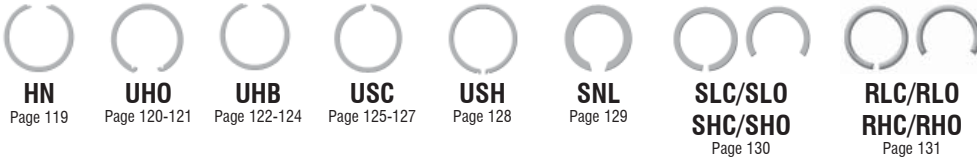

## Metric Constant Section Retaining Rings

Internal

External

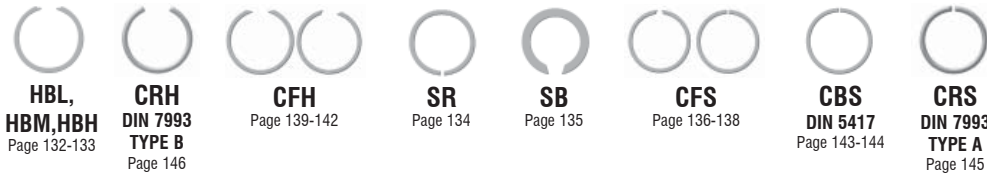

## Shims

Internal/External



## Inch Spiral Retaining Rings

Internal

External



## TruWave® Rings

Internal External



## Metric Spiral Retaining Rings

Internal

External

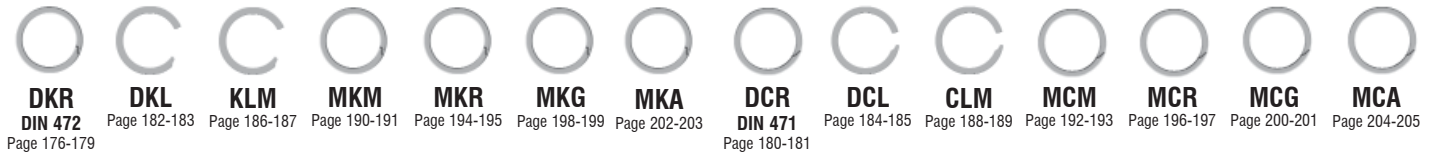

## TruWave® Wave Springs

Single Turn

Multi Turn

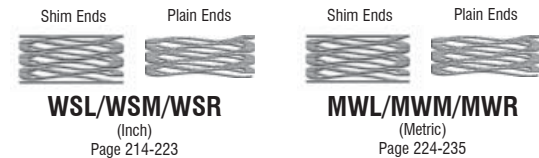

## Self-Compensating Hose Clamps

Wire Clamps

Band Clamps





## All Rings Have A Function...

A discussion of retaining rings must inevitably begin with a debunking of myths; namely, that one style retaining ring will function better than all other types in all instances. No one retaining ring style is “better” than another. Rather, the parameters of an application actually determine which retaining ring is best to use, and this can vary from assembly to assembly. Selecting the correct type of retaining ring based on variables such as installation/removal requirements, anticipated thrust load, and end play take-up can ensure the retaining ring you choose will perform reliably, while significantly reducing fastener costs.

There are three main types of retaining rings available to the designer: **tapered, constant section and spiral**. These are typically made from carbon steel, stainless steel or beryllium copper and feature a variety of finishes for corrosion protection (see accompanying table). Again, the final selection of a type and size retaining rings depends upon these and the previously mentioned parameters.

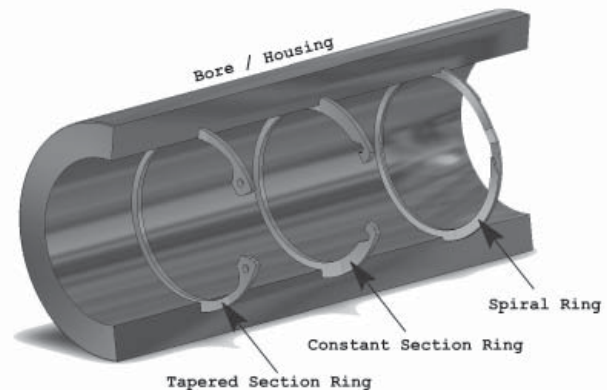

The following are some points to take into consideration when choosing a ring. Our engineers work with you to find the right type of ring for your design.



### TAPERED SECTION

Tapered section rings make uniform contact with the groove, with a gap between the lugs.



### CONSTANT SECTION

Constant section rings are elliptical when installed in the groove, making only 3-point contact as illustrated.



### SPIRAL RINGS

Spiral rings make 360° contact with the groove.

**For Technical Assistance,  
e-mail [tech@rotorclip.com](mailto:tech@rotorclip.com)**

## The Right Ring For Your Application



### **TAPERED SECTION RETAINING RINGS - Axially Assembled:**

- Axially installed into machined grooves in housings/bores (internal) or on shafts (external)
- Have lug holes for ease of installation/removal
- Make uniform contact when released in a groove
- Can accommodate higher thrust loadings
- Provide more of a shoulder with which to retain a component or assembly than constant section or spiral retaining rings



### **TAPERED SECTION RETAINING RINGS - Radially Assembled:**

- Radially installed into machined grooves on shafts (external)
- Accommodate lower thrust loadings than axial retaining rings
- Do not have lug holes: Easy to install using retaining ring applicators
- Provide protruding “shoulders” for effective retention of assemblies
- Economical alternative to Axially Assembled external tapered section rings

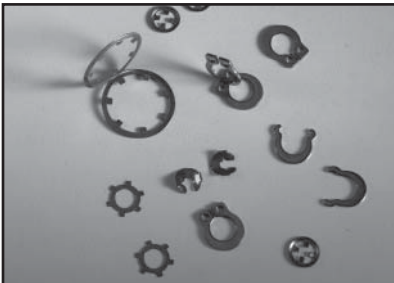

### **TAPERED SECTION RETAINING RINGS - Self Locking:**

- Can be installed on a shaft or in a housing/bore without a groove
- Save on machining time and costs since no groove is needed
- Can be used effectively and economically on small applications
- Accommodate low thrust loadings
- Difficult to remove once installed

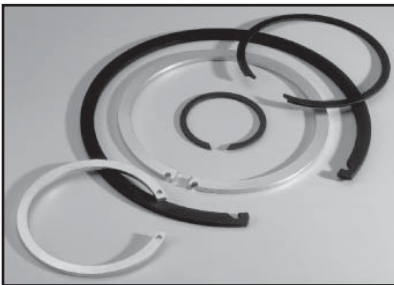

### **CONSTANT SECTION RETAINING RINGS:**

- Axially installed into machined grooves in housings/bores (internal) or on shafts (externally)
- Offer more clearance than a tapered section ring
- Accommodate less force than a tapered section ring
- Uniform material width is elliptical when installed in a groove, making 3 point contact
- More difficult to install/remove
- Economical alternative to tapered section rings depending on the application

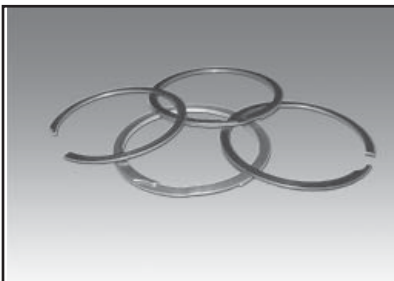

### **SPIRAL RETAINING RINGS:**

- Axially installed into machined grooves in housings/bores (internal) or on shafts (external)
- Make 360° contact with a groove in a housing/bore or shaft
- Accommodate less force than a tapered section ring
- Offer more clearance than a tapered section ring
- More difficult to install/remove



# Part Numbers & Packaging

## RETAINING RINGS

# HO-50ST PA S

**Identifies the ring TYPE** \_\_\_\_\_

**Identifies the ring SIZE** \_\_\_\_\_

**Identifies the ring MATERIAL** \_\_\_\_\_

**Denotes the ring FINISH** \_\_\_\_\_

**Denotes PACKAGING** \_\_\_\_\_

(Note: Bulk packaging has no code. Not all ring types can be stacked.)

### Materials Codes:

**ST** Carbon Steel  
**SS** Stainless Steel (PH15-7, PH17-7)  
**SG** Stainless Steel DIN 1.4122  
**SJ** Stainless Steel AISI 302  
**SU** Stainless Steel AISI 316  
**BC** Beryllium Copper  
**PB** Phosphor Bronze

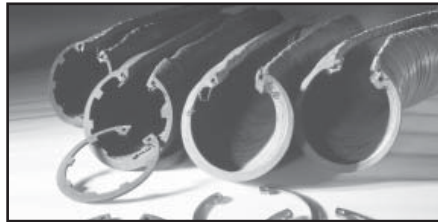

NOTE: **Rings on Wire, or ROW** (pictured above) is standard bulk packaging for certain rings. Contact factory for more details.

### Finishes Codes:

**PA\*** Phosphate  
**PD\*** Phosphate & Oil  
**PAL\*** Phosphate with Sealer  
**HPD\*** Heavy Phosphate & Oil  
**ZD** Zinc Dichromate  
**ZDL** Zinc Dichromate with Sealer  
**ZF** Zinc Bright  
**Z3X\*** Trivalent Chromate Zinc Plus Sealer  
**OIL\*** Oil Over Steel (Constant Section Rings)  
**ZFF\*\*** Zinc Flash  
**CF\*\*** Copper Flash

\* These finishes are RoHS compliant.

\*\* For identification only. Does not provide corrosion protection.

### Packaging Codes:

**No Code** Bulk  
**S** Tape Stacked  
**R01** Plastic Shrink Wrapped  
**W01** Rod Stacked

## WAVE SPRINGS

# WSL-50ST AF OIL

**Identifies the spring TYPE** \_\_\_\_\_

**Identifies the spring SIZE** \_\_\_\_\_

**Identifies the spring MATERIAL** \_\_\_\_\_

**\* Identifies the number of spring TURNS** \_\_\_\_\_

**\*\* Designates a FLAT SHIM END** \_\_\_\_\_

**Identifies the spring FINISH** \_\_\_\_\_

\* Alphabetic designation for the number of turns according to catalog specifications. A, B, C, D...

\*\* Designation to specify a Flat Shim End multi-turn wave spring. No code for a plain end multi-turn wave spring.

### Materials Codes:

**ST** Carbon Steel  
**SQ** Stainless Steel (17-7 PH/C)

### Special Material Grades:

AISI 302 Stainless • AISI 316 Stainless • A286  
 Inconel X-750 • Elgiloy • Hastelloy C276 • Beryllium-Copper  
 Phosphor-Bronze  
*(Available upon request.)*

### Finishes Codes:

**OIL\*** Oil Dipped  
**No Code\*** Vapor Degreased & Ultrasonic Cleaned  
 (Stainless Steel)

**SPP** Passivate  
**BO** Black Oxide  
**PD** Phosphate  
**ETM** Vibratory Deburr

\* Standards





## Place Your Order Online:

**www.rotorclip.com**

You can choose to use the automated check out feature in department stores and grocery markets. Why shouldn't you be able to automate your industrial purchases?

Now you can. As a current/prospective customer, Rotor Clip invites you to take advantage of our online ordering system to help you reduce your transaction costs and to make important information like order status, availability and quote status available to you when you want to see it. No need to make a phone call or wait for a customer service person to lookup your information. It can be available to you 24/7 on your computer.

To get things started, simply e-mail the name(s), e-mail addresses and location of the person(s) who would like to use the system to [cs@rotorclip.com](mailto:cs@rotorclip.com). We'll then set up an account, and e-mail login information to each. The system is pretty intuitive and you should be able to start using it immediately. However, if there are any questions, you can always contact Rotor Clip for help (+1 732-469-7333.)

### "DOUBLE ENTRY" NOT A PROBLEM

No need to be concerned about "double entry"...having to enter the order into your system and ours. A simple conversation between our respective IT departments should solve this issue, usually by arranging to transmit a flat file. This eliminates the need to enter the order twice into our respective systems.



With Rotor Clip's online ordering system you can check stock and availability as well as place your order. You can also check the status of your order, submit, view or print quotes, and view and print invoices.

**TO SIGN UP FOR ROTOR CLIP ONLINE ORDERING  
CALL +1 732-469-7333 OR E-MAIL [CS@ROTORCLIP.COM](mailto:CS@ROTORCLIP.COM)**



# Materials Tapered/Constant Section Rings

Standard material for Rotor Clip retaining rings is carbon spring steel (SAE 1060-1090/UNS G10600-G10900). Rings can also be produced in our standard stainless steel (PH 15-7 Mo/UNS S15700) with DIN 1.4122 as an option, and in our standard beryllium copper (Alloy #25/UNS C17200) with phosphor bronze (Alloy#5218/UNS C52180) as an option.

Please note that the availability of rings in the stainless steel and copper materials is subject to prior inquiry and acceptance of a formal quotation. Rotor Clip can also produce rings one gauge thicker or thinner than standard sizes. Again, such orders are subject to prior inquiry and acceptance of a formal quotation.

Characteristics of each material follow:

**CARBON SPRING STEEL** - This steel is known for its high strength, and reliability in retaining ring applications. Since carbon spring steel is subject to corrosion, Rotor Clip treats all such rings with a protective coating to ensure some corrosion resistance. For long-term corrosion protection, a zinc plating or non-metallic finish should be applied over the steel. (See "Finishes" section).

### STAINLESS STEEL -

• **PH 15-7 Mo** is an extra strength corrosion-resistant steel, capable of preventing atmospheric oxidation at temperatures up to 900° F. It also offers the following advantages:

1. Minimal distortion due to unique heat-treating process.
2. A minimum of 225,000 psi for high ultimate tensile strength.
3. High creep strength.

*Note: We reserve the right to substitute PH 17-7 stainless steel material for PH 15-7 Mo on larger rings.*

• **TYPE 420** - A less expensive alternative to PH 15-7. Since general corrosion resistance for this material is less than PH 15-7, use of this material depends upon the application. Contact Technical Sales for assistance.\*\*

• **DIN 1.4122** - A grade of stainless steel commonly used on DIN standard retaining rings.

**BERYLLIUM COPPER ALLOY#25** - Applications that require conductivity are best served by this material. It is also characterized by excellent corrosion resistance and is particularly effective in sea air and seawater atmospheres.

**PHOSPHOR BRONZE ALLOY#5218** - The least expensive copper material Rotor Clip offers. This type exhibits higher strength compared to standard phosphor bronze materials with the same tin percentages. It is also characterized by very good stress relaxation characteristics. (Note: Rotor Clip can also supply phosphor bronze material to DIN standard 17 662, Material Number 2.1020. Contact Rotor Clip Technical Sales for more information).

Material	Rotor Clip Code
<b>Carbon Spring Steel</b> SAE 1060-1090 (UNS G10600-G10900)	<b>ST</b>
<b>Stainless Steel</b> PH 15-7 Mo (Grade 632 - UNS S15700) 17-7 PH (Grade 631 - UNS S17700) 420 (UNS S42000) DIN 1.4122	<b>SS</b> <b>SS*</b> <b>SC**</b> <b>SG</b>
<b>Beryllium Copper</b> UNS C17200	<b>BC</b>
<b>Phosphor Bronze</b> UNS C52180	<b>PB</b>

\*Note: Large stainless steel rings may be supplied from 17-7 due to material availability. Contact factory for details.

\*\*Limited availability. Contact factory for details.

## TEMPERATURE LIMITS FOR TAPERED SECTION RETAINING RINGS

Material	Ring Series & Size Range					Temp. Limits	
	HO, VHO HOI, DHO	SH, VSH SHI, DSH	BHO, BSH LC, SHR	PO SHM C	RG, TI, TX SHF, EL DTX, DTI	MAX.F°	MIN.F°
Carbon Spring Steel (SAE 1060-1090)	ALL SIZES THROUGH-300	ALL SIZES THROUGH-343	ALL SIZES WHERE AVAILABLE	-	-	500	-100
	ALL DHO ALL SIZES -306 & OVER	ALL DSH ALL SIZES -350 & OVER	ALL DE & JE	ALL SIZES WHERE AVAILABLE		600	-100

This chart is for reference only. For information regarding performance of a retaining ring in a specific application, please contact technical sales: tech@rotorclip.com. Note: Temperature limits for all sizes of beryllium copper retaining rings (Alloy #25) are 650°F to -300°F. Temperature limits for all sizes of stainless steel retaining rings (PH 15-7 Mo or equivalent; AISI 632-AMS 5520) are 900°F to -100°F. For other materials, please contact Rotor Clip technical sales.



# Tapered/Constant Section Rings **Finishes**



**PHOSPHATE COATING (PA)** - This standard finish is recommended over unfinished plain steel since it offers an extended shelf-life protection against rusting. RoHS compliant. **THERE IS NO ADDITIONAL CHARGE FOR THIS FINISH.**

**PHOSPHATE AND OIL (PD)** - This finish provides 8-hour salt spray protection. RoHS compliant.

**PHOSPHATE WITH SEALER (PAL)** - A coating is added to the finish to control loose phosphate crystals on the surface of the part. RoHS compliant.

**HEAVY PHOSPHATE AND OIL (HPD)** - This finish provides 72 salt spray hours and can be used in place of costly stainless steel material in some applications. (Contact Rotor Clip Technical Sales for more information). RoHS compliant.

**ZINC PLATING (ZD)** - This coating features a yellow dichromate post plating finish. It affords the metal excellent salt spray protection (96 hours) and is particularly effective for applications exposed to seawater. Rotor Clip SAE 1060-1090 steel retaining rings are zinc plated using a mechanical plating process, which effectively eliminates hydrogen embrittlement.

**ZINC BRIGHT (ZF)** - Most of the dichromate is leached out of this process, leaving a “bright” silver finish on the parts. ZF offers some corrosion protection (48 hours), but is widely used when the aesthetics of the part are a factor.

**ZINC DICHROMATE w/SEALER (ZDL)** - This improved finish offers corrosion protection of up to 240 hours of salt spray protection. **(Heavy Zinc Dichromate with Sealer - HZDL** - offers 480 hours of salt spray protection.) It is a low cost substitution for costly non-corrosive materials such as stainless steel in some applications. Call for additional information.

**TRIVALENT CHROMATE over ZINC (Z3X)** - This coating meets global requirements for hexavalent-free coatings. **Z3X**, trivalent with a sealer, affords 240 salt spray hours of protection. RoHS & ELV compliant.

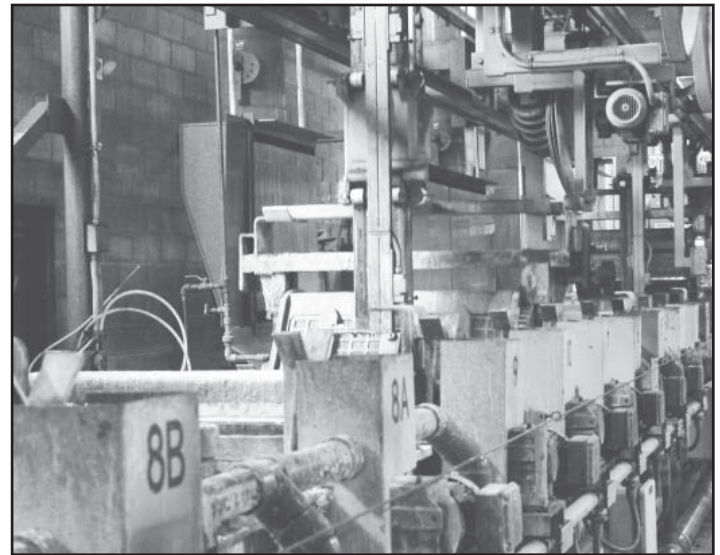

**GALVANIC ZINC PLATING (GZN)** - This plating has a thickness of 5-8 $\mu$ m and blue chromate conversion coat. RoHS compliant. **GZY** is a yellow chromate conversion coat with the same thickness and contains hexavalent chromium. NOT RoHS compliant. Both provide 72 hours salt spray protection (red rust.) Available for certain global markets only.

**OIL OVER STEEL (OIL)** - Used for Constant Section Rings, an oil finish is applied over carbon steel to offer an extended shelf-life protection against rusting. No salt spray protection. RoHS compliant.

Finish	Code	Description	Salt Spray Hours	Color
Phosphate	PA	Shelf-Life	-	Black
	PD	Phosphate and Oil	8 (Red Rust)	Black
	PAL	Phosphate with Sealer	-	Black
	HPD	Heavy Phosphate and Oil	72 (Red Rust)	Black
Hexavalent Chrome	ZF	Zinc Bright	48 (Red Rust)	Silver
	ZD	Zinc Dichromate	96 (Red Rust)	Yellow
	ZDL	Zinc Dichromate Sealer	240 (Red Rust)	Yellow
	HZDL	Heavy Zinc Dichromate Sealer	480 (Red Rust)	Yellow
Trivalent	Z3X	Trivalent Chromate Zinc plus Sealer	96/240*	N/A
Galvanic Zinc Plating	GZN	Galvanic Zinc Plating - Blue Chromate	48/72*	Silver
	GZY	Galvanic Zinc Plating - Yellow Chromate	48/72*	Yellow
Optional Color Coding Finishes	ZFF	Zinc Flash	None	Silver
	CF	Copper Flash	None	Copper
	OIL	Oil Over Steel - Shelf Life	-	Black

\* White Corrosion/Red Corrosion





# Materials/Finishes Spiral Rings

## Materials:

### CARBON SPRING STEEL (ST)

This steel is known for its high strength and reliability in spiral ring applications. Since carbon steel is subject to corrosion, Rotor Clip rings are oil dipped to ensure some corrosion resistance.

### STAINLESS STEEL - AISI 302 (SJ)

This general purpose stainless steel offers corrosion resistance and can be cold worked to high tensile strengths.

### STAINLESS STEEL - AISI 316 (SU)

This type of stainless steel is heat resistant with superior corrosion resistance than other chromium nickel steels. It offers high creep strength at elevated temperatures and resistance to pitting.

### STAINLESS STEEL - PH17-7 (SS)

A high strength corrosion-resistant steel with good workability, easy hardening and excellent mechanical properties at elevated temperatures. Can be heat treated at relatively low temperatures for high strength properties.

### BERYLLIUM COPPER (BC)

Applications that require conductivity are best served by this material. It is also characterized by excellent corrosion resistance and is particularly effective in sea air and seawater atmospheres

## Finishes:

### OIL DIP

This standard finish for carbon steel spiral retaining rings offers an extended shelf-life protection against rusting.

### PASSIVATION

The passivation process removes “free iron” contamination left behind on the surface of stainless steel due to the manufacturing process. Also, the passivation process facilitates the formation of a thin, transparent oxide film that protects the stainless steel from selective oxidation (corrosion).

### ZINC PHOSPHATE

This coating provides basic shelf life protection for single turn spiral rings (only.)

Material	Material Thickness (in)	Minimum Tensile Strength (psi)	Shear Strength (psi)	Maximum Recommended Operating Temperature °F	Modulus of Elasticity (psi)
CARBON STEEL OIL TEMPERED SAE 1070 - 1090	.006 - .014	269,000	153,000	250	30 x 10 <sup>6</sup>
	.0141 - .021	255,000	145,000		
	.0211 - .043	221,000	126,000		
	.0431 & larger	211,000	120,000		
CARBON STEEL HARD DRAWN SAE 1060 - 1075	.006 to .030	230,000	130,000	400	28 x 10 <sup>6</sup>
	.0301 - .110	181,000	103,000		
	.1101 - .220	156,000	89,000		
AISI 302 AMS-5866	.002 - .022	210,000	119,000	400	28 x 10 <sup>6</sup>
	.0221 - .047	200,000	114,000		
	.0471 - .062	185,000	105,000		
	.0621 - .074	175,000	100,000		
	.0741 - .089	165,000	94,000		
	.0891 - .095	155,000	88,000		
AISI 316 ASTM A313	.002 - .023	195,000	111,000	400	28 x 10 <sup>6</sup>
	.0231 - .048	190,000	108,000		
	.0481 - .061	175,000	99,000		
	.0611 & larger	170,000	97,000		
17-7 PH/C CONDITION CH900 AMS-5529		240,000 <sup>2</sup>	137,000 <sup>2</sup>	650	29.5 x 10 <sup>6</sup>
BERYLLIUM COPPER TEMPER TH02 ASTM B197		185,000 <sup>2</sup>	128,000 <sup>2</sup>	400	18.5 x 10 <sup>6</sup>



# Wave Springs **TRU**WAVE<sup>®</sup>

## Wave Spring Advantage

TruWave flat wire wave springs help to save up to 50% of axial space in your application when compared to conventional coil springs. The result is more compact applications in which unnecessary space and therefore excess material of neighboring components can be reduced to a minimum. The flat wire effectively reduces the solid height of the wave spring so that with the same amount of turns one can visibly reduce the work height without compromising the load or spring deflection. Another advantage is that one can increase the number of turns of the spring design in order to decrease the deflection per turn when the wave spring is compressed.

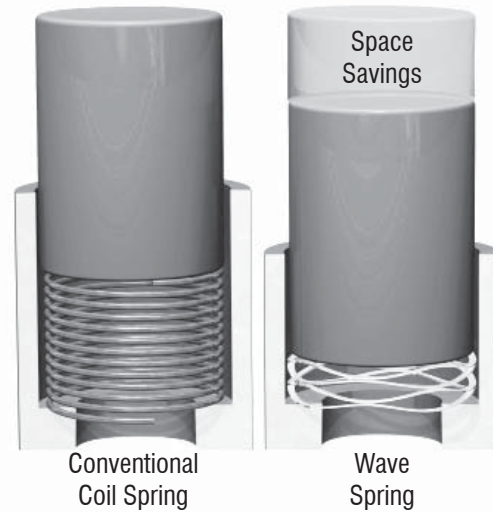

## WAVE SPRING TYPES:

### GAP SINGLE TURN/OVERLAP SINGLE TURN



*Standard Inch (SST) / Narrow Inch (NST) / Metric (MST)*

- Ideal for short deflection applications with low to medium forces.
- Offered in a number of waves and material thicknesses.
- Designed for a wide range of bore and rod diameters.
- Ideal for:
  - Narrow radial wall dimensions
  - Light duty applications
  - Low clearance applications
  - Ball or roller bearing applications

### MULTI-TURN PLAIN ENDS/MULTI-TURN SHIM ENDS

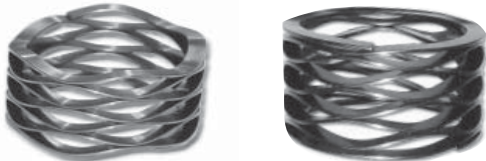

*Light (WSL-MWL) / Medium (WSM-MWM) / Heavy (WSR-MWR)*

- Decreasing spring rate is proportional to the number of turns: More turns equals less force.
- Used for low force applications with large deflections.
- Utilizes nearly 1/2 the space as helical compression springs while producing the same force.
- Ideal for:
  - Medium & heavy duty applications
  - High thrust load capacity
  - Light & medium bearing series: double row, tapered bearing depending on the spring version.

## WAVE SPRING MATERIALS:

Each application offers different operating conditions for a flat wire wave spring. Choosing the right material depends on operating temperature, contact with corrosive environments and the required number of load cycles. Rotor Clip's engineers will help you find the right material for your application. An overview of the materials used by Rotor Clip for flat wire wave springs can be found here:

### Standard Material Grades

#### SAE 1070-1090 Carbon Steel ( 1.1231 - 1.1273 )

- This pre hardened material is the standard material for wave springs.
  - Less expensive option to Stainless Steel.
- #### 17-7 Stainless Steel ( 1.4568 – X7CrNiAl17-7 )
- Used for high stress and fatigue applications.
  - Can withstand much higher temperatures than SAE 1070-1090 and not lose its spring qualities.
  - Higher corrosion resistance than SAE 1070-1090.

### Special Material Grades

- AISI 302 Stainless (DIN Material No.: 1.4319)
- AISI 316 Stainless (DIN Material No.: 1.4401)
- A286 (DIN Material No.: 1.4980)
- Inconel X-750 (DIN Material No.: 2.4669)
- Elgiloy (DIN Material No.: 2.4711)
- Hastelloy C276 (DIN Material No.: 2.4819)
- Beryllium-Copper (DIN Material No.: 2.1247)
- Phosphor-Bronze (DIN Material No.: 2.1030)

To have Rotor Clip design engineers help you custom design a wave spring for your particular application, fill out the Custom Wave Spring Design Form available at [rotorclip.com/wave\\_spring\\_design\\_form](http://rotorclip.com/wave_spring_design_form) or use our online custom wave spring calculator on [rotorclip.com/wsc](http://rotorclip.com/wsc).





# Hose Clamps Self-Compensating

## For Low Pressure Applications, Clamp It With Rotor Clamp

Rotor Clamp, Inc. produces a line of self-compensating hose clamps for low-pressure applications in single wire, double wire and constant tension band (CTB) configurations, including light band and narrow band clamps.

Self Compensating Hose Clamps simplify assembly/disassembly, reduce production time and lower costs. Ideal for replacing traditional screw/worm type clamps on low-pressure applications. Clamps also are a good alternative to gluing hoses to manifolds in spa applications, providing extremely effective clamping without the use of messy glues that could potentially clog the hose line.

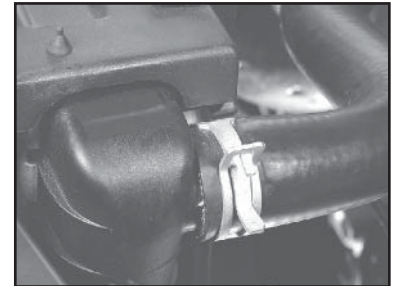

### Rotor Clamp Self-Compensating Hose Clamp

- Expands/Contracts with hose in response to temperature changes.
- Cannot be over/under tightened.
- Can be installed automatically eliminating Carpal Tunnel Syndrome (CTS), a nerve disorder of the hand and wrist.
- Less time for assembly lowering production cost.

### Competition Screw/Worm Type Clamp

- Must be manually adjusted as temperature changes
- Screw mechanism may be over/under tightened causing damage/leakage to the hose.
- Must be manually installed.
- More time needed for assembly/disassembly due to screw adjustment.



Single Wire (HC/HW)



Double Wire (DW)



Constant Tension Band (CTB)



Constant Tension Light Band (CTL)



# Interchange Chart

Rotor Clip Products May Be Used Interchangeably  
With The Part Numbers Indicated Below.

## INCH RETAINING RINGS

ROTOR CLIP®	Waldes Truarc®	IRR®	Anderton	Mil Standard
HO	N5000	3000	N1300	16625
HOI	5008	4000	N1308	16627
BHO	N5001	3001	1301	16629
VHO	N5002	-	N1302	16631
SH	5100	3100	N1400	16624
SHI	5108	4100	N1408	16626
SHR	5160	7200	N1460	3217
SHM	5560	-	-	-
BSH	5101	3101	1401	16628
VSH	5102	-	1402	16630
E	5133	1000	N1500	16633
RE	5144	1200	N1540	3215
BE	5131	1001	N1501	16634
C	5103	2000	N1800	16632
PO	5304	-	-	-
POL	T5304	-	-	-
EL	5139	-	-	3216
LC	5107	-	-	90708
SHF	5555	7100	N1440	90707
RG	5135	-	-	-
TX	5115	-	N1465	-
TY	5105	6100	N1405	-
TI	5005	R6000	N1305	-

## SPIRAL RINGS/SHIMS

ROTOR CLIP®	Spirolox®	Smalley®	Mil Standard
KL	UR	VH	-
CL	US	VS	-
KM	RR	WH	MIL-DTL-27426/3
CM	RS	WS	MIL-DTL-27426/1
KR	RRT	WHT	-
CR	RST	WST	-
KG	RRN	WHM	MIL-DTL-27426/4
CG	RSN	WSM	MIL-DTL-27426/2
DKR	-	DNH	-
DCR	-	DNS	-
DKL	-	FH	-
DCL	-	FS	-
KLR	-	FHE	-
CLR	-	FSE	-
MKM	ZRM	-	-
MCM	ZSM	-	-
MKR	ZRT	-	-
MCR	ZST	-	-
MKG	ZRH	-	-
MCG	ZSH	-	-
KLM	-	VHM	-
CLM	-	VSM	-
MKA	-	EH	-
MCA	-	ES	-
NKG	-	WHW	-
NCG	-	WSW	-
KMS	-	SSRS	-

## METRIC RETAINING RINGS

ROTOR CLIP®	Seeger®	Anderton	Ochiai
DHO DIN 472	J	D1300	-
DHI	JV	M1308	-
DHT DIN 984	JK	D2000	-
DHR	JS	D1360	-
DVH	JB	-	-
DSH DIN 471	A	D1400	-
DSI	AV	M1408	-
DST DIN 983	AK	D2100	-
DSR	AS	D1460	-
DVS	-	-	-
DE DIN 6799	RA	D1500	-
DC	H	M1800	-
DTX	ZA	M1465	-
DTI	ZJ	M1305	-
JE (JIS B 2805)	-	-	ETW

## WAVE SPRINGS

ROTOR CLIP®	Spirolox®	Smalley®
SST	TR/TB	SSR
NST	-	SSR Size-N
MST	TR/TB	SSB
WSL	CML	C/CS
WSM	CMM	C/CS
WSR	CMH	C/CS
MWL	-	CM/CMS
MWM	-	CM/CMS
MWR	-	CM/CMS

## RETAINING RING MATERIAL & PROCESS CODES

MATERIAL	ROTOR CLIP®	Waldes Truarc®	Anderton	IRR®	Smalley®
CARBON STEEL	ST	S	CS	ST	(NO CODE)
STAINLESS STEEL	SS	H	AS	SS2	S17
BERYLLIUM COPPER	BC	C	BC	BC	BEC
FINISHES	ROTOR CLIP®	Waldes Truarc®	Anderton	IRR®	Smalley®
PHOSPHATE	PA	PP	-	PA	PS
ZINC DICHROMATE	ZD	ZD	ZX	ZD	-
ZINC DICHROMATE LACQUER	ZDL	-	-	-	-
ZINC BRIGHT	ZF	ZF	ZE	-	-
PACKAGING	ROTOR CLIP®	Waldes Truarc®	Anderton	IRR®	Smalley®
BULK	(NO CODE)	B	BULK	BULK	(NO CODE)
STACKED	S	R (ROL-PAK)	STACKED	STACKED	-

Additional materials, finishes and packaging are available. Visit [rotorclip.com](http://rotorclip.com) or contact the factory.





# HO Housing Rings

## Axially Assembled, Internal

Once installed in the groove of a housing/bore, the portion of the ring protruding from the groove (also called a "shoulder") holds an assembly in place.

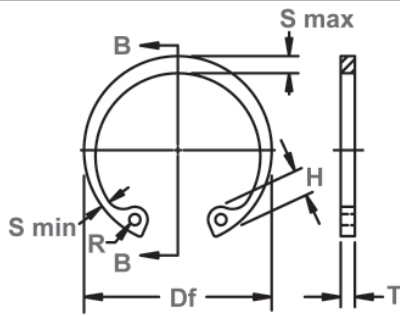

Free Diameter & Ring Measurements with Section B-B

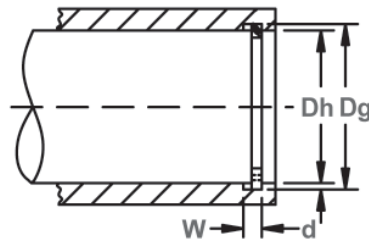

Housing Diameter & Groove Dimensions

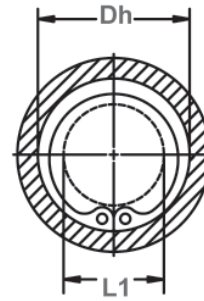

Clearance Diameter Compressed in Housing

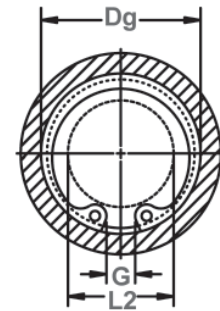

Clearance Diameter & Gap Width Released in Groove

RING NO.	HOUSING DIAMETER			GROOVE SIZE			RING SIZE & WEIGHT					CLEARANCE DIA.			i THRUST LD. (lbs.) Sgr. corner abutment		
				DIAMETER		WIDTH	DEPTH	FREE DIAMETER		THICKNESS***		Wght. Per 1000 Pcs.	Compressed in housing / Released in groove		Pr	Pg	
	Dh DEC	Dh FRAC	Dh mm	Dg	Tol.	W	Tol.	d	Df	Tol.	T		Tol.	L1			L2
HO-25	.250	1/4	6.4	.268	±.001	.020	+.002	.009	.280		.015		.08	.115	.133	426	190
HO-31	.312	5/16	7.9	.330	.0015*	.020	-.000	.009	.346		.015		.11	.173	.191	538	240
HO-37	.375	3/8	9.5	.397	±.002	.029		.011	.415		.025		.25	.204	.226	1066	350
HO-43	.438	7/16	11.1	.461	.002*	.029		.012	.482		.025		.37	.23	.254	1238	440
HO-45	.453	29/64	11.5	.477		.029		.012	.498		.025		.43	.25	.274	1299	460
HO-50	.500	1/2	12.7	.530		.039		.015	.548	+.010	.035		.70	.26	.290	2010	510
HO-51	.512	-	13.0	.542	±.002	.039		.015	.560	-.005	.035		.77	.27	.300	2060	520
HO-56	.562	9/16	14.3	.596	.004*	.039		.017	.620		.035		.86	.275	.305	2253	710
HO-62	.625	5/8	15.9	.665		.039		.020	.694		.035		1.0	.34	.380	2507	1050
HO-68	.688	11/16	17.5	.732		.039		.022	.763		.035		1.2	.40	.440	2741	1280
HO-75	.750	3/4	19.0	.796		.039	+.003	.023	.831		.035		1.3	.45	.490	3045	1460
HO-77	.777	-	19.7	.825		.046	-.000	.024	.859		.042		1.7	.475	.520	4618	1580
HO-81	.812	13/16	20.6	.862		.046		.025	.901		.042		1.9	.49	.540	4872	1710
HO-86	.866	-	22.0	.920	±.003	.046		.027	.961		.042		2.0	.54	.590	5177	1980
HO-87	.875	7/8	22.2	.931	.004*	.046		.028	.971		.042		2.1	.545	.600	5227	2080
HO-90	.901	-	22.9	.959		.046		.029	1.000	+.015	.042		2.2	.565	.620	5430	2200
HO-93	.938	15/16	23.8	1.000		.046		.031	1.041	-.010	.042	±.002	2.4	.61	.670	5684	2450
HO-100	1.000	1	25.4	1.066		.046		.033	1.111		.042		2.7	.665	.730	6039	2800
HO-102	1.023	-	26.0	1.091		.046		.034	1.136		.042		2.8	.69	.755	6141	3000
HO-106	1.062	1-1/16	27.0	1.130		.056		.034	1.180		.050		3.7	.685	.750	7562	3050
HO-112	1.125	1-1/8	28.6	1.197		.056		.036	1.249		.050		4.0	.745	.815	8019	3400
HO-118	1.181	-	30.0	1.255		.056		.037	1.319		.050		4.3	.79	.860	8526	3700
HO-118	1.188	1-3/16	30.2	1.262	±.004	.056		.037	1.319		.050		4.3	.80	.870	8526	3700
HO-125	1.250	1-1/4	31.7	1.330	.005*	.056		.040	1.388	+.025	.050		4.8	.875	.955	8932	4250
HO-125	1.259	-	32.0	1.339		.056		.040	1.388	-.020	.050		4.8	.885	.965	8932	4250
HO-131	1.312	1-5/16	33.3	1.396		.056		.042	1.456		.050		5.0	.93	1.01	9440	4700
HO-137	1.375	1-3/8	34.9	1.461		.056		.043	1.526		.050		5.1	.99	1.07	9846	5050
HO-137	1.378	-	35.0	1.464		.056	+.004	.043	1.526		.050		5.1	.99	1.07	9846	5050
HO-143	1.438	1-7/16	36.5	1.528		.056	-.000	.045	1.596		.050		5.8	1.06	1.15	10353	5500
HO-145	1.456	-	37.0	1.548		.056		.046	1.616		.050		6.4	1.08	1.17	10455	5700
HO-150	1.500	1-1/2	38.1	1.594		.056		.047	1.660		.050		6.5	1.12	1.21	10708	6000
HO-156	1.562	1-9/16	39.7	1.658		.068		.048	1.734		.062		8.9	1.14	1.23	13906	6350
HO-156	1.575	-	40.0	1.671		.068		.048	1.734		.062		8.9	1.15	1.24	13906	6350
HO-162	1.625	1-5/8	41.3	1.725	±.005	.068		.050	1.804	+.035	.062		10.0	1.15	1.25	14413	6900
HO-165	1.653	-	42.0	1.755	.005*	.068		.051	1.835	-.025	.062	±.003	10.4	1.17	1.27	14718	7200
HO-168	1.688	1-11/16	42.9	1.792		.068		.052	1.874		.062		10.8	1.23	1.33	15022	7450
HO-175	1.750	1-3/4	44.4	1.858		.068		.054	1.942		.062		10.3	1.26	1.36	15580	8050
HO-181	1.812	1-13/16	46.0	1.922		.068		.055	2.012		.062		11.5	1.34	1.38	16139	8450

\* F.I.M. (FULL INDICATOR MOVEMENT)- MAXIMUM ALLOWABLE DEVIATION OF CONCENTRICITY BETWEEN GROOVE & HOUSING.  
 i BASED ON HOUSINGS/SHAFTS MADE OF COLD ROLLED STEEL. FOR AN EXPLANATION OF FORMULAS USED TO DERIVE THRUST LOAD AND OTHER PERFORMANCE DATA CONTACT THE ROTOR CLIP ENGINEERING DEPARTMENT.  
 \*\*\*FOR PLATED RINGS ADD .002" TO THE LISTED MAXIMUM THICKNESS. MAXIMUM THICKNESS WILL BE A MINIMUM OF .0002" LESS THAN THE LISTED GROOVE WIDTH (W) MINIMUM.





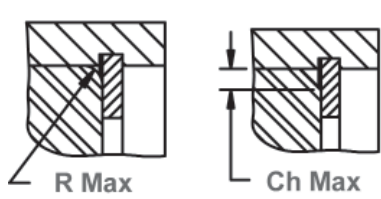

Allowable Corner Radius and Chamfer

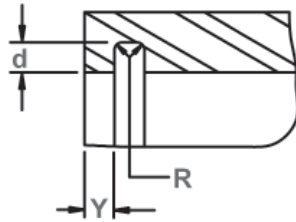

Exploded Groove Profile & Edge Margin (Y)  
Maximum bottom radii (R), .005 for ring sizes  
-25 thru -100; .010 for ring sizes 102 thru 1000

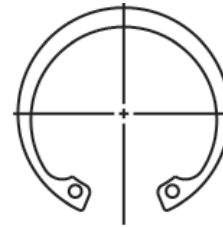

Alternate Lug Design  
For Larger Sizes  
(Manufacturer's Option)

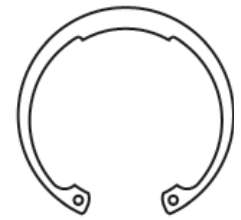

Alternate Design  
(Manufacturer's Option)

RING NO.	LUG HEIGHT		MAXIMUM SECTION		MINIMUM SECTION		HOLE DIAMETER		GAP WIDTH Ring in Groove	ALLOWABLE CORNER RADII & CHAMFERS			MAX. LOAD w/ R max or Ch max (lbs.)	EDGE MARGIN Y
	H	Tol.	S max	Tol.	S min	Tol.	R	Tol.		G Min	R max	Ch max		
HO-25	.065		.025	±.002	.015	±.002	.031		.047	.011	.0085	190	.027	
HO-31	.066		.033		.018		.031		.055	.016	.013	190	.027	
HO-37	.082	±.003	.040		.028		.041		.063	.023	.018	530	.033	
HO-43	.098		.049	±.003	.029	±.003	.041		.063	.027	.021	530	.036	
HO-45	.098		.050		.030		.047		.071	.027	.021	530	.036	
HO-50	.114		.053		.035		.047		.090	.027	.021	1100	.045	
HO-51	.114		.053		.035		.047		.092	.027	.021	1100	.045	
HO-56	.132		.053	±.004	.035	±.004	.047	+ .010	.095	.027	.021	1100	.051	
HO-62	.132		.060		.035		.062	- .002	.104	.027	.021	1100	.060	
HO-68	.132		.063		.036		.062		.118	.027	.021	1100	.066	
HO-75	.142		.070		.040		.062		.143	.032	.025	1100	.069	
HO-77	.146		.074		.044		.062		.145	.035	.028	1650	.072	
HO-81	.155		.077		.044		.062		.153	.035	.028	1650	.075	
HO-86	.155		.081		.045		.062		.172	.035	.028	1650	.081	
HO-87	.155		.084		.045		.062		.179	.035	.028	1650	.084	
HO-90	.155		.087	±.005	.047	±.005	.062		.188	.038	.030	1650	.087	
HO-93	.155		.091		.050		.062		.200	.038	.030	1650	.093	
HO-100	.155		.104		.052		.062		.212	.042	.034	1650	.099	
HO-102	.155	±.005	.106		.054		.062		.220	.042	.034	1650	.102	
HO-106	.180		.110		.055		.078		.213	.044	.035	2400	.102	
HO-112	.180		.116		.057		.078		.232	.047	.036	2400	.108	
HO-118	.180		.120		.058		.078		.226	.047	.036	2400	.111	
HO-118	.180		.120		.058		.078		.245	.047	.036	2400	.111	
HO-125	.180		.124		.062		.078		.265	.048	.038	2400	.120	
HO-125	.180		.124	±.006	.062	±.006	.078		.290	.048	.038	2400	.120	
HO-131	.180		.130		.062		.078		.284	.048	.038	2400	.126	
HO-137	.180		.130		.063		.078	+ .015	.297	.048	.038	2400	.129	
HO-137	.180		.130		.063		.078	- .002	.305	.048	.038	2400	.129	
HO-143	.180		.133		.065		.078		.313	.048	.038	2400	.135	
HO-145	.180		.133		.065		.078		.320	.048	.038	2400	.138	
HO-150	.180		.133		.066		.078		.340	.048	.038	2400	.141	
HO-156	.202		.157		.078		.078		.338	.064	.050	3900	.144	
HO-156	.202		.157		.078		.078		.374	.064	.050	3900	.144	
HO-162	.227		.164		.082		.078		.339	.064	.050	3900	.150	
HO-165	.230		.167	±.007	.083	±.007	.078		.348	.064	.050	3900	.153	
HO-168	.230		.170		.085		.078		.357	.064	.050	3900	.156	
HO-175	.230		.170		.083		.078		.372	.064	.050	3900	.162	
HO-181	.230		.170		.084		.093		.382	.064	.050	3900	.165	

FOR HARDNESS SPECIFICATIONS, SEE END OF THIS SECTION

Note: Specifications listed within the catalog tables reflect Rotor Clip's standard commercial production dimensions. Published retaining ring standards including Military (MIL-DTL-21248D) / ASME / NAS / ANSI may require parts with alternative geometry. Please contact Rotor Clip Technical Sales Department to clarify conformance to specific requirements. (Tech@rotorclip.com or +1-732-469-7333.)



# HO Housing Rings

## Axially Assembled, Internal

Once installed in the groove of a housing/bore, the portion of the ring protruding from the groove (also called a "shoulder") holds an assembly in place.

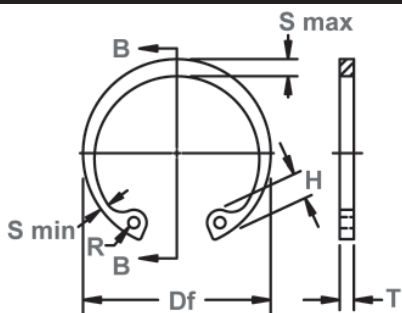

Free Diameter & Ring Measurements with Section B-B

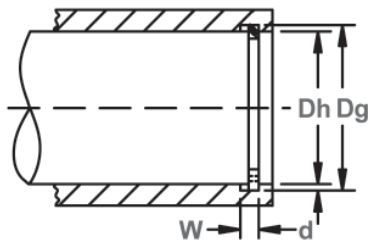

Housing Diameter & Groove Dimensions

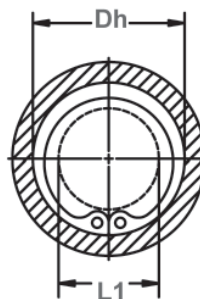

Clearance Diameter Compressed in Housing

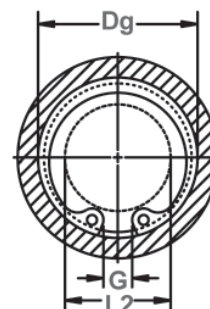

Clearance Diameter & Gap Width Released in Groove

RING NO.	HOUSING DIAMETER			GROOVE SIZE			RING SIZE & WEIGHT				CLEARANCE DIA.			i THRUST LD. (lbs.)			
				DIAMETER		WIDTH	DEPTH	Free Diameter		Thickness***		Wght. Per 1000 Pcs.	Compressed in housing	Re-leased in groove	Sqr. corner abutment		
	Dh DEC	Dh FRAC	Dh mm	Dg	Tol.	W	Tol.	d	Df	Tol.	T				Tol.	L1	L2
HO-185	1.850	-	47.0	1.962		.068		.056	2.054		.062		12.8	1.35	1.46	16443	8750
HO-187	1.875	1-7/8	47.6	1.989	±.005	.068	+.004	.057	2.072	+.035	.062		12.8	1.37	1.48	16697	9050
HO-193	1.938	1-15/16	49.2	2.056	.005*	.068	-.000	.059	2.141	-.025	.062		13.3	1.46	1.58	17255	9700
HO-200	2.000	2	50.8	2.122		.068		.061	2.210		.062		14.0	1.52	1.64	17763	10300
HO-206	2.047	-	52.0	2.171		.086		.062	2.280		.078		18.0	1.52	1.64	23091	10850
HO-206	2.062	2-1/16	52.4	2.186		.086		.062	2.280		.078		18.0	1.54	1.66	23091	10850
HO-212	2.125	2-1/8	54.0	2.251		.086		.063	2.350		.078		19.4	1.58	1.70	23751	11350
HO-218	2.165	-	55.0	2.295		.086		.065	2.415		.078		19.6	1.63	1.75	24461	12050
HO-218	2.188	2-3/16	55.6	2.318		.086		.065	2.415		.078		19.6	1.66	1.79	24461	12050
HO-225	2.250	2-1/4	57.1	2.382		.086		.066	2.490		.078		21.8	1.67	1.80	25223	12600
HO-231	2.312	2-5/16	58.7	2.450		.086		.069	2.560		.078		22.6	1.73	1.93	25832	13550
HO-237	2.375	2-3/8	60.3	2.517		.086		.071	2.630		.078		23.2	1.79	1.86	26542	14300
HO-244	2.440	2-7/16	62.0	2.584		.086		.072	2.702	+.040	.078		25.4	1.86	2.00	27304	14900
HO-250	2.500	2-1/2	63.5	2.648		.086		.074	2.775	-.030	.078		25.5	1.91	2.05	28014	15650
HO-250	2.531	2-17/32	64.3	2.681		.086		.075	2.775		.078		25.5	1.94	2.09	28014	15650
HO-256	2.562	2-9/16	65.1	2.714		.103		.076	2.844		.093		34.0	1.93	2.08	34206	16500
HO-262	2.625	2-5/8	66.7	2.781	±.006	.103	+.005	.078	2.910		.093	±.003	34.5	2.02	2.17	35068	17350
HO-268	2.677	-	68.0	2.837	.006*	.103	-.000	.080	2.980		.093		35.0	2.05	2.21	35931	18250
HO-268	2.688	2-11/16	68.3	2.848		.103		.080	2.980		.093		35.0	2.06	2.22	35931	18250
HO-275	2.750	2-3/4	69.8	2.914		.103		.082	3.050		.093		35.5	2.12	2.28	36642	19200
HO-281	2.812	2-13/16	71.4	2.980		.103		.084	3.121		.093		36.0	2.18	2.34	37504	20050
HO-281	2.835	-	72.0	3.006		.103		.085	3.121		.093		36.0	2.21	2.38	37504	20050
HO-287	2.875	2-7/8	73.0	3.051		.103		.088	3.191		.093		41.0	2.24	2.41	38367	21500
HO-300	2.953	-	75.0	3.135		.103		.091	3.325		.093		42.5	2.32	2.50	40093	23150
HO-300	3.000	3	76.2	3.182		.103		.091	3.325		.093		42.5	2.37	2.55	40093	23150
HO-306	3.062	3-1/16	77.8	3.248		.120		.093	3.418		.109		53.0	2.41	2.59	47807	24100
HO-312	3.125	3-1/8	79.4	3.315		.120		.095	3.488		.109		56.0	2.47	2.66	48822	25200
HO-315	3.149	-	80.0	3.341		.120		.096	3.523		.109		57.0	2.49	2.68	49329	25700
HO-315	3.156	3-5/32	80.2	3.348		.120		.096	3.523		.109		57.0	2.50	2.69	49329	25700
HO-325	3.250	3-1/4	82.5	3.446		.120		.098	3.623	±.055	.109		60.0	2.54	2.73	50750	27000
HO-334	3.346	3-11/32	85.0	3.546		.120		.100	3.734		.109		65.0	2.63	2.83	52374	28300
HO-347	3.469	3-15/32	88.1	3.675		.120		.103	3.857		.109		69.0	2.76	2.96	54201	30200
HO-350	3.500	3-1/2	88.9	3.710		.120		.105	3.890		.109		71.0	2.79	3.00	54709	31200
HO-354	3.543	-	90.0	3.755		.120		.106	3.936		.109		72.0	2.83	3.04	55419	31800
HO-354	3.562	3-9/16	90.5	3.776		.120		.107	3.936		.109		72.0	2.85	3.06	55419	31800
HO-362	3.625	3-5/8	92.1	3.841		.120		.108	4.024		.109		73.0	2.91	3.12	56739	33200
HO-375	3.740	-	95.0	3.964		.120		.112	4.157	±.065	.109		78.0	3.02	3.24	58566	35600
HO-375	3.750	3-3/4	95.2	3.974		.120		.112	4.157		.109		78.0	3.03	3.25	58566	35600

\* F.I.M. (FULL INDICATOR MOVEMENT)- MAXIMUM ALLOWABLE DEVIATION OF CONCENTRICITY BETWEEN GROOVE & HOUSING.

i BASED ON HOUSINGS/SHAFTS MADE OF COLD ROLLED STEEL. FOR AN EXPLANATION OF FORMULAS USED TO DERIVE THRUST LOAD AND OTHER PERFORMANCE DATA CONTACT THE ROTOR CLIP ENGINEERING DEPARTMENT.

\*\*\*FOR PLATED RINGS ADD .002" TO THE LISTED MAXIMUM THICKNESS. MAXIMUM THICKNESS WILL BE A MINIMUM OF .0002" LESS THAN THE LISTED GROOVE WIDTH (W) MINIMUM.



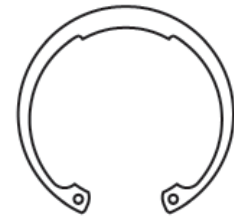
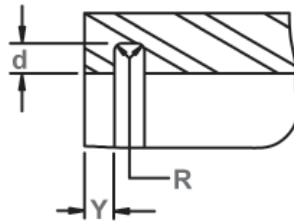
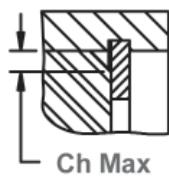
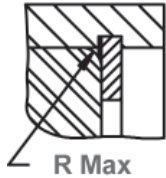

Allowable Corner Radius and Chamfer

Exploded Groove Profile & Edge Margin (Y)  
Maximum bottom radii (R), .005 for ring sizes  
-25 thru -100; .010 for ring sizes 102 thru 1000

Alternate Lug Design  
For Larger Sizes  
(Manufacturer's Option)

Alternate Design  
(Manufacturer's Option)

RING NO.	LUG HEIGHT		MAXIMUM SECTION		MINIMUM SECTION		HOLE DIAMETER		GAP WIDTH Ring in Groove	ALLOWABLE CORNER RADII & CHAMFERS			MAX. LOAD w/ R max or Ch max (lbs.)	EDGE MARGIN
	H	Tol.	S max	Tol.	S min	Tol.	R	Tol.		G Min	R max	Ch max		
HO-185	.234		.170		.085		.093		.360	.064	.050	3900	.168	
HO-187	.234		.170		.085		.093		.430	.064	.050	3900	.171	
HO-193	.230		.170		.085		.093		.438	.064	.050	3900	.177	
HO-200	.230		.170		.085		.093		.453	.064	.050	3900	.183	
HO-206	.250		.186		.091		.093		.428	.078	.061	6200	.186	
HO-206	.250		.186		.091		.093		.468	.078	.062	6200	.186	
HO-212	.250		.195		.096		.093		.460	.078	.062	6200	.189	
HO-218	.250		.199		.098		.093		.439	.078	.062	6200	.195	
HO-218	.250		.199		.098		.093		.489	.078	.062	6200	.195	
HO-225	.280		.203		.099		.093		.478	.078	.062	6200	.198	
HO-231	.280	±.005	.206	±.007	.100	±.007	.093		.486	.078	.062	6200	.207	
HO-237	.280		.207		.102		.093		.504	.078	.062	6200	.213	
HO-244	.280		.209		.103		.110		.518	.078	.062	6200	.216	
HO-250	.280		.210		.103		.110		.532	.078	.062	6200	.222	
HO-250	.280		.210		.103		.110	+ .015	.597	.078	.062	6200	.225	
HO-256	.300		.222		.109		.110	- .002	.540	.088	.070	9000	.228	
HO-262	.300		.226		.111		.110		.558	.088	.070	9000	.234	
HO-268	.300		.230		.113		.110		.539	.090	.072	9000	.240	
HO-268	.300		.230		.113		.110		.568	.090	.072	9000	.240	
HO-275	.300		.234		.115		.110		.590	.092	.074	9000	.246	
HO-281	.300		.230		.115		.110		.615	.088	.070	9000	.252	
HO-281	.300		.230		.115		.110		.676	.088	.070	9000	.255	
HO-287	.300		.240		.120		.110		.626	.092	.074	9000	.264	
HO-300	.300		.250		.122		.110		.619	.092	.074	9000	.273	
HO-300	.300		.250		.122		.110		.738	.092	.074	9000	.273	
HO-306	.310		.254		.126		.125		.651	.097	.078	12000	.279	
HO-312	.310		.259		.129		.125		.655	.099	.079	12000	.285	
HO-315	.310		.262		.129		.125		.650	.100	.080	12000	.288	
HO-315	.310		.262		.129		.125		.669	.100	.080	12000	.288	
HO-325	.342		.269		.135		.125		.698	.104	.083	12000	.294	
HO-334	.342	±.008	.276	±.008	.140	±.008	.125		.705	.108	.086	12000	.300	
HO-347	.342		.286		.144		.125		.763	.108	.086	12000	.309	
HO-350	.342		.289		.142		.125		.774	.110	.088	12000	.315	
HO-354	.342		.292		.142		.125		.788	.110	.088	12000	.318	
HO-354	.342		.292		.142		.125		.842	.110	.088	12000	.321	
HO-362	.342		.299		.150		.125		.833	.116	.093	12000	.324	
HO-375	.342		.309		.155		.125		.844	.120	.096	12000	.336	
HO-375	.342		.309		.155		.125		.871	.120	.096	12000	.336	

**FOR HARDNESS SPECIFICATIONS, SEE END OF THIS SECTION**

Note: Specifications listed within the catalog tables reflect Rotor Clip's standard commercial production dimensions. Published retaining ring standards including Military (MIL-DTL-21248D) / ASME / NAS / ANSI may require parts with alternative geometry. Please contact Rotor Clip Technical Sales Department to clarify conformance to specific requirements. (Tech@rotorclip.com or +1-732-469-7333.)





# HO Housing Rings

## Axially Assembled, Internal

Once installed in the groove of a housing/bore, the portion of the ring protruding from the groove (also called a "shoulder") holds an assembly in place.

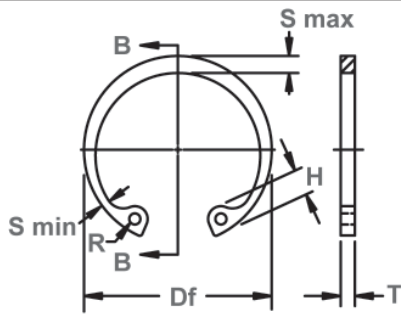

Free Diameter & Ring Measurements with Section B-B

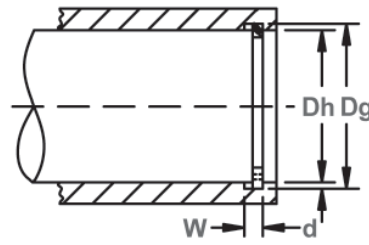

Housing Diameter & Groove Dimensions

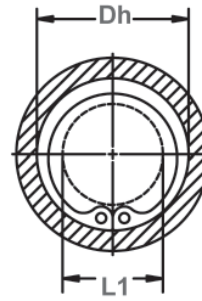

Clearance Diameter Compressed in Housing

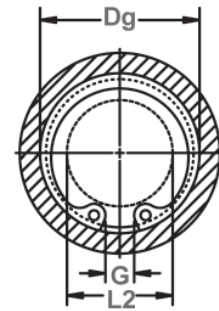

Clearance Diameter & Gap Width Released in Groove

RING NO.	HOUSING DIAMETER			GROOVE SIZE			RING SIZE & WEIGHT				CLEAR. DIA.		† THRUST LD. (lbs.)				
				DIAMETER		WIDTH	DEPTH	Free Diameter		Thickness***	Weight. Per 1000 Pcs.	Compressed in housing	Released in groove	Ring Safety Factor of 4	Groove Safety Factor of 2		
	Dh DEC	Dh FRAC	Dh mm	Dg	Tol.	W	Tol.	d	Df	Tol.	T	Tol.	lbs.	L1	L2	Pr	Pg
HO-387	3.875	3-7/8	98.4	4.107		.120		.116	4.291		.109		87.0	3.11	3.34	60494	38000
HO-393	3.938	3-15/16	100.0	4.174		.120		.118	4.358		.109		88.0	3.17	3.40	61611	39300
HO-400	4.000	4	101.6	4.240		.120		.120	4.424		.109		93.0	3.23	3.47	62626	40700
HO-412	4.125	4-1/8	104.8	4.365		.120		.120	4.558		.109		97.0	3.36	3.60	64554	42000
HO-425	4.250	4-1/4	108.0	4.490	±.006	.120	+.005	.120	4.691		.109	±.003	101.0	3.48	3.72	66483	43200
HO-433	4.331	-	110.0	4.571	.006*	.120	-.000	.120	4.756		.109		105.0	3.50	3.74	67599	44500
HO-450	4.500	4-1/2	114.3	4.740		.120		.120	4.940		.109		111.0	3.66	3.90	70340	45800
HO-462	4.625	4-5/8	117.5	4.865		.120		.120	5.076	±.065	.109		117.0	3.79	4.03	72370	47000
HO-475	4.724	-	120.0	4.969		.120		.122	5.213		.109		124.0	3.88	4.12	74298	49000
HO-475	4.750	4-3/4	120.6	4.995		.120		.122	5.213		.109		124.0	3.90	4.14	74298	49000
HO-500	5.000	5	127.0	5.260		.120		.130	5.485		.109		136.0	4.08	4.34	78155	55000
HO-525	5.250	5-1/4	133.3	5.520		.139		.135	5.770		.125		174.0	4.35	4.62	94091	60000
HO-537	5.375	5-3/8	136.5	5.650	±.007	.139	+.006	.135	5.910		.125	±.004	179.0	4.45	4.72	96324	61500
HO-550	5.500	5-1/2	139.7	5.770	.006*	.139	-.000	.135	6.066		.125		183.0	4.57	4.84	98658	63300
HO-575	5.750	5-3/4	146.0	6.020		.139		.135	6.336		.125		192.0	4.82	5.09	103124	65900
HO-600	6.000	6	152.4	6.270		.139		.135	6.620		.125		202.1	5.07	5.34	107489	68600
HO-625	6.250	6-1/4	158.7	6.530		.174		.140	6.895		.156		266.0	5.24	5.52	139766	74100
HO-650	6.500	6-1/2	165.1	6.790		.174		.145	7.170		.156		281.0	5.49	5.78	145450	79900
HO-662	6.625	6-5/8	168.3	6.925		.174		.150	7.308	±.080	.156		305.0	5.60	5.90	148190	84200
HO-675	6.750	6-3/4	171.4	7.055		.174		.152	7.445		.156		325.0	5.68	5.98	151032	87000
HO-700	7.000	7	177.8	7.315		.174		.157	7.720		.156		344.0	5.91	6.22	156615	93100
HO-725	7.250	7-1/4	184.1	7.575		.209		.162	7.995		.187		428.0	6.11	6.43	194373	99600
HO-750	7.500	7-1/2	190.5	7.840	±.008	.209	+.008	.170	8.270		.187		485.0	6.36	6.70	201173	108100
HO-775	7.750	7-3/4	196.8	8.100	.006*	.209	-.000	.175	8.545		.187		520.0	6.58	6.93	207872	115000
HO-800	8.000	8	203.2	8.360		.209		.180	8.820		.187	±.005	555.0	6.83	7.19	214571	122000
HO-825	8.250	8-1/4	209.5	8.620		.209		.185	9.095		.187		603.0	7.04	7.41	221270	129300
HO-850	8.500	8-1/2	215.9	8.880		.209		.190	9.285	±.090	.187		634.0	7.29	7.67	227969	136900
HO-875	8.750	8-3/4	222.2	9.145		.209		.197	9.558		.187		653.0	7.38	7.77	233856	145500
HO-900	9.000	9	228.6	9.405		.209		.202	9.830		.187		732.0	7.63	8.03	241367	154100
HO-925	9.250	9-1/4	235.0	9.668		.209		.209	10.102		.187		767.0	7.88	8.30	248066	163600
HO-950	9.500	9-1/2	241.3	9.930		.209		.215	10.375		.187		803.0	7.98	8.41	254765	173100
HO-975	9.750	9-3/4	247.7	10.190		.209		.220	10.648		.187		833.0	8.23	8.67	261464	181900
HO-1000	10.000	10	254.0	10.450		.209		.225	10.920		.187		863.0	8.48	8.93	268163	190700

\* F.I.M. (FULL INDICATOR MOVEMENT)- MAXIMUM ALLOWABLE DEVIATION OF CONCENTRICITY BETWEEN GROOVE & HOUSING.

† BASED ON HOUSINGS/SHAFTS MADE OF COLD ROLLED STEEL. FOR AN EXPLANATION OF FORMULAS USED TO DERIVE THRUST LOAD AND OTHER PERFORMANCE DATA CONTACT THE ROTOR CLIP ENGINEERING DEPARTMENT.

\*\*\*FOR PLATED RINGS ADD .002" TO THE LISTED MAXIMUM THICKNESS. MAXIMUM THICKNESS WILL BE A MINIMUM OF .0002" LESS THAN THE LISTED GROOVE WIDTH (W) MINIMUM.

Note: Specifications listed within the catalog tables reflect Rotor Clip's standard commercial production dimensions. Published retaining ring standards including Military (MIL-DTL-21248D) / ASME / NAS / ANSI may require parts with alternative geometry. Please contact Rotor Clip Technical Sales Department to clarify conformance to specific requirements. (Tech@rotorclip.com or +1-732-469-7333.)

HARDNESS RANGES: STAINLESS STEEL RINGS (PH 15-7MO)

RING TYPE	SIZE RANGE	SCALE	ROCKWELL HARDNESS
HO	25&31	15N	82.5-86
	37-102	30N	63-69.5
	106+	C	44-51



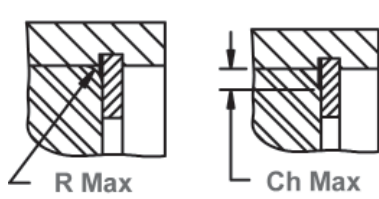

Allowable Corner Radius and Chamfer

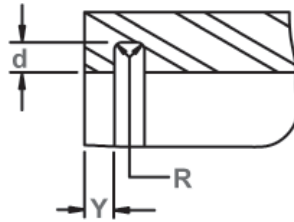

Exploded Groove Profile & Edge Margin (Y)  
Maximum bottom radii (R), .005 for ring sizes  
-25 thru -100; .010 for ring sizes 102 thru 1000

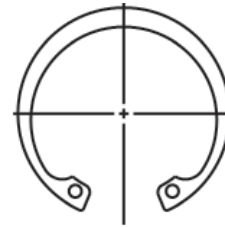

Alternate Lug Design  
For Larger Sizes  
(Manufacturer's Option)



Alternate Design  
(Manufacturer's Option)

RING NO.	LUG HEIGHT		MAXIMUM SECTION		MINIMUM SECTION		HOLE DIAMETER		GAP WIDTH Ring in Groove		ALLOWABLE CORNER RADII & CHAMFERS			MAX. LOAD w/R max or Ch max. (lbs.)		EDGE MARGIN	
	H	Tol.	S max	Tol.	S min	Tol.	R	Tol.	G Min	R max	Ch max	P'r	Y				
HO-387	.370		.319		.160		.125		.891	.123	.098	12000	.348				
HO-393	.370		.324	±.008	.161	±.008	.125	+ .015	.905	.124	.099	12000	.354				
HO-400	.370		.330		.166		.125	-.002	.918	.128	.102	12000	.360				
HO-412	.370		.330		.171		.125		.940	.130	.104	12000	.360				
HO-425	.370		.335		.180		.125		.960	.138	.110	12000	.360				
HO-433	.405	±.008	.343		.180		.156		1.000	.142	.114	12000	.360				
HO-450	.405		.351		.181		.156		.980	.146	.117	12000	.360				
HO-462	.405		.405		.183		.156		1.000	.151	.121	12000	.360				
HO-475	.405		.370		.183		.156		.960	.154	.123	12000	.366				
HO-475	.405		.370	±.009	.183	±.009	.156		1.030	.154	.123	12000	.366				
HO-500	.435		.390		.186		.156		.970	.158	.126	12000	.390				
HO-525	.435		.435		.198		.156		1.10	.168	.134	15000	.405				
HO-537	.455		.408		.198		.156		1.12	.168	.134	15000	.405				
HO-550	.435		.435		.198		.156		1.09	.168	.134	15000	.405				
HO-575	.435		.435		.198		.156		1.11	.168	.134	15000	.405				
HO-600	.435		.435		.198		.156		1.13	.168	.134	15000	.405				
HO-625	.485		.485		.211		.187		1.16	.177	.142	23000	.420				
HO-650	.485		.438		.219		.187		1.25	.181	.145	23000	.435				
HO-662	.485		.485		.221		.187	+ .020	1.28	.183	.146	23000	.450				
HO-675	.530		.456		.224		.187	-.005	1.21	.188	.150	23000	.456				
HO-700	.515		.515		.232		.187		1.26	.196	.157	23000	.471				
HO-725	.545	±.010	.545		.238		.187		1.32	.202	.162	34000	.486				
HO-750	.560		.507		.247		.187		1.39	.208	.166	34000	.510				
HO-775	.560		.523		.255		.187		1.44	.214	.171	34000	.525				
HO-800	.560		.560		.262		.187		1.50	.220	.176	34000	.540				
HO-825	.600		.558	±.010	.270	±.010	.187		1.53	.229	.183	34000	.555				
HO-850	.660		.573		.277		.187		1.71	.235	.188	34000	.570				
HO-875	.660		.660		.286		.187		1.77	.241	.193	34000	.591				
HO-900	.660		.609		.294		.187		1.83	.249	.199	34000	.606				
HO-925	.660		.625		.299		.187		1.87	.253	.202	34000	.627				
HO-950	.735		.642		.304		.187		1.91	.258	.206	34000	.645				
HO-975	.735		.658		.309		.187		2.00	.263	.210	34000	.660				
HO-1000	.735		.675		.315		.187		2.01	.270	.216	34000	.675				

LARGER SIZES MAY BE AVAILABLE UPON REQUEST.

HARDNESS RANGES: CARBON STEEL RINGS (SAE 1060-1090)

RING TYPE	SIZE RANGE	SCALE	ROCKWELL HARDNESS
HO	25&31	15N	86-88
	37-51	30N	69.5-73
	56-77	30N	67.5-72
	81-102	30N	66-71
	106-347	C	47-52
	350-700	C	44-51
	725-1000	C	40-47

HARDNESS RANGES: BERYLLIUM COPPER RINGS

RING TYPE	SIZE RANGE	SCALE	ROCKWELL HARDNESS
HO	25&31	15N	77-82
	37-102	30N	54-62
	106+	C	34-43





# SH Shaft Rings

**Axially Assembled, External**  
 Once installed in the groove of a shaft, the portion of the ring protruding from the groove (also called a "shoulder") holds an assembly in place.

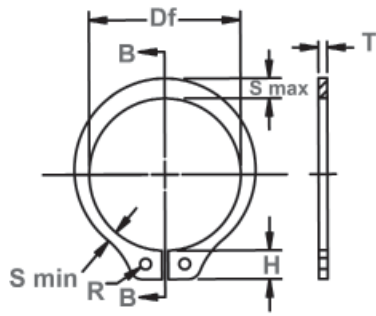

Free Diameter & Ring Measurements with Section B-B

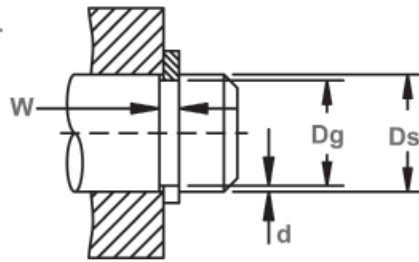

Shaft Diameter & Groove Dimensions

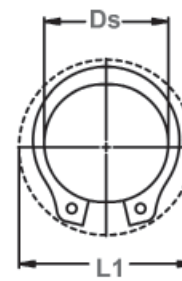

Clearance Diameter Expanded Over Shaft



Clearance Diameter & Gaging Diameter Released in Groove.

RING NO.	SHAFT DIAMETER			GROOVE SIZE			RING SIZE & WEIGHT				CLEARANCE DIA.			THRUST LD. (lbs.)			
				DIAMETER		WIDTH		DEPTH	FREE DIAMETER		THICKNESS***		Weight Per 1000 pcs.	Expanded over Shaft	Re-leased in Groove	Sqr. Corner Abutment	
	Ds DEC	Ds FRAC	Ds mm	Dg	Tol.	W	Tol.	d	Df	Tol.	T	Tol.				lbs.	L1
**SH-12	.125	1/8	3.2	.117		.012		.004	.112		.010	±.001	.018	.222	.214	112	35
**SH-15	.156	5/32	4.0	.146		.012		.005	.142		.010		.037	.27	.260	132	55
**SH-18	.188	3/16	4.8	.175	±.0015	.018	+.002	.006	.168	+.002	.015		.059	.298	.286	244	80
**SH-19	.197	-	5.0	.185	.0015*	.018	-.000	.006	.179	-.004	.015		.063	.319	.307	254	85
**SH-21	.219	7/32	5.6	.205		.018		.007	.196		.015		.074	.338	.324	284	110
**SH-23	.236	15/64	6.0	.222		.018		.007	.215		.015		.086	.355	.341	315	120
SH-25	.250	1/4	6.4	.230		.029		.010	.225		.025		.21	.45	.43	599	175
SH-27	.276	-	7.0	.255		.029		.010	.250		.025		.23	.48	.46	660	195
SH-28	.281	9/32	7.1	.261		.029		.010	.256		.025		.24	.49	.47	670	200
SH-31	.312	5/16	7.9	.290		.029		.011	.281		.025		.27	.54	.52	751	240
SH-34	.344	11/32	8.7	.321	±.002	.029		.011	.309		.025		.31	.57	.55	812	265
SH-35	.354	-	9.0	.330	.002*	.029		.012	.320	+.002	.025		.35	.59	.57	832	300
SH-37	.375	3/8	9.5	.352		.029		.012	.338	-.005	.025		.39	.61	.59	883	320
SH-39	.394	-	10.0	.369		.029		.012	.354		.025		.42	.62	.60	954	335
SH-40	.406	13/32	10.3	.382		.029		.012	.366		.025		.43	.63	.61	964	350
SH-43	.438	7/16	11.1	.412		.029		.013	.395		.025		.50	.66	.64	1035	400
SH-46SP1	.461	-	11.7	.435		.029		.013	.420		.025		.51	.68	.66	1110	460
SH-46	.469	15/32	11.9	.443		.029		.013	.428		.025	±.002	.54	.68	.66	1117	450
SH-50	.500	1/2	12.7	.468	±.002	.039	+.003	.016	.461		.035		.91	.77	.74	1675	550
SH-55	.551	-	14.0	.519	.004*	.039	-.000	.016	.509		.035		.90	.81	.78	1800	600
SH-56	.562	9/16	14.3	.530		.039		.016	.521		.035		1.1	.82	.79	1878	650
SH-59	.594	19/32	15.1	.559		.039		.017	.550		.035		1.2	.86	.83	1979	750
SH-62	.625	5/8	15.9	.588		.039		.018	.579		.035		1.3	.90	.87	2091	800
SH-66	.669	-	17.0	.629		.039		.020	.621	+.005	.035		1.4	.93	.89	2233	950
SH-66	.672	43/64	17.1	.631		.039		.020	.621	-.010	.035		1.4	.93	.89	2233	950
SH-68	.688	11/16	17.5	.646		.046		.021	.635		.042		1.8	1.01	.97	3451	1000
SH-75	.750	3/4	19.0	.704	±.003	.046		.023	.693		.042		2.1	1.09	1.05	3756	1200
SH-78	.781	25/32	19.8	.733	.004*	.046		.024	.722		.042		2.2	1.12	1.08	3959	1300
SH-81	.812	13/16	20.6	.762		.046		.025	.751		.042		2.5	1.15	1.10	4060	1450
SH-84	.844	-	21.4	.791		.046		.026	.780		.042		2.7	1.18	1.13	4200	1500
SH-87	.875	7/8	22.2	.821		.046		.027	.810		.042		2.8	1.21	1.16	4365	1650
SH-93	.938	15/16	23.8	.882		.046		.028	.867		.042		3.1	1.34	1.29	4720	1850
SH-98	.984	63/64	25.0	.926		.046		.029	.910		.042		3.5	1.39	1.34	4923	2000
SH-100	1.000	1	25.4	.940		.046		.030	.925		.042		3.6	1.41	1.35	5024	2100
SH-102	1.023	-	26.0	.961		.046		.031	.946		.042		3.9	1.43	1.37	5126	2250
SH-106	1.062	1-1/16	27.0	.998	±.004	.056	+.004	.032	.982	+.010	.050		4.8	1.50	1.44	6293	2400
SH-112	1.125	1-1/8	28.6	1.059	.005*	.056	-.000	.033	1.041	-.015	.050		5.1	1.55	1.49	6699	2600

\*\*SIZES -12 THRU -23 STANDARD MATERIAL- CARBON STEEL; OPTIONAL MATERIAL- BERYLLIUM COPPER.

\* F.I.M. (FULL INDICATOR MOVEMENT)- MAXIMUM ALLOWABLE DEVIATION OF CONCENTRICITY BETWEEN GROOVE & SHAFT.

† BASED ON HOUSINGS/SHAFTS MADE OF COLD ROLLED STEEL. FOR AN EXPLANATION OF FORMULAS USED TO DERIVE THRUST LOAD AND OTHER PERFORMANCE DATA CONTACT THE ROTOR CLIP ENGINEERING DEPARTMENT.

\*\*\*FOR PLATED RINGS ADD .002" TO THE LISTED MAXIMUM THICKNESS. MAXIMUM THICKNESS WILL BE A MINIMUM OF .0002" LESS THAN THE LISTED GROOVE WIDTH (W) MINIMUM.



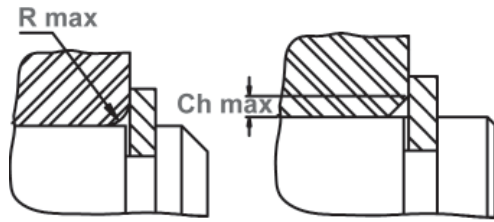

Maximum Corner Radius & Chamfer

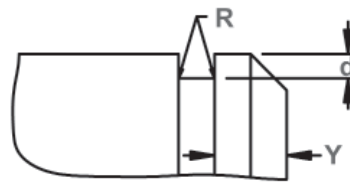

Exploded Groove Profile & Edge Margin (Y)  
Maximum bottom radii (R), sharp corners for ring sizes -12 thru -23; .003 for ring sizes -25 thru -35; .005 for sizes -37 thru -100; .010 for ring sizes -102 thru -1000



Lug Design For Sizes SH-12 thru SH-23



Alternate Design Manufacturer's Option

RING NO.	LUG HEIGHT		MAXIMUM SECTION		MINIMUM SECTION		HOLE DIAMETER		GAGING DIA.	ALLOWABLE CORNER RADII & CHAMFERS			MAX. LOAD w/ R max or Ch max (lbs.)	EDGE MARGIN	R.P.M. LIMITS Standard Material
	H	Tol.	S max	Tol.	S min	Tol.	R	Tol.	Gd Max	R max	Ch max	P'r	Y	RPM	
**SH-12	.046	±.002	.018	±.0015	.011	±.0015	.026		.148	.010	.006	45	.012	80000	
**SH-15	.054		.026		.016		.026		.189	.015	.009	45	.015	80000	
**SH-18	.050		.025		.016		.025		.218	.014	.0085	105	.018	80000	
**SH-19	.056		.026	±.002	.016	±.002	.026		.229	.0145	.009	105	.018	80000	
**SH-21	.056		.028		.017		.026		.252	.015	.009	105	.021	80000	
**SH-23	.056	.030		.019		.026	.272	.0165	.010	105	.021	80000			
SH-25	.080	±.003	.035	±.003	.025	±.003	.041	+.010 -.002	.290	.018	.011	470	.030	80000	
SH-27	.081		.035		.024		.041		.315	.0175	.0105	470	.031	76000	
SH-28	.080		.038		.025		.041		.326	.020	.012	470	.030	74000	
SH-31	.087		.040		.026		.041		.357	.020	.012	470	.033	70000	
SH-34	.087		.042		.0265		.041		.390	.021	.0125	470	.033	64000	
SH-35	.087		.046		.029		.041		.405	.023	.014	470	.036	62000	
SH-37	.088		.050		.0305		.041		.433	.026	.0155	470	.036	60000	
SH-39	.087		.052		.031		.041		.452	.027	.016	470	.037	56500	
SH-40	.087		.054		.033		.041		.468	.0285	.017	470	.036	55000	
SH-43	.088		.055		.033		.041		.501	.029	.0175	470	.039	50000	
SH-46SP1	.092	.064	.038	.041	.540	.015	.017	470	.039	42000					
SH-46	.088	.060	.035	.041	.540	.031	.018	470	.039	42000					
SH-50	.108	.065	.040	.047	.574	.034	.020	910	.048	40000					
SH-55	.108	.053	.036	.047	.611	.027	.0165	910	.048	36000					
SH-56	.108	.072	.041	.047	.644	.038	.023	910	.048	35000					
SH-59	.109	.076	.043	.047	.680	.0395	.0235	910	.052	32000					
SH-62	.110	.080	.045	.047	.715	.0415	.025	910	.055	30000					
SH-66	.110	.082	.043	.047	.756	.040	.024	910	.060	29000					
SH-66	.110	.082	.043	.047	.758	.040	.024	910	.060	29000					
SH-68	.136	.084	.048	.052	.779	.042	.025	1340	.063	28000					
SH-75	.136	.092	.051	.052	.850	.046	.0275	1340	.069	26500					
SH-78	.136	.094	.052	.052	.883	.047	.028	1340	.072	25500					
SH-81	.136	.096	.054	.052	.914	.047	.028	1340	.075	24500					
SH-84	.137	.100	.057	.052	.950	.047	.028	1340	.078	24000					
SH-87	.137	.104	.057	.052	.987	.051	.0305	1340	.081	23000					
SH-93	.166	.110	.063	.078	1.054	.055	.033	1340	.084	21500					
SH-98	.167	.114	.064	.078	1.106	.056	.0335	1340	.087	20500					
SH-100	.167	.116	.065	.078	1.122	.057	.034	1340	.090	20000					
SH-102	.168	.118	.066	.078	1.147	.058	.035	1340	.093	19500					
SH-106	.181	.122	.069	.078	1.192	.060	.036	1950	.096	19000					
SH-112	.182	.128	.071	.078	1.261	.063	.038	1950	.099	18800					

FOR HARDNESS SPECIFICATIONS, SEE END OF THIS SECTION.

Note: Specifications listed within the catalog tables reflect Rotor Clip's standard commercial production dimensions. Published retaining ring standards including Military (MIL-DTL-21248D) / ASME / NAS / ANSI may require parts with alternative geometry. Please contact Rotor Clip Technical Sales Department to clarify conformance to specific requirements. (Tech@rotorclip.com or +1-732-469-7333.)



# SH Shaft Rings

**Axially Assembled, External**  
 Once installed in the groove of a shaft, the portion of the ring protruding from the groove (also called a "shoulder") holds an assembly in place.

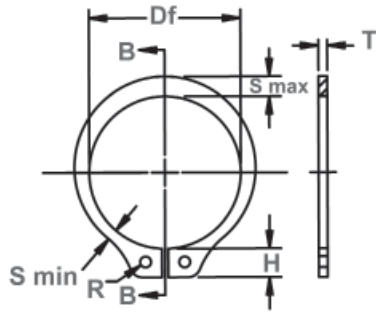

Free Diameter & Ring Measurements with Section B-B

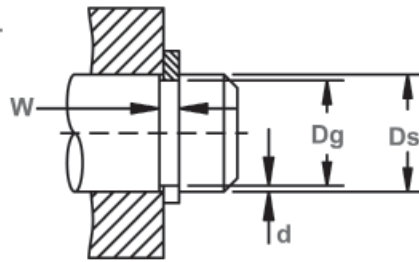

Shaft Diameter & Groove Dimensions

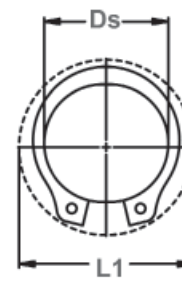

Clearance Diameter Expanded Over Shaft



Clearance Diameter & Gaging Diameter Released in Groove.

RING NO.	SHAFT DIAMETER			GROOVE SIZE			RING SIZE & WEIGHT				CLEARANCE DIA.			THRUST LD.(lbs.)			
				DIAMETER		WIDTH	DEPTH	FREE DIAMETER		THICKNESS***		Weight Per 1000 pcs.	Expanded over Shaft	Re-leased in Groove	Sqr. Corner Abutment		
	Ds DEC	Ds FRAC	Ds mm	Dg	Tol.	W	Tol.	d	Df	Tol.	T				Tol.	lbs.	L1
SH-118	1.188	1-3/16	30.2	1.118		.056		.035	1.098		.050		5.6	1.61	1.54	7105	2950
SH-125	1.250	1-1/4	31.7	1.176		.056		.037	1.156		.050		5.9	1.69	1.62	7460	3250
SH-131	1.312	1-5/16	33.3	1.232	±.004	.056		.040	1.214	+.010	.050	±.002	6.8	1.75	1.67	7866	3700
SH-137	1.375	1-3/8	34.9	1.291	.005*	.056		.042	1.272	-.015	.050		7.2	1.80	1.72	8222	4100
SH-143	1.438	1-7/16	36.5	1.350		.056		.044	1.333		.050		8.1	1.87	1.79	8628	4500
SH-150	1.500	1-1/2	38.1	1.406		.056		.047	1.387		.050		9.0	1.99	1.90	8932	5000
SH-156	1.562	1-9/16	39.7	1.468		.068		.047	1.446		.062		12.4	2.10	2.01	11571	5200
SH-162	1.625	1-5/8	41.3	1.529		.068	+.004	.048	1.503		.062		13.2	2.17	2.08	12028	5500
SH-168	1.688	1-11/16	42.9	1.589		.068	-.000	.049	1.560		.062		14.8	2.24	2.15	12535	5850
SH-175	1.750	1-3/4	44.4	1.650	±.005	.068		.050	1.618	+.013	.062		15.3	2.31	2.21	12992	6200
SH-177	1.772	-	45.0	1.669	.005*	.068		.051	1.637	-.020	.062		15.4	2.33	2.23	13144	6400
SH-181	1.812	1-13/16	46.0	1.708		.068		.052	1.675		.062		15.6	2.38	2.28	13449	6650
SH-187	1.875	1-7/8	47.6	1.769		.068		.053	1.735		.062		17.3	2.44	2.34	13906	7000
SH-196	1.969	1-31/32	50.0	1.857		.068		.056	1.819		.062		18.0	2.57	2.46	14565	7800
SH-200	2.000	2	50.8	1.886		.068		.057	1.850		.062		19.0	2.60	2.49	14819	8050
SH-206	2.062	2-1/16	52.4	1.946		.086		.058	1.906		.078		25.0	2.68	2.57	19234	8450
SH-212	2.125	2-1/8	54.0	2.003		.086		.061	1.964		.078		26.1	2.78	2.66	19793	9150
SH-215	2.156	2-5/32	54.8	2.032		.086		.062	1.993		.078		26.3	2.81	2.69	20097	9450
SH-225	2.250	2-1/4	57.1	2.120		.086		.065	2.081	+.015	.078	±.003	27.7	2.88	2.76	21011	10350
SH-231	2.312	2-5/16	58.7	2.178		.086		.067	2.139	-.025	.078		28.0	2.94	2.81	21518	10950
SH-237	2.375	2-3/8	60.3	2.239		.086		.068	2.197		.078		29.2	3.06	2.93	22127	11400
SH-243	2.438	2-7/16	61.9	2.299		.086		.069	2.255		.078		29.5	3.07	2.94	22736	11900
SH-250	2.500	2-1/2	63.5	2.360		.086		.070	2.313		.078		29.7	3.17	3.03	23345	12350
SH-255	2.559	-	65.0	2.419		.086		.070	2.377		.078		33.9	3.18	3.04	23853	12650
SH-262	2.625	2-5/8	66.7	2.481	±.006	.086	+.005	.072	2.428		.078		35.0	3.30	3.16	24462	13350
SH-268	2.688	2-11/16	68.3	2.541	.006*	.086	-.000	.073	2.485		.078		36.0	3.37	3.23	25071	13850
SH-275	2.750	2-3/4	69.8	2.602		.103		.074	2.543		.093		42.5	3.48	3.34	30551	14400
SH-287	2.875	2-7/8	73.0	2.721		.103		.077	2.659		.093		48.5	3.60	3.45	31973	15650
SH-293	2.938	2-15/16	74.6	2.779		.103		.079	2.717	+.020	.093		50.0	3.66	3.51	32683	16400
SH-300	3.000	3	76.2	2.838		.103		.081	2.775	-.030	.093		52.0	3.60	3.44	33394	17200
SH-306	3.062	3-1/16	77.8	2.898		.103		.082	2.832		.093		47.5	3.74	3.58	34003	17750
SH-312	3.125	3-1/8	79.4	2.957		.103		.084	2.892		.093		58.0	3.85	3.69	34815	18550
SH-315	3.156	3-5/32	80.2	2.986		.103		.085	2.920		.093		59.0	3.88	3.71	35119	18950
SH-325	3.250	3-1/4	82.5	3.076		.103		.087	3.006		.093		62.0	3.93	3.76	36134	20000
SH-334	3.346	3-11/32	85.0	3.166		.103		.090	3.092		.093		64.0	4.02	3.85	37251	21000
SH-343	3.438	3-7/16	87.3	3.257		.103		.090	3.179		.093		66.0	4.14	3.96	38266	21900
SH-350	3.500	3-1/2	88.9	3.316		.120		.092	3.237		.109		72.0	4.16	3.98	45574	22800

\* F.I.M. (FULL INDICATOR MOVEMENT)- MAXIMUM ALLOWABLE DEVIATION OF CONCENTRICITY BETWEEN GROOVE & SHAFT.  
 † BASED ON HOUSINGS/SHAFTS MADE OF COLD ROLLED STEEL. FOR AN EXPLANATION OF FORMULAS USED TO DERIVE THRUST LOAD AND OTHER PERFORMANCE DATA CONTACT THE ROTOR CLIP ENGINEERING DEPARTMENT.  
 \*\*\*FOR PLATED RINGS ADD .002" TO THE LISTED MAXIMUM THICKNESS. MAXIMUM THICKNESS WILL BE A MINIMUM OF .0002" LESS THAN THE LISTED GROOVE WIDTH (W) MINIMUM.





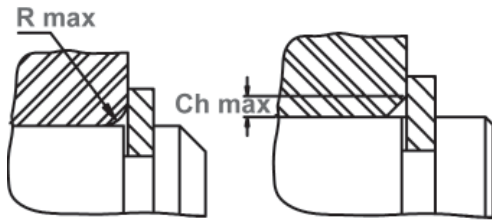

Maximum Corner Radius & Chamfer

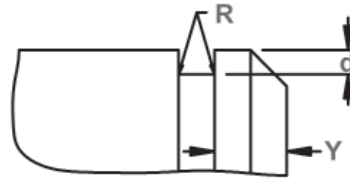

Exploded Groove Profile & Edge Margin (Y)  
Maximum bottom radii (R), sharp corners for ring sizes -12 thru -23; .003 for ring sizes -25 thru -35; .005 for sizes -37 thru -100; .010 for ring sizes -102 thru -1000



Lug Design For Sizes SH-12 thru SH-23



Alternate Design Manufacturer's Option

RING NO.	LUG HEIGHT		MAXIMUM SECTION		MINIMUM SECTION		HOLE DIAMETER		GAGING DIA.	ALLOWABLE CORNER RADII & CHAMFERS		MAX. LOAD w/ R max or Ch max (lbs.)	EDGE MARGIN	R.P.M. LIMITS Standard Material
	H	Tol.	S max	Tol.	S min	Tol.	R	Tol.		Gd Max.	R max			
	SH-118	.182		.132		.072		.078		1.325	.064	.0385	1950	.105
SH-125	.183		.140		.076		.078		1.396	.068	.041	1950	.111	17000
SH-131	.183		.146		.076		.078		1.458	.068	.041	1950	.120	16500
SH-137	.184		.152		.082		.078		1.529	.072	.043	1950	.126	16000
SH-143	.184		.160		.086		.078		1.600	.076	.045	1950	.132	15000
SH-150	.214	±.004	.168	±.006	.091	±.006	.120		1.668	.079	.047	1950	.141	14800
SH-156	.235		.172		.093		.125		1.740	.082	.049	3000	.141	14000
SH-162	.235		.180		.097		.125		1.812	.087	.052	3000	.144	13200
SH-168	.235		.184		.099		.125		1.877	.090	.054	3000	.148	13000
SH-175	.237		.188		.101		.125		1.945	.091	.054	3000	.150	12200
SH-177	.237		.190		.102		.125		1.967	.092	.055	3000	.154	11700
SH-181	.262		.192		.102		.125		2.010	.092	.055	3000	.156	11500
SH-187	.262		.196		.104		.125		2.076	.094	.056	3000	.159	11000
SH-196	.262		.200		.106		.125		2.170	.094	.056	3000	.168	10500
SH-200	.262		.204		.108		.125		2.205	.096	.057	3000	.171	10000
SH-206	.267		.208		.111		.125		2.275	.098	.059	5000	.174	9600
SH-212	.280		.212		.113		.125	+0.015 -0.002	2.337	.098	.059	5000	.183	9500
SH-215	.280		.212		.113		.125		2.366	.097	.058	5000	.186	9400
SH-225	.280		.220		.116		.125		2.466	.100	.060	5000	.195	9200
SH-231	.280		.222		.118		.125		2.528	.100	.060	5000	.201	9000
SH-237	.292		.224		.119		.125		2.591	.100	.060	5000	.204	8800
SH-243	.268	±.005	.228	±.007	.120	±.007	.125		2.657	.102	.061	5000	.207	8600
SH-250	.292		.232		.122		.125		2.724	.104	.062	5000	.210	8400
SH-255	.292		.238		.125		.125		2.792	.108	.065	5000	.210	8200
SH-262	.292		.242		.127		.125		2.860	.1095	.066	5000	.216	8000
SH-268	.292		.292		.129		.125		2.926	.1115	.067	5000	.219	7900
SH-275	.324		.248		.131		.125		2.992	.112	.067	7350	.222	7600
SH-287	.324		.256		.133		.125		3.122	.115	.069	7350	.231	7300
SH-293	.324		.260		.136		.125		3.187	.116	.070	7350	.237	7200
SH-300	.264		.264		.138		.125		3.252	.117	.070	7350	.243	6700
SH-306	.300		.300		.131		.125		3.294	.107	.064	7350	.246	6600
SH-312	.324		.272		.141		.125		3.383	.120	.072	7350	.252	6600
SH-315	.324		.274		.143		.125		3.415	.1205	.072	7350	.255	6500
SH-325	.300		.300	±.008	.145	±.008	.125		3.515	.123	.074	7350	.261	6400
SH-334	.300		.300		.147		.125		3.613	.126	.076	7350	.270	6000
SH-343	.300		.300		.148		.125		3.712	.129	.077	7350	.270	5900
SH-350	.285		.285		.148		.125		3.764	.122	.073	10500	.276	5900

FOR HARDNESS SPECIFICATIONS, SEE END OF THIS SECTION.

Note: Specifications listed within the catalog tables reflect Rotor Clip's standard commercial production dimensions. Published retaining ring standards including Military (MIL-DTL-21248D) / ASME / NAS / ANSI may require parts with alternative geometry. Please contact Rotor Clip Technical Sales Department to clarify conformance to specific requirements. (Tech@rotorclip.com or +1-732-469-7333.)



# SH Shaft Rings

**Axially Assembled, External**  
Once installed in the groove of a shaft, the portion of the ring protruding from the groove (also called a "shoulder") holds an assembly in place.

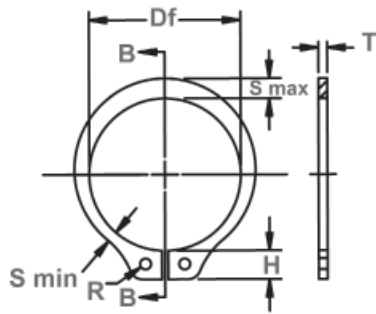

Free Diameter & Ring Measurements with Section B-B

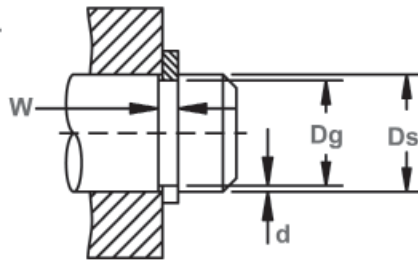

Shaft Diameter & Groove Dimensions

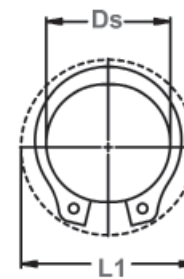

Clearance Diameter Expanded Over Shaft



Clearance Diameter & Gaging Diameter Released in Groove.

RING NO.	SHAFT DIAMETER			GROOVE SIZE			RING SIZE & WEIGHT				CLEARANCE DIA.		THRUST LD. (lbs.) Sqr. Corner Abutment				
				DIAMETER		WIDTH	DEPTH	FREE DIAMETER		THICKNESS***		Weight Per 1000 pcs.	Ex-panded over Shaft	Re-leased in Groove	Ring Safety Factor of 4	Groove Safety Factor of 2	
	Ds DEC	Ds FRAC	Ds mm	Dg	Tol.	W	Tol.	d	Df	Tol.	T						Tol.
SH-354	3.543	-	90.0	3.357	.120		.093	3.277		.109			73.0	4.25	4.07	46183	23300
SH-362	3.625	3-5/8	92.1	3.435	.120		.095	3.352		.109			76.0	4.36	4.17	47299	24300
SH-368	3.688	3-11/16	93.7	3.493	.120		.097	3.410		.109			80.0	4.33	4.31	48010	25300
SH-375	3.750	3-3/4	95.2	3.552	±.006	.120	+.005	.099	3.468	+.020	.109	±.003	83.0	4.52	4.33	48822	26200
SH-387	3.875	3-7/8	98.40	3.673	.006*	.120	-.000	.101	3.584	-.030	.109		88.0	4.64	4.44	50446	27700
SH-393	3.938	3-15/16	100.0	3.734		.120		.102	3.642		.109		95.0	4.70	4.50	51359	28400
SH-400	4.000	4	101.6	3.792		.120		.104	3.700		.109		101.0	4.76	4.56	52171	29400
SH-412	4.125	4-1/8	104.8	3.915		.120		.105	3.800		.109		101.2	5.00	4.78	53200	29800
SH-425	4.250	4-1/4	108.0	4.065		.120		.092	3.989		.109		112.0	4.98	4.80	55419	27600
SH-437	4.375	4-3/8	111.1	4.190		.120		.092	4.106		.109		115.0	5.22	5.04	57043	28400
SH-450	4.500	4-1/2	114.3	4.310		.120		.095	4.223		.109		132.0	5.37	5.18	58667	30200
SH-475	4.750	4-3/4	120.6	4.550		.120		.100	4.458		.109		113.0	5.74	5.52	61915	33600
SH-500	5.000	5	127.0	4.790		.120		.105	4.692		.109		149.0	5.85	5.64	65163	37100
SH-525	5.250	5-1/4	133.3	5.030		.139		.110	4.927		.125		190.0	6.17	5.95	78460	40800
SH-550	5.500	5-1/2	139.7	5.265	±.007	.139	+.006	.117	5.162	+.020	.125	±.004	202.5	6.63	6.39	82215	45500
SH-575	5.750	5-3/4	146.0	5.505	.006*	.139	-.000	.122	5.396	-.040	.125		220.0	6.93	6.69	85971	49600
SH-600	6.000	6	152.4	5.745		.139		.127	5.631		.125		210.0	7.21	6.95	89625	53800
SH-625	6.250	6-1/4	158.7	5.985		.174		.132	5.866		.156		282.0	7.48	7.22	116522	58300
SH-650	6.500	6-1/2	165.1	6.225		.174		.137	6.100	+.020	.156		330.0	7.80	7.45	121191	62900
SH-675	6.750	6-3/4	171.4	6.465		.174		.142	6.335	-.050	.156		356.0	8.10	7.82	125860	67700
SH-700	7.000	7	177.8	6.705		.174		.147	6.570		.156		371.0	8.23	7.94	130529	72700
SH-725	7.250	7-1/4	184.2	6.942		.209		.154	6.775		.187		510.0	8.70	8.40	162096	78900
SH-750	7.500	7-1/2	190.5	7.180		.209		.160	7.009		.187		534.0	8.98	8.66	167678	84800
SH-775	7.750	7-3/4	196.9	7.420	±.008	.209	+.008	.165	7.243	+.050	.187	±.005	545.0	9.21	8.88	173261	90450
SH-800	8.000	8	203.2	7.660	.006*	.209	-.000	.170	7.478	-.130	.187		640.0	9.61	9.26	178843	96100
SH-825	8.250	8-1/4	209.6	7.900		.209		.175	7.712		.187		665.0	9.87	9.52	184426	102100
SH-850	8.500	8-1/2	215.9	8.140		.209		.180	7.947		.187		692.0	10.12	9.76	190008	108100
SH-875	8.750	8-3/4	222.3	8.380		.209		.185	8.181		.187		712.0	10.40	10.00	195591	114450
SH-900	9.000	9	228.6	8.620		.209		.190	8.415		.187		737.0	10.60	10.22	201173	120800
SH-925	9.250	9-1/4	234.9	8.860		.209		.195	8.650		.187		760.0	10.85	10.50	206756	128225
SH-950	9.500	9-1/2	241.3	9.100		.209		.200	8.885		.187		785.0	11.10	10.70	212338	134200
SH-975	9.750	9-3/4	247.6	9.338		.209		.206	9.120		.187		845.0	11.35	10.95	217921	142000
SH-1000	10.000	10	254.0	9.575		.209		.212	9.355		.187		910.0	11.60	11.20	223503	149800

\* F.I.M. (FULL INDICATOR MOVEMENT)- MAXIMUM ALLOWABLE DEVIATION OF CONCENTRICITY BETWEEN GROOVE & SHAFT.

† BASED ON HOUSINGS/SHAFTS MADE OF COLD ROLLED STEEL. FOR AN EXPLANATION OF FORMULAS USED TO DERIVE THRUST LOAD AND OTHER PERFORMANCE DATA CONTACT THE ROTOR CLIP ENGINEERING DEPARTMENT.

\*\*\*FOR PLATED RINGS ADD .002" TO THE LISTED MAXIMUM THICKNESS. MAXIMUM THICKNESS WILL BE A MINIMUM OF .0002" LESS THAN THE LISTED GROOVE WIDTH (W) MINIMUM.

Note: Specifications listed within the catalog tables reflect Rotor Clip's standard commercial production dimensions. Published retaining ring standards including Military (MIL-DTL-21248D) / ASME / NAS / ANSI may require parts with alternative geometry. Please contact Rotor Clip Technical Sales Department to clarify conformance to specific requirements. (Tech@rotorclip.com or +1-732-469-7333.)

HARDNESS RANGES: STAINLESS STEEL RINGS (PH 15-7MO)

RING TYPE	SIZE RANGE	SCALE	ROCKWELL HARDNESS
SH	25-81	30N	63-69.5
	87+	C	44-51



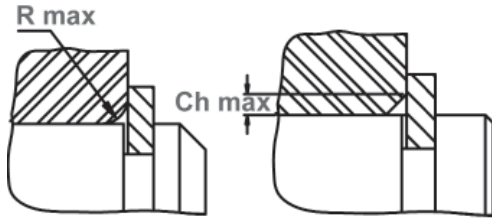

Maximum Corner Radius & Chamfer

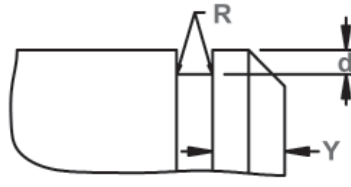

Exploded Groove Profile & Edge Margin (Y)  
Maximum bottom radii (R), sharp corners for ring sizes -12 thru -23; .003 for ring sizes -25 thru -35; .005 for sizes -37 thru -100; .010 for ring sizes -102 thru -1000



Lug Design For Sizes SH-12 thru SH-23

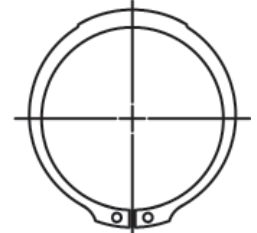

Alternate Design Manufacturer's Option

RING NO.	LUG HEIGHT		MAXIMUM SECTION		MINIMUM SECTION		HOLE DIAMETER		GAGING DIA.	ALLOWABLE CORNER RADII & CHAMFERS		MAX. LOAD w/ R max or Ch max (lbs.)	EDGE MARGIN	R.P.M. LIMITS Standard Material
	H	Tol.	S max	Tol.	S min	Tol.	R	Tol.		Gd Max.	R max			
SH-354	.310		.310		.149		.125		3.809	.123	.074	10500	.279	5800
SH-362	.310		.310		.153		.125		3.898	.127	.076	10500	.285	5700
SH-368	.310		.310		.156		.125	+.015	3.966	.130	.078	10500	.291	5600
SH-375	.342	±.005	.342	±.008	.160	±.008	.125	-.002	4.037	.133	.080	10500	.297	5500
SH-387	.310		.310		.163		.125		4.169	.137	.082	10500	.303	5100
SH-393	.310		.310		.163		.125		4.230	.137	.082	10500	.306	5200
SH-400	.342		.342		.163		.125		4.288	.135	.081	10500	.312	5000
SH-412	.380		.318		.165		.125		4.410	.135	.081	10500	.315	4900
SH-425	.342		.342		.176		.125		4.558	.146	.088	10500	.276	4800
SH-437	.342		.342		.176		.125		4.683	.146	.088	10500	.276	4700
SH-450	.405		.405		.185		.125		4.860	.102	.061	10500	.285	4500
SH-475	.405		.405		.136		.125		4.996	.115	.069	10500	.300	4200
SH-500	.405	±.008	.405	±.010	.194	±.010	.156		5.346	.165	.099	10500	.315	4000
SH-525	.435		.435		.211		.156		5.605	.169	.101	13500	.330	3900
SH-550	.497		.435		.209		.156		5.867	.175	.105	13500	.351	3700
SH-575	.518		.435		.220		.156		6.134	.184	.110	13500	.366	3500
SH-600	.540		.435		.211		.156		6.302	.143	.086	13500	.381	3400
SH-625	.561		.485		.176		.156		6.568	.148	.089	21000	.396	3100
SH-650	.586		.485		.236		.156		6.905	.191	.114	21000	.411	3000
SH-675	.608		.515		.246		.187	+.020	7.172	.200	.120	21000	.426	3000
SH-700	.530		.515		.256		.187	-.005	7.439	.208	.125	21000	.441	2900
SH-725	.660		.545		.267		.187		7.700	.214	.128	30000	.460	2800
SH-750	.676		.545		.277		.187		7.963	.220	.132	30000	.480	2700
SH-775	.660	±.012	.560	±.015	.285	±.015	.187		8.228	.227	.136	30000	.495	2600
SH-800	.735		.560		.294		.187		8.493	.235	.141	30000	.510	2500
SH-825	.735		.580		.304		.187		8.758	.242	.146	30000	.525	2400
SH-850	.735		.580		.314		.187		9.023	.250	.150	30000	.540	2300
SH-875	.735		.591		.322		.187		9.280	.258	.155	30000	.555	2200
SH-900	.735		.609		.333		.187		9.557	.267	.160	30000	.570	2200
SH-925	.735		.625		.341		.187		9.830	.274	.164	30000	.585	2100
SH-950	.735		.642		.350		.187		10.086	.281	.168	30000	.600	2100
SH-975	.735		.658		.358		.187		10.340	.287	.172	30000	.618	2000
SH-1000	.735		.675		.367		.187		10.610	.294	.176	30000	.636	2000

LARGER SIZES MAY BE AVAILABLE UPON REQUEST.

HARDNESS RANGES: CARBON STEEL RINGS (SAE 1060-1090)

RING TYPE	SIZE RANGE	SCALE	ROCKWELL HARDNESS
SH	12-23	15N	84-86
	25-46	30N	69.5-73
	50-81	30N	66-71
	84-102	C	47-53
	106-343	C	47-52
	350-700	C	44-51
	725-1000	C	40-47

HARDNESS RANGES: BERYLLIUM COPPER RINGS

RING TYPE	SIZE RANGE	SCALE	ROCKWELL HARDNESS
SH	12-23	15N	77-82*
	25-102	30N	56.5-62
	106+	C	37-43

\*HARDNESS CAN NOT BE CHECKED WITH ANY DEGREE OF ACCURACY DIRECTLY ON THESE RINGS.





# HOI Housing Rings

## Axially Assembled, Internal Inverted

Functions like an HO ring in a housing/bore, only the lugs are "reversed." This version reduces the distance the lugs of the standard HO extend into the inner circumference of the housing/bore and allows for another assembly to pass through unimpeded.

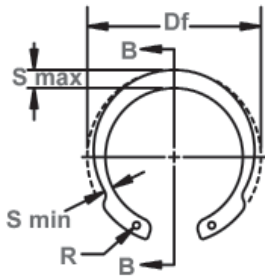

Free Diameter & Ring Measurements with Section B-B

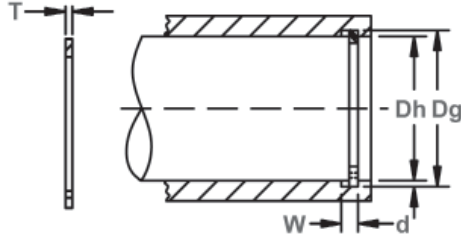

Housing Diameter & Groove Dimensions

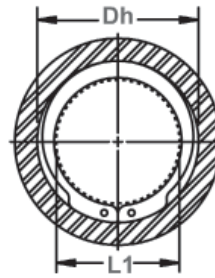

Clearance Diameter Compressed in Housing

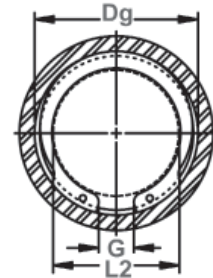

Clearance Diameter & Gap Width Released in Groove

RING NO.	HOUSING DIAMETER			GROOVE SIZE			RING SIZE & WEIGHT				CLEARANCE DIA.			THRUST LD. (lbs.)			
				DIAMETER		WIDTH		DEPTH	FREE DIAMETER		THICKNESS***		Wght. Per 1000 Pcs.	Compressed in housing	Released in groove	Sqr. Corner Abutment	
	Dh DEC	Dh FRACT	Dh mm	Dg	Tol.	W	Tol.	d	Df	Tol.	T	Tol.				L1	L2
HOI-62	.625	5/8	15.9	.665	±.002	.029		.020	.675		.025		0.7	.47	.51	1015	450
HOI-75	.750	3/4	19.0	.796	.004*	.039		.023	.808		.035		1.3	.56	.605	1675	600
HOI-81	.812	13/16	20.6	.862		.046	+ .003	.025	.877	+ .010	.042		2.0	.62	.665	2639	700
HOI-87	.875	7/8	22.2	.931	±.003	.046	- .000	.028	.944	- .005	.042		2.2	.65	.705	2893	850
HOI-93	.938	15/16	23.8	1.000	.004*	.046		.031	1.015		.042		2.8	.70	.755	3147	1000
HOI-100	1.000	1	25.4	1.066		.046		.033	1.081		.042		2.9	.75	.81	3350	1150
HOI-106	1.062	1-1/16	27.0	1.130		.056		.034	1.150		.050		3.8	.80	.87	4212	1250
HOI-112	1.125	1-1/8	28.6	1.197		.056		.036	1.217		.050		4.4	.86	.93	4466	1400
HOI-118	1.188	1-3/16	30.2	1.262		.056		.037	1.283	+ .015	.050	±.002	4.9	.91	.98	4720	1600
HOI-125	1.250	1-1/4	31.7	1.330	±.004	.056		.040	1.351	- .010	.050		5.0	.97	1.05	4974	1750
HOI-131	1.312	1-5/16	33.3	1.396	.005*	.056	+ .004	.042	1.418		.050		5.3	1.02	1.10	5227	1950
HOI-137	1.375	1-3/8	34.9	1.461		.056	- .000	.043	1.486		.050		5.9	1.08	1.16	5481	2100
HOI-143	1.438	1-7/16	36.5	1.528		.056		.045	1.552		.050		6.3	1.13	1.22	5735	2300
HOI-150	1.500	1-1/2	38.1	1.594		.056		.047	1.622		.050		6.8	1.18	1.27	5938	2500
HOI-156	1.562	1-9/16	39.7	1.658		.068		.048	1.688		.062		8.9	1.21	1.30	7714	2650
HOI-162	1.625	1-5/8	41.3	1.725		.068		.050	1.756		.062		10.4	1.27	1.37	8019	2850
HOI-168	1.688	1-11/16	42.9	1.792	±.005	.068		.052	1.823	+ .020	.062		11.9	1.32	1.42	8374	3100
HOI-175	1.750	1-3/4	44.4	1.858	.005*	.068		.054	1.891	- .013	.062		11.8	1.38	1.49	8678	3300
HOI-187	1.875	1-7/8	47.6	1.989		.068		.057	2.025		.062		14.8	1.47	1.58	9287	3750
HOI-200	2.000	2	50.8	2.122		.068		.061	2.160		.062		17.4	1.55	1.67	9896	4300
HOI-206	2.062	2-1/16	52.4	2.186		.086		.062	2.224		.078		23.2	1.59	1.71	12840	4500
HOI-212	2.125	2-1/8	54.0	2.251	±.006	.086	+ .005	.063	2.295		.078		24.3	1.65	1.77	13246	4700
HOI-237	2.375	2-3/8	60.3	2.517	.006*	.086	- .000	.071	2.567	+ .025	.078	±.003	28.6	1.86	2.00	14718	5900
HOI-243	2.438	2-7/16	61.9	2.584		.086		.072	2.634	- .015	.078		30.6	1.91	2.05	15124	6200
HOI-250	2.500	2-1/2	63.5	2.648		.086		.074	2.700		.078		32.1	1.96	2.10	15530	6500
HOI-262	2.625	2-5/8	66.7	2.781		.103		.078	2.840		.093		45.6	2.06	2.21	19488	7200
HOI-275	2.750	2-3/4	69.8	2.914		.103		.082	2.975		.093		47.8	2.16	2.32	20300	7900
HOI-283	2.812	2-13/16	71.4	2.980		.103		.084	3.063		.093		49.5	2.21	2.37	20808	8300
HOI-283	2.835	-	72.0	3.006		.103		.086	3.063		.093		49.5	2.23	2.39	20808	8550
HOI-287	2.875	2-7/8	73.0	3.051		.103		.088	3.105	+ .030	.093		50.1	2.26	2.43	21315	8900
HOI-300	3.000	3	76.2	3.182		.103		.091	3.245	- .020	.093		52.6	2.36	2.53	22229	9600
HOI-315	3.156	3-5/32	80.2	3.348		.120		.096	3.408		.109		69.4	2.50	2.69	27405	10600
HOI-325	3.250	3-1/4	82.5	3.446		.120		.098	3.509		.109		72.6	2.58	2.77	28217	11200
HOI-334	3.346	3-11/32	85.0	3.546		.120		.100	3.611		.109		75.6	2.67	2.87	29029	11700
HOI-350	3.500	3-1/2	88.9	3.710		.120		.105	3.780		.109		80.2	2.82	3.03	30349	12900
HOI-356	3.562	3-9/16	90.5	3.776		.120		.107	3.850		.109		82.4	2.88	3.09	30958	13400
HOI-400	4.000	4	101.6	4.240		.120		.120	4.350		.109		97.4	3.29	3.53	34713	16900

\*F.I.M. (FULL INDICATOR MOVEMENT)-MAXIMUM ALLOWABLE DEVIATION OF CONCENTRICITY BETWEEN GROOVE AND HOUSING.

† BASED ON HOUSING/SHAFTS MADE OF COLD ROLLED STEEL. FOR AN EXPLANATION OF FORMULAS USED TO DERIVE THRUST LOAD AND OTHER PERFORMANCE DATA, CONTACT THE ROTOR CLIP ENGINEERING DEPT.

\*\*\* FOR PLATED RINGS, ADD .002" TO THE LISTED MAXIMUM THICKNESS. MAXIMUM RING THICKNESS WILL BE A MINIMUM OF .0002" LESS THAN THE LISTED GROOVE WIDTH (W) MINIMUM.

Note: Specifications listed within the catalog tables reflect Rotor Clip's standard commercial production dimensions. Published retaining ring standards including Military (MIL-DTL-21248D) / ASME / NAS / ANSI may require parts with alternative geometry. Please contact Rotor Clip Technical Sales Department to clarify conformance to specific requirements. (Tech@rotorclip.com or +1-732-469-7333.)

HARDNESS RANGES: STAINLESS STEEL RINGS (PH 15-7M0)

RING TYPE	SIZE RANGE	SCALE	ROCKWELL HARDNESS
HOI	62-100	30N	63-69.5
	106+	C	44-51



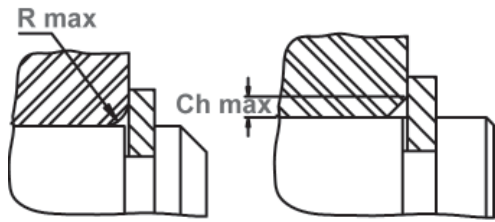

Allowable Corner Radius & Chamfer

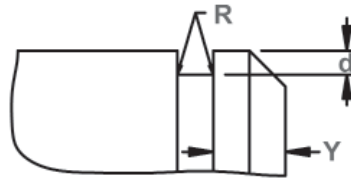

Exploded Groove Profile & Edge Margin (Y) Maximum bottom radii (R),  
.005 for ring sizes  
-62 thru -100; .010 for ring sizes  
-106 thru -400

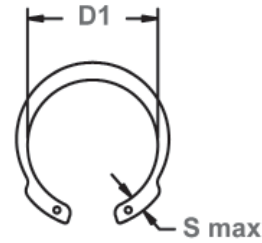

Measuring Free Diameter (Df)  
HOI Series  
 $Df = D1 + 2(S \max)$



Alternate Design  
Manufacturer's  
Option

RING NO.	MAXIMUM SECTION Including lug		MINIMUM SECTION		HOLE DIAMETER		GAP WIDTH Ring in groove	Allowable Corner Radii & Chamfers			MAX LOAD W/R Max or Ch Max	EDGE MARGIN
	S max	Tol.	S min.	Tol.	R	Tol.		G Min	R max	Ch max		
HOI-62	.072	± .004	.036	± .004	.030		.15	.042	.028	400	.060	
HOI-75	.085		.042		.042		.175	.050	.031	850	.069	
HOI-81	.092	± .005	.044	± .005	.042	+.010 -.002	.175	.054	.034	1250	.075	
HOI-87	.099		.047		.042		.20	.057	.036	1250	.084	
HOI-93	.106	± .006	.051	± .006	.042	+.015 -.002	.21	.060	.038	1250	.093	
HOI-100	.113		.054		.042		.225	.064	.040	1250	.099	
HOI-106	.120	± .007	.057	± .007	.050	+.015 -.002	.24	.069	.043	1800	.102	
HOI-112	.123		.059		.050		.24	.070	.044	1800	.108	
HOI-118	.126	± .008	.060	± .008	.050	+.015 -.002	.27	.071	.045	1800	.111	
HOI-125	.129		.061		.050		.29	.071	.045	1800	.120	
HOI-131	.132	± .009	.063	± .009	.050	+.015 -.002	.29	.072	.045	1800	.126	
HOI-137	.135		.065		.050		.33	.074	.046	1800	.129	
HOI-143	.144	± .010	.069	± .010	.076	+.015 -.002	.35	.079	.050	1800	.135	
HOI-150	.148		.070		.076		.33	.081	.051	1800	.141	
HOI-156	.158	± .011	.074	± .011	.076	+.015 -.002	.36	.088	.055	2900	.144	
HOI-162	.162		.077		.076		.385	.090	.056	2900	.150	
HOI-168	.166	± .012	.079	± .012	.076	+.015 -.002	.405	.091	.057	2900	.156	
HOI-175	.170		.082		.076		.42	.093	.058	2900	.162	
HOI-187	.188	± .013	.090	± .013	.076	+.015 -.002	.44	.105	.066	2900	.171	
HOI-200	.208		.100		.076		.48	.118	.074	2900	.183	
HOI-206	.218	± .014	.106	± .014	.094	+.015 -.002	.485	.125	.078	4600	.186	
HOI-212	.223		.108		.094		.49	.128	.080	4600	.189	
HOI-237	.243	± .015	.115	± .015	.094	+.015 -.002	.55	.138	.086	4600	.213	
HOI-243	.248		.117		.094		.57	.141	.088	4600	.216	
HOI-250	.254	± .016	.120	± .016	.094	+.015 -.002	.59	.144	.090	4600	.222	
HOI-262	.266		.128		.109		.60	.150	.094	6700	.234	
HOI-275	.278	± .017	.134	± .017	.109	+.015 -.002	.63	.157	.098	6700	.246	
HOI-283	.286		.139		.109		.61	.162	.102	6700	.252	
HOI-283	.286	± .018	.139	± .018	.109	+.015 -.002	.67	.162	.102	6700	.258	
HOI-287	.290		.139		.109		-	.162	.101	6700	.264	
HOI-300	.302	± .019	.143	± .019	.109	+.015 -.002	.705	.169	.106	6700	.273	
HOI-315	.314		.149		.125		.76	.174	.109	9000	.288	
HOI-325	.318	± .020	.151	± .020	.125	+.015 -.002	-	.176	.110	9000	.294	
HOI-334	.321		.155		.125		.81	.177	.111	9000	.300	
HOI-350	.324	± .021	.154	± .021	.125	+.015 -.002	.84	.175	.110	9000	.315	
HOI-356	.326		.155		.125		.86	.175	.110	9000	.321	
HOI-400	.338	± .022	.161	± .022	.125	+.015 -.002	.93	.174	.108	9000	.360	

LARGER SIZES MAY BE AVAILABLE UPON REQUEST.

HARDNESS RANGES: CARBON STEEL RINGS (SAE 1060-1090)

RING TYPE	SIZE RANGE	SCALE	ROCKWELL HARDNESS
HOI	62 & 75	30N	67.5-72
	81-100	30N	66-71
	106-343	C	47-52
	350+	C	45-50

HARDNESS RANGES: BERYLLIUM COPPER RINGS

RING TYPE	SIZE RANGE	SCALE	ROCKWELL HARDNESS
HOI	62-100	30N	56.5-62
	106+	C	37-43





# SHI Shaft Rings

## Axially Assembled, External Inverted

Functions like an SH ring on a shaft, only the lugs are "reversed." This version reduces the distance the lugs of the standard SH extend beyond the circumference of the shaft. The shaft can then be used in an application where clearance is minimal.

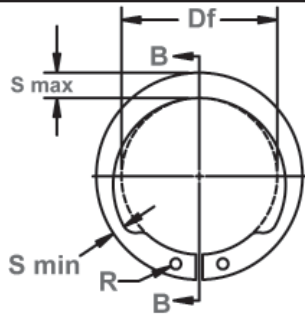

Free Diameter & Ring Measurements with Section B-B

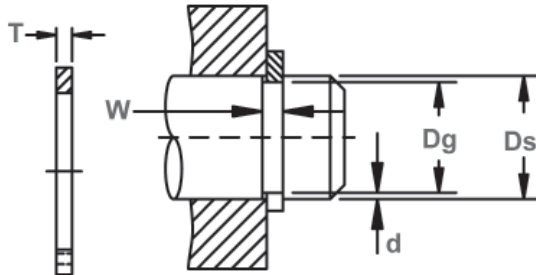

Shaft Diameter & Groove Dimensions

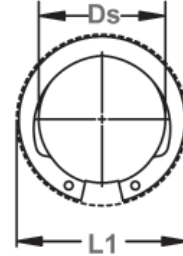

Clearance Diameter Expanded Over Shaft

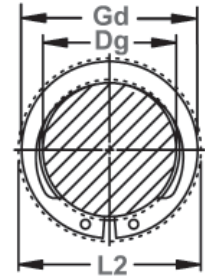

Clearance Diameter & Gaging Diameter Released in Groove

RING NO.	SHAFT DIAMETER			GROOVE SIZE				RING SIZE & WEIGHT				CLEAR. DIA.			† THRUST LD. (lbs.)		
				DIAMETER		WIDTH		DEPTH	FREE DIAMETER		THICKNESS***		Weight Per 1000 Pcs.	Expanded over shaft	Re-leased in groove	Ring Safety factor of 4	Groove Safety factor of 2
	Ds DEC	Ds FRACT	Ds mm	Dg	Tol.	W	Tol.	d	Df	Tol.	T	Tol.					
SHI-50	.500	1/2	12.7	.468	±.002	.039		.016	.461		.035		1.0	.67	.645	1117	280
SHI-56	.562	9/16	14.3	.530	.004*	.039		.016	.521		.035		1.4	.75	.72	1269	320
SHI-59	.594	19/32	15.1	.559		.039		.017	.550		.035		1.6	.79	.76	1320	370
SHI-62	.625	5/8	15.9	.588		.039		.018	.579		.035		1.6	.83	.80	1421	400
SHI-68	.688	11/16	17.5	.646		.046		.021	.635		.042		2.5	.91	.87	2335	500
SHI-75	.750	3/4	19.0	.704	±.003	.046	+.003	.023	.693	+.005	.042		2.8	.99	.95	2538	600
SHI-78	.781	25/32	19.8	.733	.004*	.046	-.000	.024	.722	-.010	.042		3.1	1.04	1.00	2639	650
SHI-81	.812	13/16	20.6	.762		.046		.025	.751		.042		3.3	1.08	1.03	2690	700
SHI-87	.875	7/8	22.2	.821		.046		.027	.810		.042		3.8	1.15	1.10	2893	850
SHI-93	.938	15/16	23.8	.882		.046		.028	.867		.042		4.5	1.23	1.18	3147	900
SHI-100	.984	63/64	25.0	.926		.046		.029	.925		.042	±.002	4.8	1.30	1.25	3350	1000
SHI-100	1.000	1	25.4	.940		.046		.030	.925		.042		4.8	1.31	1.26	3350	1050
SHI-106	1.062	1-1/16	27.0	.998		.056		.032	.982		.050		6.2	1.38	1.32	4212	1200
SHI-112	1.125	1-1/8	28.6	1.059		.056		.033	1.041		.050		6.7	1.45	1.39	4466	1300
SHI-118	1.188	1-3/16	30.2	1.118		.056		.035	1.098	+.010	.050		7.2	1.52	1.46	4720	1450
SHI-125	1.250	1-1/4	31.7	1.176	±.004	.056	+.004	.037	1.156	-.015	.050		7.6	1.59	1.52	4974	1600
SHI-131	1.312	1-5/16	33.3	1.232	.005*	.056	-.000	.040	1.214		.050		8.2	1.66	1.58	5227	1850
SHI-137	1.375	1-3/8	34.9	1.291		.056		.042	1.272		.050		8.4	1.73	1.65	5481	2050
SHI-143	1.438	1-7/16	36.5	1.350		.056		.044	1.333		.050		9.1	1.80	1.72	5735	2200
SHI-150	1.500	1-1/2	38.1	1.406		.056		.047	1.387		.050		9.8	1.87	1.78	5938	2500
SHI-156	1.562	1-9/16	39.7	1.468		.068		.047	1.446		.062		12.9	1.95	1.86	7714	2600
SHI-162	1.625	1-5/8	41.3	1.529		.068		.048	1.503		.062		13.4	2.02	1.93	8019	2750
SHI-177	1.750	1-3/4	44.4	1.650		.068		.050	1.637		.062		16.1	2.18	2.08	8628	3100
SHI-177	1.772	-	45.0	1.669	±.005	.068		.051	1.637	+.013	.062		16.1	2.20	2.10	8628	3200
SHI-181	1.812	1-13/16	46.0	1.708	.005*	.068		.052	1.675	-.020	.062		17.3	2.24	2.14	8983	3300
SHI-196	1.969	1-31/32	50.0	1.857		.068		.056	1.819		.062		20.5	2.43	2.32	9693	3900
SHI-200	2.000	2	50.8	1.886		.068		.057	1.850		.062		20.7	2.47	2.36	9896	4000
SHI-215	2.125	2-1/8	54.0	2.003		.086		.061	1.993		.078	±.003	30.0	2.62	2.50	13195	4550
SHI-215	2.156	2-5/32	54.8	2.032		.086		.062	1.993	+.015	.078		30.0	2.65	2.53	13195	4700
SHI-250	2.500	2-1/2	63.5	2.360		.086		.070	2.313	-.025	.078		43.5	3.05	2.92	15530	6200
SHI-275	2.750	2-3/4	69.8	2.602	±.006	.103	+.005	.074	2.543		.093		57.9	3.34	3.20	20402	7200
SHI-287	2.875	2-7/8	73.0	2.721	.006*	.103	-.000	.077	2.659		.093		64.5	3.49	3.34	21315	7800
SHI-315	3.156	3-5/32	80.2	2.986		.103		.085	2.920	+.020	.093		77.0	3.82	3.66	23447	9400
SHI-325	3.250	3-1/4	82.5	3.076		.103		.087	3.006	-.030	.093		77.5	3.93	3.76	24056	10000
SHI-350	3.500	3-1/2	88.9	3.316		.120		.092	3.237		.109		107.0	4.22	4.04	30349	11500
SHI-393	3.938	3-15/16	100.0	3.734		.120		.102	3.642		.109		123.0	4.71	4.51	34206	14000

\* F.I.M. (FULL INDICATOR MOVEMENT)-MAXIMUM ALLOWABLE DEVIATION OF CONCENTRICITY BETWEEN GROOVE AND SHAFT.  
 † BASED ON HOUSINGS/SHAFTS MADE OF COLD ROLLED STEEL. FOR AN EXPLANATION OF FORMULAS USED TO DERIVE THRUST LOAD AND OTHER PERFORMANCE DATA, CONTACT THE ROTOR CLIP ENGINEERING DEPARTMENT.  
 \*\*\*FOR PLATED RINGS, ADD .002" TO THE LISTED MAXIMUM RING THICKNESS. MAXIMUM RING THICKNESS WILL BE A MINIMUM OF .0002" LESS THAN THE LISTED GROOVE WIDTH (W) MINIMUM.

Note: Specifications listed within the catalog tables reflect Rotor Clip's standard commercial production dimensions. Published retaining ring standards including Military (MIL-DTL-21248D) / ASME / NAS / ANSI may require parts with alternative geometry. Please contact Rotor Clip Technical Sales Department to clarify conformance to specific requirements. (Tech@rotorclip.com or +1-732-469-7333.)

HARDNESS RANGES: STAINLESS STEEL RINGS (PH 15-7MO)			
RING TYPE	SIZE RANGE	SCALE	ROCKWELL HARDNESS
SHI	50-81	30N	63-69.5
	87+	C	44-51



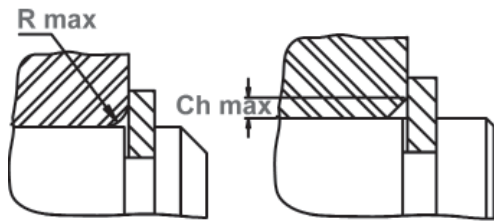

Maximum Corner Radius & Chamfer

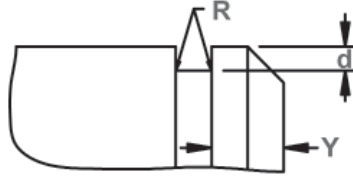

Exploded Groove Profile & Edge Margin (Y)  
Maximum bottom radii (R), .005 for ring sizes -50 thru -100; .010 for ring sizes -106 thru -393



Measuring Free Diameter (Df) SHI Series  
Df = D1 - 2(S max)

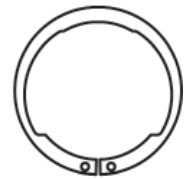

Alternate Design  
Manufacturer's Option

RING NO.	MAXIMUM SECTION (Including Lug)		MINIMUM SECTION		HOLE DIAMETER		GAGING DIAMETER	ALLOWABLE CORNER RADII & CHAMFERS			MAX. LOAD w/R max or Ch max (in lbs.)	EDGE MARGIN		R.P.M. LIMITS Standard material		
	S max	Tol.	S min	Tol.	R	Tol.		Gd Max	R max	Ch max		P'r	Y			
SHI-50	.080	±.004	.041	±.004	.042	+.010 -.002	.64	.051	.032	680	.048	40000				
SHI-56	.088		.043		.042		.715	.057	.036	680	.048		35000			
SHI-59	.092		.046		.042		.75	.059	.037	680	.052		32000			
SHI-62	.096		.048		.042		.79	.062	.039	680	.055		30000			
SHI-68	.104	±.005	.052	±.005	.042	+.010 -.002	.87	.066	.042	1000	.063	28000				
SHI-75	.112		.056		.042		.945	.071	.045	1000	.069		26500			
SHI-78	.116		.057		.042		.98	.073	.046	1000	.072		25500			
SHI-81	.120		.060		.050		1.02	.076	.048	1000	.075		24500			
SHI-87	.128		.064		.050		1.095	.080	.051	1000	.081		23000			
SHI-93	.136		.068		.050		1.17	.086	.054	1000	.084		21500			
SHI-100	.144		.072		.050		1.24	.091	.057	1000	.087		20000			
SHI-100	.144		.072		.050		1.25	.091	.057	1000	.090		20000			
SHI-106	.147	±.006	.073	±.006	.078	+.015 -.002	1.31	.092	.058	1460	.096	19000				
SHI-112	.150		.075		.078		1.38	.093	.059	1460	.099		18800			
SHI-118	.153		.076		.078		1.45	.094	.059	1460	.105		18000			
SHI-125	.157		.079		.078		1.52	.096	.060	1460	.111		17000			
SHI-131	.161		.080		.078		1.58	.097	.061	1460	.120		16500			
SHI-137	.165		.082		.078		1.65	.098	.061	1460	.126		16000			
SHI-143	.169		.085		.078		1.715	.100	.063	1460	.132		15000			
SHI-150	.173		.086		.078		1.775	.100	.063	1460	.141		14800			
SHI-156	.178		.089		.078		1.85	.104	.066	2250	.141		14000			
SHI-162	.183		.092		.078		1.92	.108	.067	2250	.144		13200			
SHI-177	.196		.098		.078		2.07	.116	.073	2250	.150		11700			
SHI-177	.196		.098		.078		2.09	.116	.073	2250	.153		11700			
SHI-181	.199		.100		.078		2.13	.117	.074	2250	.156		11500			
SHI-196	.212		.106		.078		2.31	.124	.078	2250	.168		10500			
SHI-200	.216		.108		.078		2.35	.127	.080	2250	.171		10000			
SHI-215	.229		±.007		.117		±.007	.120	+.015 -.002	2.49	.133		.084	3750	.183	9400
SHI-215	.229	.117		.120	2.52	.133		.084		3750	.186	9400				
SHI-250	.250	.130		.120	2.91	.151		.095		3750	.210	8400				
SHI-275	.280	.140		.120	3.19	.165		.103		5500	.222	7600				
SHI-287	.290	.145		.120	3.33	.170		.107		5500	.231	7300				
SHI-315	.316	.159		.120	3.65	.185		.116		5500	.255	6500				
SHI-325	.324	±.008		.162	±.008	.120		+.015 -.002		3.75	.190	.118	5500	.261	6400	
SHI-350	.345			.173		.125				4.03	.202	.127	7850	.276		
SHI-393	.368		.183	.125		4.50	.212		.133	7850	.306	5200				

LARGER SIZES MAY BE AVAILABLE UPON REQUEST.

HARDNESS RANGES: CARBON STEEL RINGS (SAE 1060-1090)

RING TYPE	SIZE RANGE	SCALE	ROCKWELL HARDNESS
SHI	50-81	30N	66-71
	87-102	C	47-53
	106-343	C	47-52
	350+	C	45-50

HARDNESS RANGES: BERYLLIUM COPPER RINGS

RING TYPE	SIZE RANGE	SCALE	ROCKWELL HARDNESS
SHI	50-81	30N	56.5-62
	87+	C	37-43



# SHR Shaft Rings

## Axially Assembled, External Reinforced

The SHR is an extra thick version of a regular SH retaining ring. As such, it is stronger and can withstand greater thrust loads than its standard counterpart.

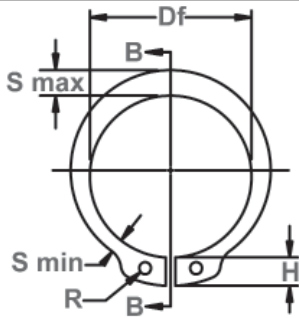

Free Diameter & Ring Measurements with Section B-B

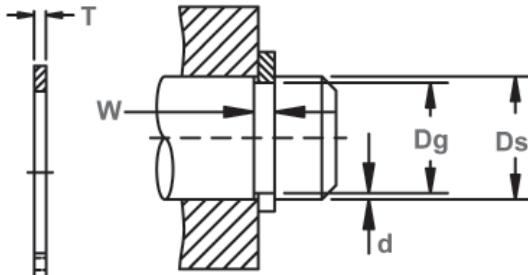

Shaft Diameter & Groove Dimensions

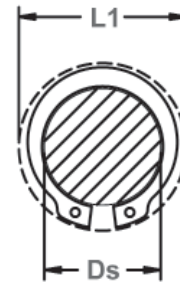

Clearance Diameter Expanded Over Shaft



Clearance Diameter & Gaging Diameter Released in Groove

RING NO.	SHAFT DIAMETER			GROOVE SIZE			RING SIZE & WEIGHT				CLEAR. DIA.			THRUST LD. (lbs.)			
				DIAMETER		WIDTH	DEPTH	FREE DIAMETER		THICKNESS***	Weight Per 1000 pcs.	Expanded over shaft	Re-leased in groove	Sqr. corner abutment			
	Ds DEC	Ds FRAC	Ds mm	Dg	Tol.	W	Tol.	d	Df	Tol.				T	Tol.	lbs.	L1
SHR-39	.394	-	10.0	.368	+.001	.039		.013	.362	+.003	.035		.70	.61	.58	2030	700
SHR-42	.428	-	10.9	.402	-.002	.039	+.003	.013	.394	-.008	.035		.86	.65	.62	2335	800
SHR-47	.473	-	12.0	.444	.002*	.046	-.000	.015	.435		.042		1.4	.69	.66	3045	1000
SHR-50	.500	1/2	12.7	.468		.056		.016	.460		.050	±.002	1.6	.75	.72	3959	1100
SHR-59	.591	-	15.0	.555		.056	+.004	.018	.543		.050		2.2	.86	.83	4568	1500
SHR-62	.625	5/8	15.9	.588		.056	-.000	.019	.575		.050		2.3	.90	.86	4872	1600
SHR-66	.669	-	17.0	.629		.056		.020	.616	+.005	.050		2.6	.94	.90	5278	1900
SHR-75	.750	3/4	19.0	.704	+.001	.086		.023	.689	-.010	.078		5.6	1.12	1.08	9135	2400
SHR-75	.787	-	20.0	.740	-.003	.086		.024	.689		.078		5.6	1.16	1.12	9135	2400
SHR-87	.875	7/8	22.2	.821	.002*	.086		.027	.804		.078		7.5	1.25	1.20	10556	3300
SHR-98	.984	63/64	25.0	.925		.086		.030	.906		.078		7.8	1.36	1.30	11673	4000
SHR-98	1.000	1	25.4	.938		.086		.031	.906		.078		7.8	1.37	1.31	11673	4000
SHR-106	1.062	1-1/16	27.0	.998		.103		.032	.978		.093		11.5	1.52	1.46	15225	4800
SHR-112	1.125	1-1/8	28.6	1.059		.103	+.005	.033	1.036		.093	±.003	12.5	1.58	1.52	16240	5200
SHR-118	1.181	-	30.0	1.111		.103	-.000	.035	1.087	+.010	.093		13.5	1.64	1.57	16748	5600
SHR-118	1.188	1-3/16	30.2	1.111	+.002	.103		.038	1.087	-.015	.093		13.5	1.64	1.57	16748	5600
SHR-125	1.250	1-1/4	31.7	1.174	-.004	.103		.038	1.150		.093		14.9	1.70	1.63	17763	6500
SHR-131	1.312	1-5/16	33.3	1.234	.004*	.103		.039	1.208		.093		16.0	1.77	1.69	18270	7400
SHR-137	1.375	1-3/8	34.9	1.291		.103		.042	1.268		.093		17.8	1.83	1.75	19793	8200
SHR-137	1.378	-	35.0	1.291		.103		.044	1.268		.093		17.8	1.83	1.75	19793	8200
SHR-150	1.500	1-1/2	38.1	1.406		.120		.047	1.380		.109		27.0	2.08	1.98	24868	10000
SHR-156	1.562	1-9/16	39.7	1.468		.120		.047	1.437		.109		31.0	2.14	2.05	26390	10400
SHR-156	1.575	-	40.0	1.480		.120		.048	1.437		.109		31.0	2.15	2.06	26930	10400
SHR-175	1.750	1-3/4	44.4	1.650		.120		.050	1.608		.109		33.4	2.34	2.25	29435	12400
SHR-175	1.772	-	45.0	1.669	+.003	.120		.052	1.608	+.013	.109		33.4	2.37	2.27	29435	12400
SHR-193	1.938	1-15/16	49.2	1.826	-.004	.139		.056	1.782	-.020	.125	±.004	48.0	2.58	2.48	37555	15300
SHR-193	1.969	1-31/32	50.0	1.850	.004*	.139	+.006	.060	1.782		.125		48.0	2.61	2.50	37555	15300
SHR-200	2.000	2	50.8	1.880		.139	-.000	.060	1.840		.125		50.6	2.64	2.53	38570	17000

\* F.I.M.(FULL INDICATOR MOVEMENT)-MAXIMUM ALLOWABLE DEVIATION OF CONCENTRICITY BETWEEN GROOVE AND SHAFT.

† BASED ON HOUSINGS/SHAFTS MADE OF COLD ROLLED STEEL. FOR AN EXPLANATION OF FORMULAS USED TO DERIVE THRUST LOAD AND OTHER PERFORMANCE DATA, CONTACT THE ROTOR CLIP ENGINEERING DEPARTMENT.

\*\*\* FOR PLATED RINGS, ADD .002" TO THE LISTED MAXIMUM THICKNESS. MAXIMUM RING THICKNESS WILL BE A MINIMUM OF .0002" LESS THAN THE LISTED GROOVE WIDTH (W) MINIMUM.



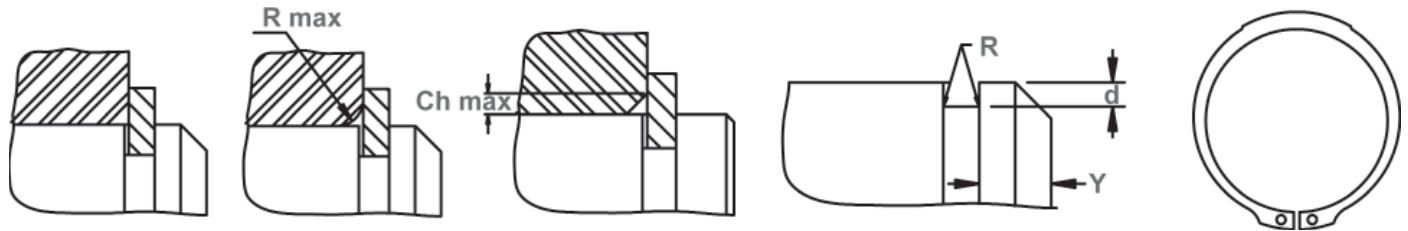

Square Corner Abutment

Maximum Corner Radius & Chamfer

Exploded Groove Profile & Edge Margin (Y) Maximum bottom radii (R), .005 for ring sizes -39 thru -98; -.010 for ring sizes -106 thru -200

Alternate Design (Manufacturer's Option)

RING NO.	LUG HEIGHT		MAXIMUM SECTION		MINIMUM SECTION		HOLE DIAMETER		GAGING DIA.	ALLOWABLE CORNER RADII & CHAMFERS			MAX LOAD w/ R max or Ch max (in lbs.)	EDGE MARGIN	R.P.M. LIMITS Standard material			
	H	Tol.	S max	Tol.	S min	Tol.	R	Tol.		Gd Max	R max	Ch max				P'r	Y	
SHR-39	.101	±.004	.068	±.004	.039	±.004	.042	+.010	.479	.047	.039	450	.039	80000				
SHR-42	.101		.076		.043		.042		.525	.057	.046	530	.039	72000				
SHR-47	.101		.088		.053		.042		.589	.070	.058	550	.045	69000				
SHR-50	.120		.090		.050		.050		.613	.070	.058	650	.048	65000				
SHR-59	.130	±.005	.102	±.005	.057	±.005	.050	-.002	.719	.070	.058	750	.054	52500				
SHR-62	.130		.106		.059		.050		.758	.074	.062	750	.057	49000				
SHR-66	.130		.112		.062		.050		.808	.077	.064	900	.060	45000				
SHR-75	.180		.127		.077		.078		.913	.089	.074	2500	.069	40500				
SHR-75	.180	±.006	.127	±.006	.077	±.006	.078	-.002	.949	.089	.074	2500	.072	38000				
SHR-87	.180		.148		.083		.078		1.056	.100	.083	2500	.081	34000				
SHR-98	.180		.151		.084		.078		1.164	.100	.083	2500	.090	30000				
SHR-98	.180		.151		.084		.078		1.177	.100	.083	2500	.093	30000				
SHR-106	.220	±.005	.161	±.007	.090	±.007	.093	+.015	1.256	.106	.088	4000	.096	27000				
SHR-112	.220		.169		.095		.093		1.329	.112	.093	4000	.099	26000				
SHR-118	.220		.176		.098		.093		1.391	.112	.093	4000	.105	24000				
SHR-118	.220		.176		.098		.093		1.391	.112	.093	4000	.114	24000				
SHR-125	.220		.185		.103		.093		1.468	.112	.093	4000	.114	23000				
SHR-131	.220		.192		.106		.093		1.538	.128	.107	4000	.117	21500				
SHR-137	.220		.200		.110		.093		1.607	.128	.107	4000	.126	20500				
SHR-137	.220		.200		.110		.093		1.607	.128	.107	4000	.132	20500				
SHR-150	.280		±.008		.218		±.008		.123	±.008	.109	-.002	1.752	.128	.107	5000	.141	18500
SHR-156	.280				.228				.127		.109		1.829	.128	.107	5000	.141	17000
SHR-156	.280	.228		.127	.109	1.841		.128	.107		5000		.144	17000				
SHR-175	.290	.254		.140	.109	2.050		.128	.107		5000		.150	15500				
SHR-175	.290	.254		.140	.109	2.069		.128	.107		5000		.156	15500				
SHR-193	.314	±.006		.280	±.006	.154		±.006	.125		-.002		2.265	.153	.128	6000	.168	14300
SHR-193	.314		.280	.154		.125	2.289		.153	.128		6000	.180	14100				
SHR-200	.314		.290	.160		.125	2.334		.153	.128		6000	.180	14000				

LARGER SIZES MAY BE AVAILABLE UPON REQUEST.

HARDNESS RANGES: STAINLESS STEEL RINGS (PH 15-7MO)

RING TYPE	SIZE RANGE	SCALE	ROCKWELL HARDNESS
SHR	39-42	30N	63-69.5
	47+	C	44-51

HARDNESS RANGES: BERYLLIUM COPPER RINGS

RING TYPE	SIZE RANGE	SCALE	ROCKWELL HARDNESS
SHR	39-42	30N	54-62
	47+	C	34-43

HARDNESS RANGES: CARBON STEEL RINGS (SAE 1060-1090)

RING TYPE	SIZE RANGE	SCALE	ROCKWELL HARDNESS
SHR	39-62	30N	67.5-72
	66+	C	47-52





# SHM Shaft Rings

## Axially Assembled, External Tamper-Proof

The SHM also functions like an SH retaining ring, but in "smaller" applications. It is also a tamper proof ring which does not have any lugs and can not be easily removed once installed.

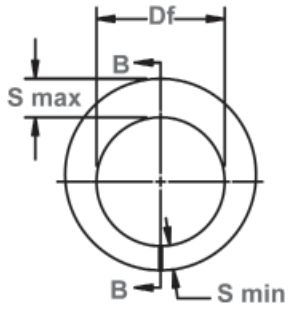

Free Diameter & Ring Measurements with Section B-B

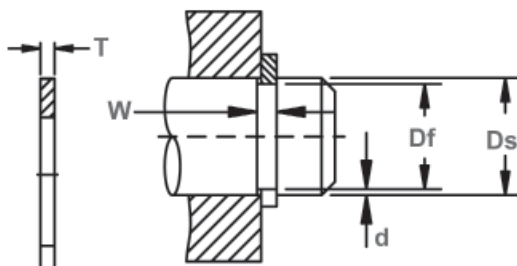

Shaft Diameter & Groove Dimensions

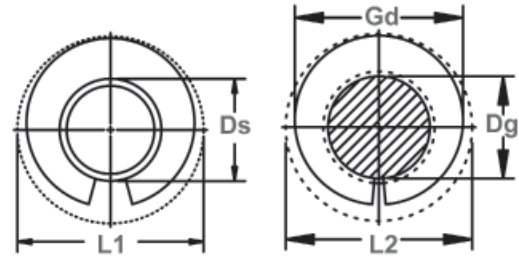

Clearance Diameter & Gaging Diameter

RING NO.	SHAFT DIAMETER inches			GROOVE SIZE					RING SIZE & WEIGHT					CLEARANCE DIA.			THRUST LD. (lbs.)	
				DIAMETER		WIDTH		DEPTH	FREE DIAMETER		THICKNESS***		Weight Per 1000 Pcs.	Expanded over shaft	Re-leased in groove	Sqr. Corner Abutment Groove w/90° wall		
	Ds DEC	Tol.	Ds FRACT	Dg	Tol.	W	Tol.	d	Df	Tol.	T	Tol.				lbs.	L1	L2
SHM-10	.101		-	.093	±.001	.024		.004	.090		.020		.036	.160	.152		30	
SHM-12	.125	±.001	1/8	.115	.0015*	.024	+.002	.005	.112		.020		.050	.186	.176		40	
SHM-13	.134		-	.124		.024	-.000	.005	.120	±.002	.020		.059	.197	.187		45	
SHM-15	.156		5/32	.144		.029		.006	.140		.025		.122	.252	.240	**	65	
SHM-18	.188		3/16	.174		.029		.007	.168		.025		.179	.297	.283	SEE NOTE	90	
SHM-20	.203		13/64	.189		.029		.007	.180		.025	±.002	.167	.302	.288	BELOW	100	
SHM-22	.219		7/32	.205		.039		.007	.200	±.003	.035		.334	.345	.331	**	110	
SHM-25	.250		1/4	.232	±.0015	.039		.009	.224		.035		.386	.384	.366		160	
SHM-26	.266		17/64	.248	+.002*	.039	+.003	.009	.240		.035		.467	.406	.388		170	
SHM-31	.312	±.0015	5/16	.292		.039	-.000	.010	.284		.035		.626	.478	.458		220	
SHM-32	.328		21/64	.308		.039		.010	.300		.035		.688	.498	.480		230	
SHM-37	.375		3/8	.351	±.002.002*	.046		.012	.340		.042		1.035	.567	.543		315	

\*F.I.M. (FULL INDICATOR MOVEMENT)-MAXIMUM ALLOWABLE DEVIATION OF CONCENTRICITY BETWEEN GROOVE AND SHAFT.  
 † BASED ON HOUSINGS/SHAFTS MADE OF COLD ROLLED STEEL. FOR AN EXPLANATION OF FORMULAS USED TO DERIVE THRUST LOAD AND OTHER PERFORMANCE DATA, CONTACT THE ROTOR CLIP ENGINEERING DEPT.  
 \*\*\*FOR PLATED RINGS, ADD .002" TO THE LISTED MAXIMUM THICKNESS. MAXIMUM RING THICKNESS WILL BE A MINIMUM OF .0002" LESS THAN THE LISTED GROOVE WIDTH (W) MINIMUM.  
 \*\*CALL FOR INFORMATION: +1 732-469-7333

## INSTALLATION OF ROTOR CLIP SHM RINGS

Rotor Clip SHM retaining rings can be installed by means of a tapered mandrel and a bushing. The mandrel can be eliminated in applications where the shaft can be easily tapered, as illustrated below.

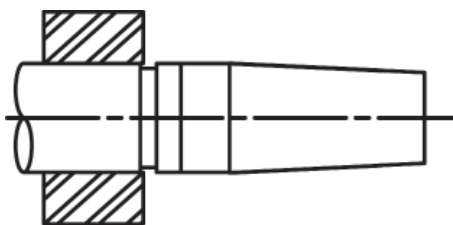

To install, place ring on mandrel and position bushing as shown. Ring can be pushed or tapped into groove.

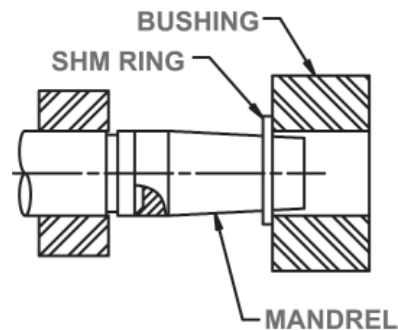

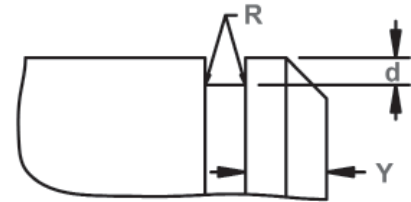
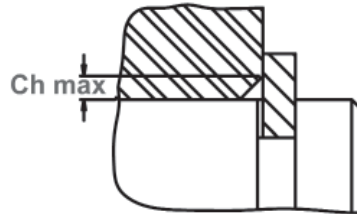
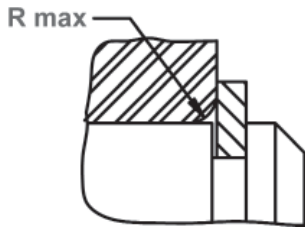

Maximum Corner Radius & Chamfer

Exploded Groove Profile & Edge Margin (Y)  
Maximum bottom radii (R). Sharp corners-  
no radii for ring sizes -10 thru -37.

RING NO.	S Max.	S Min.	GAGING DIA.	ALLOWABLE CORNER RADII &		MAX. LOAD w/ R max or Ch max. (in lbs.)	EDGE MARGIN	R.P.M. LIMITS Standard material	RING NO.	MANDREL					BUSHING		
	Ref.	Ref.		Gd Max	R max					Ch max	i P'r (lbs.)	Y	Dp	Tol.	W ref.	G	Tol.
SHM-10	.027	.017	.143	.013	.010	SEE NOTE ON PREVIOUS PAGE	.012	80000	SHM-10	.102		.036	.750		.104		3/8
SHM-12	.028	.018	.167	.013	.010		.015	80000	SHM-12	.126		.059	.750		.128		3/8
SHM-13	.029	.019	.178	.014	.011		.015	80000	SHM-13	.135		.069	.750		.137		3/8
SHM-15	.045	.027	.222	.021	.017		.018	80000	SHM-15	.157		.078	.875		.159		1/2
SHM-18	.052	.032	.264	.024	.019		.021	80000	SHM-18	.189		.110	.875		.191		1/2
SHM-20	.046	.030	.272	.023	.018		.021	80000	SHM-20	.204	+.000	.125	.875	±.005	.206	+.002	1/2
SHM-22	.058	.036	.308	.028	.022		.021	80000	SHM-22	.221	-.0015	.129	1.000		.223	-.000	1/2
SHM-25	.063	.037	.340	.028	.022		.027	80000	SHM-25	.252		.101	1.000		.254		5/8
SHM-26	.065	.037	.359	.027	.022		.027	80000	SHM-26	.268		.176	1.000		.270		5/8
SHM-31	.078	.050	.431	.038	.030		.030	80000	SHM-31	.314		.223	1.000		.316		5/8
SHM-32	.080	.050	.448	.038	.030		.030	80000	SHM-32	.330		.238	1.000		.332		5/8
SHM-37	.090	.058	.511	.042	.033		.036	80000	SHM-37	.377		.286	1.000		.379		5/8

LARGER SIZES MAY BE AVAILABLE UPON REQUEST.

HARDNESS RANGES: STAINLESS STEEL RINGS (PH 15-7MO)

RING TYPE	SIZE RANGE	SCALE	ROCKWELL HARDNESS
SHM	10-15	15N	82.5-86.0*
	18+	30N	63.0-69.5

\*HARDNESS CAN NOT BE CHECKED WITH ANY DEGREE OF ACCURACY DIRECTLY ON THESE RINGS.

HARDNESS RANGES: BERYLLIUM COPPER RINGS

RING TYPE	SIZE RANGE	SCALE	ROCKWELL HARDNESS
SHM	10-15	15N	77.0-82.0*
	18+	30N	54-62

\*HARDNESS CAN NOT BE CHECKED WITH ANY DEGREE OF ACCURACY DIRECTLY ON THESE RINGS.

HARDNESS RANGES: CARBON STEEL RINGS (SAE 1060-1090)

RING TYPE	SIZE RANGE	SCALE	ROCKWELL HARDNESS
SHM	10-15	15N	85.5-87.4*
	18+	30N	68.5-72

\*HARDNESS CAN NOT BE CHECKED WITH ANY DEGREE OF ACCURACY DIRECTLY ON THESE RINGS.

## PRODUCTION OF MANDREL AND BUSHING

Specifications for the production of a mandrel and bushing for installing SHM rings are listed in the above charts. Recommended material is high carbon spring steel, heat treated.

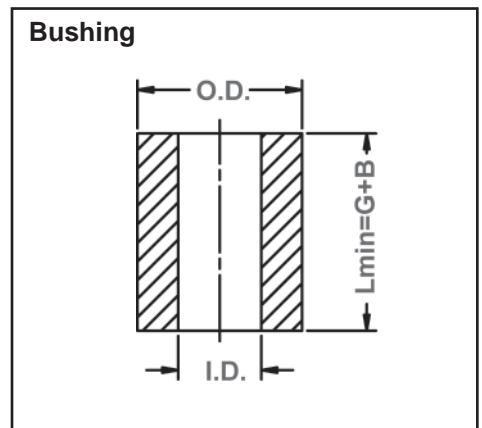
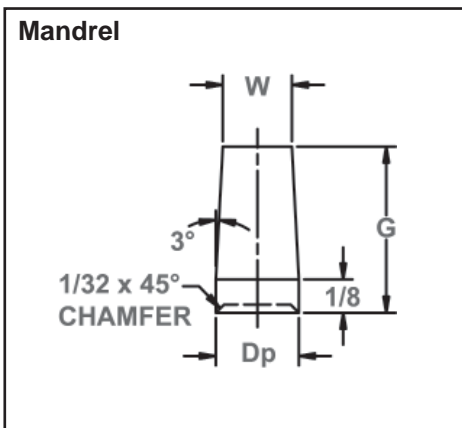
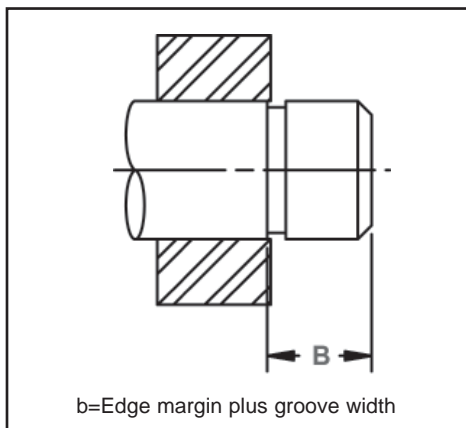



# BHO Housing Rings

## Axially Assembled, Internal Bowed

Compensating for accumulated tolerances is what a BHO retaining ring is designed to do in a housing/bore. Once snapped into the groove, bowed rings exert a force or "preload" on the retained parts for the range specified.

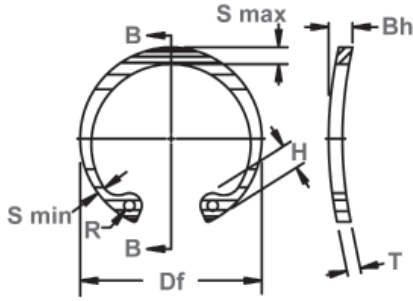

Free Diameter & Ring Measurements with Section B-B

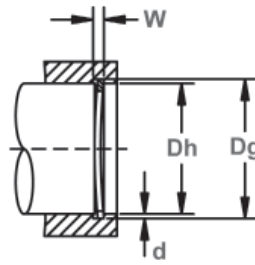

Housing Diameter & Groove Dimensions

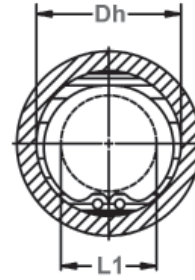

Clearance Diameter Compressed in Housing

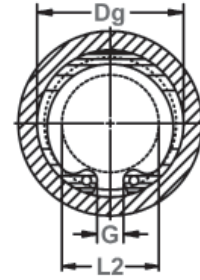

Clearance Diameter & Gap Width Released in Groove

RING NO.	HOUSING DIAMETER			GROOVE SIZE					RING SIZE & WEIGHT					CLEAR.DIA.			THRUST LD. (lbs.)		
				DIAMETER		WIDTH		DEPTH	FREE DIAMETER		THICKNESS***		BOW HEIGHT		Weight Per 1000 Pcs.	Compressed in housing	Released in groove	Sqr. Corner Abutment	
	Dh DEC	Dh FRACT	Dh mm	Dg	Tol.	W	Tol.	d	Df	Tol.	T	Tol.	Bh	Tol.				L1	L2
BHO-25	.250	1/4	6.4	.268	±.001	.030	+.002	.009	.280		.015		.036		.08	.115	.133	426	190
BHO-31	.312	5/16	7.9	.330	.0015*	.030	-.000	.009	.346		.015		.036		.11	.173	.191	538	240
BHO-37	.375	3/8	9.5	.397		.040		.011	.415		.025		.047		.25	.204	.226	1066	350
BHO-43	.438	7/16	11.1	.461	±.002	.040		.012	.482		.025		.047	±.006	.37	.23	.254	1238	440
BHO-45	.453	29/64	11.5	.477	.002*	.040		.012	.498		.025		.047		.43	.25	.274	1299	460
BHO-50	.500	1/2	12.7	.530		.055		.015	.548		.035		.063		.70	.26	.29	2010	510
BHO-51	.512	-	13.0	.542	±.002	.055	+.003	.015	.560		.035		.063	±.007	.77	.27	.30	2060	520
BHO-56	.562	9/16	14.3	.596	.004*	.055	-.000	.017	.620		.035		.063		.86	.275	.305	2253	710
BHO-62	.625	5/8	15.9	.665		.055		.020	.694		.035		.063		1.0	.34	.38	2507	1050
BHO-68	.688	11/16	17.5	.732		.055		.022	.763		.035		.063		1.2	.40	.44	2741	1280
BHO-75	.750	3/4	19.0	.796		.055		.023	.831		.035		.063		1.3	.45	.49	3045	1460
BHO-77	.777	-	19.7	.825		.062		.024	.859		.042		.073		1.7	.475	.52	4618	1580
BHO-81	.812	13/16	20.6	.862		.062		.025	.901		.042		.073		1.9	.49	.54	4872	1710
BHO-86	.866	-	22.0	.920		.062		.027	.961		.042		.073		2.0	.54	.59	5177	1980
BHO-87	.875	7/8	22.2	.931		.062		.028	.971		.042		.073		2.1	.545	.60	5227	2080
BHO-90	.901	-	22.9	.959	±.003	.062		.029	1.000	±.015	.042	±.002	.073	±.008	2.2	.565	.62	5430	2200
BHO-93	.938	15/16	23.8	1.000	.004*	.062		.031	1.041		.042		.073		2.4	.61	.67	5684	2450
BHO-100	1.000	1	25.4	1.066		.062		.033	1.111		.042		.073		2.7	.665	.73	6039	2800
BHO-102	1.023	-	26.0	1.091		.062		.034	1.136		.042		.073		2.8	.69	.755	6141	3000
BHO-106	1.062	1-1/16	27.0	1.130		.070		.034	1.180		.050		.085		3.7	.685	.75	7562	3050
BHO-112	1.125	1-1/8	28.6	1.197		.070		.036	1.249		.050		.085		4.0	.745	.815	8019	3400
BHO-118	1.181	-	30.0	1.255		.070		.037	1.319		.050		.085		4.3	.79	.86	8526	3700
BHO-118	1.188	1-3/16	30.2	1.262		.070		.037	1.319		.050		.085		4.3	.80	.87	8526	3700
BHO-125	1.250	1-1/4	31.7	1.330	±.004	.070		.040	1.388	±.025	.050		.085	±.012	4.8	.875	.955	8932	4250
BHO-125	1.259	-	32.0	1.339	.005*	.070		.040	1.388		.050		.085		4.8	.885	.965	8932	4250
BHO-131	1.312	1-5/16	33.3	1.396		.070		.042	1.456		.050		.085		5.0	.93	1.01	9440	4700
BHO-137	1.375	1-3/8	34.9	1.461		.070		.043	1.526		.050		.085		5.1	.99	1.07	9846	5050
BHO-137	1.378	-	35.0	1.464		.070		.043	1.526		.050		.085		5.1	.99	1.07	9846	5050
BHO-143	1.438	1-7/16	36.5	1.528		.070		.045	1.596		.050		.085		5.8	1.06	1.15	10353	5500
BHO-145	1.456	-	37.0	1.548		.070		.046	1.616		.050		.085		6.4	1.08	1.17	10455	5700
BHO-150	1.500	1-1/2	38.1	1.594		.070		.047	1.660		.050		.085		6.5	1.12	1.21	10708	6000
BHO-156	1.562	1-9/16	39.7	1.658		.100		.048	1.734		.062		.115		8.9	1.14	1.23	13906	6350
BHO-156	1.575	-	40.0	1.671	±.005	.100	+.005	.048	1.734	+.035	.062	±.003	.115	±.015	8.9	1.15	1.24	13906	6350
BHO-162	1.625	1-5/8	41.3	1.725	.005*	.100	-.000	.050	1.804	-.025	.062		.115		10.0	1.15	1.25	14413	6900
BHO-175	1.750	1-3/4	44.4	1.858		.100		.054	1.942		.062		.115		10.3	1.26	1.36	15580	8050

\*F.I.M. (FULL INDICATOR MOVEMENT)-MAXIMUM ALLOWABLE DEVIATION OF CONCENTRICITY BETWEEN GROOVE AND HOUSING.

† BASED ON HOUSINGS/SHAFTS MADE OF COLD ROLLED STEEL. FOR AN EXPLANATION OF FORMULAS USED TO DERIVE THRUST LOAD AND OTHER PERFORMANCE DATA, CONTACT THE ROTOR CLIP ENGINEERING DEPT.

\*\*\* FOR PLATED RINGS, ADD .002" TO THE LISTED MAXIMUM THICKNESS.

HARDNESS RANGES: STAINLESS STEEL RINGS (PH 15-7MO)

RING TYPE	SIZE RANGE	SCALE	ROCKWELL HARDNESS
BHO	25&31	15N	82.5-86
	37-102	30N	63-69.5
	106+	C	44-51



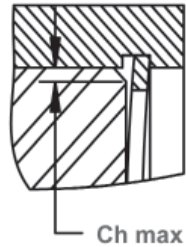
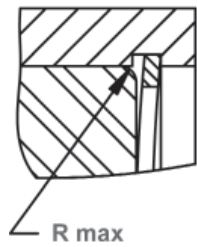

Maximum Corner Radius & Chamfer

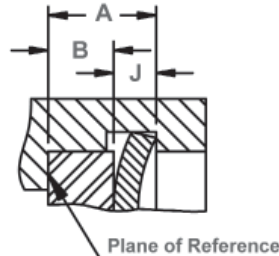

Outer Groove Location  
 $A \max = B \min + J \max$   
 $A \min = B \max + J \min$

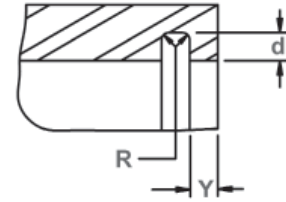

Exploded Groove Profile & Edge Margin (Y)  
 Maximum bottom radii (R), .005 for ring sizes -25 thru -100; .010 for ring sizes -102 and over

RING NO.	DISTANCE Outer groove wall to face of retained part		TAKE UP Resilient take up of tolerances of A&B	FORCE Needed to flatten rings	ALLOWABLE CORNER RADII & CHAMFERS		MAX LOAD w/ R max or Ch max (in lbs.)	EDGE MARGIN Y	LUG HEIGHT H	Tol.	MAXIMUM SECTION		MINIMUM SECTION		HOLE DIAMETER		GAP WIDTH Ring in groove G min.		
	J min	J max			J max-J min	lbs.					R max	Ch max	S max	Tol.	S min	Tol.		R	Tol.
BHO-25	.020	.028	.008	20	.011	.0085	190	.027	.065	±.003	.025	±.002	.015	±.002	.031	+.010 -.002	.047		
BHO-31	.020	.028		20	.016	.013	190	.027	.066		.033	±.003	.018	±.003	.029		±.003	.041	.055
BHO-37	.030	.038		45	.023	.018	530	.033	.082		.040		.028		.047			.063	
BHO-43	.030	.038		40	.027	.021	530	.036	.098		.049	.029	.041	.063					
BHO-45	.030	.038		40	.027	.021	530	.036	.098		.050	.030	.047	.071					
BHO-50	.042	.053		120	.027	.021	1100	.045	.114		.053	.035	.047	.090					
BHO-51	.042	.053		115	.027	.021	1100	.045	.114		.053	.035	.047	.092					
BHO-56	.042	.053		100	.027	.021	1100	.051	.132		.053	.035	.047	.095					
BHO-62	.042	.053		85	.027	.021	1100	.060	.132		.060	.035	.062	.104					
BHO-68	.042	.053		65	.027	.021	1100	.066	.132		.063	.036	.062	.118					
BHO-75	.042	.053	45	.032	.025	1100	.069	.142	.070	.040	.062	.143							
BHO-77	.049	.060	80	.035	.028	1650	.072	.146	.074	.044	.062	.145							
BHO-81	.049	.060	75	.035	.028	1650	.075	.155	.077	.044	.062	.153							
BHO-86	.049	.060	70	.035	.028	1650	.081	.155	.081	.045	.062	.172							
BHO-87	.049	.060	70	.035	.028	1650	.084	.155	.084	.045	.062	.179							
BHO-90	.049	.060	65	.038	.030	1650	.087	.155	.087	.047	.062	.188							
BHO-93	.049	.060	60	.038	.030	1650	.093	.155	.091	.050	.062	.200							
BHO-100	.049	.060	55	.042	.034	1650	.099	.155	.104	.052	.062	.212							
BHO-102	.049	.060	50	.042	.034	1650	.102	.155	.106	.054	.062	.220							
BHO-106	.057	.068	70	.044	.035	2400	.102	.180	.110	.055	.078	.213							
BHO-112	.057	.068	65	.047	.036	2400	.108	.180	.116	.057	.078	.232							
BHO-118	.057	.068	60	.047	.036	2400	.111	.180	.120	.058	.078	.226							
BHO-118	.057	.068	60	.047	.036	2400	.111	.180	.120	.058	.078	.245							
BHO-125	.057	.068	55	.048	.038	2400	.120	.180	.124	.062	.078	.265							
BHO-125	.057	.068	55	.048	.038	2400	.120	.180	.124	.062	.078	.290							
BHO-131	.057	.068	50	.048	.038	2400	.126	.180	.130	.062	.078	.284							
BHO-137	.057	.068	45	.048	.038	2400	.129	.180	.130	.063	.078	.297							
BHO-137	.057	.068	45	.048	.038	2400	.129	.180	.130	.063	.078	.305							
BHO-143	.057	.068	40	.048	.038	2400	.135	.180	.133	.065	.078	.313							
BHO-145	.057	.068	35	.048	.038	2400	.138	.180	.133	.065	.078	.320							
BHO-150	.057	.068	35	.048	.038	2400	.141	.180	.133	.066	.078	.340							
BHO-156	.075	.095	40	.064	.050	3900	.144	.202	.157	.078	.078	.338							
BHO-156	.075	.095	40	.064	.050	3900	.144	.202	.157	.078	.078	.374							
BHO-162	.075	.095	40	.064	.050	3900	.150	.227	.164	.082	.078	.339							
BHO-175	.075	.095	35	.064	.050	3900	.162	.234	.171	.083	.078	.372							

LARGER SIZES MAY BE AVAILABLE UPON REQUEST.

HARDNESS RANGES: CARBON STEEL RINGS (SAE 1060-1090)

RING TYPE	SIZE RANGE	SCALE	ROCKWELL HARDNESS
BHO	25&31	15N	86-88
	37-51	30N	69.5-73
	56-77	30N	67.5-72
	81-102	30N	66-71
	106+	C	47-52

HARDNESS RANGES: BERYLLIUM COPPER RINGS

RING TYPE	SIZE RANGE	SCALE	ROCKWELL HARDNESS
BHO	25&31	15N	77-82
	37-102	30N	54-62
	106+	C	34-43





# BSH Shaft Rings

**Axially Assembled, External Bowed**  
 Compensating for accumulated tolerances is what a BSH "bowed" retaining ring is designed to do on a shaft. Once snapped into the groove, bowed rings exert a force or a "preload" on the retained parts for the range specified.

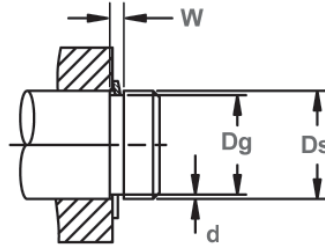
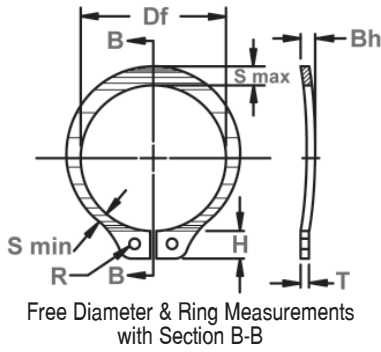

Shaft Diameter & Groove Dimensions

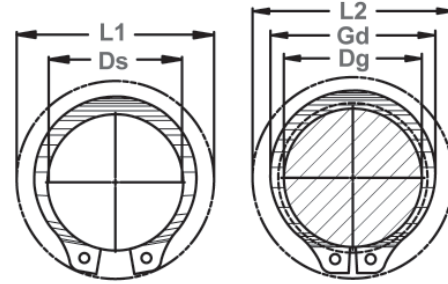

Clearance Diameter & Gaging Diameter

RING NO.	SHAFT DIAMETER			GROOVE SIZE			RING SIZE & WEIGHT					CLEAR. DIA.			THRUST LD. (lbs.)		
				Dg	DIAMETER		W	DEPTH	FREE DIAMETER		THICKNESS ***		BOW HEIGHT	Wght. Per 1000 Pcs.	Ex-panded over shaft	Re-leased in groove	Sqr. Corner Abutment
	Tol.	Tol.	d		Df	Tol.			Tol.	Bh	Tol.	Pr					Pg
BSH-25	.250	1/4	6.4	.230	±.0015	.040	.10	.225	+ .002	.025	.047	.21	.45	.43	599	175	
BSH-27	.276	-	7.0	.255	±.002 .002*	.040	.10	.250	+ .002 -.005	.025	.047	.23	.48	.46	660	195	
BSH-28	.281	9/32	7.1	.261		.040	.10	.256		.025	.047	.24	.49	.47	670	200	
BSH-31	.312	5/16	7.9	.290		.040	.11	.281		.025	.047	.27	.54	.52	751	240	
BSH-34	.344	11/32	8.7	.321		.040	.11	.309		.025	.047	.31	.57	.55	812	265	
BSH-35	.354	-	9.0	.330		.040	.12	.320		.025	.047	.35	.59	.57	832	300	
BSH-37	.375	3/8	9.5	.352		.040	.12	.338		.025	.047	.39	.61	.59	883	325	
BSH-39	.394	-	10.0	.369		.040	.12	.354		.025	.047	.42	.62	.60	954	335	
BSH-40	.406	13/32	10.3	.382		.040	.12	.366		.025	.047	.43	.63	.61	964	350	
BSH-43	.438	7/16	11.1	.412		.040	.13	.395		.025	.047	.50	.66	.64	1035	400	
BSH-46	.469	15/32	11.9	.443		.040	.13	.428		.025	.047	.54	.68	.66	1117	450	
BSH-50	.500	1/2	12.7	.468	±.002 .004*	.055	.16	.461	±.002 ±.005 -.010	.035	.063	.91	.77	.74	1675	550	
BSH-55	.551	-	14.0	.519	.055	.16	.509	.035		.063	.90	.81	.78	1827	600		
BSH-56	.562	9/16	14.3	.530	.055	.16	.521	.035		.063	1.1	.82	.79	1878	650		
BSH-59	.594	19/32	15.1	.559	.055	.17	.550	.035		.063	1.2	.86	.83	1979	750		
BSH-62	.625	5/8	15.9	.588	.055	.18	.579	.035		.063	1.3	.90	.87	2091	800		
BSH-66	.669	-	17.0	.629	.055	.20	.621	.035		.063	1.4	.93	.89	2233	950		
BSH-66	.672	43/64	17.1	.631	.055	.20	.621	.035		.063	1.4	.93	.89	2233	950		
BSH-68	.688	11/16	17.5	.646	±.003 .004*	.062	.21	.635		±.005 -.010	.042	.073	1.8	1.01	.97	3451	1000
BSH-75	.750	3/4	19.0	.704	.062	.23	.693	.042			.073	2.1	1.09	1.05	3756	1200	
BSH-78	.781	25/32	19.8	.733	.062	.24	.722	.042			.073	2.2	1.12	1.08	3959	1300	
BSH-81	.812	13/16	20.6	.762	.062	.25	.751	.042	.073		2.5	1.15	1.10	4060	1450		
BSH-87	.875	7/8	22.2	.821	.062	.27	.810	.042	.073		2.8	1.21	1.16	4365	1650		
BSH-93	.938	15/16	23.8	.882	.062	.28	.867	.042	.073		3.1	1.34	1.29	4720	1850		
BSH-98	.984	63/64	25.0	.926	.062	.29	.910	.042	.073		3.5	1.39	1.34	4923	2000		
BSH-100	1.000	1	25.4	.940	.062	.30	.925	.042	.073		3.6	1.41	1.35	5024	2100		
BSH-102	1.023	-	26.0	.961	.062	.31	.946	.042	.073		3.9	1.43	1.37	5126	2250		
BSH-106	1.062	1-1/16	27.0	.998	.070	.32	.982	.050	.085		4.8	1.50	1.44	6293	2400		
BSH-112	1.125	1-1/8	28.6	1.059	.070	.33	1.041	.050	.085	5.1	1.55	1.49	6699	2600			
BSH-118	1.188	1-3/16	30.2	1.118	.070	.35	1.098	.050	.085	5.6	1.61	1.54	7105	2950			
BSH-125	1.250	1-1/4	31.7	1.176	±.004 .005*	.070	.37	1.156	+ .010 -.015	.050	.085	5.9	1.69	1.62	7460	3250	
BSH-131	1.312	1-5/16	33.3	1.232	.070	.40	1.214	.050		.085	6.8	1.75	1.67	7866	3700		
BSH-137	1.375	1-3/8	34.9	1.291	.070	.42	1.272	.050		.085	7.2	1.80	1.72	8222	4100		
BSH-143	1.438	1-7/16	36.5	1.350	.070	.44	1.333	.050		.085	8.1	1.87	1.79	8628	4500		
BSH-150	1.500	1-1/2	38.1	1.406	.070	.47	1.387	.050		.085	9.0	1.99	1.90	8932	5000		
BSH-162	1.625	1-5/8	41.3	1.529	±.005 .005*	.096	.48	1.503		+ .013 -.020	.062	.115	13.2	2.17	2.08	12028	5500
BSH-175	1.750	1-3/4	44.4	1.650	.096	.50	1.618	.062			.115	15.3	2.31	2.21	12992	6200	

\*F.I.M. (FULL INDICATOR MOVEMENT)-MAXIMUM ALLOWABLE DEVIATION OF CONCENTRICITY BETWEEN GROOVE AND SHAFT.  
 † BASED ON HOUSINGS/SHAFTS MADE OF COLD ROLLED STEEL. FOR AN EXPLANATION OF FORMULAS USED TO DERIVE THRUST LOAD AND OTHER PERFORMANCE DATA, CONTACT THE ROTOR CLIP ENGINEERING DEPT.  
 \*\*\*FOR PLATED RINGS, ADD .002" TO THE LISTED MAXIMUM THICKNESS.

HARDNESS RANGES: STAINLESS STEEL RINGS (PH 15-7MO)

RING TYPE	SIZE RANGE	SCALE	ROCKWELL HARDNESS
BSH	25-81	30N	63-69.5
	87+	C	44-51



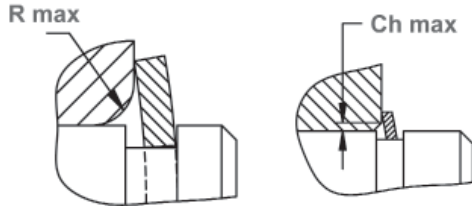

Maximum Corner Radius & Chamfer

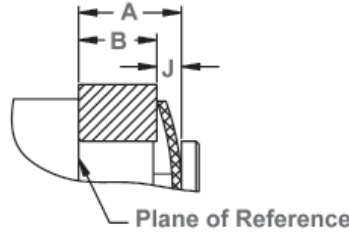

Outer Groove Location  
 $A \text{ max} = B \text{ min} + J \text{ max}$   
 $A \text{ min} = B \text{ max} + J \text{ min}$

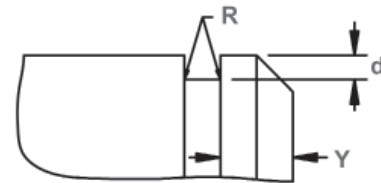

Exploded Groove Profile & Edge Margin (Y) Maximum bottom radii (R), square corners For ring sizes -25 thru -35; .005 For ring sizes -37 thru -100; .010 For ring sizes -102 and over.

RING NO.	DISTANCE Outer groove wall to face of retained part		TAKE-UP Resilient take-up of tolerances J max J min	FORCE Needed to flatten rings lbs.	ALLOWABLE CORNER RADII & CHAMFERS		MAX. LOAD w/ R max or Ch max (in lbs.) P <sub>r</sub> (lbs.)	EDGE MARGIN Y	LUG HEIGHT H Tol.	MAXIMUM SECTION		MINIMUM SECTION		HOLE DIAMETER		GAGGING DIA. Gd Max	R.P.M LIMITS Standard material						
	J min	J max			R max	Ch max				S max	Tol.	S min	Tol.	R	Tol.								
BSH-25	.030	.038	.008	50	.018	.011	470	.030	.080	±.003	.035	±.003	.025	±.003	.041	+.010	.290	80000					
BSH-27	.030	.038		50	.0175	.0105	470	.031	.081										.035	.024	.041	.315	76000
BSH-28	.030	.038		50	.020	.012	470	.030	.080										.038	.0255	.041	.326	74000
BSH-31	.030	.038		50	.020	.012	470	.033	.087										.040	.026	.041	.357	70000
BSH-34	.030	.038		45	.021	.0125	470	.033	.087										.042	.0265	.041	.390	64000
BSH-35	.030	.038		45	.023	.014	470	.036	.087										.046	.029	.041	.405	62000
BSH-37	.030	.038		45	.026	.0155	470	.036	.088										.050	.0305	.041	.433	60000
BSH-39	.030	.038		40	.027	.016	470	.037	.087										.052	.031	.041	.452	56500
BSH-40	.030	.038		40	.0285	.017	470	.036	.087										.054	.033	.041	.468	55000
BSH-43	.030	.038		35	.029	.0175	470	.039	.088										.055	.033	.041	.501	50000
BSH-46	.030	.038	35	.031	.018	470	.039	.088	.060	.035	.041	.540	42000										
BSH-50	.042	.053	.011	90	.034	.020	910	.048	.108	±.004	.065	±.004	.040	±.004	.047	+.015	.574	40000					
BSH-55	.042	.053		85	.027	.0165	910	.048	.108										.053	.036	.047	.611	36000
BSH-56	.042	.053		80	.038	.023	910	.048	.108										.072	.041	.047	.644	35000
BSH-59	.042	.053		70	.0395	.0235	910	.052	.109										.076	.043	.047	.680	32000
BSH-62	.042	.053		60	.0415	.025	910	.055	.110										.080	.045	.047	.715	30000
BSH-66	.042	.053		50	.040	.024	910	.060	.110										.082	.043	.047	.756	29000
BSH-66	.042	.053		50	.040	.024	910	.060	.110										.082	.043	.047	.758	29000
BSH-68	.049	.060		70	.042	.025	1340	.063	.136										.084	.048	.052	.779	28000
BSH-75	.049	.060		65	.046	.0275	1340	.069	.136										.092	.051	.052	.850	26500
BSH-78	.049	.060		60	.047	.028	1340	.072	.136										.094	.052	.052	.883	25500
BSH-81	.049	.060	55	.047	.028	1340	.075	.136	.096	.054	.052	.914	24500										
BSH-87	.049	.060	45	.051	.035	1340	.081	.137	.104	.057	.052	.987	23000										
BSH-93	.049	.060	40	.055	.033	1340	.084	.166	.110	.063	.078	1.054	21500										
BSH-98	.049	.060	40	.056	.0335	1340	.087	.167	.114	.0645	.078	1.106	20500										
BSH-100	.049	.060	35	.057	.034	1340	.090	.167	.116	.065	.078	1.122	20000										
BSH-102	.049	.060	35	.058	.035	1340	.093	.168	.118	.066	.078	1.147	19500										
BSH-106	.057	.068	60	.060	.036	1950	.096	.181	.122	.069	.078	1.192	19000										
BSH-112	.057	.068	55	.063	.038	1950	.099	.182	.128	.071	.078	1.261	18800										
BSH-118	.057	.068	50	.064	.0385	1950	.105	.182	.132	.072	.078	1.325	18000										
BSH-125	.057	.068	45	.068	.041	1950	.111	.183	.140	.076	.078	1.396	17000										
BSH-131	.057	.068	40	.068	.041	1950	.120	.183	.146	.0765	.078	1.458	16500										
BSH-137	.057	.068	35	.072	.043	1950	.126	.184	.152	.082	.078	1.529	16000										
BSH-143	.057	.068	30	.076	.045	1950	.132	.184	.160	.086	.078	1.600	15000										
BSH-150	.057	.068	30	.079	.047	1950	.141	.214	.168	.091	.120	1.668	14800										
BSH-162	.069	.094	.025	55	.087	.052	3000	.144	.235	.180	.097	.125	1.812	13200									
BSH-175	.069	.094		50	.091	.054	3000	.150	.237	.188	.101	.125	1.945	12200									

LARGER SIZES MAY BE AVAILABLE UPON REQUEST.

HARDNESS RANGES: CARBON STEEL RINGS (SAE 1060-1090)

RING TYPE	SIZE RANGE	SCALE	ROCKWELL HARDNESS
BSH	25-46	30N	69.5-73
	50-81	30N	66-71
	87-102	C	47-53
	106+	C	47-52

HARDNESS RANGES: BERYLLIUM COPPER RINGS

RING TYPE	SIZE RANGE	SCALE	ROCKWELL HARDNESS
BSH	18-23	15N	77-82*
	25-102	30N	54-62
	106+	C	34-43

\*HARDNESS CAN NOT BE CHECKED WITH ANY DEGREE OF ACCURACY DIRECTLY ON THESE RINGS.





# VHO Housing Rings

## Axially Assembled, Internal Beveled

These rings look exactly like their HO counterpart, only they have a 15° angle on the outer edge. This combines with a complementary groove angle to eliminate endplay by wedging itself between the groove and the retained part.

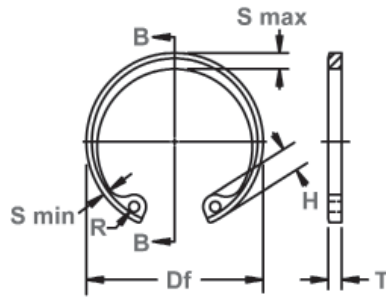

Free Diameter & Ring Measurements with Section B-B

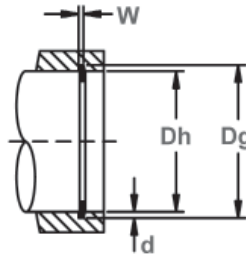

Housing Diameter & Groove Dimensions

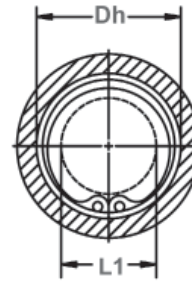

Clearance Diameter Compressed in Housing

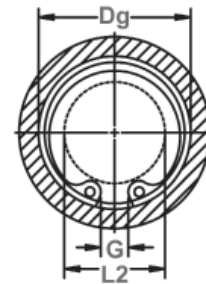

Clearance Diameter & Gap Width Released in Groove

RING NO.	HOUSING DIAMETER			GROOVE SIZE					RING SIZE & WEIGHT					CLEARANCE DIA.			
				DIAMETER		WIDTH		DEPTH	FREE DIAMETER			THICKNESS***		THICKNESS BEVELED END		Weight. Per 1000 Pcs.	Compressed in housing
	Dh DEC	Dh FRACT	Dh mm	Dg	Tol.	W	Tol.	d	Df	Tol.	T	Tol.	U	Tol.	lbs.		
VHO-100	1.000	1	25.4	1.076	+.003	.036		.038	1.111	+.015	.042		.033		2.7	.665	.70
VHO-102	1.023	-	26.0	1.101	-.000	.036		.039	1.136	-.010	.042		.033		2.8	.69	.725
VHO-106	1.062	1-1/16	27.0	1.138	.004*	.044		.038	1.180		.050		.041		3.7	.685	.72
VHO-112	1.125	1-1/8	28.6	1.205		.043		.040	1.249		.050		.040		4.0	.745	.78
VHO-118	1.181	-	30.0	1.265		.043		.042	1.319		.050		.040		4.3	.66	.69
VHO-118	1.188	1-3/16	30.2	1.272		.043		.042	1.319		.050		.040		4.3	.67	.70
VHO-125	1.250	1-1/4	31.7	1.342		.042		.046	1.388	+.025	.050	±.002	.039		4.8	.875	.92
VHO-125	1.259	-	32.0	1.351	+.004	.042		.046	1.388	-.020	.050		.039		4.8	.885	.93
VHO-131	1.312	1-5/16	33.3	1.408	-.000	.042		.048	1.456		.050		.039		5.0	.93	.97
VHO-137	1.375	1-3/8	34.9	1.475	.005*	.041		.050	1.526		.050		.038		5.1	.99	1.03
VHO-137	1.378	-	35.0	1.478		.041	+.005	.050	1.526		.050		.038	±.001	5.1	.99	1.03
VHO-143	1.438	1-7/16	36.5	1.542		.040	-.000	.052	1.596		.050		.037		5.8	1.06	1.11
VHO-145	1.456	-	37.0	1.562		.040		.053	1.616		.050		.037		6.4	1.08	1.13
VHO-150	1.500	1-1/2	38.1	1.604		.040		.052	1.660		.050		.037		6.5	1.12	1.17
VHO-156	1.562	1-9/16	39.7	1.674		.052		.056	1.734		.062		.048		8.9	1.10	1.15
VHO-156	1.575	-	40.0	1.687		.052		.056	1.734		.062		.048		8.9	1.11	1.16
VHO-162	1.625	1-5/8	41.3	1.743		.051		.059	1.804		.062		.047		10.0	1.16	1.22
VHO-165	1.653	-	42.0	1.773		.051		.060	1.835		.062		.047		10.4	1.17	1.22
VHO-168	1.688	1-11/16	42.9	1.810	+.005	.050		.061	1.874	+.035	.062		.046		10.8	1.21	1.27
VHO-175	1.750	1-3/4	44.4	1.878	-.000	.050		.064	1.942	-.025	.062		.046		10.3	1.27	1.32
VHO-181	1.812	1-13/16	46.0	1.944	.005*	.050		.066	2.012		.062	±.003	.046		11.5	1.34	1.40
VHO-185	1.850	-	47.0	1.984		.050		.067	2.054		.062		.046		12.8	1.36	1.43
VHO-185	1.875	1-7/8	47.6	2.011		.050		.068	2.054		.062		.046		12.8	1.38	1.45
VHO-193	1.938	1-15/16	49.2	2.082		.049		.072	2.141		.062		.045		13.3	1.46	1.53
VHO-200	2.000	2	50.8	2.144		.048		.072	2.210		.062		.044		14.0	1.52	1.59
VHO-206	2.047	-	52.0	2.195		.065		.074	2.280		.078		.060		18.0	1.52	1.59
VHO-206	2.062	2-1/16	52.4	2.210	+.006	.065	+.007	.074	2.280	+.040	.078		.060		18.0	1.54	1.61
VHO-212	2.125	2-1/8	54.0	2.279	-.000	.065	-.000	.077	2.350	-.030	.078		.060	±.0015	19.4	1.60	1.67
VHO-218	2.165	-	55.0	2.327	.006*	.064		.081	2.415		.078		.059		19.6	1.63	1.71
VHO-218	2.188	2-3/16	55.6	2.350		.064		.081	2.415		.078		.059		19.6	1.66	1.74

† BASED ON HOUSINGS/SHAFTS MADE OF COLD ROLLED STEEL.

NOTE: CONTACT ROTOR CLIP FOR AVAILABILITY OF SIZES LISTED.

\* F.I.M. (FULL INDICATOR MOVEMENT)- MAXIMUM ALLOWABLE DEVIATION OF CONCENTRICITY BETWEEN GROOVE AND HOUSING.

\*\*\*FOR PLATED RINGS ADD .002" TO THE LISTED MAXIMUM THICKNESS (T) AND BEVELED END THICKNESS (U) VALUES.



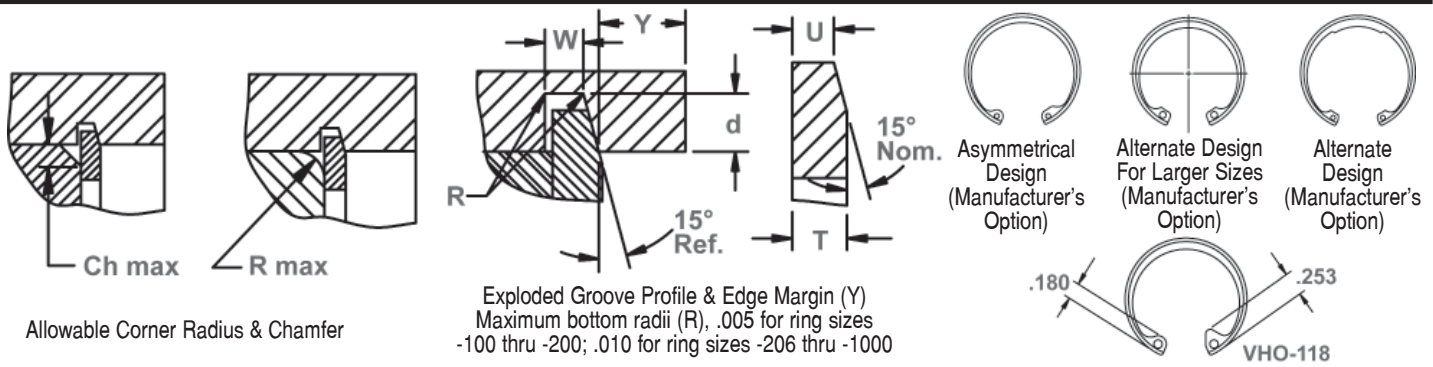

RING NO.	ALLOWABLE CORNER RADII & CHAMFERS		MAX. LOAD w/ R max or Ch max (in lbs.)	EDGE MARGIN	END-PLAY TAKE-UP	LUG HEIGHT		MAXIMUM SECTION		MINIMUM SECTION		HOLE DIAMETER		GAP WIDTH Ring in groove	THRUST LD. (lbs.) Sqr. corner abutment	
	R max	Ch max				Pr	Y	In.	H	Tol.	S max	Tol.	S min		Tol.	R
VHO-100	.042	.034	1650	.057	.005	.155		.104	±.005	.052	±.005	.062	+.010	.145	6039	1600
VHO-102	.042	.034	1650	.058	.005	.155		.106		.054		.062	-.002	.150	6141	1700
VHO-106	.044	.035	2400	.057	.005	.180		.110		.055		.078		.143	7562	1700
VHO-112	.047	.036	2400	.060	.005	.180		.116		.057		.078		.157	8019	1900
VHO-118	.047	.036	2400	.063	.0055	.180		.120		.058		.078		.150	8526	2100
VHO-118	.047	.036	2400	.063	.0055	.180		.120		.058		.078		.169	8526	2100
VHO-125	.048	.038	2400	.069	.006	.180		.124	±.006	.062	±.006	.078		.184	8932	2400
VHO-125	.048	.038	2400	.069	.006	.180		.124		.062		.078		.209	8932	2400
VHO-131	.048	.038	2400	.072	.006	.180		.130		.062		.078		.198	9440	2650
VHO-137	.048	.038	2400	.075	.0065	.180		.130		.063		.078		.211	9846	2900
VHO-137	.048	.038	2400	.075	.0065	.180		.130		.063		.078		.219	9846	2900
VHO-143	.048	.038	2400	.078	.007	.180		.133		.065		.078		.221	10353	3100
VHO-145	.048	.038	2400	.078	.007	.180		.133		.065		.078		.226	10455	3250
VHO-150	.048	.038	2400	.078	.007	.180	±.005	.133		.066		.078	+.015	.238	10708	3300
VHO-156	.064	.050	3900	.084	.0075	.202		.157		.078		.078	-.002	.238	13906	3600
VHO-156	.064	.050	3900	.084	.0075	.202		.157		.078		.078		.275	13906	3600
VHO-162	.064	.050	3900	.088	.008	.230		.164		.082		.078		.242	14413	4000
VHO-165	.064	.050	3900	.090	.008	.230		.167		.083		.078		.245	14718	4200
VHO-168	.064	.050	3900	.091	.008	.230		.170		.085		.078		.255	15022	4300
VHO-175	.064	.050	3900	.096	.0085	.230		.171		.083		.078		.267	15580	4700
VHO-181	.064	.050	3900	.099	.009	.230		.170	±.007	.084	±.007	.093		.277	16139	5050
VHO-185	.064	.050	3900	.100	.009	.234		.170		.085		.093		.245	16443	5200
VHO-185	.064	.050	3900	.102	.009	.234		.170		.085		.093		.310	16697	5400
VHO-193	.064	.050	3900	.108	.0095	.230		.170		.085		.093		.328	17255	5900
VHO-200	.064	.050	3900	.108	.0095	.230		.170		.085		.093		.332	17763	6100
VHO-206	.076	.061	6200	.111	.0095	.250		.186		.091		.093		.311	23091	6500
VHO-206	.078	.062	6200	.111	.0095	.250		.186		.091		.093		.349	23091	6500
VHO-212	.078	.062	6200	.115	.010	.250		.195		.096		.093		.345	23751	7000
VHO-218	.078	.062	6200	.121	.010	.250		.199		.098		.093		.323	24462	7450
VHO-218	.078	.062	6200	.121	.010	.250		.199		.098		.093		.373	24462	7450

FOR HARDNESS SPECIFICATIONS, SEE END OF THIS SECTION.

Note: Specifications listed within the catalog tables reflect Rotor Clip's standard commercial production dimensions. Published retaining ring standards including Military (MIL-DTL-21248D) / ASME / NAS / ANSI may require parts with alternative geometry. Please contact Rotor Clip Technical Sales Department to clarify conformance to specific requirements. (Tech@rotorclip.com or +1-732-469-7333.)



# VHO Housing Rings

## Axially Assembled, Internal Beveled

These rings look exactly like their HO counterpart, only they have a 15° angle on the outer edge. This combines with a complementary groove angle to eliminate endplay by wedging itself between the groove and the retained part.

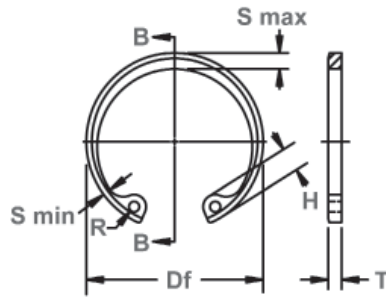

Free Diameter & Ring Measurements with Section B-B

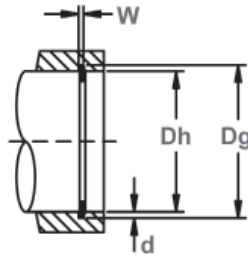

Housing Diameter & Groove Dimensions

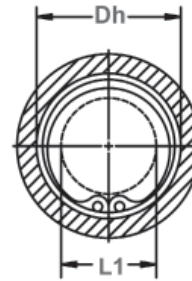

Clearance Diameter Compressed in Housing

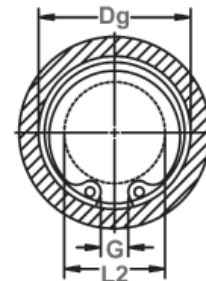

Clearance Diameter & Gap Width Released in Groove

RING NO.	HOUSING DIAMETER			GROOVE SIZE					RING SIZE & WEIGHT					CLEARANCE DIA.			
				DIAMETER		WIDTH		DEPTH	FREE DIAMETER	THICKNESS***		THICKNESS BEVELED END	Weight. Per 1000 Pcs.	Compressed in housing	Released in groove		
	Dh DEC	Dh FRACT	Dh mm	Dg	Tol.	W	Tol.	d	Df	Tol.	T	Tol.	U	Tol.	lbs.	L1	L2
VHO-225	2.250	2-1/4	57.1	2.420		.064		.085	2.490		.078		.059		21.8	1.67	1.75
VHO-231	2.312	2-5/16	58.7	2.484		.063		.086	2.560		.078		.058		22.6	1.73	1.80
VHO-237	2.375	2-3/8	60.3	2.552		.063		.089	2.630		.078		.058	±.0015	23.2	1.79	1.87
VHO-244	2.440	2-7/16	62.0	2.618		.062		.089	2.702		.078		.057		25.4	1.86	1.94
VHO-250	2.500	2-1/2	63.5	2.684		.062		.092	2.775		.078		.057		25.5	1.91	2.00
VHO-250	2.531	2-17/32	64.3	2.717		.062		.093	2.775		.078		.057		25.5	1.94	2.03
VHO-256	2.562	2-9/16	65.1	2.750		.078	+.007	.094	2.844	+.040	.093		.072		34.0	1.93	2.02
VHO-262	2.625	2-5/8	66.7	2.820		.077	-.000	.097	2.910	-.030	.093		.071		34.5	2.02	2.11
VHO-268	2.677	-	68.0	2.876		.077		.099	2.980		.093		.071		35.0	2.05	2.15
VHO-268	2.688	2-11/16	68.3	2.887		.077		.099	2.980		.093		.071		35.0	2.06	2.16
VHO-275	2.750	2-3/4	69.8	2.955		.076		.102	3.050		.093		.070	±.002	35.5	2.12	2.21
VHO-281	2.812	2-13/16	71.4	3.020		.076		.104	3.121		.093		.070		36.0	2.18	2.27
VHO-281	2.835	-	72.0	3.043	+.006	.076		.104	3.121		.093		.070		36.0	2.21	2.31
VHO-287	2.875	2-7/8	73.0	3.085	-.000	.076		.105	3.191		.093	±.003	.070		41.0	2.24	2.34
VHO-300	2.953	-	75.0	3.178	.006*	.074		.112	3.325		.093		.068		42.5	2.32	2.43
VHO-300	3.000	3	76.2	3.225		.074		.112	3.325		.093		.068		42.5	2.37	2.48
VHO-306	3.062	3-1/16	77.8	3.290		.089		.114	3.418		.109		.082		53.0	2.41	2.51
VHO-312	3.125	3-1/8	79.4	3.355		.089		.115	3.488		.109		.082		56.0	2.47	2.58
VHO-315	3.149	-	80.0	3.381		.089		.116	3.523		.109		.082		57.0	2.49	2.60
VHO-315	3.156	3-5/32	80.2	3.388		.089		.116	3.523		.109		.082		57.0	2.50	2.61
VHO-325	3.250	3-1/4	82.5	3.489		.089		.119	3.623	±.055	.109		.082		60.0	2.54	2.65
VHO-334SP1	3.346	3-11/32	85.0	3.591		.089	+.008	.122	3.734		.109		.082		65.0	2.63	2.74
VHO-347	3.469	3-15/32	88.1	3.726		.089	-.000	.128	3.857		.109		.082	±.0025	69.0	2.76	2.88
VHO-350	3.500	3-1/2	88.9	3.760		.089		.130	3.890		.109		.082		71.0	2.79	2.91
VHO-354SP1	3.543	-	90.0	3.806		.089		.132	3.936		.109		.082		72.0	2.83	2.95
VHO-354SP1	3.562	3-9/16	90.5	3.830		.089		.134	3.936		.109		.082		72.0	2.85	2.97
VHO-362	3.625	3-5/8	92.1	3.900		.089		.137	4.024		.109		.082		73.0	2.91	3.03
VHO-375	3.740	-	95.0	4.030		.089		.145	4.157		.109		.082		78.0	3.02	3.15
VHO-375	3.750	3-3/4	95.2	4.040		.089		.145	4.157		.109		.082		78.0	3.03	3.17
VHO-387	3.875	3-7/8	98.4	4.171		.089		.148	4.291	±.065	.109		.082		87.0	3.11	3.25
VHO-393	3.938	3-15/16	100.0	4.236		.089		.149	4.358		.109		.082		88.0	3.17	3.31
VHO-400	4.000	4	101.6	4.302		.089		.151	4.424		.109		.082		93.0	3.23	3.37

† BASED ON HOUSINGS/SHAFTS MADE OF COLD ROLLED STEEL.

NOTE: CONTACT ROTOR CLIP FOR AVAILABILITY OF SIZES LISTED.

\* F.I.M. (FULL INDICATOR MOVEMENT)- MAXIMUM ALLOWABLE DEVIATION OF CONCENTRICITY BETWEEN GROOVE AND HOUSING.

\*\*\*FOR PLATED RINGS ADD .002" TO THE LISTED MAXIMUM THICKNESS (T) AND BEVELED END THICKNESS (U) VALUES.

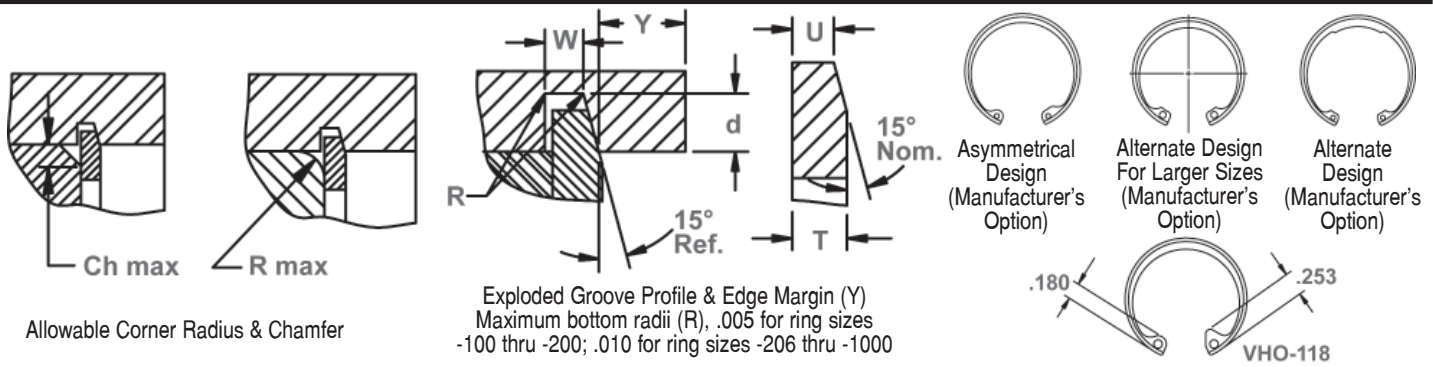

RING NO.	ALLOWABLE CORNER RADII & CHAMFERS		MAX. LOAD w/ R max or Ch max (in lbs.)	EDGE MARGIN	END-PLAY TAKE-UP	LUG HEIGHT		MAXIMUM SECTION		MINIMUM SECTION		HOLE DIAMETER		GAP WIDTH Ring in groove	THRUST LD. (lbs.) Sqr. corner abutment	
	R max	Ch max				P'r	Y	In.	H	Tol.	S max	Tol.	S min		Tol.	R
VHO-225	.078	.062	6200	.127	.0105	.280		.203		.099		.093		.368	25223	8050
VHO-231	.078	.062	6200	.129	.011	.280		.206		.100		.093		.362	25832	8400
VHO-237	.078	.062	6200	.133	.0115	.280		.207		.102		.093		.374	26542	8900
VHO-244	.078	.062	6200	.133	.012	.280		.209		.103		.110		.386	27304	9100
VHO-250	.078	.062	6200	.138	.012	.280		.210		.103		.110		.398	28014	9600
VHO-250	.078	.062	6200	.139	.0125	.280		.210		.103		.110		.460	28014	9600
VHO-256	.088	.070	9000	.141	.0125	.300	±.005	.222	±.007	.109	±.007	.110		.400	34206	10200
VHO-262	.088	.070	9000	.145	.013	.290		.226		.111		.110		.418	35068	10800
VHO-268	.090	.072	9000	.148	.013	.300		.230		.113		.110		.393	35931	11300
VHO-268	.090	.072	9000	.148	.013	.300		.230		.113		.110		.423	35931	11300
VHO-275	.092	.074	9000	.153	.014	.300		.234		.115		.110		.442	36642	11800
VHO-281	.088	.070	9000	.156	.014	.300		.230		.115		.110		.459	37504	12200
VHO-281	.088	.070	9000	.156	.014	.300		.230		.115		.110		.512	37504	12200
VHO-287	.092	.074	9000	.157	.014	.300		.240		.120		.110		.451	38367	12600
VHO-300	.092	.074	9000	.168	.015	.300		.250		.122		.110	+.015	.449	40093	14200
VHO-300	.092	.074	9000	.168	.015	.300		.250		.122		.110	-.002	.568	40093	14200
VHO-306	.097	.078	12000	.171	.015	.310		.254		.126		.125		.473	47807	14800
VHO-312	.099	.079	12000	.172	.0155	.310		.259		.129		.125		.469	48822	15200
VHO-315	.100	.080	12000	.174	.0155	.310		.262		.129		.125		.462	49329	15500
VHO-315	.100	.080	12000	.174	.0155	.310		.262		.129		.125		.481	49329	15500
VHO-325	.104	.083	12000	.178	.016	.342		.269		.135		.125		.509	50750	16400
VHO-334SP1	.108	.086	12000	.183	.0165	.342		.276		.140		.125		.514	52374	17300
VHO-347	.108	.086	12000	.192	.017	.342	±.008	.286	±.008	.144	±.008	.125		.571	54201	18800
VHO-350	.110	.088	12000	.195	.017	.342		.289		.142		.125		.574	54709	19300
VHO-354SP1	.110	.088	12000	.198	.0175	.342		.292		.142		.125		.586	55419	19800
VHO-354SP1	.110	.088	12000	.201	.018	.342		.292		.142		.125		.643	55419	19800
VHO-362	.116	.093	12000	.205	.018	.342		.299		.150		.125		.639	56739	21100
VHO-375	.120	.096	12000	.217	.0195	.342		.309		.155		.125		.647	58566	23100
VHO-375	.120	.096	12000	.217	.0195	.342		.309		.155		.125		.674	58566	23100
VHO-387	.123	.098	12000	.222	.020	.370		.319		.160		.125		.680	60494	24300
VHO-393	.124	.099	12000	.223	.020	.370		.324		.161		.125		.687	61611	24900
VHO-400	.128	.102	12000	.226	.020	.370		.330		.166		.125		.694	62626	25600

FOR HARDNESS SPECIFICATIONS, SEE END OF THIS SECTION.

Note: Specifications listed within the catalog tables reflect Rotor Clip's standard commercial production dimensions. Published retaining ring standards including Military (MIL-DTL-21248D) / ASME / NAS / ANSI may require parts with alternative geometry. Please contact Rotor Clip Technical Sales Department to clarify conformance to specific requirements. (Tech@rotorclip.com or +1-732-469-7333.)



# VHO Housing Rings

## Axially Assembled, Internal Beveled

These rings look exactly like their HO counterpart, only they have a 15° angle on the outer edge. This combines with a complementary groove angle to eliminate endplay by wedging itself between the groove and the retained part.

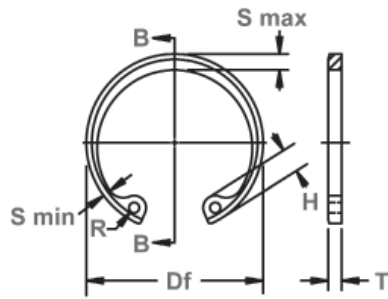

Free Diameter & Ring Measurements with Section B-B

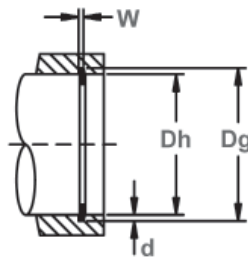

Housing Diameter & Groove Dimensions

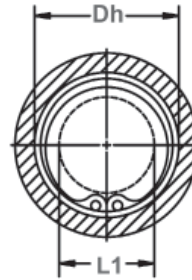

Clearance Diameter Compressed in Housing

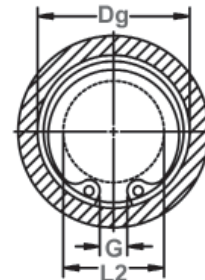

Clearance Diameter & Gap Width Released in Groove

RING NO.	HOUSING DIAMETER			GROOVE SIZE					RING SIZE & WEIGHT					CLEARANCE			
				DIAMETER		WIDTH		DEPTH	FREE DIAMETER		THICKNESS***		THICKNESS BEVELED END	Weight Per 1000 Pcs.	Compressed in housing	Released in groove	
	Dh DEC	Dh FRACT	Dh mm	Dg	Tol.	W	Tol.	d	Df	Tol.	T	Tol.	U				Tol.
VHO-412	4.125	4-1/8	104.8	4.433		.089		.154	4.558		.109		.082		97.0	3.36	3.51
VHO-425	4.250	4-1/4	108.0	4.562		.089		.156	4.691		.109		.082		101.0	3.48	3.63
VHO-433	4.331	-	110.0	4.647	+.006	.089	+.008	.158	4.756		.109		.082		105.0	3.50	3.65
VHO-450	4.500	4-1/2	114.3	4.824	-.000	.089	-.000	.162	4.940		.109	±.003	.082	±.0025	111.00	3.66	3.81
VHO-462	4.625	4-5/8	117.5	4.955	.006*	.089		.165	5.076		.109		.082		117.00	3.79	3.95
VHO-475	4.724	-	120.0	5.060		.089		.168	5.213		.109		.082		124.0	3.88	4.04
VHO-475	4.750	4-3/4	120.6	5.086		.089		.168	5.213	±.065	.109		.082		124.0	3.90	4.06
VHO-500	5.000	5	127.0	5.346		.089		.173	5.485		.109		.082		136.0	4.08	4.25
VHO-525	5.250	5-1/4	133.3	5.612		.102		.181	5.770		.125		.095		174.0	4.35	4.52
VHO-537	5.375	5-3/8	136.5	5.739	+.007	.102		.182	5.910		.125		.095		179.0	4.45	4.62
VHO-550	5.500	5-1/2	139.7	5.864	-.000	.102		.182	6.066		.125	±.004	.095		183.0	4.57	4.74
VHO-575	5.750	5-3/4	146.0	6.120	.006*	.102		.185	6.336		.125		.095		192.0	4.82	5.00
VHO-600	6.000	6	152.4	6.374		.102		.187	6.620		.125		.095		201.0	5.07	5.25
VHO-625	6.250	6-1/4	158.7	6.642		.129		.196	6.895		.156		.121		266.0	5.24	5.43
VHO-650	6.500	6-1/2	165.1	6.908		.129		.204	7.170		.156		.121		281.0	5.49	5.68
VHO-662	6.625	6-5/8	168.3	7.042		.129		.208	7.308	±.080	.156		.121		305.0	5.60	5.80
VHO-675	6.750	6-3/4	171.4	7.174		.128	+.010	.212	7.445		.156		.120		325.0	5.68	5.88
VHO-700	7.000	7	177.8	7.441		.128	-.000	.220	7.720		.156		.120		344.0	5.91	6.12
VHO-725	7.250	7-1/4	184.1	7.708	+.008	.159		.229	7.995		.187		.150	±.003	428.0	6.11	6.33
VHO-750	7.500	7-1/2	190.5	7.974	-.000	.159		.237	8.270		.187		.150		485.0	6.36	6.59
VHO-775	7.750	7-3/4	196.8	8.240	.006	.159		.245	8.545		.187	±.005	.150		520.0	6.58	6.82
VHO-800	8.000	8	203.2	8.507		.155		.253	8.820		.187		.146		555.0	6.83	7.07
VHO-825	8.250	8-1/4	209.5	8.773		.155		.261	9.095		.187		.146		603.0	7.04	7.29
VHO-850	8.500	8-1/2	215.9	9.040		.151		.270	9.285	±.090	.187		.142		634.0	7.29	7.55
VHO-875	8.750	8-3/4	222.2	9.307		.151		.278	9.558		.187		.142		653.0	7.38	7.65
VHO-900	9.000	9	228.6	9.573		.151		.286	9.830		.187		.142		732.0	7.63	7.91
VHO-925	9.250	9-1/4	235.0	9.838		.151		.294	10.102		.187		.142		767.0	7.88	8.16
VHO-950	9.500	9-1/2	241.3	10.106		.147		.303	10.375		.187		.138		803.0	7.98	8.27
VHO-975	9.750	9-3/4	247.7	10.372		.147		.311	10.648		.187		.138		833.0	8.23	8.52
VHO-1000	10.000	10	254.0	10.639		.147		.319	10.920		.187		.138		863.0	8.48	8.78

† BASED ON HOUSINGS/SHAFTS MADE OF COLD ROLLED STEEL.

NOTE: CONTACT ROTOR CLIP FOR AVAILABILITY OF SIZES LISTED.

\* F.I.M. (FULL INDICATOR MOVEMENT)- MAXIMUM ALLOWABLE DEVIATION OF CONCENTRICITY BETWEEN GROOVE AND HOUSING.

\*\*\*FOR PLATED RINGS ADD .002" TO THE LISTED MAXIMUM THICKNESS (T) AND BEVELED END THICKNESS (U) VALUES.

HARDNESS RANGES: STAINLESS STEEL RINGS (PH 15-7MO)

RING TYPE	SIZE RANGE	SCALE	ROCKWELL HARDNESS
VHO	100&102	30N	63-69.5
	106+	C	44-51



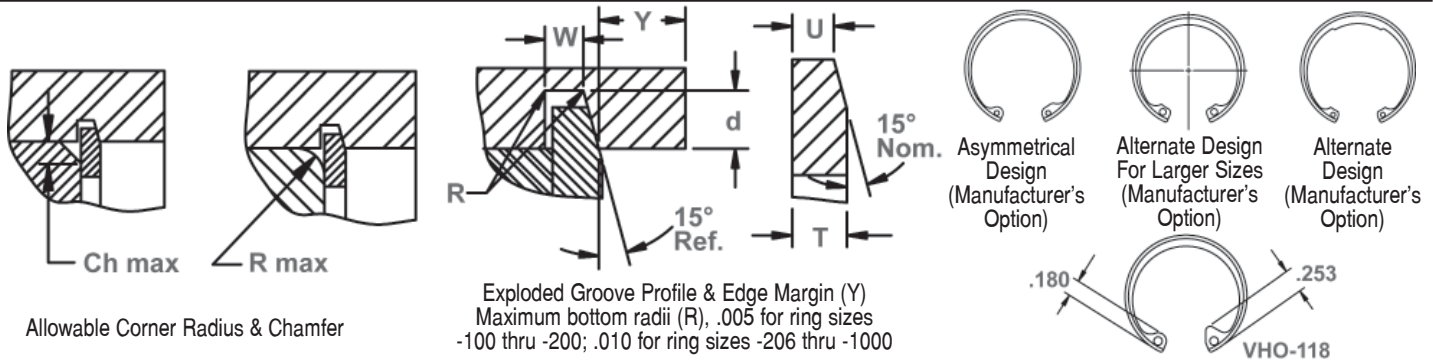

RING NO.	ALLOWABLE CORNER RADII & CHAMFERS		MAX. LOAD w/ R max or Ch max (in lbs.)	EDGE MARGIN	END-PLAY TAKE-UP	LUG HEIGHT		MAXIMUM SECTION		MINIMUM SECTION		HOLE DIAMETER		GAP WIDTH Ring in groove	THRUST LD. (lbs.)	
	R max	Ch max				P'r	Y	In.	H	Tol.	S max	Tol.	S min		Tol.	R
VHO-412	.130	.104	12000	.231	.021	.370		.330		.171		.125	+.015	.718	64554	26900
VHO-425	.138	.110	12000	.234	.021	.370		.335		.180		.125	-.002	.743	66483	28100
VHO-433	.142	.114	12000	.237	.021	.405		.343		.180		.156		.803	67599	29000
VHO-450	.146	.117	12000	.243	.022	.405	±.008	.351		.181		.156		.787	70340	30900
VHO-462	.151	.121	12000	.247	.022	.405		.405		.183		.156		.822	72370	32400
VHO-475	.154	.123	12000	.252	.023	.405		.370		.183		.156		.773	74298	33800
VHO-475	.154	.123	12000	.252	.023	.405		.370		.183		.156		.843	74298	33800
VHO-500	.158	.126	12000	.259	.023	.435		.435		.186		.156		.753	78155	38700
VHO-525	.168	.134	15000	.271	.024	.435		.435		.198		.156		.886	94091	40300
VHO-537	.168	.134	15000	.273	.024	.435		.435	±.009	.198	±.009	.156		.893	96324	41500
VHO-550	.168	.134	15000	.273	.024	.435		.435		.198		.156		.879	98658	42500
VHO-575	.168	.134	15000	.277	.025	.435		.435		.198		.156		.905	103124	45100
VHO-600	.168	.134	15000	.280	.025	.435		.435		.198		.156		.929	107489	47600
VHO-625	.177	.142	23000	.294	.026	.485		.485		.211		.187	+.020	.956	139766	52000
VHO-650	.181	.145	23000	.306	.027	.485		.485		.219		.187	-.005	1.040	145450	56200
VHO-662	.183	.146	23000	.312	.028	.485		.485		.221		.187		1.063	148190	58400
VHO-675	.188	.150	23000	.318	.028	.515		.515		.224		.187		.985	151032	60700
VHO-700	.196	.157	23000	.330	.029	.515	±.010	.515		.232		.187		1.037	156615	65300
VHO-725	.202	.162	34000	.343	.031	.545		.545		.238		.187		1.085	194373	70400
VHO-750	.208	.166	34000	.355	.032	.545		.545		.247		.187		1.138	201173	75400
VHO-775	.214	.171	34000	.367	.033	.560		.560		.255		.187		1.178	207872	80500
VHO-800	.220	.176	34000	.379	.034	.560		.560		.262		.187		1.238	214571	85800
VHO-825	.229	.183	34000	.391	.035	.580		.580	±.010	.270	±.010	.187		1.269	221270	91300
VHO-850	.235	.188	34000	.405	.036	.580		.580		.277		.187		1.444	227969	97300
VHO-875	.241	.193	34000	.417	.037	.660		.591		.286		.187		1.481	233856	103200
VHO-900	.249	.199	34000	.429	.038	.660		.609		.294		.187		1.539	241367	109200
VHO-925	.253	.202	34000	.441	.039	.660		.625		.299		.187		1.559	248066	115300
VHO-950	.258	.206	34000	.454	.041	.735		.642		.304		.187		1.596	254765	122100
VHO-975	.263	.210	34000	.466	.042	.735		.658		.309		.187		1.680	261464	128600
VHO-1000	.270	.216	34000	.478	.043	.735		.675		.315		.187		1.687	268163	135300

Note: Specifications listed within the catalog tables reflect Rotor Clip's standard commercial production dimensions. Published retaining ring standards including Military (MIL-DTL-21248D) / ASME / NAS / ANSI may require parts with alternative geometry. Please contact Rotor Clip Technical Sales Department to clarify conformance to specific requirements. (Tech@rotorclip.com or +1-732-469-7333.)

HARDNESS RANGES: CARBON STEEL RINGS (SAE 1060-1090)

RING TYPE	SIZE RANGE	SCALE	ROCKWELL HARDNESS
VHO	100&102	30N	66-71
	106-347	C	47-52
	350-700	C	44-51
	725-1000	C	40-47

HARDNESS RANGES: BERYLLIUM COPPER RINGS

RING TYPE	SIZE RANGE	SCALE	ROCKWELL HARDNESS
VHO	100&102	30N	54-62
	106+	C	34-43





# VSH Shaft Rings

## Axially Assembled, External Beveled

These rings look exactly like their SH counterpart, only they have a 15° angle on the inner edge. This combines with a complimentary groove angle to eliminate endplay by wedging itself between the groove and the retained part.

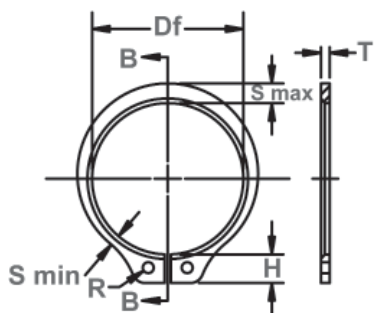

Free Diameter & Ring Measurements with Section B-B

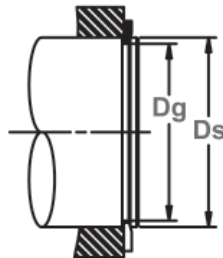

Shaft Diameter & Groove Dimensions

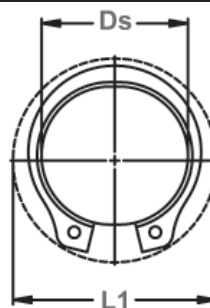

Clearance Diameter Expanded Over Shaft



Clearance Diameter & Gaging Diameter Released in Groove

RING NO.	SHAFT DIAMETER			GROOVE SIZE			RING SIZE & WEIGHT						CLEARANCE DIA.	
				DIAMETER	WIDTH	DEPTH	FREE DIAMETER	THICKNESS***	THICKNESS BEVELED END	WEIGHT PER 1000 PCS.	EX-PANDED OVER SHAFT	RE-LEASED IN GROOVE		
	Ds DEC	Ds FRACT	Ds mm	Dg	Tol.	W Tol.	d	Df	Tol.	T Tol.	U Tol.	lbs.	L1	L2
VSH-100	1.000	1	25.4	.930	+ .000	.037	.035	.925	+ .005	.042	.034	3.6	1.41	1.38
VSH-102	1.023	-	26.0	.951	-.003 .004*	.036	.036	.946	-.010	.042	.033	3.9	1.43	1.40
VSH-106	1.062	1-1/16	27.0	.992		.044	.035	.982		.050	.041	4.8	1.50	1.47
VSH-112	1.125	1-1/8	28.6	1.051		.044	.037	1.041		.050	.041	5.1	1.55	1.52
VSH-119	1.188	1-3/16	30.2	1.108	+ .000	.044	.040	1.098	+ .010	.050	.041	5.6	1.61	1.57
VSH-125	1.250	1-1/4	31.7	1.166	-.004	.043	.042	1.156	-.015	.050	.040	5.9	1.69	1.65
VSH-131	1.312	1-5/16	33.3	1.224	.005*	.042	.044	1.214		.050	.039	6.8	1.75	1.71
VSH-137	1.375	1-3/8	34.9	1.282		.042	.046	1.272		.050	.039	7.2	1.80	1.76
VSH-143	1.438	1-7/16	36.5	1.343		.042	.047	1.333		.050	.039	8.1	1.87	1.83
VSH-150	1.500	1-1/2	38.1	1.397		.041	.051	1.387		.050	.038	9.0	1.99	1.95
VSH-157	1.562	1-9/16	39.7	1.459		.053	.051	1.446		.062	.049	12.4	2.10	2.05
VSH-162	1.625	1-5/8	41.3	1.516		.053	.054	1.503		.062	.049	13.2	2.17	2.13
VSH-168	1.688	1-11/16	42.9	1.573		.052	.057	1.560		.062	.048	14.8	2.24	2.20
VSH-175	1.750	1-3/4	44.4	1.631	+ .000	.052	.059	1.618	+ .013	.062	.048	15.3	2.31	2.26
VSH-177	1.772	-	45.0	1.650	-.005	.052	.061	1.637	-.020	.062	.048	15.4	2.33	2.28
VSH-181	1.812	1-13/16	46.0	1.688	.005*	.052	.062	1.675		.062	.048	16.2	2.38	2.33
VSH-187	1.875	1-7/8	47.6	1.748		.052	.063	1.735		.062	.048	17.3	2.44	2.39
VSH-196	1.969	1-31/32	50.0	1.832		.051	.068	1.819		.062	.047	18.0	3.09	2.54
VSH-200	2.000	2	50.8	1.863		.051	.068	1.850		.062	.047	19.0	3.10	2.57
VSH-206	2.062	2-1/16	52.4	1.921		.067	.070	1.906		.078	.062	25.0	3.22	2.68
VSH-212	2.125	2-1/8	54.0	1.979		.067	.073	1.964		.078	.062	26.1	3.29	2.78
VSH-215	2.156	2-5/32	54.8	2.008		.067	.074	1.993		.078	.062	26.3	3.40	2.81
VSH-225	2.250	2-1/4	57.1	2.096		.066	.077	2.081	+ .015	.078	.061	27.7	3.51	2.90
VSH-231	2.312	2-5/16	58.7	2.154		.065	.079	2.139	-.025	.078	.060	28.0	3.58	2.97
VSH-237	2.375	2-3/8	60.3	2.212		.065	.081	2.197		.078	.060	29.2	3.50	3.06
VSH-243	2.438	2-7/16	61.9	2.270	+ .000	.065	.084	2.255		.078	.060	29.5	3.64	3.07
VSH-250	2.500	2-1/2	63.5	2.328	-.006	.064	.086	2.313		.078	.059	29.7	3.17	3.09
VSH-255	2.559	-	65.0	2.397	.006*	.064	.081	2.377		.078	.059	33.9	3.18	3.10
VSH-262	2.625	2-5/8	66.7	2.448		.064	.088	2.428		.078	.059	35.0	3.30	3.22
VSH-268	2.688	2-11/16	68.3	2.505		.064	.091	2.485		.078	.059	36.0	3.37	3.29
VSH-275	2.750	2-3/4	69.8	2.563		.079	.093	2.543	+ .020	.093	.073	47.0	3.48	3.40
VSH-287	2.875	2-7/8	73.0	2.679		.078	.098	2.659	-.030	.093	.072	48.5	3.60	3.51
VSH-293	2.938	2-15/16	74.6	2.737		.078	.100	2.717		.093	.072	50.0	3.67	3.58
VSH-300	3.000	3	76.2	2.795		.077	.102	2.775		.093	.071	52.0	3.60	3.50
VSH-306	3.062	3-1/16	77.8	2.852		.077	.105	2.832		.093	.071	47.0	3.74	3.64

\*\*\* FOR PLATED RINGS, ADD .002" TO THE LISTED MAXIMUM THICKNESS (T) AND BEVELED END THICKNESS (U) VALUES.

\* F.I.M. (FULL INDICATOR MOVEMENT)-MAXIMUM ALLOWABLE DEVIATION OF CONCENTRICITY BETWEEN GROOVE AND SHAFT. FOR HARDNESS SPECIFICATIONS, SEE END OF THIS SECTION.



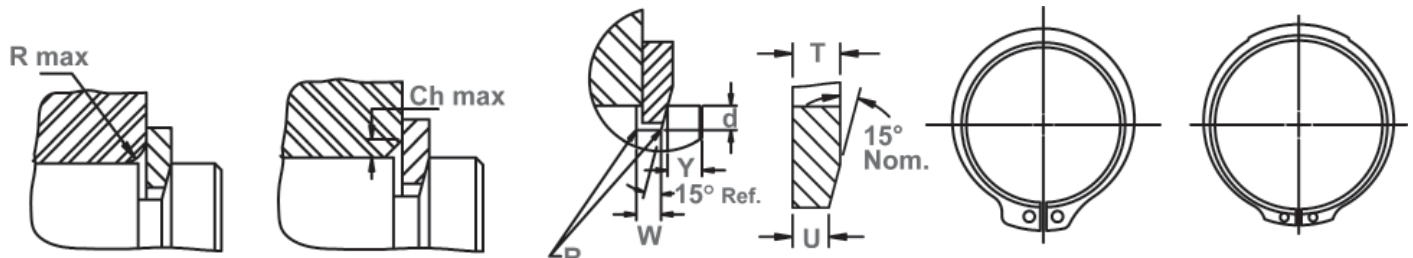

Maximum Corner Radius & Chamfer

Exploded Groove Profile & Edge Margin  
Maximum bottom radii (R), .005 for ring sizes -100 thru -200; .010 for ring sizes -206 thru -1000

Asymmetrical Design  
Manufacturer's Option

Alternate Lug Design  
Manufacturer's Option  
For Larger Sizes

RING NO.	ALLOWABLE CORNER RADII & CHAMFERS		MAX LOAD W/ R MAX OR CH MAX (IN LBS.)	EDGE MARGIN	END PLAY TAKE-UP	LUG HEIGHT		MAXIMUM SECTION		MINIMUM SECTION		HOLE DIAMETER		GAGING DIA.	THRUST LOAD (lbs.) SQR. CORNER ABUTMENT	
	R max	Ch max				P'r	Y	In.	H	Tol.	S max	Tol.	S min		Tol.	R
VSH-100	.057	.034	1340	.052	.005	.167		.116	±.005	.065	±.005	.078		1.144	5024	1200
VSH-102	.058	.035	1340	.054	.005	.168		.118		.066		.078		1.170	5126	1300
VSH-106	.060	.036	1950	.052	.005	.181		.122		.069		.078		1.217	6293	1300
VSH-112	.063	.038	1950	.055	.005	.182		.128		.071		.078		1.286	6699	1450
VSH-119	.064	.0385	1950	.060	.005	.198		.132		.072		.078		1.351	7105	1650
VSH-125	.068	.041	1950	.063	.0055	.183		.140		.076		.078		1.424	7460	1850
VSH-131	.068	.041	1950	.066	.006	.183		.146		.0765		.078		1.490	7866	2000
VSH-137	.072	.043	1950	.069	.006	.184		.152		.082		.078		1.562	8222	2250
VSH-143	.076	.045	1950	.070	.006	.184	±.004	.160	±.006	.086	±.006	.078		1.636	8628	2450
VSH-150	.079	.047	1950	.076	.007	.214		.168		.091		.120		1.706	8932	2700
VSH-157	.082	.049	3000	.076	.007	.255		.172		.093		.125		1.778	11571	2900
VSH-162	.087	.052	3000	.081	.0075	.235		.180		.097		.125		1.849	12028	3100
VSH-168	.090	.054	3000	.085	.0075	.235		.184		.099		.125		1.912	12535	3400
VSH-175	.091	.054	3000	.088	.008	.260	±.005	.188		.101		.125		1.981	12992	3650
VSH-177	.092	.055	3000	.090	.008	.237		.190		.102		.125		2.004	13144	3750
VSH-181	.092	.055	3000	.093	.008	.238		.192		.102		.125	+ .015	2.047	13449	3950
VSH-187	.094	.056	3000	.094	.0085	.239		.196		.104		.125	- .002	2.114	13906	4200
VSH-196	.094	.056	3000	.102	.009	.245		.200		.106		.125		2.209	14565	4700
VSH-200	.096	.057	3000	.102	.009	.239		.204		.108		.125		2.246	14819	4800
VSH-206	.098	.059	5000	.105	.0095	.266		.208		.111		.125		2.315	19234	5100
VSH-212	.098	.059	5000	.109	.010	.280		.212		.113		.125		2.386	19793	5450
VSH-215	.097	.058	5000	.111	.010	.280		.212		.113		.125		2.410	20097	5600
VSH-225	.100	.060	5000	.115	.010	.280		.220		.116		.125		2.513	21011	6100
VSH-231	.100	.060	5000	.118	.0105	.280		.222		.118		.125		2.577	21518	6300
VSH-237	.100	.060	5000	.121	.011	.292		.224		.119		.125		2.640	22127	6800
VSH-243	.102	.061	5000	.126	.011	.268		.228		.120		.125		2.706	22736	7100
VSH-250	.104	.062	5000	.129	.0115	.292	±.005	.232	±.007	.122	±.007	.125		2.772	23345	7500
VSH-255	.108	.065	5000	.121	.011	.268		.238		.125		.125		2.845	23853	7300
VSH-262	.1095	.066	5000	.132	.0115	.292		.242		.127		.125		2.910	24462	8200
VSH-268	.1115	.067	5000	.136	.012	.292		.246		.129		.125		2.975	25071	8600
VSH-275	.112	.067	7350	.139	.012	.324		.248		.131		.125		3.041	30552	9000
VSH-287	.115	.069	7350	.147	.013	.324		.256		.133		.125		3.172	31973	9900
VSH-293	.116	.070	7350	.150	.0135	.324		.260		.136		.125		3.239	32683	10300
VSH-300	.117	.070	7350	.153	.0135	.264		.264		.138		.125		3.306	33394	10700
VSH-306	.107	.064	7350	.157	.014	.300		.300		.131		.125		3.347	34003	11200

† BASED ON HOUSINGS/SHAFTS MADE OF COLD ROLLED STEEL. FOR AN EXPLANATION OF FORMULAS USED TO DERIVE THRUST LOAD AND OTHER PERFORMANCE DATA, CONTACT THE ROTOR CLIP ENGINEERING DEPARTMENT. FOR HARDNESS SPECIFICATIONS, SEE END OF THIS SECTION.

Note: Specifications listed within the catalog tables reflect Rotor Clip's standard commercial production dimensions. Published retaining ring standards including Military (MIL-DTL-21248D) / ASME / NAS / ANSI may require parts with alternative geometry. Please contact Rotor Clip Technical Sales Department to clarify conformance to specific requirements. (Tech@rotorclip.com or +1-732-469-7333.)





# VSH Shaft Rings

## Axially Assembled, External Beveled

These rings look exactly like their SH counterpart, only they have a 15° angle on the inner edge. This combines with a complimentary groove angle to eliminate endplay by wedging itself between the groove and the retained part.

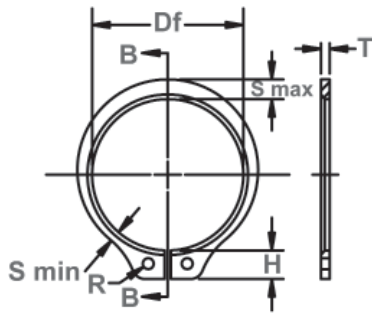

Free Diameter & Ring Measurements with Section B-B

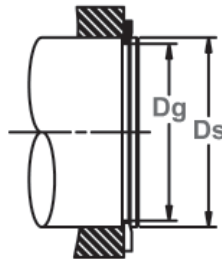

Shaft Diameter & Groove Dimensions

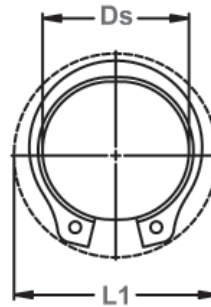

Clearance Diameter Expanded Over Shaft

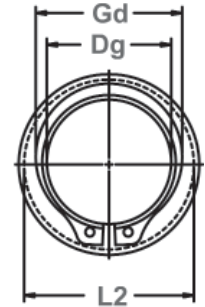

Clearance Diameter & Gaging Diameter Released in Groove

RING NO.	SHAFT DIAMETER			GROOVE SIZE					RING SIZE & WEIGHT					CLEARANCE DIA.			
				DIAMETER		WIDTH		DEPTH	FREE DIAMETER		THICKNESS***		THICKNESS BEVELED END	WEIGHT PER 1000 PCS.	EX-PANDED OVER SHAFT	RE-LEASED IN GROOVE	
	Ds DEC	Ds FRACT	Ds mm	Dg	Tol.	W	Tol.	d	Df	Tol.	T	Tol.	U	Tol.	lbs.	L1	L2
VSH-312	3.125	3-1/8	79.4	2.912		.076		.106	2.892		.093		.070		58.0	3.85	3.76
VSH-315	3.156	3-5/32	80.2	2.940		.076	+ .007	.108	2.920		.093		.070		59.0	3.88	3.78
VSH-325	3.250	3-1/4	82.5	3.026		.076	- .000	.112	3.006		.093		.070	± .002	62.0	3.93	3.83
VSH-334	3.346	3-11/32	85.0	3.112		.075		.117	3.092		.093		.069		64.0	4.02	3.92
VSH-343	3.438	3-7/16	87.3	3.199		.075		.119	3.179		.093		.069		66.0	4.12	4.01
VSH-350	3.500	3-1/2	88.9	3.257		.091		.121	3.237		.109		.084		72.0	4.16	4.05
VSH-354	3.543	-	90.0	3.297	+ .000	.091		.123	3.277		.109		.084		73.0	4.25	4.14
VSH-362	3.625	3-5/8	92.1	3.372	- .006	.090		.126	3.352	+ .020	.109		.083		76.0	4.33	4.21
VSH-368	3.688	3-11/16	93.7	3.430	.006*	.090		.129	3.410	- .030	.109	± .003	.083		80.0	4.39	4.27
VSH-375	3.750	3-3/4	95.2	3.488		.089		.131	3.468		.109		.082		83.0	4.52	4.40
VSH-387	3.875	3-7/8	98.4	3.604		.089		.135	3.584		.109		.082		88.0	4.62	4.49
VSH-393	3.938	3-15/16	100.0	3.662		.088		.138	3.642		.109		.081	± .0025	95.0	4.70	4.57
VSH-400	4.000	4	101.6	3.720		.088		.140	3.700		.109		.081		101.0	4.76	4.63
VSH-425	4.250	4-1/4	108.0	4.009		.094		.120	3.989		.109		.087		112.0	4.98	4.87
VSH-437	4.375	4-3/8	111.1	4.126		.094		.124	4.106		.109		.087		115.0	5.11	4.99
VSH-450	4.500	4-1/2	114.3	4.243		.094		.128	4.223		.109		.087		132.0	5.37	5.25
VSH-475	4.750	4-3/4	120.6	4.478		.092	+ .008	.136	4.458		.109		.085		113.0	5.62	5.49
VSH-500	5.000	5	127.0	4.712		.091	- .000	.144	4.692		.109		.084		149.0	5.87	5.74
VSH-525	5.250	5-1/4	133.3	4.947	+ .000	.105		.151	4.927		.125		.098		190.0	6.20	6.05
VSH-550	5.500	5-1/2	139.7	5.182	- .007	.104		.159	5.162	+ .020	.125	± .004	.097		201.0	6.45	6.30
VSH-575	5.750	5-3/4	146.0	5.416	.006*	.103		.167	5.396	- .040	.125		.096		199.0	6.69	6.53
VSH-600	6.000	6	152.4	5.651		.102		.174	5.631		.125		.095		210.0	6.95	6.78
VSH-625	6.250	6-1/4	158.7	5.886		.132		.182	5.866		.156		.124		282.0	7.31	7.14
VSH-650	6.500	6-1/2	165.1	6.120		.131		.190	6.100	+ .020	.156		.123		330.0	7.67	7.49
VSH-675	6.750	6-3/4	171.4	6.355		.130		.197	6.335	- .050	.156		.122	± .003	356.0	8.06	7.87
VSH-700	7.000	7	177.8	6.590	+ .000	.129		.205	6.570		.156		.121		388.0	8.13	7.93
VSH-750	7.500	7-1/2	190.5	7.059	- .008	.158		.220	7.039		.187	± .005	.149		534.0	8.70	8.49
VSH-800	8.000	8	203.2	7.528	.006*	.157		.236	7.508		.187		.148		628.0	9.24	9.01
VSH-850	8.500	8-1/2	215.9	7.997		.154		.251	7.977	+ .020	.187		.145		700.0	9.79	9.54
VSH-900	9.000	9	228.6	8.465		.153		.267	8.445	- .060	.187		.144		757.0	10.60	10.34
VSH-950	9.500	9-1/2	241.3	8.935		.150		.282	8.915		.187		.141		820.0	11.10	10.82
VSH-1000	10.000	10	254.0	9.405		.148		.297	9.385		.187		.139		964.0	11.61	11.32

\* F.I.M. (FULL INDICATOR MOVEMENT)-MAXIMUM ALLOWABLE DEVIATION OF CONCENTRICITY BETWEEN GROOVE AND SHAFT.  
 \*\*\*FOR PLATED RINGS ADD .002" TO THE LISTED MAXIMUM THICKNESS. MAXIMUM RING THICKNESS WILL BE A MINIMUM OF .0002" LESS THAN THE LISTED GROOVE WIDTH (W) MINIMUM.

Note: Specifications listed within the catalog tables reflect Rotor Clip's standard commercial production dimensions. Published retaining ring standards including Military (MIL-DTL-21248D) / ASME / NAS / ANSI may require parts with alternative geometry. Please contact Rotor Clip Technical Sales Department to clarify conformance to specific requirements. (Tech@rotorclip.com or +1-732-469-7333.)

HARDNESS RANGES: STAINLESS STEEL RINGS (PH 15-7MO)			
RING TYPE	SIZE RANGE	SCALE	ROCKWELL HARDNESS
VSH	All	C	44-51





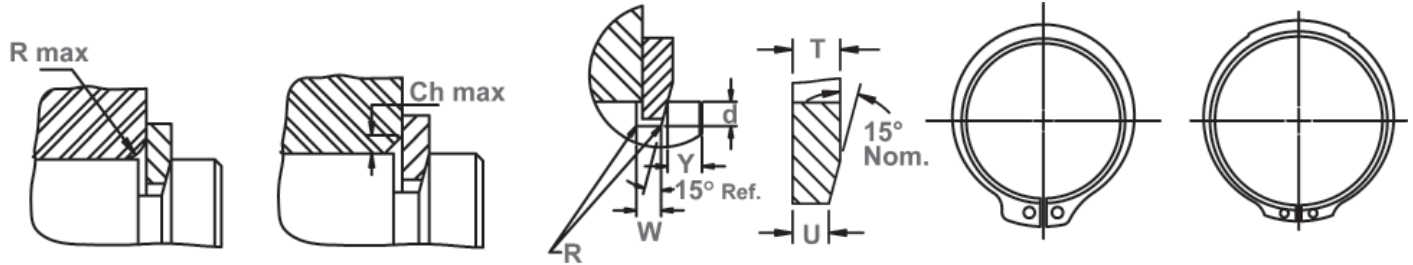

Maximum Corner Radius & Chamfer

Exploded Groove Profile & Edge Margin  
Maximum bottom radii (R), .005 for ring sizes -100 thru -200; .010 for ring sizes -206 thru -1000

Asymmetrical Design  
Manufacturer's Option

Alternate Lug Design  
Manufacturer's Option  
For Larger Sizes

RING NO.	ALLOWABLE CORNER RADII & CHAMFERS		MAX. LOAD W/ R MAX OR CH MAX (IN LBS.)	EDGE MARGIN	END-PLAY TAKE-UP	LUG HEIGHT		MAXIMUM SECTION		MINIMUM SECTION		HOLE DIAMETER		GAGING DIA.	THRUST LD. (LBS.) SQR. CORNER ABUTMENT		
	R max	Ch max				P'r	Y	In.	H	Tol.	S max	Tol.	S min		Tol.	R	Tol.
VSH-312	.120	.072	7350	.159	.014	.324		.272		.141		.125		3.439	34815	11700	
VSH-315	.1205	.072	7350	.162	.0145	.324		.274		.143		.125		3.469	35119	11900	
VSH-325	.123	.074	7350	.168	.015	.300		.300		.145		.125		3.571	36134	12700	
VSH-334	.126	.076	7350	.175	.0155	.300		.300		.147		.125		3.669	37251	13600	
VSH-343	.129	.077	7350	.178	.016	.300		.300		.148		.125		3.767	38266	14300	
VSH-350	.122	.073	10500	.181	.016	.285		.285		.148		.125		3.821	45574	14800	
VSH-354	.123	.074	10500	.184	.0165	.310	±.005	.310	±.008	.149	±.008	.125		3.866	46183	15200	
VSH-362	.127	.076	10500	.189	.017	.310		.310		.153		.125	+ .015	3.956	47299	16300	
VSH-368	.1295	.078	10500	.193	.017	.310		.310		.156		.125	- .002	4.026	48010	16500	
VSH-375	.133	.080	10500	.196	.0175	.342		.342		.160		.125		4.098	48822	17200	
VSH-387	.137	.082	10500	.202	.018	.342		.342		.163		.125		4.229	50446	18300	
VSH-393	.137	.082	10500	.207	.0185	.342		.342		.163		.125		4.290	51359	19000	
VSH-400	.135	.081	10500	.210	.019	.342		.342		.163		.125		4.350	52171	19600	
VSH-425	.146	.088	10500	.180	.016	.342		.342		.176		.125		4.620	55419	18000	
VSH-437	.146	.088	10500	.186	.017	.342		.342		.181		.125		4.740	57043	19000	
VSH-450	.102	.061	10500	.192	.017	.405		.405		.185		.125		4.920	58667	20200	
VSH-475	.115	.069	10500	.204	.018	.405		.405		.136		.125		5.060	61915	22700	
VSH-500	.165	.099	10500	.216	.019	.405	±.008	.405	±.010	.194	±.010	.156		5.410	65163	25400	
VSH-525	.169	.101	13500	.226	.020	.435		.435		.211		.156		5.670	78460	28000	
VSH-550	.175	.105	13500	.238	.021	.497		.390		.209		.156		5.940	82215	30800	
VSH-575	.184	.110	13500	.250	.022	.518		.435		.220		.156		6.210	85971	33800	
VSH-600	.143	.086	13500	.261	.023	.540		.435		.171		.156		6.380	89625	37000	
VSH-625	.148	.089	21000	.273	.024	.561		.485		.176		.156		6.650	116522	40000	
VSH-650	.191	.114	21000	.285	.025	.586		.485		.236		.156	+ .020	6.980	121191	43500	
VSH-675	.200	.120	21000	.295	.026	.608		.515		.246		.187	- .005	7.260	125860	47000	
VSH-700	.208	.125	21000	.307	.027	.530		.515		.256		.187		7.520	130529	50500	
VSH-750	.220	.132	30000	.330	.029	.676	±.012	.545	±.015	.277	±.015	.187		8.060	167678	58000	
VSH-800	.235	.141	30000	.354	.032	.735		.560		.294		.187		8.590	178843	66500	
VSH-850	.250	.150	30000	.376	.034	.735		.580		.314		.187		9.130	190008	75000	
VSH-900	.267	.160	30000	.400	.036	.735		.609		.333		.187		9.670	201173	86000	
VSH-950	.281	.168	30000	.423	.038	.735		.642		.350		.187		10.200	212338	94500	
VSH-1000	.294	.176	30000	.445	.040	.735		.675		.367		.187		10.730	223503	105000	

† BASED ON HOUSINGS/SHAFTS MADE OF COLD ROLLED STEEL. FOR AN EXPLANATION OF FORMULAS USED TO DERIVE THRUST LOAD AND OTHER PERFORMANCE DATA, CONTACT THE ROTOR CLIP ENGINEERING DEPARTMENT.

HARDNESS RANGES: CARBON STEEL RINGS (SAE 1060-1090)

RING TYPE	SIZE RANGE	SCALE	ROCKWELL HARDNESS
VSH	100-102	C	47-53
	106-343	C	47-52
	350-700	C	44-51
	725-1000	C	40-47

HARDNESS RANGES: BERYLLIUM COPPER RINGS

RING TYPE	SIZE RANGE	SCALE	ROCKWELL HARDNESS
VSH	100-102	30N	56.5-62
	106+	C	37-43





# E Shaft Rings

## Radially Assembled, External 'E'

Perhaps the most popular and widely used radial retaining ring is the "E" (so named because it is shaped like the letter "E".) Three prongs make contact with the bottom of the groove and provide a shoulder for effective retention of assemblies.

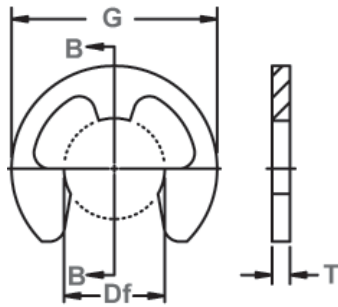

Free Diameter & Ring Measurements  
With Section B-B

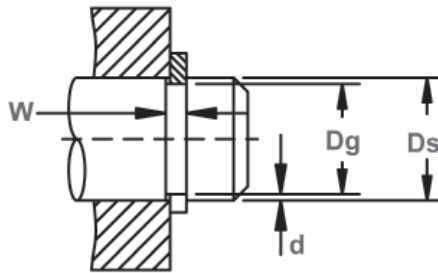

Shaft Diameter &  
Groove Dimensions

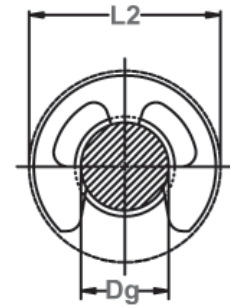

Clearance Diameter  
Installed In Groove

RING NO.	SHAFT DIAMETER			GROOVE SIZE			RING SIZE & WEIGHT				CLEARANCE DIA.		THRUST LD. (lbs.)				
				DIAMETER		WIDTH	DEPTH	FREE DIAMETER		THICKNESS***		Free outside dia. REF.	Installed in groove	Sqr. corner abutment			
	Ds DEC	Ds FRAC	Ds mm	Dg	Tol.	W	Tol.	d	Df	Tol.	T	Tol.	lbs.	G	L2	Pr	Pg
**E-4	.040	-	1.0	.026		.012		.007	.025		.010		.009	.079	.090	13	6
E-6	.062	1/16	1.6	.052		.012		.005	.051	+ .001	.010	± .001	.030	.156	.165	20	7
SE-6	.062	1/16	1.6	.052	+ .002	.012		.005	.051	- .003	.010		.028	.140	.150	20	7
YE-6	.062	1/16	1.6	.052		.023		.005	.051		.020		.094	.187	.200	41	7
SE-9	.094	3/32	2.4	.074	- .000	.020	+ .002	.010	.069	+ .002-.003	.015		.10	.230	.245	46	20
E-9	.094	3/32	2.4	.074	*.0015	.020	- .000	.010	.073		.015		.058	.187	.200	46	20
SE-11	.110	7/64	2.8	.079		.020		.015	.076		.015		.31	.375	.390	61	40
SE-12	.125	1/8	3.2	.095		.029		.015	.094		.025		.12	.214	.225	110	45
E-12	.125	1/8	3.2	.095		.020		.015	.094		.015		.087	.230	.240	66	45
SE-14	.140	9/64	3.6	.102		.020		.019	.100		.015		.060	.203	.215	76	60
YE-14	.140	9/64	3.6	.110		.020		.015	.108		.015		.10	.250	.265	76	45
E-14	.140	9/64	3.6	.105		.029		.017	.102	+ .001	.025		.21	.270	.285	173	60
SE-15	.156	5/32	4.0	.118	+ .002	.046		.019	.116	- .003	.042		.76	.375	.390	300	70
E-15	.156	5/32	4.0	.116		.029		.020	.114		.025		.21	.282	.295	178	75
SE-17	.172	11/64	4.4	.127	- .000	.029		.022	.125		.025		.24	.312	.325	183	90
SE-18	.188	3/16	4.8	.125	*.002	.029		.031	.122		.025		.45	.375	.39	203	135
YE-18	.188	3/16	4.8	.147		.029		.020	.145		.025	± .002	.70	.470	.485	193	90
ZE-18	.188	3/16	4.8	.125		.029		.031	.122		.025		1.05	.550	.565	203	135
E-18	.188	3/16	4.8	.147		.029		.020	.145		.025		.29	.335	.35	193	90
SE-21	.219	7/32	5.6	.188		.029		.015	.185		.025		.47	.437	.45	228	75
E-25	.250	1/4	6.3	.210		.029		.020	.207		.025		.76	.527	.54	259	115
SE-31	.312	5/16	7.9	.250		.029	+ .003	.031	.243		.025		.57	.500	.52	330	225
YE-31	.312	5/16	7.9	.250		.029	- .000	.031	.243		.025		1.220	.670	.685	325	220
SE-37	.375	3/8	9.5	.306		.039		.034	.303	+ .002	.035		1.050	.567	.587	680	300
E-37	.375	3/8	9.5	.303	+ .003	.039		.036	.300	- .004	.035		1.5	.660	.68	700	315
E-43	.438	7/16	11.1	.343	- .000	.039		.047	.337		.035		1.5	.687	.71	842	480
SE-43	.438	7/16	11.1	.380	*.004	.039		.029	.375		.035		1.0	.600	.62	812	280
E-50	.500	1/2	12.7	.396		.046		.052	.392		.042		2.5	.800	.82	1127	600
E-62	.625	5/8	15.9	.485		.046		.070	.480		.042		3.2	.940	.96	1441	1050
SE-74	.750	3/4	19.0	.625		.056		.062	.616	+ .003	.050		4.3	1.000	1.02	1979	1100
E-75	.750	3/4	19.0	.580		.056		.085	.574	- .005	.050		5.8	1.120	1.14	2030	1500
E-87	.875	7/8	22.2	.675		.056		.100	.668		.050		7.6	1.300	1.32	2385	2050
SE-98	.984	63/64	25.0	.835		.056		.074	.822		.050		9.2	1.500	1.53	2639	1750
SE-98	1.000	1	25.4	.835		.056		.082	.822		.050		9.2	1.500	1.53	2690	1900
SE-118	1.188	1-3/16	30.2	1.079	+ .005	.068	+ .004	.054	1.066	+ .006	.062	± .003	11.3	1.626	1.67	3501	1500
SE-137	1.375	1-3/8	34.9	1.230	- .000 * .005	.068	- .000	.072	1.213	- .010	.062		15.4	1.875	1.92	4162	2350

LISTED GROOVE WIDTH (W) MINIMUM.

\* F.I.M. (FULL INDICATOR MOVEMENT)- MAXIMUM ALLOWABLE DEVIATION OF CONCENTRICITY BETWEEN GROOVE AND SHAFT.

\*\* AVAILABLE IN BERYLLIUM COPPER ONLY.

† BASED ON GROOVES MADE OF COLD ROLLED STEEL. FOR AN EXPLANATION OF FORMULAS USED TO DERIVE THRUST LOAD AND OTHER PERFORMANCE DATA CONTACT THE ROTOR CLIP ENGINEERING DEPARTMENT.

\*\*\* FOR PLATED RINGS, ADD .002" TO THE LISTED MAXIMUM THICKNESS. MAXIMUM THICKNESS WILL BE A MINIMUM OF .0002" LESS THAN THE LISTED GROOVE WIDTH (W) MINIMUM.

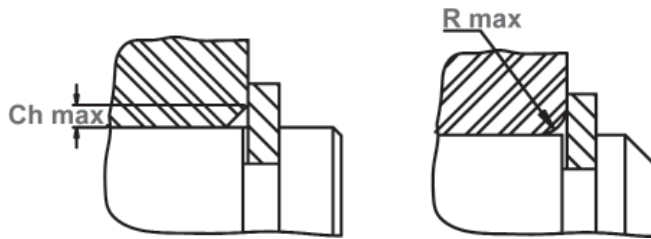

Maximum Corner Radius & Chamfer

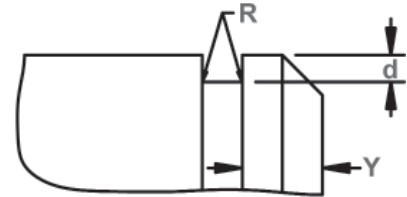

Exploded Groove Profile & Edge Margin (Y)  
 Maximum bottom radii (R), Sharp corners  
 for rings 4 thru 6; .005 For sizes SE9 thru 25; .010  
 For sizes SE-31 thru SE-43; .015 For sizes 50 thru SE-137

RING NO.	ALLOWABLE CORNER RADII & CHAMFERS		MAX LOAD w/ R max or Ch max (in lbs.)	EDGE MARGIN	R.P.M. LIMITS Standard material
	R max	Ch max			
**E-4	.015	.010	13	.014	40000
E-6	.030	.020	20	.010	40000
SE-6	.030	.020	20	.010	40000
YE-6	.035	.025	40	.010	40000
SE-9	.053	.040	45	.020	36000
E-9	.040	.030	45	.020	36000
SE-11	.080	.060	60	.030	35000
SE-12	.040	.030	108	.030	35000
E-12	.040	.030	65	.030	35000
SE-14	.029	.022	75	.038	32000
YE-14	.040	.030	75	.030	32000
E-14	.060	.045	170	.034	32000
SE-15	.080	.060	250	.038	31000
E-15	.060	.045	175	.040	31000
SE-17	.060	.045	180	.044	30000
SE-18	.060	.045	200	.062	30000
YE-18	.060	.045	190	.040	25000
ZE-18	.060	.045	200	.062	18000
E-18	.060	.045	190	.040	30000
SE-21	.060	.045	225	.030	26000
E-25	.060	.045	255	.040	25000
SE-31	.060	.045	325	.062	22000
YE-31	.060	.045	320	.062	15000
SE-37	.060	.045	680	.068	20000
E-37	.065	.050	690	.072	20000
E-43	.065	.050	830	.094	16500
SE-43	.050	.035	800	.058	16500
E-50	.080	.060	1110	.104	14000
E-62	.080	.060	1420	.140	12000
SE-74	.057	.042	1900	.124	11000
E-75	.085	.065	2000	.170	10500
E-87	.085	.065	2350	.200	9000
SE-98	.085	.065	2700	.148	6500
SE-98	.077	.057	2700	.164	6500
SE-118	.090	.070	3450	.108	5500
SE-137	.090	.070	4100	.144	4000

LARGER SIZES MAY BE AVAILABLE UPON REQUEST.

HARDNESS RANGES: STAINLESS STEEL RINGS (PH 15-7MO)

RING TYPE	SIZE RANGE	SCALE	ROCKWELL HARDNESS
E All	E6-SE6	15N	82.5-86*
	YE6-YE14	15N	82.5-86
	E14-SE31	30N	63-69.5
	E37+	C	44-51

HARDNESS RANGES: BERYLLIUM COPPER RINGS

RING TYPE	SIZE RANGE	SCALE	ROCKWELL HARDNESS
E All	E4-SE6	15N	79-82*
	YE6-YE14	15N	79-82
	E14-SE31	30N	56.5-62
	E37+	C	37-43

HARDNESS RANGES: CARBON STEEL RINGS (SAE 1060-1090)

RING TYPE	SIZE RANGE	SCALE	ROCKWELL HARDNESS
E All	E6-SE6	15N	84.5-87*
	YE6-YE14	15N	84.5-87
	E14-SE31	30N	66.5-71
	E37+	C	47-52

\*HARDNESS CAN NOT BE CHECKED WITH ANY DEGREE OF ACCURACY DIRECTLY ON THESE RINGS.



# RE Shaft Rings

## Radially Assembled, External Reinforced 'E'

The RE retaining ring is a reinforced version of the E ring, which will accommodate higher thrust loadings and RPM. RE rings function in the same groove as regular E rings, so that you can change from one to the other without re-engineering the application.

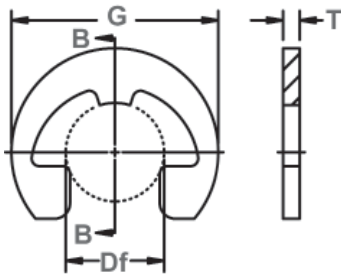

Free Diameter & Ring Measurements with Section B-B

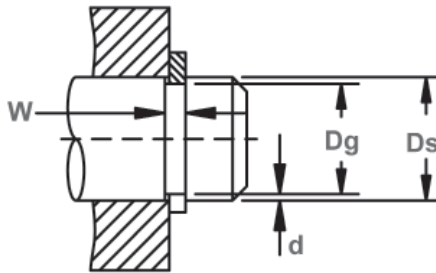

Shaft Diameter & Groove Dimensions

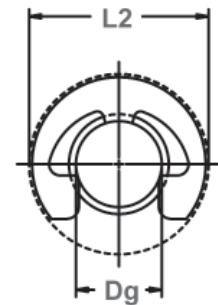

Clearance Diameter Installed In Groove

RING NO.	SHAFT DIAMETER			GROOVE SIZE					RING SIZE & WEIGHT					CLEARANCE DIA.		i THRUST LD. (lbs.)	
				DIAMETER		WIDTH		DEPTH	FREE DIAMETER			THICKNESS***		Weight. Per 1000 Pcs.	Free Out-Side Dia.	Installed In Groove	Sqr. Corner Abutment
	Ds DEC	Ds FRACT	Ds mm	Dg	Tol.	W	Tol.	d	Df	Tol.	T	Tol.	lbs.		Ref. G	L2	Pr
RE-9	.094	3/32	2.4	.074	+.002	.020	+.002	.010	.072	+.001	.015		.07	.206	.219	51	13
RE-12	.125	1/8	3.2	.095	-.000	.020	-.000	.015	.093	-.003	.015		.13	.270	.283	76	25
RE-15	.156	5/32	4.0	.116	.0015*	.029		.020	.113	+.002-.003	.025		.31	.335	.35	152	40
RE-18	.188	3/16	4.8	.147		.029		.020	.143		.025		.39	.375	.39	183	50
RE-21	.219	7/32	5.6	.188	±.002	.029		.015	.182	±.003	.025	±.002	.54	.446	.46	223	50
RE-25	.250	1/4	6.3	.210	.002*	.029		.020	.204		.025		.71	.516	.53	254	75
RE-31	.312	5/16	7.9	.250	±.003	.029	+.003	.031	.242		.025		.85	.588	.61	305	135
RE-37	.375	3/8	9.5	.303	.003*	.039	-.000	.036	.292		.035		1.5	.660	.68	528	190
RE-43	.438	7/16	11.1	.343		.039		.047	.332		.035		1.9	.746	.77	609	285
RE-50	.500	1/2	12.7	.396	±.003	.046		.052	.385	±.004	.042		3.2	.810	.83	832	360
RE-56	.562	9/16	14.3	.437	.004*	.046		.062	.430		.042		3.5	.870	.89	944	480

\*F.I.M. (FULL INDICATOR MOVEMENT)-MAXIMUM ALLOWABLE DEVIATION OF CONCENTRICITY BETWEEN GROOVE AND SHAFT.

i BASED ON HOUSINGS/SHAFTS MADE OF COLD ROLLED STEEL. FOR AN EXPLANATION OF FORMULAS USED TO DERIVE THRUST LOAD AND OTHER PERFORMANCE DATA, CONTACT THE ROTOR CLIP ENGINEERING DEPT.

\*\*\* FOR PLATED RINGS, ADD .002" TO THE LISTED MAXIMUM THICKNESS. MAXIMUM RING THICKNESS WILL BE A MINIMUM OF .0002" LESS THAN THE LISTED GROOVE WIDTH (W) MINIMUM.

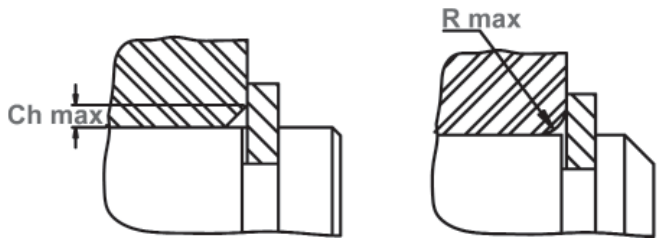

Maximum Corner Radius & Chamfer

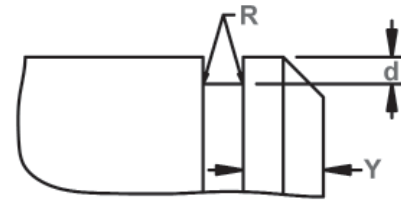

Exploded Groove Profile & Edge Margin (Y)  
 Maximum bottom radii (R), .005 for ring sizes  
 -9 thru -25; .010 for ring sizes -31 thru -43;  
 .015 for ring sizes -50 thru -56

RING NO.	ALLOWABLE CORNER RADII & CHAMFERS		MAX. LOAD W/ R MAX or Ch max (in lbs.)	EDGE MARGIN		R.P.M. LIMITS Standard Material
	R max	Ch max		P'r	Y	
RE-9	.045	.033	50	.020	90000	
RE-12	.045	.033	75	.030	70000	
RE-15	.065	.050	150	.040	60000	
RE-18	.065	.050	180	.040	50000	
RE-21	.065	.050	220	.031	43000	
RE-25	.065	.050	250	.040	38000	
RE-31	.070	.055	300	.062	32000	
RE-37	.070	.055	520	.072	28000	
RE-43	.070	.055	600	.094	24000	
RE-50	.080	.060	820	.104	20000	
RE-56	.080	.060	930	.124	17000	

NOTE: CONTACT ROTOR CLIP FOR AVAILABILITY OF SIZES LISTED. LARGER SIZES MAY BE AVAILABLE UPON REQUEST.

HARDNESS RANGES: STAINLESS STEEL RINGS (PH 15-7MO)

RING TYPE	SIZE RANGE	SCALE	ROCKWELL HARDNESS
RE	9&12	15N	82.5-86
	15-31	30N	63-69.5
	37+	C	44-51

HARDNESS RANGES: BERYLLIUM COPPER RINGS

RING TYPE	SIZE RANGE	SCALE	ROCKWELL HARDNESS
RE	9&12	15N	77-82
	15-31	30N	54-62
	37+	C	34-43

HARDNESS RANGES: CARBON STEEL RINGS (SAE 1060-1090)

RING TYPE	SIZE RANGE	SCALE	ROCKWELL HARDNESS
RE	9&12	15N	84.5-87
	15-31	30N	66.5-71
	37 +	C	47-52

# C Shaft Rings

## Radially Assembled, External Crescent

Ideal for low clearance applications where radial installation is preferred.

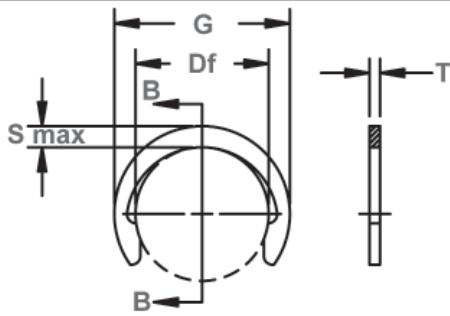

Free Diameter & Ring Measurements with Section B-B

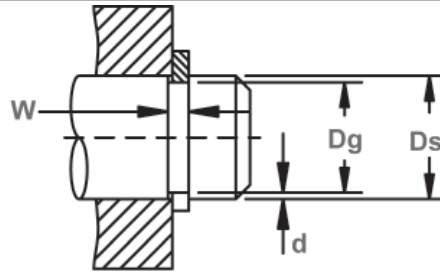

Shaft Diameter & Groove Dimensions

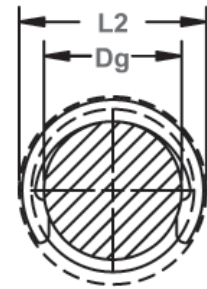

Clearance Diameter Installed In Groove

RING NO.	SHAFT DIAMETER			GROOVE SIZE			RING SIZE & WEIGHT				CLEARANCE DIA.			THRUST LD. (lbs.)			
				DIAMETER		WIDTH	DEPTH	FREE DIAMETER		THICKNESS**		Wght. Per 1000 Pcs.	Free outside dia. REF.	Re-released in groove	Sqr. Corner Abutment		
	Ds DEC	Ds FRACT	Ds mm	Dg	Tol.	W	Tol.	d	Df	Tol.	T				Tol.	lbs.	G
C-12	.125	1/8	3.2	.106	±.0015	.020	+ .002	.0095	.102	+ .002	.015		.030	.165	.18	86	45
C-15	.156	5/32	4.0	.135	*.0015	.020	- .000	.0105	.131	- .004	.015		.052	.205	.22	102	55
C-18	.188	3/16	4.8	.165		.020		.011	.161		.015		.062	.244	.25	132	70
C-21	.219	7/32	5.6	.193	±.002*.0015	.029		.013	.187		.025		.120	.275	.29	264	100
C-23	.236	15/64	6.0	.208	±.002*.002	.029		.014	.203		.025		.15	.295	.31	284	115
C-25	.250	1/4	6.4	.220		.029		.015	.211	+ .003	.025		.157	.311	.33	294	130
C-28	.281	9/32	7.1	.247		.029		.017	.242	- .005	.025		.19	.346	.36	335	165
C-31	.312	5/16	7.9	.276	±.002	.029		.018	.270		.025		.226	.376	.39	376	200
C-37	.375	3/8	9.5	.335	*.002	.029		.020	.328		.025		.300	.448	.47	447	270
C-40	.406	13/32	10.3	.364		.029		.021	.359		.025		.352	.486	.50	487	300
C-43	.438	7/16	11.1	.393		.029		.022	.386		.025		.359	.517	.53	528	350
C-50	.500	1/2	12.7	.450		.039	+ .003	.025	.441	±.006	.035	±.002	.671	.581	.60	842	450
C-56	.562	9/16	14.3	.507		.039	- .000	.028	.497		.035		.710	.653	.67	944	550
C-62	.625	5/8	15.9	.563		.039		.031	.553		.035		.937	.715	.74	1045	700
C-68	.688	11/16	17.5	.619	±.003	.046		.034	.608		.042		1.3	.784	.80	1726	800
C-75	.750	3/4	19.0	.676	*.004	.046		.037	.665		.042		1.5	.845	.87	1878	1000
C-81	.812	13/16	20.6	.732		.046		.040	.721	±.007	.042		1.7	.915	.94	2040	1150
C-87	.875	7/8	22.2	.789		.046		.043	.777		.042		2.0	.991	1.01	2202	1300
C-93	.938	15/16	23.8	.843		.046		.047	.830		.042		2.3	1.058	1.08	2355	1550
C-100	1.000	1	25.4	.900		.046		.050	.887		.042		2.7	1.130	1.15	2517	1800
C-112	1.125	1-1/8	28.6	1.013		.056		.056	.997		.050		4.0	1.267	1.30	3370	2200
C-125	1.250	1-1/4	31.7	1.126	±.004	.056		.062	1.110	±.008	.050		5.1	1.415	1.44	3735	2700
C-137	1.375	1-3/8	34.9	1.237	*.005	.056	+ .004	.069	1.220		.050		6.1	1.555	1.58	4111	3350
C-150	1.500	1-1/2	38.1	1.350		.056	- .000	.075	1.331		.050		7.6	1.691	1.72	4486	4000
C-162	1.625	1-5/8	41.3	1.483	±.005	.068		.071	1.463		.062		11.0	1.853	1.88	5506	4650
C-175	1.750	1-3/4	44.4	1.576	*.005	.068		.087	1.555	±.010	.062	±.003	12.9	1.975	2.01	6526	5300
C-200	2.000	2	50.8	1.800		.068		.100	1.777		.062		16.2	2.257	2.30	7410	7000

\*F.I.M.(FULL INDICATOR MOVEMENT)-MAXIMUM ALLOWABLE DEVIATION OF CONCENTRICITY BETWEEN GROOVE AND SHAFT.

† BASED ON HOUSINGS/SHAFTS MADE OF COLD ROLLED STEEL. FOR AN EXPLANATION OF FORMULAS USED TO DERIVE THRUST LOAD AND OTHER PERFORMANCE DATA, CONTACT THE ROTOR CLIP ENGINEERING DEPT.

\*\* FOR PLATED RINGS ADD .002" TO THE LISTED MAXIMUM THICKNESS. MAXIMUM RING THICKNESS WILL BE A MINIMUM OF .0002" LESS THAN THE LISTED GROOVE WIDTH (W) MINIMUM.

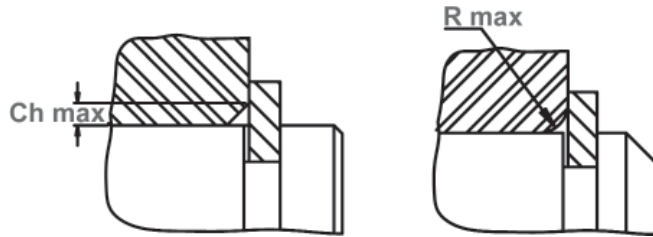

Maximum Corner Radius & Chamfer

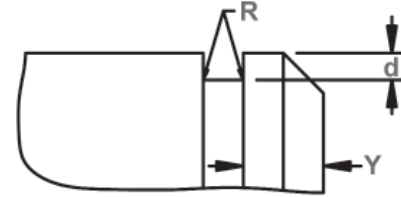

Enlarged Groove Profile & Edge Margin (Y)  
 Maximum bottom radii (R), .005 For rings sizes  
 -12 thru -43; .010 For ring sizes -46 thru -100;  
 .015 For sizes -112 thru -200

RING NO.	MAXIMUM SECTION		ALLOWABLE CORNER RADII & CHAMFERS		MAX LOAD w/ R max or Ch max (in lbs.)	EDGE MARGIN		R.P.M. LIMITS Standard material
	S max	Tol.	R max	Ch max		P'r	Y	
C-12	.031	± .003	.014	.011	85	.020	80000	
C-15	.037		.018	.014	100	.020	75000	
C-18	.042		.021	.016	110	.022	73000	
C-21	.044		.021	.016	260	.026	71000	
C-23	.046	± .004	.022	.017	275	.028	62000	
C-25	.050		.023	.018	290	.030	60000	
C-28	.051		.021	.016	310	.034	56000	
C-31	.053		.024	.018	310	.036	52000	
C-37	.060		.026	.020	310	.040	43000	
C-40	.063	± .005	.027	.021	310	.042	40000	
C-43	.065		.029	.022	310	.044	31000	
C-50	.070		.030	.023	610	.050	25000	
C-56	.078		.033	.025	610	.056	22000	
C-62	.081		.033	.025	610	.062	20000	
C-68	.086		.034	.026	880	.068	18500	
C-75	.090		.036	.027	880	.074	17500	
C-81	.097		.038	.029	880	.080	16000	
C-87	.105		.040	.031	880	.086	15000	
C-93	.112		.043	.033	880	.094	14000	
C-100	.120	± .007	.046	.035	880	.100	12500	
C-112	.135		.052	.040	1250	.112	11500	
C-125	.150		.057	.044	1250	.124	10500	
C-137	.165		.062	.048	1250	.138	9500	
C-150	.180		.069	.053	1250	.150	8500	
C-162	.195		.075	.058	1920	.162	8000	
C-175	.210		.081	.062	1920	.174	7500	
C-200	.240		.091	.070	1920	.200	6000	

LARGER SIZES MAY BE AVAILABLE UPON REQUEST.

HARDNESS RANGES: STAINLESS STEEL RINGS (PH 15-7MO)

RING TYPE	SIZE RANGE	SCALE	ROCKWELL HARDNESS
C	12-18	15N	82.5-86*
	21-81	30N	63-69.5
	87+	C	44-51

HARDNESS RANGES: BERYLLIUM COPPER RINGS

RING TYPE	SIZE RANGE	SCALE	ROCKWELL HARDNESS
C	12-62	15N	77-82*
	68-81	30N	54-62
	87+	C	34-43

HARDNESS RANGES: CARBON STEEL RINGS (SAE 1060-1090)

RING TYPE	SIZE RANGE	SCALE	ROCKWELL HARDNESS
C	12-18	15N	86-88.5*
	21-43	30N	67.5-72
	50-81	30N	66-71
	87+	C	47-52

\*HARDNESS CAN NOT BE CHECKED WITH ANY DEGREE OF ACCURACY DIRECTLY ON THESE RINGS.



# LC Shaft Rings

## Radially Assembled, External Interlocking

The LC ring is produced in two identical halves. The ends interlock into a groove on a shaft and, once assembled, are dynamically balanced. As a result, they are particularly effective at retaining assemblies with extremely high rotational speeds.

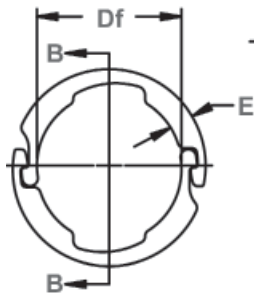

Free Diameter & Ring Measurements with Section B-B

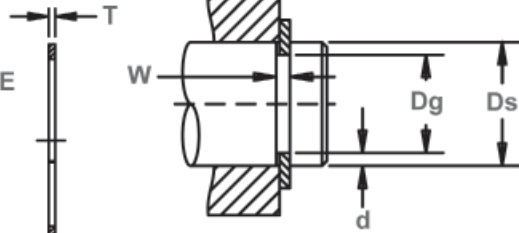

Shaft Diameter & Groove Dimensions



Plier Notch Design (Call for additional information)

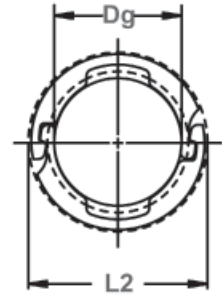

Clearance Diameter Installed in Groove

RING NO.	SHAFT DIAMETER			GROOVE SIZE			RING SIZE & WEIGHT				CLEARANCE	i Thrust Id. (lbs.) Sq. Corner Abutment				
				DIAMETER		WIDTH	DEPTH	FREE DIAMETER		THICKNESS***		Weight Per 1000 Rings (2 Halves)	Installed in groove	Ring Safety factor of 3	Groove Safety factor of 2	
	Ds DEC	Ds FRACT	Ds mm	Dg	Tol.	W	Tol.	d	Df	Tol.	T					Tol.
LC-46	.469	15/32	11.9	.419	±.0015	.039		.025	.414		.035		1.36	.640	2030	620
LC-50	.500	1/2	12.7	.464	.004*	.039		.018	.459		.035		1.50	.680	2132	480
LC-59	.594	19/32	15.1	.544		.039	+ .003	.025	.538	±.002	.035		1.74	.766	2538	790
LC-62	.625	5/8	15.9	.575		.039	- .000	.025	.569		.035		1.82	.797	2690	830
LC-66	.669	-	17.0	.599		.046		.035	.593		.042		3.1	.886	3400	1250
LC-75	.750	3/4	19.0	.680	±.002	.046		.035	.673	±.003	.042	±.002	3.5	.967	3806	1400
LC-78	.781	25/32	19.8	.711	*.004	.046		.035	.703		.042		3.6	.998	4009	1450
LC-87	.875	7/8	22.2	.805		.046		.035	.796		.042		3.8	1.092	4466	1600
LC-98	.984	63/64	25.0	.872	±.003	.056		.056	.863		.050		7.3	1.273	5938	2900
LC-98	1.000	1	25.4	.872	*.004	.056		.064	.863		.050		7.3	1.273	5938	3400
LC-112	1.125	1-1/8	28.6	1.013		.056		.056	1.002		.050		7.9	1.42	6801	3350
LC-118	1.188	1-3/16	30.2	1.075	±.003	.056	+ .004	.056	1.064	±.004	.050		8.5	1.48	7207	3500
LC-125	1.250	1-1/4	31.7	1.138	*.005	.056	- .000	.056	1.126		.050		8.9	1.54	7562	3700
LC-137	1.375	1-3/8	34.9	1.263		.056		.056	1.250		.050		9.6	1.67	8323	4100
LC-150	1.500	1-1/2	38.1	1.388		.056		.056	1.374		.050		10.6	1.79	9084	4450
LC-156	1.562	1-9/16	39.7	1.427		.068		.068	1.412		.062		16.4	1.91	11926	5650
LC-162	1.625	1-5/8	41.3	1.489		.068		.068	1.474		.062		17.5	1.97	12434	5850
LC-175	1.750	1-3/4	44.4	1.614	±.005	.068		.068	1.597	±.005	.062		18.4	2.10	13398	6300
LC-175	1.772	-	45.0	1.614	*.005	.068		.078	1.597		.062		18.4	2.10	13398	7350
LC-187	1.875	1-7/8	47.6	1.739		.068		.068	1.721		.062		20.8	2.22	14312	6800
LC-196	1.969	1-31/32	50.0	1.797		.086		.086	1.779		.078		31.0	2.37	18524	9000
LC-200	2.000	2	50.8	1.828		.086		.086	1.809		.078		31.6	2.40	18778	9150
LC-212	2.125	2-1/8	54.0	1.953	±.005	.086	+ .005	.086	1.933	±.006	.078	±.003	34.2	2.52	19996	9700
LC-212	2.156	2-5/32	54.8	1.953	*.006	.086	- .000	.101	1.933		.078		34.2	2.52	19996	11500
LC-225	2.250	2-1/4	57.1	2.078		.086		.086	2.057		.078		37.3	2.65	21112	10300
LC-237	2.375	2-3/8	60.3	2.203		.086		.086	2.180		.078		38.9	2.77	22330	10800
LC-250	2.500	2-1/2	63.5	2.328		.086		.086	2.304		.078		39.7	2.90	23548	11400
LC-262	2.625	2-5/8	66.7	2.453		.086		.086	2.428		.078		43.9	3.02	24665	12000
LC-275	2.750	2-3/4	69.8	2.544		.103		.103	2.518		.093		63.2	3.25	30653	15000
LC-287	2.875	2-7/8	73.0	2.669	±.006	.103		.103	2.642	±.008	.093		68.4	3.37	32074	15700
LC-300	3.000	3	76.2	2.794	*.006	.103		.103	2.754		.093		70.4	3.50	33495	16400
LC-325	3.250	3-1/4	82.5	3.044		.103		.103	3.013		.093		77.6	3.75	36286	17800
LC-337	3.375	3-3/8	85.7	3.145		.120		.115	3.114		.109		94.0	3.99	44153	20600

\*F.I.M. (FULL INDICATOR MOVEMENT) - MAXIMUM ALLOWABLE DEVIATION OF CONCENTRICITY BETWEEN GROOVE AND SHAFT.

i BASED ON HOUSINGS/SHAFTS MADE OF COLD ROLLED STEEL. FOR AN EXPLANATION OF FORMULAS USED TO DERIVE THRUST LOAD AND OTHER PERFORMANCE DATA, CONTACT THE ROTOR CLIP ENGINEERING DEPT.

\*\*\*FOR PLATED RINGS, ADD .002" TO THE LISTED MAXIMUM THICKNESS. MAXIMUM RING THICKNESS WILL BE A MINIMUM OF .0002" LESS THAN THE LISTED GROOVE WIDTH (W) MINIMUM.





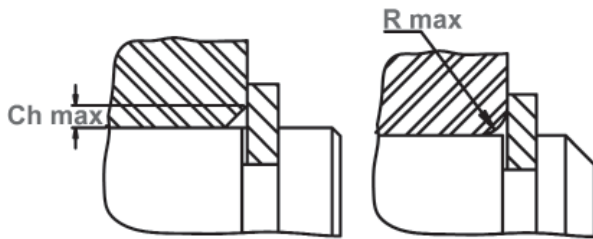

Maximum Corner Radius & Chamfer

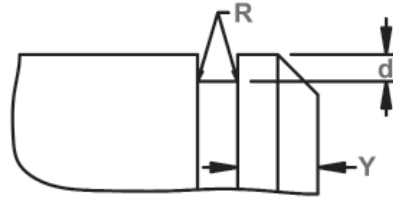

Exploded Groove Profile & Edge Margin (Y)  
 Maximum bottom radii (R): .005 for ring sizes -46 thru -98; .010 for ring sizes -112 thru -200; .015 for ring sizes -212 thru -337.

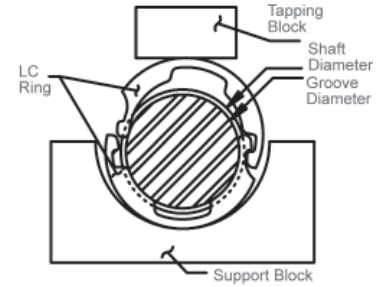

V-Block Assembly

RING NO.	MAXIMUM SECTION		ALLOWABLE CORNER RADII & CHAMFERS		MAX. LOAD W/R max or Ch max (lbs)	EDGE MARGIN	R.P.M. LIMITS Standard Material
	E	Tol.	R max	Ch max			
LC-46	.105	± .005	.052	.040	610	.075	50000
LC-50	.105		.052	.040	610	.054	50000
LC-59	.105		.052	.040	610	.075	46000
LC-62	.105		.052	.040	610	.075	45000
LC-66	.135	± .006	.065	.050	880	.105	43000
LC-75	.135		.065	.050	880	.105	40000
LC-78	.135		.065	.050	880	.105	39000
LC-87	.135		.065	.050	880	.105	35000
LC-98	.188		.086	.066	1250	.168	31000
LC-98	.188		.081	.062	1250	.192	30000
LC-112	.188		.086	.066	1250	.168	28000
LC-118	.188		.086	.066	1250	.168	27000
LC-125	.188	± .007	.086	.066	1250	.168	26000
LC-137	.188		.086	.066	1250	.168	24000
LC-150	.188		.086	.066	1250	.168	22000
LC-156	.222		.100	.077	1900	.204	21000
LC-162	.222		.100	.077	1900	.204	20500
LC-175	.222		.100	.077	1900	.204	19000
LC-175	.222		.094	.072	1900	.234	19000
LC-187	.222		.100	.077	1900	.204	17000
LC-196	.262		.114	.088	3050	.258	15500
LC-200	.262		.114	.088	3050	.258	15000
LC-212	.262		.114	.088	3050	.258	14300
LC-212	.262		.104	.080	3050	.303	14300
LC-225	.262	.114	.088	3050	.258	13500	
LC-237	.262	.114	.088	3050	.258	12800	
LC-250	.262	.114	.088	3050	.258	12000	
LC-262	.262	.114	.088	3050	.258	11300	
LC-275	.323	± .008	.143	.110	4300	.309	10500
LC-287	.323		.143	.110	4300	.309	9800
LC-300	.329		.143	.110	4300	.309	9000
LC-325	.325		.144	.111	4300	.309	7500
LC-337	.395		.182	.140	5950	.345	6800

LARGER SIZES MAY BE AVAILABLE UPON REQUEST.

HARDNESS RANGES: STAINLESS STEEL RINGS (PH 15-7MO)

RING TYPE	SIZE RANGE	SCALE	ROCKWELL HARDNESS
LC	All	C	44-51

HARDNESS RANGES: BERYLLIUM COPPER RINGS

RING TYPE	SIZE RANGE	SCALE	ROCKWELL HARDNESS
LC	46-62	30N	56.5-62
	66 & over	C	37-43

HARDNESS RANGES: CARBON STEEL RINGS (SAE 1060-1090)

RING TYPE	SIZE RANGE	SCALE	ROCKWELL HARDNESS
LC	46-62	30N	65.5-70.5
	66 & over	C	47-52





# PO/POL Shaft Rings

## Radially Assembled, External Poodle

The PO ring features wide "ears" (resembling those of a poodle dog, thus the name) which offer extra retention surface against the retained part. PO rings also come in thinner sizes as a standard series of rings known as POL.

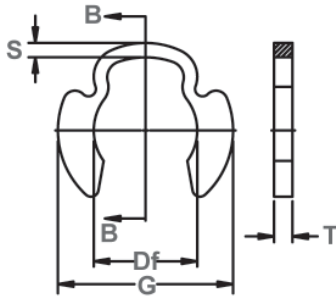

Free Diameter & Ring Measurements  
With Section B-B

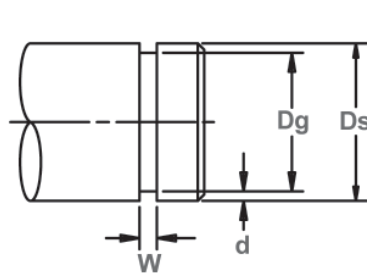

Shaft Diameter &  
Groove Dimensions

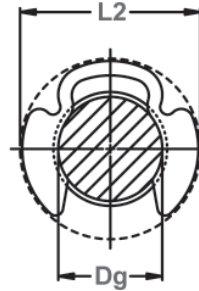

Clearance Diameter  
Installed In Groove

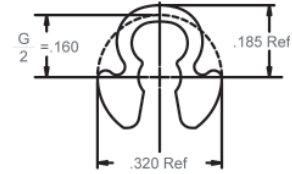

PO-15 & POL-15  
Only\*\*

RING NO.	SHAFT DIAMETER			GROOVE SIZE						RING SIZE & WEIGHT				CLR. DIA. Installed in groove	i THRUST LD. (lbs.) Sqr. Corner Abutment		
				DIAMETER		WIDTH	DEPTH	FREE DIAMETER	THICKNESS***		Weight Per 1000 Pcs.	Pr	Pg				
	Ds DEC	Ds FRACT	Ds mm	Dg	Tol.	F.I.M*	W	Tol.	d ref.	Df				Tol.	T	Tol.	lbs.
PO-15	.156	5/32	4.0	.120	±.004	.002	.039			.018	.110		.035	.42	.39	457	110
PO-18	.188	3/16	4.8	.148	±.005	.002	.039			.020	.140	±.003	.035	.63	.42	609	130
PO-25	.250	1/4	6.4	.210		.003	.039			.020	.188		.035	.84	.52	914	200
PO-31	.312	5/16	7.9	.272	±.006	.003	.046	+ .006		.020	.250		.042	1.46	.63	1320	250
PO-37	.375	3/8	9.5	.331		.003	.046			.022	.312		.042	1.92	.72	1573	300
PO-43	.438	7/16	11.1	.390		.003	.056			.024	.375	±.004	.050	2.66	.79	2233	400
PO-50	.500	1/2	12.7	.440	±.008	.004	.056			.030	.406		.050	3.30	.89	2538	600
PO-62	.625	5/8	15.9	.531		.004	.056			.047	.500	±.005	.050	4.65	1.03	3045	1100
PO-75	.750	3/4	19.0	.632		.004	.068			.059	.594		.062	6.35	1.17	4669	1600
PO-100	1.000	1	25.4	.860	±.010	.004	.086	+ .008		.070	.812	±.006	.078	12.65	1.51	7613	2600
PO-125	1.250	1 -1/4	31.8	1.090		.006	.103			.080	1.032		.093	25.20	1.90	11165	3500
PO-150	1.500	1 -1/2	38.1	1.317		.008	.120			.091	1.250	±.008	.109	36.3	2.18	15530	4800
PO-175	1.750	1-3/4	44.4	1.480	±.015	.010	.139	+ .010		.135	1.406	±.010	.125	53.0	2.45	20808	8200
PO-200	2.000	2	50.8	1.730		.012	.139			.135	1.625	±.015	.125	69.2	2.83	23853	9450
POL-15	.156	5/32	4.0	.120	±.004	.002	.029			.018	.110		.025	.30	.39	325	110
POL-18	.188	3/16	4.8	.148	±.005	.002	.029			.020	.140		.025	.45	.42	436	130
POL-25	.250	1/4	6.4	.210		.003	.029			.020	.188		.025	.60	.52	650	200
POL-31	.312	5/16	7.9	.272	±.006	.003	.029	+ .006		.020	.250	±.003	.025	.87	.63	792	250
POL-37	.375	3/8	9.5	.331		.003	.039			.022	.312		.035	1.60	.72	1320	300
POL-43	.438	7/16	11.1	.390		.003	.039			.024	.375	±.004	.035	1.86	.79	1878	400
POL-50	.500	1/2	12.7	.440	±.008	.004	.046			.030	.406		.042	2.77	.89	2132	600
POL-62	.625	5/8	15.9	.531		.004	.046			.047	.500	±.005	.042	3.65	1.03	2538	1100
POL-75	.750	3/4	19.0	.632	±.010	.004	.056	+ .008		.059	.594		.050	5.35	1.17	3756	1600
POL-100	1.000	1	25.4	.860		.004	.056			.070	.812	±.006	.050	8.60	1.51	4872	2600

\*F.I.M. (FULL INDICATOR MOVEMENT)- MAXIMUM ALLOWABLE DEVIATION OF CONCENTRICITY BETWEEN GROOVE AND SHAFT.

i BASED ON HOUSINGS/SHAFTS MADE OF COLD ROLLED STEEL. FOR AN EXPLANATION OF FORMULAS USED TO DERIVE THRUST LOAD AND OTHER PERFORMANCE DATA, CONTACT THE ROTOR CLIP ENGINEERING DEPARTMENT.

\*\*\*FOR PLATED RINGS, ADD .002" TO THE LISTED MAXIMUM THICKNESS. MAXIMUM RING THICKNESS WILL BE A MINIMUM OF .0002" LESS THAN THE LISTED GROOVE WIDTH (W) MINIMUM.

NOTE: THIS GROUP CONTAINS ALTERNATE THICKNESS VALUES (COLUMN "T"). OTHER PARAMETERS SUCH AS WIDTH OF GROOVE ("W") AND THRUST LOAD "Pr" ALSO DIFFER FROM STANDARD VERSIONS. PLEASE TAKE THIS INTO CONSIDERATION WHEN SELECTING A PO RING FOR YOUR DESIGN.

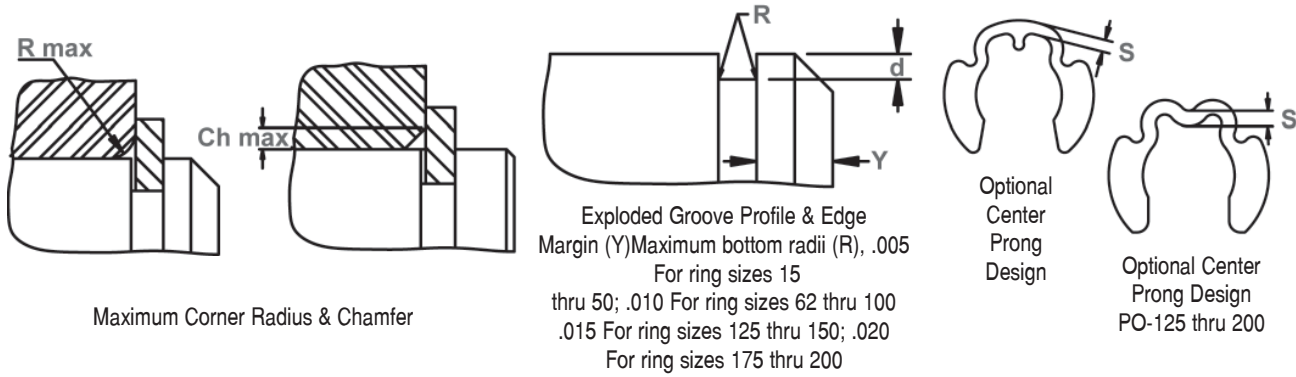

RING NO.	OUTSIDE DIA.	LARGE SECT.	ALLOWABLE CORNER RADII & CHAMFERS		MAX LOAD W/ R max or Ch max in (lbs.)	EDGE MARGIN	R.P.M. LIMITS Steel Rings
			G ref.	S			
PO-15	**	.042	.050	.040	250	.036	80000
PO-18	.400	.048	.050	.040	270	.040	80000
PO-25	.482	.058	.050	.040	310	.040	65000
PO-31	.588	.074	.065	.050	400	.040	65000
PO-37	.680	.081	.065	.050	430	.044	65000
PO-43	.752	.081	.080	.060	600	.048	60000
PO-50	.826	.097	.080	.060	630	.060	50000
PO-62	.966	.086	.080	.060	720	.094	45000
PO-75	1.095	.095	.085	.065	1000	.118	38000
PO-100	1.415	.113	.090	.065	1800	.140	25000
PO-125	1.800	.180	.090	.065	2750	.160	11000
PO-150	2.050	.208	.10	.07	3800	.182	9000
PO-175	2.300	.235	.12	.09	5100	.270	7000
PO-200	2.650	.250	.13	.10	5100	.270	5000
POL-15	**	.042	.050	.040	130	.036	80000
POL-18	.400	.048	.050	.040	140	.040	80000
POL-25	.482	.058	.050	.040	150	.040	65000
POL-31	.588	.074	.050	.040	150	.040	65000
POL-37	.680	.081	.065	.050	200	.044	65000
POL-43	.752	.081	.065	.050	300	.048	60000
POL-50	.826	.097	.080	.060	450	.060	50000
POL-62	.966	.086	.080	.060	500	.094	45000
POL-75	1.095	.095	.090	.070	650	.118	38000
POL-100	1.415	.113	.090	.070	740	.140	25000

LARGER SIZES MAY BE AVAILABLE UPON REQUEST.

SEE NOTE ON PREVIOUS PAGE.

HARDNESS RANGES: STAINLESS STEEL RINGS (PH 15-7M0)

RING TYPE	SIZE RANGE	SCALE	ROCKWELL HARDNESS
PO	All	C	44-51

HARDNESS RANGES: BERYLLIUM COPPER RINGS

RING TYPE	SIZE RANGE	SCALE	ROCKWELL HARDNESS
PO	15-25	30N	54-62
	31+	C	34-43

HARDNESS RANGES: CARBON STEEL RINGS (SAE 1060-1090)

RING TYPE	SIZE RANGE	SCALE	ROCKWELL HARDNESS
PO	All	C	47-53

HARDNESS RANGES: STAINLESS STEEL RINGS (PH 15-7M0)

RING TYPE	SIZE RANGE	SCALE	ROCKWELL HARDNESS
POL	15-31	30N	63-69.5
	37+	C	44-51

HARDNESS RANGES: BERYLLIUM COPPER RINGS

RING TYPE	SIZE RANGE	SCALE	ROCKWELL HARDNESS
POL	15-43	30N	54-62
	50+	C	34-43

HARDNESS RANGES: CARBON STEEL RINGS (SAE 1060-1090)

RING TYPE	SIZE RANGE	SCALE	ROCKWELL HARDNESS
POL	15-31	30N	65.5-71
	37+	C	47-53





# BE Shaft Rings

## Radially Assembled, External Bowed 'E'

Compensating for accumulated tolerances is what a BE "Bowed" retaining ring is designed to do on a shaft. Once snapped into the groove, bowed rings exert a force or a "preload" on the retained parts for the range specified.

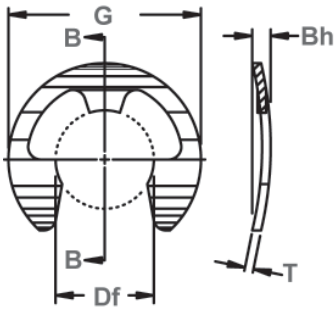

Free Diameter & Ring Measurements  
With Section B-B

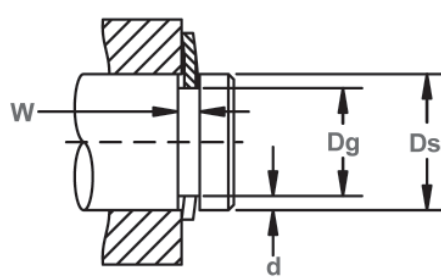

Shaft Diameter &  
Groove Dimensions

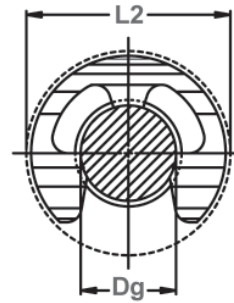

Clearance Diameter  
Installed In Groove

RING NO.	SHAFT DIAMETER			GROOVE SIZE					RING SIZE AND WEIGHT				CLEARANCE DIAMETER				
				DIAMETER		WIDTH		DEPTH	FREE DIAMETER		THICKNESS***		BOW HEIGHT		Weight Per 1000 Pcs.	Out-side dia. REF.	Installed in groove
	Ds DEC	Ds FRACT	Ds mm	Dg	Tol.	W	Tol.	d	Df	Tol.	T	Tol.	Bh min.	Bh max	lbs.	G	L2
BSE-11	.110	7/64	2.8	.079	+ .002	.022		.015	.076		.010		.025	.035	.20	.375	.390
BE-12	.125	1/8	3.2	.095	- .000	.022		.015	.094		.010	± .001	.025	.035	.06	.230	.240
BSE-14	.140	9/64	3.6	.102	.0015*	.019		.019	.100		.010		.022	.032	.040	.203	.215
BE-14	.140	9/64	3.6	.105		.025		.017	.102		.015		.028	.038	.13	.270	.285
BE-15	.156	5/32	4.0	.116		.027		.020	.114	+ .001	.015		.030	.040	.13	.282	.295
BSE-17	.172	11/64	4.4	.127	+ .002	.029		.022	.125	- .003	.015		.032	.042	.16	.312	.325
BE-18	.188	3/16	4.8	.147	- .000	.030		.020	.145		.015		.033	.043	.17	.335	.35
BSE-18	.188	3/16	4.8	.125	.002*	.035	+ .003	.031	.122		.015		.038	.048	.27	.375	.39
BSE-21	.219	7/32	5.6	.188		.040	- .000	.015	.185		.015		.043	.058	.28	.437	.45
BE-25	.250	1/4	6.3	.210		.047		.020	.207		.025		.050	.065	.76	.527	.54
BSE-31	.312	5/16	7.9	.250		.047		.031	.243	+ .002	.025	± .002	.050	.065	.57	.500	.52
BE-37	.375	3/8	9.5	.303		.060		.036	.300	- .004	.035		.060	.076	1.5	.660	.68
BE-43	.438	7/16	11.1	.343		.060		.047	.337		.035		.060	.076	1.5	.687	.71
BSE-43	.438	7/16	11.1	.380	+ .003	.057		.029	.375		.035		.060	.076	1.0	.600	.62
BE-50	.500	1/2	12.7	.396	- .000	.073		.052	.392		.042		.075	.093	2.5	.800	.82
BE-62	.625	5/8	15.9	.485	.004*	.077		.070	.480		.042		.080	.098	3.2	.940	.96
BSE-74	.744	-	18.9	.625		.085		.060	.616		.050		.090	.110	4.3	1.000	1.02
BSE-74	.750	3/4	19.0	.625		.085		.062	.616		.050		.090	.110	4.3	1.000	1.02
BE-75	.750	3/4	19.0	.580		.085		.085	.574	+ .003	.050		.090	.110	5.8	1.120	1.14
BE-87	.875	7/8	22.2	.675		.085		.100	.668	- .005	.050		.090	.110	7.6	1.300	1.32
BSE-98	.984	63/64	25	.835		.085		.074	.822		.050		.088	.112	9.38	1.500	1.530

\*F.I.M. (FULL INDICATOR MOVEMENT)-MAXIMUM ALLOWABLE DEVIATION OF CONCENTRICITY BETWEEN GROOVE AND SHAFT.

\*\*\*FOR PLATED RINGS, ADD .002" TO THE LISTED MAXIMUM THICKNESS.

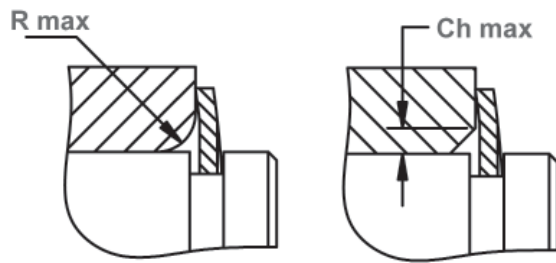

Maximum Corner Radius & Chamfer

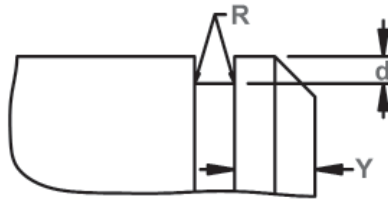

Exploded Groove Profile & Edge Margin (Y)  
Maximum bottom radii (R), .005 For ring sizes BSE-11 Thru -25; 010 For ring sizes BSE-31 Thru BSE-43; .015 For ring sizes 50 and over.

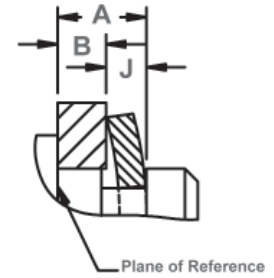

Outer Groove Wall Location  
 $A_{max} = B_{min} + J_{max}$   
 $A_{min} = B_{max} + J_{min}$

RING NO.	DISTANCE Outer groove wall to face of retained part		TAKE-UP Resilient take-up of tolerances a & b	FORCE Needed to flatten rings	ALLOWABLE CORNER RADII & CHAMFERS		MAX. LOAD w/ R max or Ch max (in lbs.)	EDGE MARGIN	R.P.M LIMITS Standard materials	THRUST LD. (lbs.) Sqr. corner abutment	
					J min	J max				J max-J min	lbs.
	BSE-11	.017	.022	.005	19	.080	.060	60	.030	35000	61
BE-12	.017	.022	.005	8	.040	.030	43	.030	35000	44	45
BSE-14	.014	.018	.004	6	.029	.022	50	.038	32000	51	60
BE-14	.020	.023	.003	16	.060	.045	75	.034	32000	76	60
BE-15	.022	.027	.005	15	.060	.045	80	.040	31000	81	75
BSE-17	.023	.029	.006	14	.060	.045	90	.044	30000	91	90
BE-18	.023	.030	.007	12	.060	.045	95	.040	30000	96	90
BSE-18	.026	.034	.008	16	.060	.045	100	.062	30000	102	135
BSE-21	.029	.039	.010	12	.060	.045	115	.030	26000	117	75
BE-25	.036	.046	.010	35	.060	.045	255	.040	25000	259	115
BSE-31	.036	.046	.010	30	.060	.045	325	.062	22000	330	225
BE-37	.045	.055	.010	55	.065	.050	690	.072	20000	700	315
BE-43	.045	.055	.010	50	.065	.050	830	.094	16500	842	480
BSE-43	.045	.055	.010	65	.050	.035	800	.058	16500	812	280
BE-50	.056	.070	.014	90	.080	.060	1110	.104	14000	1127	600
BE-62	.061	.075	.014	85	.080	.060	1420	.140	12000	1441	1050
BSE-74	.069	.085	.016	110	.057	.062	1900	.118	11000	1940	1050
BSE-74	.069	.085	.016	110	.042	.062	1900	.124	11000	1979	1100
BE-75	.069	.085	.016	110	.085	.065	2000	.170	10500	2030	1500
BE-87	.069	.085	.016	120	.085	.065	2350	.200	9000	2385	2050
BSE-98	.067	.083	.016	110	.085	.065	2700	.148	6500	2600	1750

<sup>i</sup> BASED ON HOUSINGS/SHAFTS MADE OF COLD ROLLED STEEL. FOR AN EXPLANATION OF FORMULAS USED TO DERIVE THRUST LOAD AND OTHER PERFORMANCE DATA PLEASE CONTACT THE ROTOR CLIP ENGINEERING DEPARTMENT. LARGER SIZES MAY BE AVAILABLE UPON REQUEST.

HARDNESS RANGES: STAINLESS STEEL RINGS (PH 15-7MO)

RING TYPE	SIZE RANGE	SCALE	ROCKWELL HARDNESS
BE	BE12-BSE14	15N	82.5-86*
	BSE11, BE14-BSE21	15N	82.5-86
	BE25-BSE31	30N	63-69.5
	BE37+	C	44-51

\*HARDNESS CAN NOT BE CHECKED WITH ANY DEGREE OF ACCURACY DIRECTLY ON THESE RINGS.

HARDNESS RANGES: CARBON STEEL RINGS (SAE 1060-1090)

RING TYPE	SIZE RANGE	SCALE	ROCKWELL HARDNESS
BE	BSE12-BSE14	15N	84.5-87*
	BSE11, BE14-BSE21	15N	84.5-87
	BE25-BSE31	30N	66.5-71
	BE37+	C	47-52

\*HARDNESS CAN NOT BE CHECKED WITH ANY DEGREE OF ACCURACY DIRECTLY ON THESE RINGS.

HARDNESS RANGES: BERYLLIUM COPPER RINGS

RING TYPE	SIZE RANGE	SCALE	ROCKWELL HARDNESS
BE	BE12-BSE14	15N	77-82*
	BSE11, BE14-BSE21	15N	77-82
	BE25&BSE31	30N	54-62
	BE37+	C	34-43

\*HARDNESS CAN NOT BE CHECKED WITH ANY DEGREE OF ACCURACY DIRECTLY ON THESE RINGS.





# EL Shaft Rings

## Radially Assembled, External Bowed Locking

Another variation of a bowed E ring is the EL. In addition to the bowed design for eliminating "play" in an assembly, it also features two prongs, which extend from the inner circumference to the open end locking the ring firmly into place.

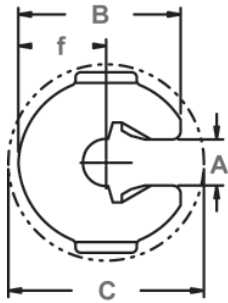

Ring Measurements

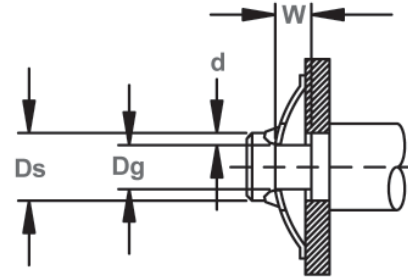

Shaft Diameter & Groove Dimensions

RING NO.	SHAFT DIAMETER			GROOVE SIZE			RING SIZE & WEIGHT						CLR. DIA.	THRUST LOAD (lbs.sq. corner abutment)						
				DIAMETER	WIDTH	DEPTH	LENGTH	THICKNESS***	BOW HEIGHT	GAP	WGHT. PER 1000 Pcs.	Released In Groove		Ring Safety Factor Of 3	Groove Safety Factor Of 3					
	DEC	Tol.	FRACT	Dg	Tol.	W	TOL.	d	B	Tol.	T	Tol.	Bh	Tol.	A	Tol.	LBS.	C	Pr	Pg
EL-9	.092		3/32	.061	±.001	.035		.016	.307		.010		.050		.063		.23	.370	80	35
EL-12	.125	±.002	1/8	.082	±.0015	.035		.021	.307		.010	±.001	.050		.086	±.004	.19	.370	102	60
EL-18	.188		3/16	.124	±.002	.045	+ .005	.032	.390	±.010	.015		.060	±.010	.130		.47	.480	203	140
EL-25	.250	±.003	1/4	.165		.055	-.000	.042	.500		.015	±.002	.070		.172	±.005	.77	.620	305	250
EL-31	.312		5/16	.228	±.003	.080		.042	.620		.015		.095		.234		1.3	.790	355	300
EL-37	.375		3/8	.270		.095		.052	.740		.020		.130		.280		2.2	.940	555	450

† BASED ON HOUSINGS/SHAFTS MADE OF COLD ROLLED STEEL. FOR AN EXPLANATION OF FORMULAS USED TO DERIVE THRUST LOAD AND OTHER PERFORMANCE DATA CONTACT THE ROTOR CLIP ENGINEERING DEPARTMENT. LARGER SIZES MAY BE AVAILABLE UPON REQUEST.

\*\*\*For plated rings, add .002" to the listed maximum thickness.

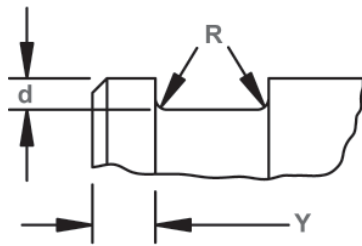

Exploded Groove Profile & Edge Margin (Y)  
Maximum bottom radii (R) .005 for ring sizes  
-9 thru -25; .010 for ring sizes -31 thru -37

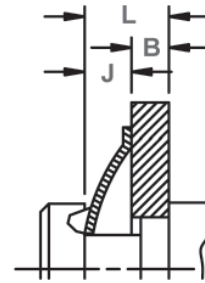

Outer Groove Wall Location  
 $L_{max} = B_{min} + J_{max}$   
 $L_{min} = B_{max} + J_{min}$

RING NO.	DISTANCE		RESILIENT TAKE-UP OF TOLERANCES OF A&B	FORCE NEEDED TO FLATTEN RINGS	APPROX. AV RESILIENT RES. (lbs) WITHIN J MAX. & J MIN		f REF.	EDGE MARGIN Y
	OUTER GROOVE WALL TO FACE OF RETAINED PART				LBS.	IN-STALLED		
	J MIN.	J MAX.	J MAX. - J MIN.					
EL-9	.030	.038	.008	30	9	3.5	.166	.031
EL-12	.030	.040	.010	30	8	3.0	.166	.043
EL-18	.039	.049	.010	60	20	5.5	.213	.064
EL-25	.045	.060	.015	60	15	7.0	.280	.085
EL-31	.070	.085	.015	60	6	4.0	.360	.084
EL-37	.080	.105	.025	80	19	7.0	.427	.105

HARDNESS RANGES: STAINLESS STEEL RINGS (PH 15-7MO)

RING TYPE	SIZE RANGE	SCALE	ROCKWELL HARDNESS
EL	9&12	15N	82.5-86*
	18-31	15N	82.5-86
	37	30N	63-69.5

HARDNESS RANGES: BERYLLIUM COPPER RINGS

RING TYPE	SIZE RANGE	SCALE	ROCKWELL HARDNESS
EL	9&12	15N	77-82*
	18-37	15N	77-82

HARDNESS RANGES: CARBON STEEL RINGS (SAE 1060-1090)

RING TYPE	SIZE RANGE	SCALE	ROCKWELL HARDNESS
EL	9&12	15N	83.5-86*
	18&25	15N	83.5-86
	31&37	30N	65-69.5

\*HARDNESS CAN NOT BE CHECKED WITH ANY DEGREE OF ACCURACY DIRECTLY ON THESE RINGS.





# SHF Shaft Rings

## External, Self-Locking Friction

The SHF ring resembles a regular SH ring except that it is designed to function on a shaft without a groove. The design of the ring causes it to exert significant gripping power uniformly on the shaft (except where the gap occurs.)

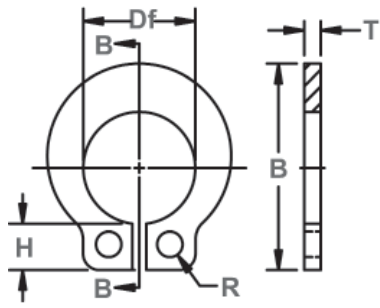

Free Diameter & Ring Measurements  
With Section B-B

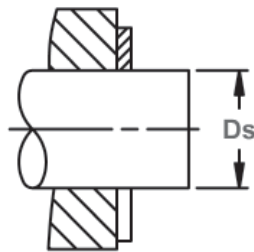

Without Groove

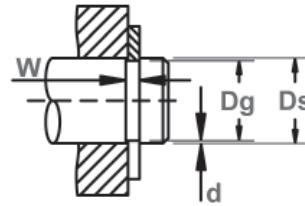

Optional Use in Groove  
(Larger Sizes)

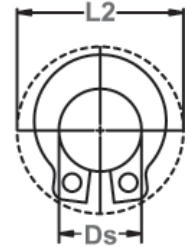

Clearance Diameter  
Expanded Over Shaft

RING NO.	SHAFT DIAMETER				GROOVE SIZE					RING SIZE & WEIGHT				CLEAR.	THRUST LD. (lbs.)								
					DIAMETER		WIDTH		DEPTH	FREE DIAMETER		THICKNESS***			Weight Per 1000 Pcs.	Re-leased over shaft	Sqr. corner abutment	Groove Safety factor of 2					
	FROM	TO	Ds FRACT	Ds mm	Dg	Tol.	W	Tol.	d	Df	Tol.	T	Tol.	L2					Pr	Pg			
SHF-6	.058	.060	-	1.5	NOT RECOMMENDED FOR USE WITH GROOVES					.065		.015		.030	.21	5	NOT RECOMMENDED FOR USE WITH GROOVES						
SHF-7	.078	.080	5/64	2.0						.074	+.002	.025		.08	.24	8							
SHF-9	.092	.096	3/32	2.4						.089	-.003	.025	±.002	.10	.26	8							
SHF-12	.123	.127	1/8	3.2						.120		.025		.24	.33	10							
SHF-15	.154	.158	5/32	4.0						.150	+.002	.025		.30	.36	12							
SHF-18	.185	.189	3/16	4.8						.181	-.004	.035		.55	.44	20							
SHF-19	.195	.199	-	5.0						.187	±.003	.032		.45	.43	30							
SHF-23	.234	.238	15/64	6.0						.228	+.0005	.041	+.003	.004	.224			.035	±.003	.76	.48	22	70
SHF-25	.248	.252	1/4	6.3						.240	-.0015	.041	-.000	.005	.238	+.002-.004		.035	±.003	.74	.49	23	90
SHF-31	.310	.316	5/16	7.9						.303		.048		.005	.298	+.003		.042		1.39	.68	25	110
SHF-37	.373	.379	3/8	9.5	.361		.048		.007	.354	-.005	.042		1.72	.74	31	180						
SHF-43	.434	.440	7/16	11.0	.419	+.001	.056	+.004	.009	.412		.050		2.61	.81	41	290						
SHF-50	.497	.503	1/2	12.7	.478	-.002	.056	-.000	.011	.470	+.004	.050		2.91	.90	46	390						
SHF-62	.622	.628	5/8	15.9	.599		.069		.013	.593	-.006	.062	±.004	5.70	1.06	61	570						
SHF-75	.745	.755	3/4	19.0	.718	+.002-.003	.069		.016	.706		.062		6.88	1.32	66	850						

† VALUES SHOWN APPLY TO RINGS INSTALLED ON A SHAFT MADE OF LOW CARBON STEEL.

FOR AN EXPLANATION OF FORMULAS USED TO DERIVE THRUST LOAD AND OTHER PERFORMANCE DATA, CONTACT THE ROTOR CLIP ENGINEERING DEPARTMENT.

\*\*\* FOR PLATED RINGS, ADD .002" TO THE LISTED MAXIMUM THICKNESS.

MAXIMUM RING THICKNESS ( WHEN USED IN GROOVE) WILL BE A MINIMUM OF .0002" LESS THAN THE LISTED GROOVE WIDTH (W) MINIMUM.



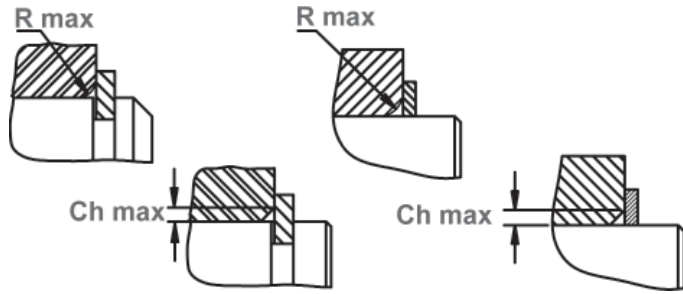

Maximum Corner Radius & Chamfer  
(With Grooves)

Maximum Corner Radius & Chamfer  
(Without Grooves)

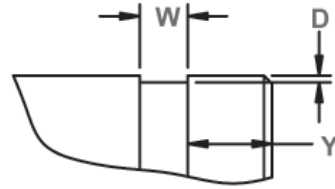

Exploded Groove Profile &  
Edge Margin (Y)



Optional Lug Design

RING NO.	ALLOWABLE CORNER RADII & CHAMFERS		EDGE MARGIN	LUG		HOLE		RING HEIGHT	R.P.M. LIMITS Standard material		
	R max	Ch max		Y	H	Tol.	R			Tol.	B
SHF-6	.025	.015	<b>NOT RECOMMENDED FOR USE WITH GROOVES</b>	.066	±.005	.035	±.004	.145	<b>OVER 80000</b>		
SHF-7	.036	.022		.071	±.003	.034		.184			
SHF-9	.042	.025		.074		.207					
SHF-12	.054	.032		.078	±.008	.042	+.010	.268			
SHF-15	.059	.035		.078		.042	-.002	.307			
SHF-18	.063	.038		.097	±.003	.051	±.004	.364			
SHF-19	.064	.039		.104		.375					
SHF-23	.070	.042		.030	.098	±.003	.051	+.010		.422	77000
SHF-25	.072	.043		.030	.097	±.004	.051	-.002		.437	58000
SHF-31	.080	.048		.030	.141		.078	+.015 -.002		.553	51000
SHF-37	.086	.051	.030	.141	.078		.620		44000		
SHF-43	.093	.056	.030	.151	.078		.701		40000		
SHF-50	.100	.060	.040	.158	.078		.768		32000		
SHF-62	.120	.072	.045	.180	.078		.948		25000		
SHF-75	.125	.075	.050	.233	.120		1.115				

LARGER SIZES MAY BE AVAILABLE UPON REQUEST.

HARDNESS RANGES: STAINLESS STEEL RINGS (PH 15-7MO)

RING TYPE	SIZE RANGE	SCALE	ROCKWELL HARDNESS
SHF	9	15N	82.5-86
	12-23	30N	63-69.5
	25+	C	44-51

HARDNESS RANGES: BERYLLIUM COPPER RINGS

RING TYPE	SIZE RANGE	SCALE	ROCKWELL HARDNESS
SHF	9	15N	77-82
	12-23	30N	54-62
	25+	C	34-43

HARDNESS RANGES: CARBON STEEL RINGS (SAE 1060-1090)

RING TYPE	SIZE RANGE	SCALE	ROCKWELL HARDNESS
SHF	6-9	15N	83.5-86
	12-23	30N	65-69.5
	25+	C	46-51



# RG Shaft Rings

## External, Self-Locking Radial Grip

The RG makes indentations on either side of the groove once installed which significantly increases its holding power. It can also be installed directly against the face of the retained part, virtually eliminating end play.  
(Note: this product works only on "soft" shafts.)

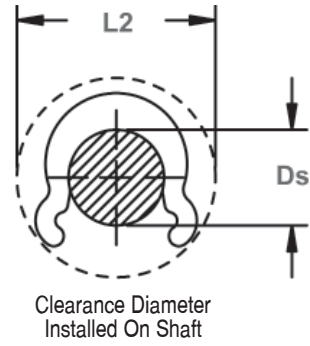
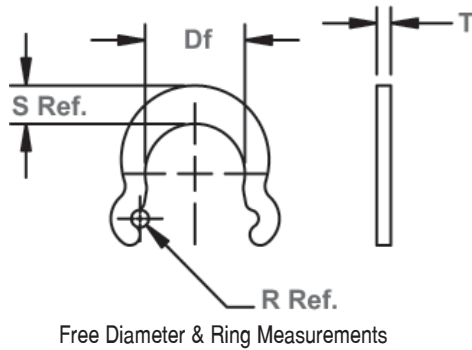

RING NO.	SHAFT DIAMETER				RING SIZE & WEIGHT						CLEARANCE Installed on shaft	THRUST LOAD Allowable load (lbs.)	RPM LIMITS Standard Material	
					FREE DIAMETER		THICKNESS***		NOTCH DIA.	MAXIMUM SECTION				Weight Per 1000 Pcs.
	FROM	TO	Ds FRACT	Ds mm	Df	Tol.	T	TOL.			R Ref.	S Ref.	lbs.	
RG-9	.092	.096	3/32	2.4	.089	+.002	.025	±.002	.040	.045	.14	.30	8	OVER 80,000
RG-12	.123	.127	1/8	3.2	.119	-.003	.025		.040	.054	.19	.34	10	
RG-15	.154	.158	5/32	4.0	.149	+.002	.025		.040	.078	.27	.38	13	
RG-18	.185	.189	3/16	4.8	.179	-.004	.035		.048	.085	.45	.44	18	
RG-25	.248	.252	1/4	6.3	.238		.035		.048	.100	.74	.54	22	
RG-31	.310	.316	5/16	7.9	.298	+.003	.042		.052	.114	1.1	.66	32	
RG-37	.373	.379	3/8	9.5	.356	-.005	.042		.052	.130	1.5	.76	42	

† VALUES SHOWN APPLY TO RINGS INSTALLED ON A SHAFT MADE OF LOW CARBON STEEL.  
FOR AN EXPLANATION OF FORMULAS USED TO DERIVE THRUST LOAD AND OTHER PERFORMANCE DATA, CONTACT THE ROTOR CLIP ENGINEERING DEPARTMENT.  
\*\*\*FOR PLATED RINGS, ADD .002" TO THE LISTED MAXIMUM THICKNESS.

HARDNESS RANGES: CARBON STEEL RINGS (SAE 1060-1090)

RING TYPE	SIZE RANGE	SCALE	ROCKWELL HARDNESS
RG	9-15	30N	65.8-70.2
	18-37	C	47-52

## External, Self-Locking Push-On (Curved Rim)

This ring features an outer rim with a series of prongs protruding into the center. The ends create interference with the shaft when the ring is installed and a load introduced to the other side. The outer rim of the TX is curved which affords greater thrust load capacity and is easier to orient for assembly than the TY ring (next page.)

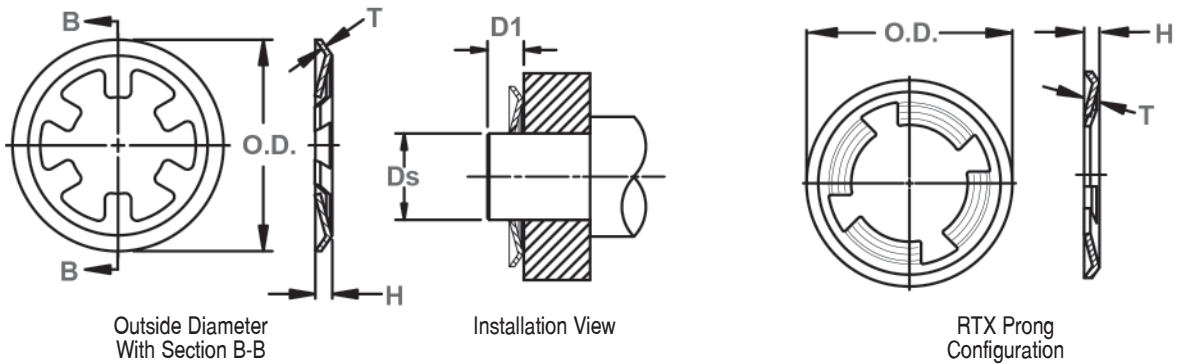

RING NO.	SHAFT DIAMETER				OUTSIDE DIAMETER		No. of prongs	*** RING HEIGHT		* THICKNESS ** Standard		i Thrust Ld. @ Std. T	Wght. Per 1000 Pcs. @ Std. T	* Thick-ness Optional	i Thrust Ld. @ Opt. T	WEIGHT Per 1000 Pcs. @ Opt. T	Min. Distance Face of part to end of shaft
	Ds DEC		Ds FRACT	Ds mm	O.D.	Tol.		H	Tol.	T	Tol.						
	FROM	TO															
TX-9	.091	.097	3/32	2.39	.326	±.005	3	.029		.010	±.001	27	.16	.015	45	.25	.058
TX-12	.121	.129	1/8	3.17	.366		4	.029	±.005	.010		39	.19	±.002	57	.30	.058
RTX-12	.121	.129	1/8	3.17	.366		2	.029		.010		100	.30	-	-	-	.058
TX-15	.152	.160	5/32	3.96	.397		4	.029		.010	46	.22	.015	70	.35	.058	
TX-18	.184	.192	3/16	4.77	.444		6	.031	±.007	.010	56	.27	±.002	85	.42	.062	
TX-25	.246	.254	1/4	6.35	.522		6	.042		.015	112	.55	.010	58	.39	.074	
TX-31	.308	.316	5/16	7.92	.584		8	.042	±.008	.015	112	.64	±.001	60	.44	.074	
TX-37	.371	.379	3/8	9.53	.645		8	.042		.015	122	.74		65	.48	.074	
RTX-37	.371	.379	3/8	9.53	.645		4	.047	±.010	.020	250	1.14	-	-	-	.074	
TX-43	.432	.442	7/16	11.1	.737		10	.045	±.009	.015	122	.96	-	-	-	.090	
TX-50	.495	.505	1/2	12.7	.828	±.010	10	.054		.015	±.002	122	1.27	-	-	-	.108
TX-56	.557	.567	9/16	14.27	.889		12	.054		.015		127	1.38	-	-	-	.108
TX-62	.620	.630	5/8	15.88	.951		12	.054	±.010	.015		137	1.47	-	-	-	.108
TX-75	.745	.755	3/4	19.05	1.076		14	.054		.015	142	1.65	-	-	-	.108	
TX-87	.870	.880	7/8	22.23	1.203		16	.054		.015	142	1.96	-	-	-	.108	
TX-100	.995	1.005	1	25.4	1.327		18	.054		.015	142	2.29	-	-	-	.108	
RTX-100	.995	1.005	1	25.4	1.327		6	.059		.020	600	3.30	-	-	-	.108	

\* FOR PLATED RINGS ADD .002" TO MAXIMUM THICKNESS AND HEIGHT.

\*\* STANDARD THICKNESS FOR STAINLESS STEEL IS AS FOLLOWS: TX-9 - TX-37, .010"; TX-43 - TX-100, .015".

\*\*\* FOR TX-9 - TX-18 OPTIONAL THICKNESS (.015"), ADD .005" TO RING HEIGHT VALUES (H) SHOWN.

FOR TX-25 - TX-37 OPTIONAL THICKNESS (.010), DEDUCT .005" FROM RING HEIGHT VALUES (H) SHOWN.

THRUST LOAD CAPACITY IF APPLICABLE TO PARTS MADE FROM CARBON SPRING STEEL AND STAINLESS STEEL MATERIALS ONLY INSTALLED ON LOW CARBON STEEL SHAFTS WITHIN THE LISTED DIA. RANGE.

HARDNESS RANGES: STAINLESS STEEL RINGS (PH 15-7MO)

RING TYPE	SIZE RANGE	SCALE	ROCKWELL HARDNESS
TX	All .010 Thick Rings	15N	82.5-86*
	All .015 Thick Rings	15N	82.5-86

HARDNESS RANGES: BERYLLIUM COPPER RINGS

RING TYPE	SIZE RANGE	SCALE	ROCKWELL HARDNESS
TX	All .010 Thick Rings	15N	77-82*
	All .015 Thick Rings	15N	77-82

HARDNESS RANGES: CARBON STEEL RINGS (SAE 1060-1090)

RING TYPE	SIZE RANGE	SCALE	ROCKWELL HARDNESS
TX	All .010 Thick Rings	15N	84-86*
	All .015 Thick Rings	15N	84-86

\*HARDNESS CAN NOT BE CHECKED WITH ANY DEGREE OF ACCURACY DIRECTLY ON THESE RINGS.





# TY Shaft Rings

## External, Self-Locking Push-On (Flat Rim)

This ring features an outer rim with a series of prongs protruding into the center. The ends create interference with the shaft when the ring is installed and a load introduced to the other side. The outer rim of the TY is flat.

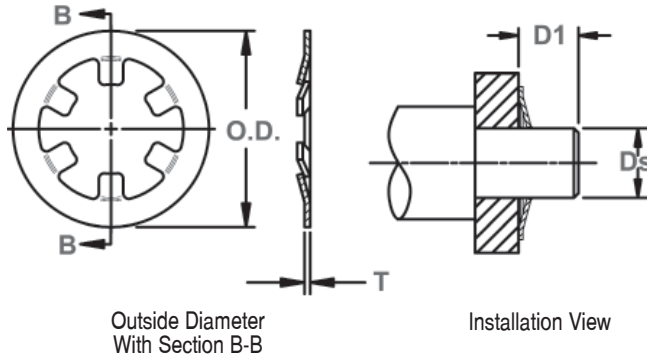

RING NO.	SHAFT DIAMETER				OUTSIDE DIAMETER		No. Of Prongs	THICKNESS*		i Thrust Load	WEIGHT Per 1000 Pcs.	Min. Distance Face of part to end of shaft		
	Ds DEC-DEZ		Ds FRACT	Ds mm	O.D.	Tol.		T	Tol.					
	FROM	TO											lbs.	lbs.
TY-9	.093	.095	3/32	2.39	.250	±.005	3	.010	±.001	13	.09	.040		
TY-12	.124	.126	1/8	3.17	.325		4			20	.14	.040		
TY-15	.155	.157	5/32	3.96	.356		4			25	.17	.040		
TY-18	.187	.189	3/16	4.77	.387		6			35	.20	.040		
TY-21	.218	.220	7/32	5.56	.418		6			35	.21	.040		
TY-24	.239	.241	-	6.10	.460		6			.015	±.002	40	.35	.060
TY-25	.249	.251	1/4	6.35	.450		6			40	.23	.040		
TY-31	.311	.313	5/16	7.92	.512		6			.010	±.001	45	.26	.040
TY-37	.374	.376	3/8	9.53	.575		6			45	.27	.040		
TY-43	.437	.439	7/16	11.1	.638		6			50	.47	.060		
TY-50	.498	.502	1/2	12.7	.750	6	±.010	.015	±.002	50	.72	.060		
TY-56	.560	.564	9/16	14.27	.812	6				50	.75	.060		
TY-62	.623	.627	5/8	15.88	.875	7				50	.82	.060		
TY-75	.748	.752	3/4	19.05	1.000	8				55	.97	.060		
TY-87	.873	.877	7/8	22.23	1.125	10				60	1.1	.060		
TY-100	.998	1.002	1	25.4	1.250	10				65	1.2	.060		

\* FOR PLATED RINGS ADD .002" TO MAXIMUM THICKNESS.  
LARGER SIZES MAY BE AVAILABLE UPON REQUEST.

i BASED ON HOUSINGS/SHAFTS MADE OF COLD ROLLED STEEL. FOR AN EXPLANATION OF FORMULAS USED TO DERIVE THRUST LOAD AND OTHER PERFORMANCE DATA, CONTACT THE ROTOR CLIP ENGINEERING DEPT.

THRUST LOAD CAPACITY IF APPLICABLE TO PARTS MADE FROM CARBON SPRING STEEL AND STAINLESS STEEL MATERIALS ONLY INSTALLED ON LOW CARBON STEEL SHAFTS WITHIN THE LISTED DIA. RANGE.

### HARDNESS RANGES: STAINLESS STEEL RINGS (PH 15-7MO)

RING TYPE	SIZE RANGE	SCALE	ROCKWELL HARDNESS
TY	9-21,25-37	15N	82.5-86*
	24,43+	15N	82.5-86

### HARDNESS RANGES: BERYLLIUM COPPER RINGS

RING TYPE	SIZE RANGE	SCALE	ROCKWELL HARDNESS
TY	9-21,25-37	15N	77-82*
	24,43+	15N	77-82

### HARDNESS RANGES: CARBON STEEL RINGS (SAE 1060-1090)

RING TYPE	SIZE RANGE	SCALE	ROCKWELL HARDNESS
TY	9-21,25-37	15N	84-86*
	24,43+	15N	84-86

\*HARDNESS CAN NOT BE CHECKED WITH ANY DEGREE OF ACCURACY DIRECTLY ON THESE RINGS.

## Internal, Self-Locking Push-On

The internal version of the TY featuring a series of prongs protruding outward. The ends create interference with the housing when the ring is installed and a load introduced to the other side.

# TI Housing Rings

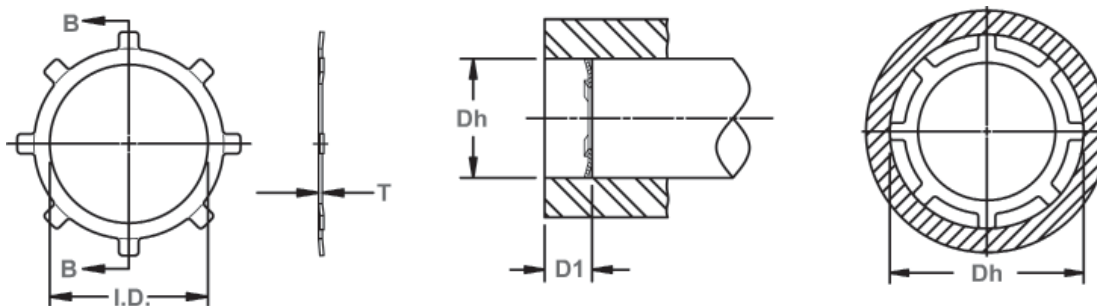

Inside Diameter With Section B-B

Housing Diameter

RING NO.	HOUSING DIAMETER				RING SIZE & WEIGHT						Min. Distance Face of part to end of housing D1				
	Dh DEC		Dh FRACT	Dh mm	INSIDE DIAMETER		THICKNESS***		No. of Prongs	Thrust Load lbs.		Weight Per 1000 Pcs. lbs.			
	FROM	TO			I.D.	Tol.	T	Tol.							
TI-31	.311	.313	5/16	7.92	.136	±.005	.010	±.001	6	81	.11	.040			
TI-37	.374	.376	3/8	9.53	.175				6	76	.16	.040			
TI-43	.437	.439	7/16	11.13	.237				6	71	.20	.040			
TI-44	.440	.442	-	11.20	.258				6	41	.18	.040			
TI-50	.498	.502	1/2	12.7	.258				6	61	.24	.040			
TI-56	.560	.564	9/16	14.27	.312				6	51	.29	.040			
TI-62	.623	.627	5/8	15.85	.390				6	46	.30	.040			
TI-63	.638	.640	-	16.23	.390				6	43	.32	.040			
TI-75	.748	.752	3/4	19.05	.500				±.010	.015	±.002	8	76	.62	.060
TI-87	.873	.877	7/8	22.23	.625							8	71	.75	.060
TI-93	.936	.940	15/16	23.83	.687	10	71	.85				.060			
TI-100	.998	1.002	1	25.4	.750	10	75	.91				.060			
TI-112	1.123	1.127	1 1/8	28.58	.813	10	60	1.30				.060			
TI-125	1.248	1.252	1 1/4	31.75	.938	10	60	1.50				.060			
TI-143	1.436	1.44	1 7/16	36.51	1.117	12	60	1.73				.060			
TI-150	1.498	1.502	1 1/2	38.10	1.188	12	60	1.80				.060			
TI-175	1.748	1.752	1 3/4	44.45	1.438	12	55	2.10				.060			
TI-200	1.998	2.002	2	50.80	1.600	14	55	3.00				.060			

\*\*\* FOR PLATED RINGS ADD .002" TO MAXIMUM THICKNESS.

LARGER SIZES MAY BE AVAILABLE UPON REQUEST.

i BASED ON HOUSINGS/SHAFTS MADE OF COLD ROLLED STEEL. FOR AN EXPLANATION OF FORMULAS USED TO DERIVE THRUST LOAD AND OTHER PERFORMANCE DATA, CONTACT THE ROTOR CLIP ENGINEERING DEPT.

THRUST LOAD CAPACITY IF APPLICABLE TO PARTS MADE FROM CARBON SPRING STEEL AND STAINLESS STEEL MATERIALS ONLY INSTALLED ON LOW CARBON STEEL SHAFTS WITHIN THE LISTED DIA. RANGE.

## PLUNGER

For Fast, Easy Installation  
Of Rotor Clip TX, TY Rings.

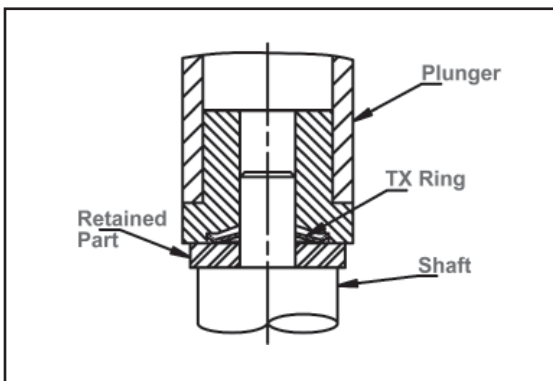

A cylindrical plunger can be easily made to install TX, TY rings. The ring is positioned at the opening of the plunger and then pushed or tapped onto the shaft, as illustrated.

HARDNESS RANGES: STAINLESS STEEL RINGS (PH 15-7MO)

RING TYPE	SIZE RANGE	SCALE	ROCKWELL HARDNESS
TI	31-62	15N	82.5-86*
	75+	15N	82.5-86

HARDNESS RANGES: BERYLLIUM COPPER RINGS

RING TYPE	SIZE RANGE	SCALE	ROCKWELL HARDNESS
TI	31-62	15N	77-82*
	75+	15N	77-82

HARDNESS RANGES: CARBON STEEL RINGS (SAE 1060-1090)

RING TYPE	SIZE RANGE	SCALE	ROCKWELL HARDNESS
TI	31-62	15N	84-86*
	75+	15N	84-86

\*HARDNESS CAN NOT BE CHECKED WITH ANY DEGREE OF ACCURACY DIRECTLY ON THESE RINGS.





# DHO Housing Rings

(DIN 472)

**Axially Assembled, Internal, Metric**  
 Once installed in the groove of a housing/bore, the portion of the ring protruding from the groove (also called a "shoulder") holds an assembly in place.

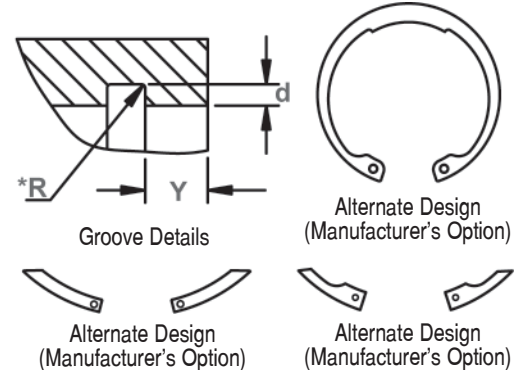
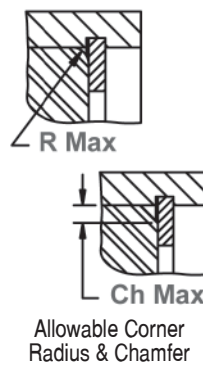
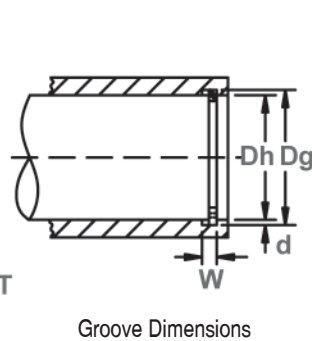
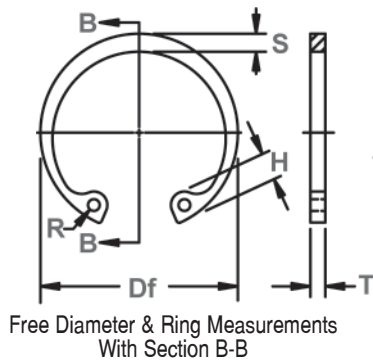

RING NO.	HOUSING		GROOVE SIZE				RINGS SIZE & WEIGHT						SUPPLEMENTARY DATA					
	Dia. (mm)	Dh	Dg	WIDTH	DEPTH	THICKNESS ***		FREE DIAMETER		LUG HT.	MAX. SEC.	HOLE DIA.	WEIGHT	EDGE MARGIN	THRUST LOAD Ring	THRUST LOAD Groove	Allowable Rad./ Cham.	Max. load w/ R /Ch Max.
						Tol.	W Min.	d	T									
DHO-8	8	8,4	+0,09	0,90	0,20	0,80	-0,05	8,7		2,4	1,1	1,0	0,10	0,6	2,0	0,86	0,5	1,5
DHO-9	9	9,4		0,90	0,20	0,80		9,8		2,5	1,3	1,0	0,13	0,6	2,0	0,96	0,5	1,5
DHO-10	10	10,4		1,10	0,20	1,00		10,8		3,2	1,4	1,2	0,26	0,6	4,0	1,08	0,5	2,2
DHO-11	11	11,4		1,10	0,20	1,00		11,8	+0,36	3,3	1,5	1,2	0,31	0,6	4,0	1,17	0,5	2,3
DHO-12	12	12,5		1,10	0,25	1,00		13,0	-0,10	3,4	1,7	1,5	0,37	0,8	4,0	1,60	0,5	2,3
DHO-13	13	13,6	+0,11	1,10	0,30	1,00		14,1		3,6	1,8	1,5	0,42	0,9	4,2	2,10	0,5	2,3
DHO-14	14	14,6		1,10	0,30	1,00		15,1		3,7	1,8	1,7	0,52	0,9	4,5	2,25	0,5	2,3
DHO-15	15	15,7		1,10	0,35	1,00		16,2		3,7	2,0	1,7	0,56	1,1	5,0	2,80	0,5	2,3
DHO-16	16	16,8		1,10	0,40	1,00		17,3		3,8	2,0	1,7	0,60	1,2	5,5	3,40	1,0	2,6
DHO-17	17	17,8		1,10	0,40	1,00		18,3		3,9	2,1	1,7	0,65	1,2	6,0	3,60	1,0	2,5
DHO-18	18	19,0		1,10	0,50	1,00		19,5		4,1	2,2	2,0	0,74	1,5	6,5	4,80	1,0	2,6
DHO-19	19	20,0		1,10	0,50	1,00		20,5		4,1	2,2	2,0	0,83	1,5	6,8	5,10	1,0	2,6
DHO-20	20	21,0	+0,13	1,10	0,50	1,00		21,5	+0,42	4,2	2,3	2,0	0,90	1,5	7,2	5,40	1,0	2,6
DHO-21	21	22,0		1,10	0,50	1,00		22,5	-0,13	4,2	2,4	2,0	1,00	1,5	7,6	5,70	1,0	2,6
DHO-22	22	23,0		1,10	0,50	1,00		23,5		4,2	2,5	2,0	1,10	1,5	8,0	5,90	1,0	2,7
DHO-23	23	24,1		1,30	0,55	1,20		24,6		4,2	2,5	2,0	1,34	1,7	8,0	6,80	1,0	4,6
DHO-24	24	25,2		1,30	0,60	1,20	-0,06	25,9		4,4	2,6	2,0	1,42	1,8	13,9	7,70	1,0	4,6
DHO-25	25	26,2		1,30	0,60	1,20		26,9	+0,42	4,5	2,7	2,0	1,50	1,8	14,6	8,00	1,0	4,7
DHO-26	26	27,2	+0,21	1,30	0,60	1,20		27,9	-0,21	4,7	2,8	2,0	1,60	1,8	13,8	8,40	1,0	4,6
DHO-27	27	28,4		1,30	0,70	1,20		29,1		4,7	2,9	2,0	1,75	2,1	13,3	10,10	1,0	4,5
DHO-28	28	29,4		1,30	0,70	1,20		30,1		4,8	2,9	2,0	1,80	2,1	13,3	10,50	1,0	4,5
DHO-29	29	30,4		1,30	0,70	1,20		31,1		4,8	3,0	2,0	1,88	2,1	13,6	10,90	1,0	4,6
DHO-30	30	31,4		1,30	0,70	1,20		32,1		4,8	3,0	2,0	2,06	2,1	13,7	11,30	1,0	4,6
DHO-31	31	32,7		1,30	0,85	1,20		33,4		5,2	3,1	2,5	2,10	2,6	13,8	14,10	1,0	4,7
DHO-32	32	33,7		1,30	0,85	1,20		34,4	+0,50	5,4	3,2	2,5	2,21	2,6	13,8	14,60	1,0	4,7
DHO-33	33	34,7	+0,25	1,30	0,85	1,20		35,5	-0,25	5,4	3,3	2,5	2,40	2,6	14,3	15,00	1,0	4,9
DHO-34	34	35,7		1,60	1,00	1,50		36,5		5,4	3,3	2,5	3,20	2,6	26,2	15,40	1,5	6,3
DHO-35	35	37,0		1,60	1,00	1,50		37,8		5,4	3,4	2,5	3,54	3,0	26,9	18,80	1,5	6,4
DHO-36	36	38,0		1,60	1,00	1,50		38,8		5,4	3,5	2,5	3,70	3,0	26,4	19,40	1,5	6,4
DHO-37	37	39,0		1,60	1,00	1,50		39,8		5,5	3,6	2,5	3,74	3,0	27,1	19,80	1,5	6,5
DHO-38	38	40,0		1,60	1,00	1,50		40,8		5,5	3,7	2,5	3,90	3,0	28,2	22,50	1,5	6,7

ALL DIMENSIONS IN MILLIMETERS.

\*The radius "R" on the load side must not exceed 0.1 T.

\*\*\* FOR PLATED RINGS, ADD 0.05 TO THE LISTED MAXIMUM THICKNESS. MAXIMUM RING THICKNESS WILL BE A MINIMUM OF 0.005 LESS THAN THE LISTED GROOVE WIDTH (W) MINIMUM.

FOR HARDNESS SPECIFICATIONS, SEE END OF THIS SECTION.

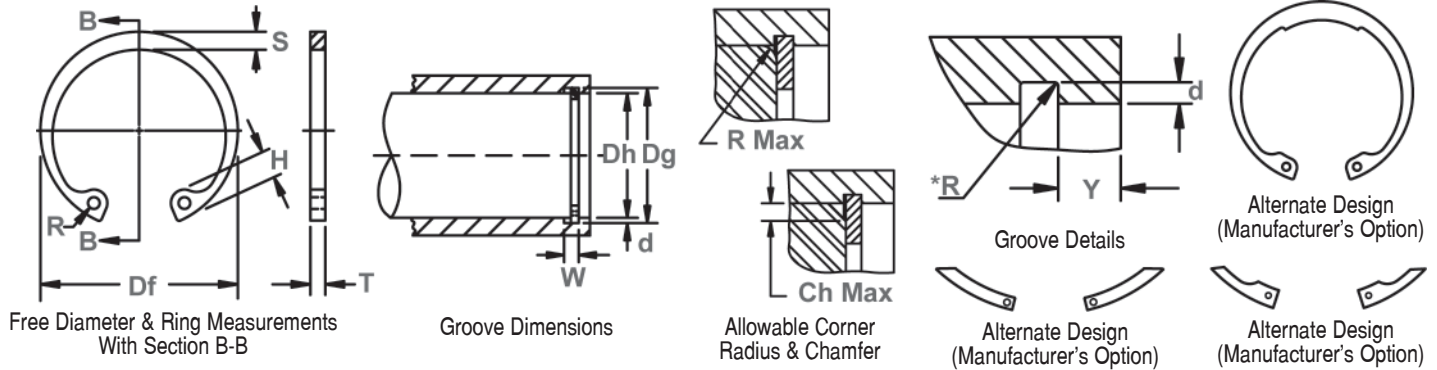

RING NO.	HOUSING Dia. (mm)	GROOVE SIZE						RINGS SIZE & WEIGHT						SUPPLEMENTARY DATA						
		DIAMETER		WIDTH	DEPTH		THICKNESS ***		FREE DIAMETER		LUG HT.	MAX. SEC.	HOLE DIA.		WEIGHT	EDGE MARGIN	THRUST LOAD Ring	THRUST LOAD Groove	Allowable Rad./Cham.	Max. load w/ R/Ch Max.
		Dh	Dg	Tol.	W Min.	d	T	Tol.	Df	Tol.	H Max.	S Ref.	R Min.	kg/1000	Y Min.	Pr kN	Pg kN	R/Ch Max.	P'r kN	
DHO-39	39	41,0		1,60	1,00	1,50		42,0		5,6	3,8	2,5	4,00	3,0	28,8	26,00	1,5	6,9		
DHO-40	40	42,5		1,85	1,25	1,75		43,5		5,8	3,9	2,5	4,70	3,8	44,6	27,00	2,0	8,3		
DHO-41	41	43,5		1,85	1,25	1,75		44,5		5,9	4,0	2,5	5,10	3,8	45,0	27,60	2,0	8,3		
DHO-42	42	44,5		1,85	1,25	1,75		45,5	+0,90	5,9	4,1	2,5	5,40	3,8	44,7	28,40	2,0	8,4		
DHO-43	43	45,5	+0,25	1,85	1,25	1,75	-0,06	46,5	-0,39	5,9	4,2	2,5	5,60	3,8	44,5	28,80	2,0	8,4		
DHO-44	44	46,5		1,85	1,25	1,75		47,5		6,0	4,2	2,5	5,80	3,8	43,3	29,50	2,0	8,3		
DHO-45	45	47,5		1,85	1,25	1,75		48,5		6,2	4,3	2,5	6,00	3,8	43,1	30,20	2,0	8,2		
DHO-46	46	48,5		1,85	1,25	1,75		49,5		6,3	4,4	2,5	6,05	3,8	42,9	30,80	2,0	8,2		
DHO-47	47	49,5		1,85	1,25	1,75		50,5		6,4	4,4	2,5	6,10	3,8	43,5	31,40	2,0	8,3		
DHO-48	48	50,5		1,85	1,25	1,75		51,5	+1,10	6,4	4,5	2,5	6,70	3,8	43,2	32,00	2,0	8,4		
DHO-50	50	53,0	+0,30	2,15	1,50	2,00		54,2	-0,46	6,5	4,6	2,5	7,30	4,5	60,8	40,50	2,0	12,1		
DHO-51	51	54,0		2,15	1,50	2,00		55,2		6,5	4,7	2,5	7,75	4,5	60,2	41,20	2,0	12,0		
DHO-52	52	55,0		2,15	1,50	2,00		56,2		6,7	4,7	2,5	8,20	4,5	60,2	42,00	2,0	12,0		
DHO-53	53	56,0		2,15	1,50	2,00		57,2		6,7	4,9	2,5	8,22	4,5	60,7	42,90	2,0	12,1		
DHO-54	54	57,0		2,15	1,50	2,00		58,2		6,7	5,0	2,5	8,25	4,5	60,4	43,60	2,0	12,3		
DHO-55	55	58,0		2,15	1,50	2,00		59,2		6,8	5,0	2,5	8,30	4,5	60,3	44,40	2,0	12,5		
DHO-56	56	59,0		2,15	1,50	2,00		60,2		6,8	5,1	2,5	8,80	4,5	60,3	45,20	2,0	12,6		
DHO-57	57	60,0		2,15	1,50	2,00		61,2		6,8	5,1	2,5	9,40	4,5	60,8	46,00	2,0	12,7		
DHO-58	58	61,0		2,15	1,50	2,00		62,2		6,9	5,2	2,5	10,50	4,5	60,8	46,70	2,0	12,7		
DHO-60	60	63,0	+0,30	2,15	1,50	2,00	-0,07	64,2	+1,10	7,3	5,4	2,5	11,10	4,5	61,0	48,30	2,0	13,0		
DHO-62	62	65,0		2,15	1,50	2,00		66,2	-0,46	7,3	5,5	2,5	11,20	4,5	60,9	49,80	2,0	13,0		
DHO-63	63	66,0		2,15	1,50	2,00		67,2		7,3	5,6	2,5	12,40	4,5	60,8	50,60	2,0	13,0		
DHO-64	64	67,0		2,15	1,50	2,00		68,2		7,4	5,7	2,5	12,45	4,5	60,6	51,40	2,0	13,0		
DHO-65	65	68,0		2,65	1,50	2,50		69,2		7,6	5,8	3,0	14,30	4,5	121	51,80	2,5	20,8		
DHO-67	67	70,0		2,65	1,50	2,50		71,5		7,7	6,0	3,0	15,30	4,5	121	53,80	2,5	21,1		
DHO-68	68	71,0		2,65	1,50	2,50		72,5		7,8	6,1	3,0	16,00	4,5	119	56,20	2,5	21,0		
DHO-70	70	73,0		2,65	1,50	2,50		74,5		7,8	6,2	3,0	16,50	4,5	119	56,20	2,5	21,0		
DHO-72	72	75,0		2,65	1,50	2,50		76,5		7,8	6,4	3,0	18,10	4,5	119	58,00	2,5	21,0		
DHO-75	75	78,0		2,65	1,50	2,50		79,5		7,8	6,6	3,0	18,80	4,5	118	60,00	2,5	21,0		
DHO-76	76	79,0		2,65	1,50	2,50		80,5		7,8	6,6	3,0	19,00	4,5	119	61,00	2,5	21,0		
DHO-78	77	80,0		2,65	1,50	2,50		82,5	+1,30	8,5	6,8	3,0	20,40	4,5	121	61,60	2,5	21,5		
DHO-78	78	81,0	+0,35	2,65	1,50	2,50		82,5	-0,54	8,5	6,8	3,0	20,40	4,5	122	62,30	2,5	21,8		
DHO-80	80	83,5		2,65	1,75	2,50		85,5		8,5	7,0	3,0	22,00	5,3	120	74,60	2,5	21,8		

ALL DIMENSIONS IN MILLIMETERS.

\*The radius "R" on the load side must not exceed 0.1 T.

\*\*\* FOR PLATED RINGS, ADD 0.05 TO THE LISTED MAXIMUM THICKNESS. MAXIMUM RING THICKNESS WILL BE A MINIMUM OF 0.005

LESS THAN THE LISTED GROOVE WIDTH (W) MINIMUM.

FOR HARDNESS SPECIFICATIONS, SEE END OF THIS SECTION.



# DHO Housing Rings

(DIN 472)

**Axially Assembled, Internal, Metric**  
 Once installed in the groove of a housing/bore, the portion of the ring protruding from the groove (also called a "shoulder") holds an assembly in place.

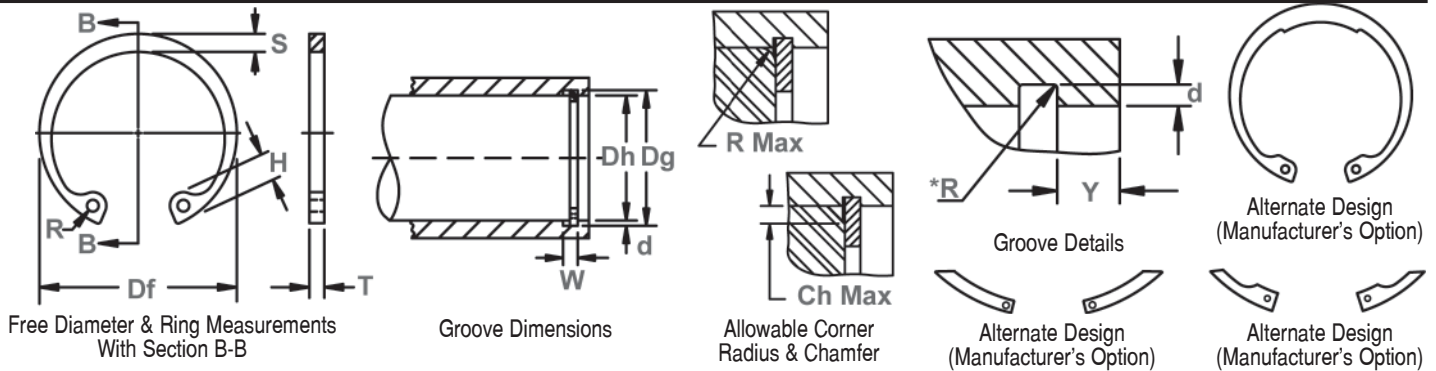

RING NO.	HOUSING Dia. (mm)	GROOVE SIZE					RINGS SIZE & WEIGHT							SUPPLEMENTARY DATA				
		DIAMETER		WIDTH	DEPTH	THICKNESS ***	FREE DIAMETER		LUG HT.	MAX. SEC.	HOLE DIA.	WEIGHT	EDGE MARGIN	THRUST LOAD Ring	THRUST LOAD Groove	Allowable Rad./ Cham.	Max. load w/ R/Ch Max.	
		Dh	Dg	Tol.	W Min.	d	T	Tol.	Df	Tol.	H Max.	S Ref.	R Min.	kg/ 1000	Y Min.	Pr kN	Pg kN	R/Ch Max.
DHO-81	81	84,5		2,65	1,75	2,50		86,5		8,5	7,0	3,0	23,00	5,3	119	75,80	2,5	21,6
DHO-82	82	85,5		2,65	1,75	2,50	-0,07	87,5		8,5	7,0	3,0	24,00	5,3	119	76,6	2,5	21,4
DHO-83	83	86,5		2,65	1,75	2,50		88,5		8,5	7,0	3,0	25,00	5,3	118	77,5	2,5	21,2
DHO-85	85	88,5		3,15	1,75	3,00		90,5		8,6	7,2	3,5	25,30	5,3	201	79,5	3,0	31,2
DHO-88	87	90,5	+0,35	3,15	1,75	3,00		93,5		8,6	7,4	3,5	31,00	5,3	204	81,3	3,0	31,8
DHO-88	88	91,5		3,15	1,75	3,00		93,5	+1,30	8,6	7,4	3,5	31,00	5,3	209	82,0	3,0	32,7
DHO-90	90	93,5		3,15	1,75	3,00	-0,08	95,5	-0,54	8,6	7,6	3,5	33,00	5,3	199	84,0	3,0	31,4
DHO-92	92	95,5		3,15	1,75	3,00		97,5		8,7	7,8	3,5	35,00	5,3	201	85,0	3,0	32,0
DHO-95	95	98,5		3,15	1,75	3,00		100,5		8,8	8,1	3,5	37,00	5,3	195	88,0	3,0	31,4
DHO-98	97	100,5		3,15	1,75	3,00		103,5		9,0	8,3	3,5	41,00	5,3	193	90,0	3,0	31,2
DHO-98	98	101,5		3,15	1,75	3,00		103,5		9,0	8,3	3,5	41,00	5,3	191	91,0	3,0	31,0
DHO-100	100	103,5		3,15	1,75	3,00		105,5		9,2	8,4	3,5	42,00	5,3	188	93,0	3,0	30,8
DHO-102	102	106,0		4,15	2,00	4,00		108,0		9,5	8,5	3,5	55,00	6,0	439	108,0	3,0	72,6
DHO-105	105	109,0		4,15	2,00	4,00		112,0		9,5	8,7	3,5	56,00	6,0	436	112,0	3,0	73,0
DHO-108	107	111,0		4,15	2,00	4,00		115,0		9,5	8,9	3,5	60,00	6,0	425	114,0	3,0	71,6
DHO-108	108	112,0	+0,54	4,15	2,00	4,00		115,0		9,5	8,9	3,5	60,00	6,0	419	115,0	3,0	71,0
DHO-110	110	114,0		4,15	2,00	4,00		117,0		10,4	9,0	3,5	64,50	6,0	415	117,0	3,0	71,0
DHO-112	112	116,0		4,15	2,00	4,00		119,0		10,5	9,1	3,5	72,00	6,0	418	119,0	3,0	72,0
DHO-115	115	119,0		4,15	2,00	4,00		122,0		10,5	9,3	3,5	74,50	6,0	409	122,0	3,0	71,2
DHO-118	117	121,0		4,15	2,00	4,00		125,0		10,7	9,6	3,5	75,50	6,0	399	124,0	3,0	70,0
DHO-118	118	122,0		4,15	2,00	4,00		125,0		10,7	9,6	3,5	75,50	6,0	394	125,0	3,0	69,3
DHO-120	120	124,0		4,15	2,00	4,00	-0,10	127,0		11,0	9,7	3,5	77,00	6,0	396	127,0	3,0	70,0
DHO-122	122	126,0		4,15	2,00	4,00		129,0		11,0	9,8	4,0	78,00	6,0	399	129,0	3,0	71,0
DHO-125	125	129,0		4,15	2,00	4,00		132,0		11,0	10,0	4,0	79,00	6,0	385	132,0	3,0	70,0
DHO-128	127	131,0	+0,63	4,15	2,00	4,00		135,0	+1,50	11,0	10,0	4,0	81,00	6,0	383	135,0	3,0	70,0
DHO-128	128	132,0		4,15	2,00	4,00		135,0	-0,63	11,0	10,2	4,0	81,00	6,0	378	136,0	3,0	69,0
DHO-130	130	134,0		4,15	2,00	4,00		137,0		11,0	10,2	4,0	82,00	6,0	374	138,0	3,0	69,0
DHO-132	132	136,0		4,15	2,00	4,00		139,0		11,0	10,3	4,0	83,00	6,0	366	140,0	3,0	68,0
DHO-135	135	139,0		4,15	2,00	4,00		142,0		11,2	10,5	4,0	84,00	6,0	358	143,0	3,0	67,0
DHO-138	137	141,0		4,15	2,00	4,00		145,0		11,2	10,6	4,0	86,00	6,0	356	145,0	3,0	67,0
DHO-138	138	142,0		4,15	2,00	4,00		145,0		11,2	10,6	4,0	86,00	6,0	352	146,0	3,0	66,5
DHO-140	140	144,0		4,15	2,00	4,00		147,0		11,2	10,7	4,0	87,50	6,0	350	148,0	3,0	66,5

ALL DIMENSIONS IN MILLIMETERS.

\*The radius "R" on the load side must not exceed 0.1 T.

\*\*\* FOR PLATED RINGS, ADD 0.05 TO THE LISTED MAXIMUM THICKNESS. MAXIMUM RING THICKNESS WILL BE A MINIMUM OF 0.005 LESS THAN THE LISTED GROOVE WIDTH (W) MINIMUM.

FOR HARDNESS SPECIFICATIONS, SEE END OF THIS SECTION.



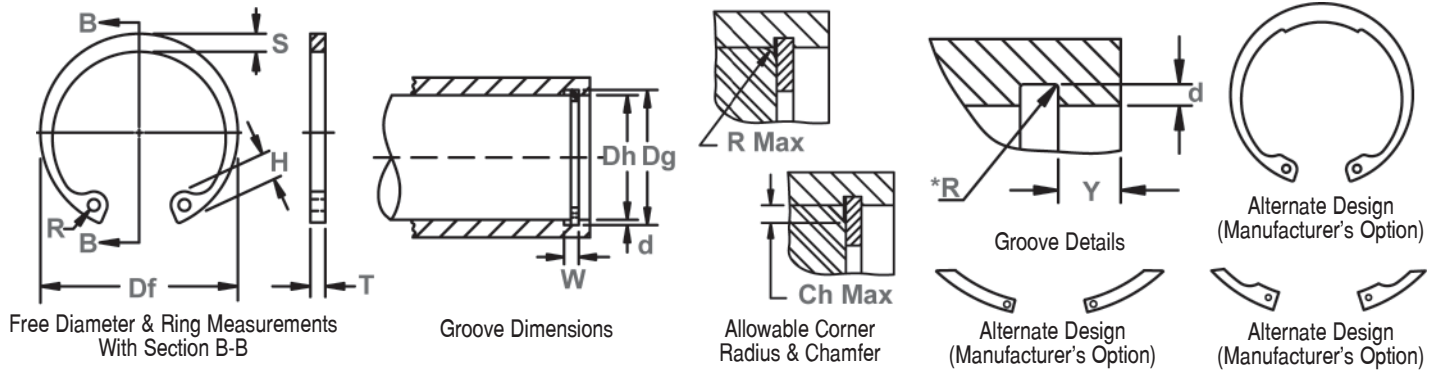

RING NO.	HOUSING Dia. (mm)	GROOVE SIZE						RINGS SIZE & WEIGHT						SUPPLEMENTARY DATA					
		DIAMETER			WIDTH	DEPTH	THICKNESS ***		FREE DIAMETER		LUG HT.	MAX. SEC.	HOLE DIA.	WEIGHT	EDGE MARGIN	THRUST LOAD Ring	THRUST LOAD Groove	Allowable Rad./Cham.	Max. load w/ R/Ch Max.
		Dh	Dg	Tol.	W Min.	d	T	Tol.	Df	Tol.	H Max.	S Ref.	R Min.	kg/1000	Y Min.	Pr kN	Pg kN	R/Ch Max.	P'r kN
DHO-142	142	146,0		4,15	2,00	4,00		149,0		11,3	10,8	4,0	89,00	6,0	342	150,0	3,0	65,5	
DHO-145	145	149,0		4,15	2,00	4,00		152,0		11,4	10,9	4,0	93,00	6,0	336	153,0	3,0	65,0	
DHO-148	147	151,0		4,15	2,00	4,00		155,0		11,8	11,1	4,0	100,0	6,0	336	156,0	3,0	65,0	
DHO-148	148	152,0		4,15	2,00	4,00		155,0		11,8	11,1	4,0	100,0	6,0	331	157,0	3,0	64,5	
DHO-150	150	155,0		4,15	2,50	4,00		158,0		12,0	11,2	4,0	105,0	7,5	326	191,0	3,0	64,0	
DHO-152	152	157,0		4,15	2,50	4,00		161,0	+1,50	12,0	11,3	4,0	106,0	7,5	326	202,0	3,5	55,0	
DHO-155	155	160,0		4,15	2,50	4,00		164,0	-0,63	12,0	11,4	4,0	107,0	7,5	324	206,0	3,5	55,0	
DHO-158	157	162,0	+0,63	4,15	2,50	4,00		167,0		12,3	11,5	4,0	109,0	7,5	328	208,0	3,5	55,5	
DHO-158	158	163,0		4,15	2,50	4,00		167,0		12,3	11,5	4,0	109,0	7,5	326	210,0	3,5	55,0	
DHO-160	160	165,0		4,15	2,50	4,00		169,0		13,0	11,6	4,0	110,0	7,5	321	212,0	3,5	54,5	
DHO-162	162	167,0		4,15	2,50	4,00		171,5		13,0	11,7	4,0	118,0	7,5	321	215,0	3,5	54,5	
DHO-165	165	170,0		4,15	2,50	4,00		174,5		13,0	11,8	4,0	125,0	7,5	319	219,0	3,5	54,0	
DHO-168	167	172,0		4,15	2,50	4,00		177,5		13,5	12,1	4,0	135,0	7,5	355	221,0	3,5	60,0	
DHO-168	168	173,0		4,15	2,50	4,00	-0,10	177,5		13,5	12,1	4,0	135,0	7,5	353	223,0	3,5	60,0	
DHO-170	170	175,0		4,15	2,50	4,00		179,5		13,5	12,2	4,0	140,0	7,5	349	225,0	3,5	59,0	
DHO-172	172	177,0		4,15	2,50	4,00		181,5		13,5	12,5	4,0	145,0	7,5	357	228,0	3,5	60,0	
DHO-175	175	180,0		4,15	2,50	4,00		184,5		13,5	12,7	4,0	150,0	7,5	351	232,0	3,5	59,0	
DHO-178	177	182,0		4,15	2,50	4,00		187,5		14,2	12,9	4,0	162,0	7,5	346	235,0	3,5	58,5	
DHO-178	178	183,0		4,15	2,50	4,00		187,5		14,2	12,9	4,0	162,0	7,5	344	236,0	3,5	58,0	
DHO-180	180	185,0		4,15	2,50	4,00		189,5		14,2	13,2	4,0	165,0	7,5	347	238,0	3,5	58,5	
DHO-182	182	187,0		4,15	2,50	4,00		191,5		14,2	13,5	4,0	168,0	7,5	355	241,0	3,5	60,0	
DHO-185	185	190,0		4,15	2,50	4,00		194,5		14,2	13,7	4,0	170,0	7,5	349	245,0	3,5	59,0	
DHO-188	187	192,0		4,15	2,50	4,00		197,5	+1,70	14,2	13,8	4,0	174,0	7,5	345	248,0	3,5	58,5	
DHO-188	188	193,0		4,15	2,50	4,00		197,5	-0,72	14,2	13,8	4,0	174,0	7,5	343	249,0	3,5	58,0	
DHO-190	190	195,0	+0,72	4,15	2,50	4,00		199,5		14,2	13,8	4,0	175,0	7,5	340	251,0	3,5	57,5	
DHO-192	192	197,0		4,15	2,50	4,00		201,5		14,2	13,8	4,0	178,0	7,5	336	254,0	3,5	57,0	
DHO-195	195	200,0		4,15	2,50	4,00		204,5		14,2	13,8	4,0	183,0	7,5	330	258,0	3,5	55,5	
DHO-198	197	202,0		4,15	2,50	4,00		207,5		14,2	14,0	4,0	190,0	7,5	330	260,0	3,5	55,5	
DHO-198	198	203,0		4,15	2,50	4,00		207,5		14,2	14,0	4,0	190,0	7,5	329	262,0	3,5	55,5	
DHO-200	200	205,0		4,15	2,50	4,00		209,5		14,2	14,0	4,0	195,0	7,5	325	265,0	3,5	55,0	
DHO-202	202	208,0		5,15	3,00	5,00		214,0		14,2	14,0	4,0	210,0	9,0	625	321,0	4,0	92,5	
DHO-205	205	211,0		5,15	3,00	5,00	-0,12	217,0		14,2	14,0	4,0	225,0	9,0	616	326,0	4,0	91,5	
DHO-205	207	213,0		5,15	3,00	5,00		217,0		14,2	14,0	4,0	225,0	9,0	610	329,0	4,0	90,0	

ALL DIMENSIONS IN MILLIMETERS.

\*The radius "R" on the load side must not exceed 0.1 T.

\*\*\* FOR PLATED RINGS, ADD 0.05 TO THE LISTED MAXIMUM THICKNESS. MAXIMUM RING THICKNESS WILL BE A MINIMUM OF 0.005 LESS THAN THE LISTED GROOVE WIDTH (W) MINIMUM.

FOR HARDNESS SPECIFICATIONS, SEE END OF THIS SECTION.



# DHO Housing Rings

(DIN 472)

**Axially Assembled, Internal, Metric**  
 Once installed in the groove of a housing/bore, the portion of the ring protruding from the groove (also called a "shoulder") holds an assembly in place.

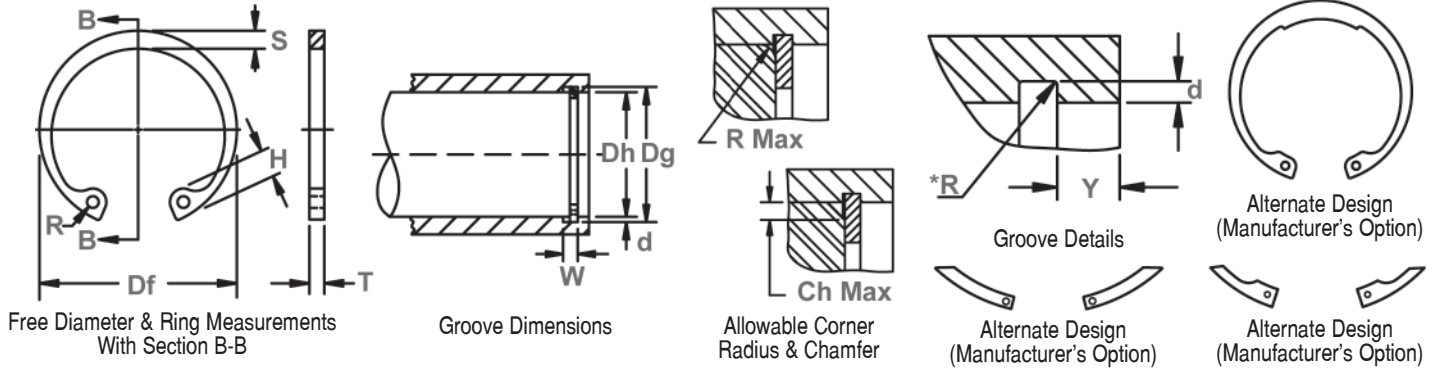

RING NO.	HOUSING Dia. (mm)		GROOVE SIZE					RINGS SIZE & WEIGHT							SUPPLEMENTARY DATA				
			DIAMETER		WIDTH	DEPTH	THICKNESS ***		FREE DIAMETER		LUG HT.	MAX. SEC.	HOLE DIA.	WEIGHT	EDGE MARGIN	THRUST LOAD Ring	THRUST LOAD Groove	Allowable Rad./Cham.	Max. load w/ R/Ch Max.
	Dh	Dg	Tol.	W Min.	d	T	Tol.	Df	Tol.	H Max.	S Ref.	R Min.	kg/1000	Y Min.	Pr kN	Pg kN	R/Ch Max.	P'r kN	
DHO-210	208	214,0		5,15	3,00	5,00		222,0		14,2	14,0	4,0	270,0	9,0	607	331,0	4,0	90,0	
DHO-210	210	216,0		5,15	3,00	5,00		222,0		14,2	14,0	4,0	270,0	9,0	601	333,0	4,0	89,5	
DHO-210	212	218,0		5,15	3,00	5,00		222,0		14,2	14,0	4,0	270,0	9,0	596	337,0	4,0	88,5	
DHO-215	215	221,0		5,15	3,00	5,00		227,0		14,2	14,0	4,0	300,0	9,0	586	341,0	4,0	87,0	
DHO-215	217	223,0		5,15	3,00	5,00		227,0		14,2	14,0	4,0	300,0	9,0	581	345,0	4,0	86,0	
DHO-220	218	224,0		5,15	3,00	5,00		232,0	+1,70	14,2	14,0	4,0	315,0	9,0	580	346,0	4,0	86,0	
DHO-220	220	226,0		5,15	3,00	5,00		232,0	-0,72	14,2	14,0	4,0	315,0	9,0	574	349,0	4,0	85,0	
DHO-220	222	228,0		5,15	3,00	5,00		232,0		14,2	14,0	4,0	315,0	9,0	568	353,0	4,0	84,0	
DHO-225	225	231,0	+0,72	5,15	3,00	5,00		237,0		14,2	14,0	4,0	323,0	9,0	560	357,0	4,0	83,0	
DHO-225	227	233,0		5,15	3,00	5,00		237,0		14,2	14,0	4,0	323,0	9,0	555	361,0	4,0	82,0	
DHO-230	228	234,0		5,15	3,00	5,00		242,0		14,2	14,0	4,0	330,0	9,0	554	362,0	4,0	82,0	
DHO-230	230	236,0		5,15	3,00	5,00		242,0		14,2	14,0	4,0	330,0	9,0	549	365,0	4,0	81,0	
DHO-230	232	238,0		5,15	3,00	5,00	-0,12	242,0		14,2	14,0	4,0	330,0	9,0	544	369,0	4,0	80,50	
DHO-235	235	241,0		5,15	3,00	5,00		247,0		14,2	14,0	4,0	338,0	9,0	536	373,0	4,0	79,50	
DHO-235	237	243,0		5,15	3,00	5,00		247,0		14,2	14,0	4,0	338,0	9,0	531	376,0	4,0	79,00	
DHO-240	238	244,0		5,15	3,00	5,00		252,0		14,2	14,0	4,0	345,0	9,0	530	378,0	4,0	79,00	
DHO-240	240	246,0		5,15	3,00	5,00		252,0		14,2	14,0	4,0	345,0	9,0	525	380,0	4,0	77,50	
DHO-240	242	248,0		5,15	3,00	5,00		252,0	+2,00	14,2	14,0	4,0	345,0	9,0	521	385,0	4,0	77,00	
DHO-245	245	251,0		5,15	3,00	5,00		257,0	-0,81	14,2	14,0	4,0	353,0	9,0	514	389,0	4,0	76,50	
DHO-245	247	253,0		5,15	3,00	5,00		257,0		14,2	14,0	4,0	353,0	9,0	509	392,0	4,0	76,00	
DHO-250	248	254,0	+0,81	5,15	3,00	5,00		262,0		14,2	14,0	4,0	360,0	9,0	507	394,0	4,0	75,50	
DHO-250	250	256,0		5,15	3,00	5,00		262,0		14,2	14,0	4,0	360,0	9,0	504	396,0	4,0	75,00	
DHO-252	252	260,0		5,15	4,00	5,00		262,0		14,2	16,0	5,0	360,0	12,0	557	535,0	4,0	83,00	
DHO-255	255	263,0		5,15	4,00	5,00		270,0		16,2	16,0	5,0	368,0	12,0	549	541,0	4,0	81,50	
DHO-255	257	265,0		5,15	4,00	5,00		270,0		16,2	16,0	5,0	368,0	12,0	545	546,0	4,0	81,00	

ALL DIMENSIONS IN MILLIMETERS.

\*The radius "R" on the load side must not exceed 0.1 T.

\*\*\* FOR PLATED RINGS, ADD 0.05 TO THE LISTED MAXIMUM THICKNESS.

MAXIMUM RING THICKNESS WILL BE A MINIMUM OF 0.005 LESS THAN THE LISTED GROOVE WIDTH (W) MINIMUM.

FOR HARDNESS SPECIFICATIONS, SEE END OF THIS SECTION.

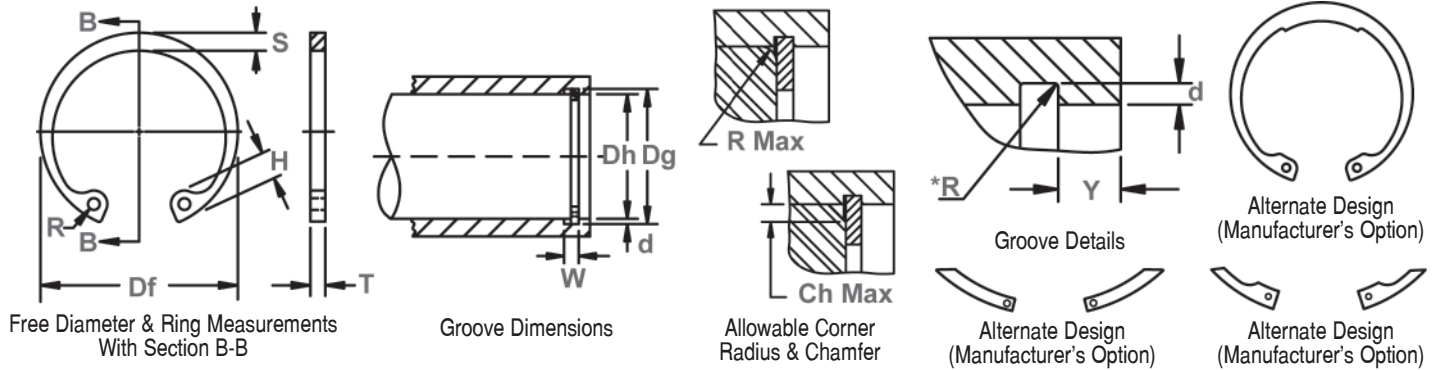

RING NO.	HOUSING Dia. (mm)	GROOVE SIZE					RINGS SIZE & WEIGHT							SUPPLEMENTARY DATA				
		DIAMETER		WIDTH	DEPTH	THICKNESS ***	FREE DIAMETER		LUG HT.	MAX. SEC.	HOLE DIA.	WEIGHT	EDGE MARGIN	THRUST LOAD Ring	THRUST LOAD Groove	Allowable Rad./ Cham.	Max. load w/ R / Ch Max.	
		Dh	Dg	Tol.	W Min.	d	T	Tol.	Df	Tol.	H Max.	S Ref.	R Min.	kg/ 1000	Y Min.	Pr kN	Pg kN	R/Ch Max.
DHO-260	258	266,0		5,15	4,00	5,00		275,0		16,2	16,0	5,0	375,0	12,0	543	548,0	4,0	80,50
DHO-260	260	268,0		5,15	4,00	5,00		275,0		16,2	16,0	5,0	375,0	12,0	538	553,0	4,0	80,00
DHO-260	262	270,0		5,15	4,00	5,00		275,0		16,2	16,0	5,0	375,0	12,0	535	556,0	4,0	79,00
DHO-265	265	273,0		5,15	4,00	5,00		280,0		16,2	16,0	5,0	383,0	12,0	528	563,0	4,0	78,50
DHO-265	267	275,0		5,15	4,00	5,00		280,0		16,2	16,0	5,0	383,0	12,0	524	566,0	4,0	78,00
DHO-270	268	276,0		5,15	4,00	5,00		285,0		16,2	16,0	5,0	388,0	12,0	522	570,0	4,0	77,50
DHO-270	270	278,0		5,15	4,00	5,00		285,0		16,2	16,0	5,0	388,0	12,0	518	573,0	4,0	77,00
DHO-270	272	280,0		5,15	4,00	5,00		285,0		16,2	16,0	5,0	388,0	12,0	515	577,0	4,0	76,50
DHO-275	275	283,0		5,15	4,00	5,00		290,0	+2,00	16,2	16,0	5,0	393,0	12,0	509	585,0	4,0	75,50
DHO-275	277	285,0	+0,81	5,15	4,00	5,00	-0,12	290,0	-0,81	16,2	16,0	5,0	393,0	12,0	505	587,0	4,0	75,00
DHO-280	278	286,0		5,15	4,00	5,00		295,0		16,2	16,0	5,0	400,0	12,0	504	590,0	4,0	75,00
DHO-280	280	288,0		5,15	4,00	5,00		295,0		16,2	16,0	5,0	400,0	12,0	499	593,0	4,0	74,00
DHO-280	282	290,0		5,15	4,00	5,00		295,0		16,2	16,0	5,0	400,0	12,0	497	599,0	4,0	74,00
DHO-285	285	293,0		5,15	4,00	5,00		300,0		16,2	16,0	5,0	408,0	12,0	491	605,0	4,0	73,00
DHO-285	287	295,0		5,15	4,00	5,00		300,0		16,2	16,0	5,0	408,0	12,0	487	610,0	4,0	72,00
DHO-290	288	296,0		5,15	4,00	5,00		305,0		16,2	16,0	5,0	415,0	12,0	485	611,0	4,0	72,00
DHO-290	290	298,0		5,15	4,00	5,00		305,0		16,2	16,0	5,0	415,0	12,0	482	615,0	4,0	71,50
DHO-290	292	300,0		5,15	4,00	5,00		305,0		16,2	16,0	5,0	415,0	12,0	479	620,0	4,0	71,00
DHO-295	295	303,0		5,15	4,00	5,00		310,0		16,2	16,0	5,0	426,0	12,0	474	625,0	4,0	70,50
DHO-295	297	305,0		5,15	4,00	5,00		310,0		16,2	16,0	5,0	426,0	12,0	471	630,0	4,0	70,50
DHO-300	298	306,0		5,15	4,00	5,00		315,0		16,2	16,0	5,0	435,0	12,0	469	631,0	4,0	69,50
DHO-300	300	308,0		5,15	4,00	5,00		315,0		16,2	16,0	5,0	435,0	12,0	466	636,0	4,0	69,00
DHO-305	305	315,0		6,20	5,00	6,00	-0,15	322,0	+2,00	16,2	20,0	6,0	755,0	15,0	961	810,0	5,0	114,00
DHO-310	310	320,0	+0,89	6,20	5,00	6,00		327,0	-0,90	20,2	20,0	6,0	770,0	15,0	947	823,0	5,0	113,00

ALL DIMENSIONS IN MILLIMETERS.  
 \*The radius "R" on the load side must not exceed 0.1 T.  
 \*\*\* FOR PLATED RINGS, ADD 0.05 TO THE LISTED MAXIMUM THICKNESS.  
 MAXIMUM RING THICKNESS WILL BE A MINIMUM OF 0.005 LESS THAN THE LISTED GROOVE WIDTH (W) MINIMUM.  
 FOR HARDNESS SPECIFICATIONS, SEE END OF THIS SECTION.



# DHO Housing Rings

(DIN 472)

**Axially Assembled, Internal, Metric**  
 Once installed in the groove of a housing/bore, the portion of the ring protruding from the groove (also called a "shoulder") holds an assembly in place.

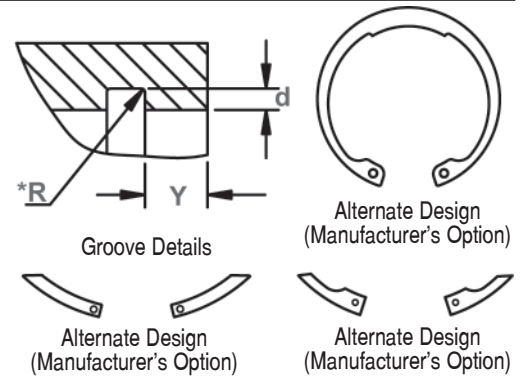
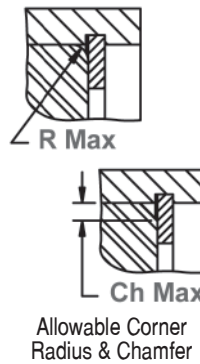
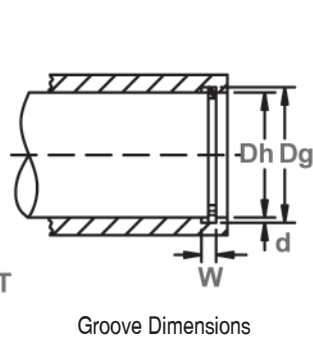
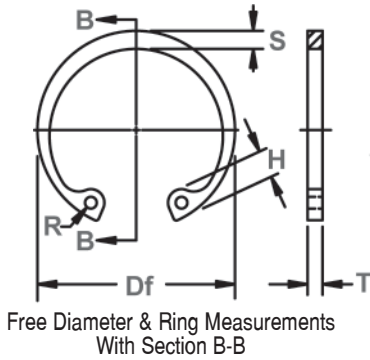

RING NO.	HOUSING Dia. (mm)		GROOVE SIZE					RINGS SIZE & WEIGHT						SUPPLEMENTARY DATA				
			DIAMETER		WIDTH	DEPTH	THICKNESS ***		FREE DIAMETER		LUG HT.	MAX. SEC.	HOLE DIA.	WEIGHT	EDGE MARGIN	THRUST LOAD Ring	THRUST LOAD Groove	Allowable Rad./Cham.
	Dh	Dg	Tol.	W Min.	d	T	Tol.	Df	Tol.	H Max.	S Ref.	R Min.	kg/1000	Y Min.	Pr kN	Pg kN	R/Ch Max.	Pr kN
DHO-315	315	325,0		6,20	5,00	6,00		332,0		20,2	20,0	6,0	785,0	15,0	934	837,0	5,0	111,00
DHO-320	320	330,0		6,20	5,00	6,00		337,0		20,2	20,0	6,0	800,0	15,0	919	850,0	5,0	109,00
DHO-325	325	335,0		6,20	5,00	6,00		342,0		20,2	20,0	6,0	810,0	15,0	906	864,0	5,0	108,00
DHO-330	330	340,0		6,20	5,00	6,00		347,0		20,2	20,0	6,0	820,0	15,0	894	876,0	5,0	106,00
DHO-335	335	345,0		6,20	5,00	6,00		352,0		20,2	20,0	6,0	830,0	15,0	880	890,0	5,0	105,00
DHO-340	340	350,0		6,20	5,00	6,00		357,0	+2,00	20,2	20,0	6,0	840,0	15,0	869	903,0	5,0	104,00
DHO-345	345	355,0		6,20	5,00	6,00		362,0	-0,90	20,2	20,0	6,0	855,0	15,0	857	916,0	5,0	102,00
DHO-350	350	360,0	+0,89	6,20	5,00	6,00		367,0		20,2	20,0	6,0	870,0	15,0	846	929,0	5,0	101,00
DHO-355	355	365,0		6,20	5,00	6,00		372,0		20,2	20,0	6,0	880,0	15,0	834	942,0	5,0	99,00
DHO-360	360	370,0		6,20	5,00	6,00		377,0		20,2	20,0	6,0	890,0	15,0	823	955,0	5,0	98,00
DHO-365	365	375,0		6,20	5,00	6,00	-0,15	382,0		20,2	20,0	6,0	906,0	15,0	813	968,0	5,0	97,00
DHO-370	370	380,0		6,20	5,00	6,00		387,0		20,2	20,0	6,0	920,0	15,0	803	981,0	5,0	95,00
DHO-375	375	385,0		6,20	5,00	6,00		392,0		20,2	20,0	6,0	932,0	15,0	793	994,0	5,0	94,00
DHO-380	380	390,0		6,20	5,00	6,00		397,0		20,2	20,0	6,0	940,0	15,0	784	1008,0	5,0	93,00
DHO-385	385	395,0		6,20	5,00	6,00		402,0		20,2	20,0	6,0	950,0	15,0	774	1021,0	5,0	92,00
DHO-390	390	400,0		6,20	5,00	6,00		407,0		20,2	20,0	6,0	960,0	15,0	764	1033,0	5,0	91,00
DHO-395	395	405,0		6,20	5,00	6,00		412,0		20,2	20,0	6,0	972,0	15,0	756	1047,0	5,0	90,00
DHO-400	400	410,0		6,20	5,00	6,00		417,0	+2,00	20,2	20,0	6,0	980,0	15,0	746	1060,0	5,0	89,00
DHO-410	410	422,0	+1,00	7,20	6,00	7,00		430,0	-1,00	26,2	26,0	6,0	1380,0	18,0	1512	1307,0	6,0	150,00
DHO-420	420	432,0		7,20	6,00	7,00		440,0		26,2	26,0	6,0	1410,0	18,0	1480	1338,0	6,0	147,00
DHO-430	430	442,0		7,20	6,00	7,00		450,0		26,2	26,0	6,0	1440,0	18,0	1446	1369,0	6,0	144,00
DHO-440	440	452,0		7,20	6,00	7,00		460,0		26,2	26,0	6,0	1470,0	18,0	1418	1401,0	6,0	141,00
DHO-450	450	462,0		7,20	6,00	7,00		470,0		26,2	26,0	6,0	1510,0	18,0	1388	1431,0	6,0	138,00
DHO-460	460	472,0		7,20	6,00	7,00		480,0		26,2	26,0	6,0	1550,0	18,0	1360	1464,0	6,0	135,00

ALL DIMENSIONS IN MILLIMETERS.

\*The radius "R" on the load side must not exceed 0.1 T.

\*\*\* FOR PLATED RINGS, ADD 0.05 TO THE LISTED MAXIMUM THICKNESS.

MAXIMUM RING THICKNESS WILL BE A MINIMUM OF 0.005 LESS THAN THE LISTED GROOVE WIDTH (W) MINIMUM.

HARDNESS RANGES: CARBON STEEL RINGS (SAE 1060-1090)

RING TYPE	SIZE RANGE	HARDNESS		
		VICKERS	ROCKWELL	
			HRC	LOWER SCALE*
DHO	8-22	470-580	47-54	66-72 HR30N
	23-48	470-580	47-54	-
	50-200	435-530	44-51	-
	202-300	390-470	40-47	-
	305-1000	370-415	38-43	-

\*WHERE APPLICABLE



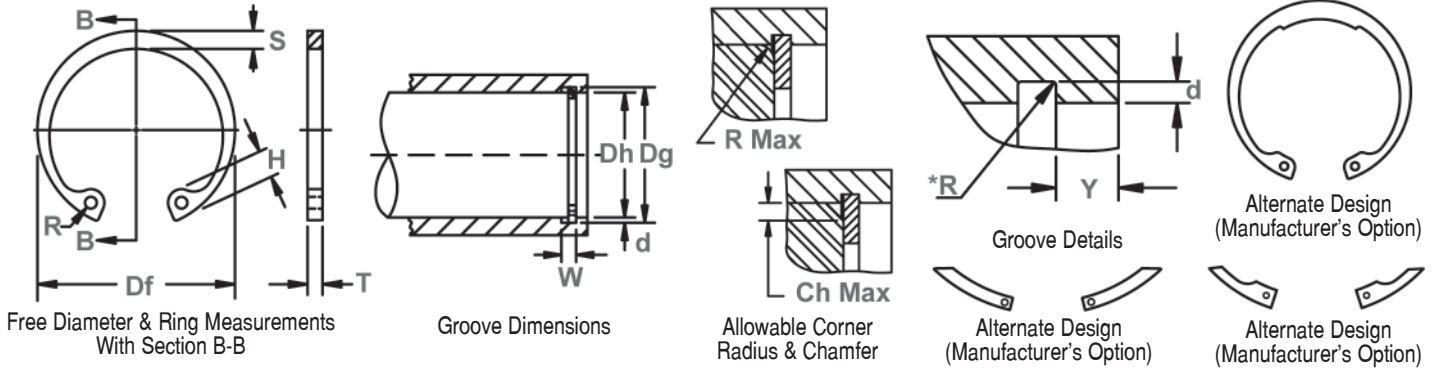

RING NO.	HOUSING Dia. (mm)	GROOVE SIZE						RINGS SIZE & WEIGHT						SUPPLEMENTARY DATA					
		DIAMETER			WIDTH	DEPTH	THICKNESS ***		FREE DIAMETER		LUG HT.	MAX. SEC.	HOLE DIA.	WEIGHT	EDGE MARGIN	THRUST LOAD Ring	THRUST LOAD Groove	Allowable Rad./Cham.	Max. load w/ R/Ch Max.
		Dh	Dg	Tol.	W Min.	d	T	Tol.	Df	Tol.	H Max.	S Ref.	R Min.	kg/1000	Y Min.	Pr kN	Pg kN	R/Ch Max.	P'r kN
DHO-470	470	482,0	+1,00	7,20	6,00	7,00	-0,15	490,0	+2,00	26,2	26,0	6,0	1595,0	18,0	1330	1495	6,0	132,0	
DHO-480	480	492,0		7,20	6,00	7,00		500,0	-1,00	26,2	26,0	6,0	1640,0	18,0	1306	1526	6,0	130,0	
DHO-490	490	502,0		7,20	6,00	7,00		510,0	26,2	26,0	6,0	1685,0	18,0	1280	1558	6,0	127,0		
DHO-500	500	512,0		7,20	6,00	7,00		520,0	26,2	26,0	6,0	1730,0	18,0	1256	1588	6,0	125,0		
DHO-510	510	524,0		8,20	7,00	8,00		535,0	26,2	26,0	6,0	2250,0	21,0	1834	1894	7,0	156,0		
DHO-520	520	534,0		8,20	7,00	8,00		545,0	26,2	26,0	6,0	2290,0	21,0	1802	1931	7,0	153,0		
DHO-530	530	544,0		8,20	7,00	8,00		555,0	26,2	26,0	6,0	2335,0	21,0	1768	1968	7,0	150,0		
DHO-540	540	554,0		8,20	7,00	8,00		565,0	+3,00	26,2	26,0	6,0	2380,0	21,0	1738	2004	7,0	148,0	
DHO-550	550	564,0		8,20	7,00	8,00		575,0	-1,50	26,2	26,0	6,0	2430,0	21,0	1711	2041	7,0	145,0	
DHO-560	560	574,0		8,20	7,00	8,00		585,0	26,2	26,0	6,0	2495,0	21,0	1682	2078	7,0	143,0		
DHO-570	570	584,0		8,20	7,00	8,00		595,0	26,2	26,0	6,0	2560,0	21,0	1650	2114	7,0	141,0		
DHO-580	580	594,0		8,20	7,00	8,00		605,0	26,2	26,0	6,0	2625,0	21,0	1627	2151	7,0	138,0		
DHO-590	590	604,0		8,20	7,00	8,00		615,0	26,2	26,0	6,0	2700,0	21,0	1601	2188	7,0	136,0		
DHO-600	600	614,0		8,20	7,00	8,00		625,0	26,2	26,0	6,0	2770,0	21,0	1571	2221	7,0	134,0		
DHO-650	650	666,0		9,30	8,00	9,00		680,0	-0,20	34,0	34,0	6,0	3600,0	24,0	2654	2753	7,0	226,0	
DHO-700**	700	716,0		9,30	8,00	9,00		730,0		34,0	34,0	6,0	4120,0	24,0	2471	2966	7,0	210,0	
DHO-750**	750	768,0	9,30	9,00	9,00	785,0	34,0	34,0		9,0	4540,0	27,0	2310	3566	7,0	196,0			
DHO-800**	800	818,0	9,30	9,00	9,00	835,0	+4,00	34,0		34,0	9,0	5450,0	27,0	2176	3800	7,0	184,0		
DHO-850**	850	870,0	9,30	10,00	9,00	890,0	-2,00	34,0		34,0	9,0	5990,0	30,0	2045	4500	7,0	173,0		
DHO-900**	900	920,0	9,30	10,00	9,00	940,0	34,0	34,0		9,0	6740,0	30,0	1938	4766	7,0	164,0			
DHO-950**	950	972,0	9,30	11,00	9,00	1000,0	34,0	34,0		9,0	7930,0	33,0	1840	5608	7,0	156,0			
DHO-1000**	1000	1022,0	9,30	11,00	9,00	1050,0	34,0	34,0		9,0	8880,0	33,0	1752	5825	7,0	148,0			

ALL DIMENSIONS IN MILLIMETERS.

\*The radius "R" on the load side must not exceed 0.1 T.

\*\* THESE PARTS ARE MADE WITH A CONSTANT SECTION WIDTH (NO TAPER)

\*\*\* FOR PLATED RINGS, ADD 0.05 TO THE LISTED MAXIMUM THICKNESS.

MAXIMUM RING THICKNESS WILL BE A MINIMUM OF 0.005 LESS THAN THE LISTED GROOVE WIDTH (W) MINIMUM.

HARDNESS RANGES: STAINLESS STEEL RINGS (DIN 1.4122 X39CrMo17)

RING TYPE	SIZE RANGE	HARDNESS			
		HV	HRC	15N	30N
DHO	ALL	470-580	47-54	84-87.5	66-72

HARDNESS RANGES: STAINLESS STEEL RINGS (PH 15-7MO)

RING TYPE	SIZE RANGE	HARDNESS		
		VICKERS	ROCKWELL	
			HRC	LOWER SCALE*
DHO	8-22	435-530	44-51	63-69.5 HR30N
	23-1000	435-530	44-51	-

\*WHERE APPLICABLE





# DHI Housing Rings

## Axially Assembled, Internal Inverted, Metric

Functions like an DHO ring in a housing/bore, only the lugs are "reversed."  
 This version reduces the distance the lugs of the standard DHO extend into the inner circumference of the housing/bore and allows for another assembly to pass through unimpeded.

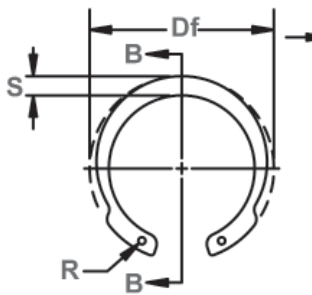

Free Diameter & Ring Measurements With Section B-B

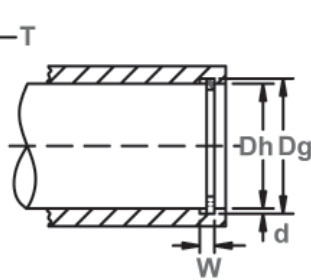

Housing Diameter & Groove Dimensions

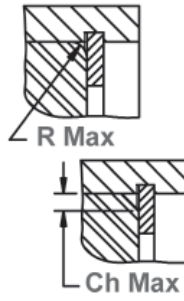

Allowable Corner Radius & Chamfer

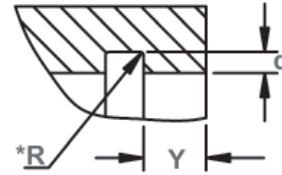

Exploded Groove Profile & Edge Margin (Y) \*The radius "R" on the load side must not exceed 0.1T.

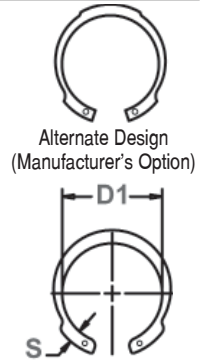

Alternate Design (Manufacturer's Option)

Measuring Free Diameter (Df)  
 DHI Series Df = D1 + 2S

RING NO.	HOUSING DIAMETER		GROOVE SIZE				RING SIZE & WEIGHT						SUPPLEMENTARY DATA					
			DIAMETER		WIDTH	DEPTH	THICKNESS ***		FREE DIAMETER		MAX. SEC.	HOLE DIA.	WEIGHT	EDGE MARGIN	THRUST LOAD Ring	THRUST LOAD Groove	Allowable Rad./Cham.	Max. load w/ R/Ch. Max.
	Dh	Dg	Tol.	W Min.	d	T	Tol.	Df	Tol.	S	Tol.	R Min.	kg/1000	Y Min.	Pr kN	Pg kN	R/Ch. Max.	Pr kN
DHI-12	12	12,6		0,70	0,30	0,60	-0,05	13,1		1,8		1,0	0,25	0,9	1,8	0,75	0,8	1,0
DHI-15	15	15,7	+0,11	0,90	0,35	0,80		16,1		2,0		1,0	0,41	1,0	3,3	1,33	1,0	1,9
DHI-16	16	16,8		1,10	0,40	1,00		17,3		2,1		1,3	0,53	1,2	5,2	1,67	1,0	3,1
DHI-17	17	17,8		1,10	0,40	1,00		18,3	+0,42	2,1		1,3	0,58	1,2	5,8	1,70	1,0	3,0
DHI-18	18	19,0		1,10	0,50	1,00		19,5	-0,13	2,2		1,3	0,62	1,5	6,3	1,78	1,0	3,0
DHI-19	19	20,0		1,10	0,50	1,00		20,5		2,2		1,3	0,66	1,5	6,6	2,50	1,0	2,8
DHI-20	20	21,0	+0,15	1,10	0,50	1,00		21,5		2,3		1,3	0,80	1,5	7,0	2,66	1,0	2,9
DHI-21	21	22,0		1,10	0,50	1,00		22,5		2,4		1,3	0,81	1,5	7,4	2,73	1,0	2,8
DHI-22	22	23,0		1,10	0,50	1,00		23,5		2,4		1,3	0,83	1,5	7,5	2,80	1,0	2,8
DHI-24	24	25,2		1,30	0,60	1,20		25,9		2,8	±0,1	1,5	1,30	1,8	14,5	3,68	1,0	4,8
DHI-25	25	26,2		1,30	0,60	1,20		26,9	+0,42	2,8		1,5	1,40	1,8	14,8	4,00	1,0	5,0
DHI-26	26	27,2	+0,21	1,30	0,60	1,20	-0,06	27,9	-0,21	3,0		1,5	1,50	1,8	15,3	4,17	1,0	5,2
DHI-27	27	28,4		1,30	0,70	1,20		29,1		3,0		1,5	1,53	2,1	15,0	5,00	1,0	5,1
DHI-28	28	29,4		1,30	0,70	1,20		30,1		3,1		1,5	1,80	2,1	15,3	5,10	1,0	5,2
DHI-30	30	31,4		1,30	0,70	1,20		32,1		3,2		1,5	2,03	2,1	14,9	5,50	1,0	5,1
DHI-32	32	33,7		1,30	0,85	1,20		34,4	+0,50	3,3		1,5	2,05	2,5	14,1	7,00	1,0	4,9
DHI-33	33	34,7		1,30	0,85	1,20		35,5	-0,25	3,3		1,5	2,35	2,5	13,8	7,30	1,0	4,8
DHI-34	34	35,7	+0,25	1,60	0,85	1,50		36,5		3,4		1,5	2,95	2,5	24,0	7,50	1,5	6,0
DHI-35	35	37,0		1,60	1,00	1,50		37,8		3,4		1,7	3,20	3,0	26,4	9,20	1,5	6,3
DHI-36	36	38,0		1,60	1,00	1,50		38,8		3,6		1,7	3,23	3,0	27,5	9,70	1,5	6,6
DHI-38	38	40,0		1,60	1,00	1,50		40,8		3,8		1,7	3,68	3,0	28,0	10,20	1,5	6,7

\*\*\* FOR PLATED RINGS, ADD 0.05 TO THE LISTED MAXIMUM THICKNESS. MAXIMUM RING THICKNESS WILL BE A MINIMUM OF 0.005 LESS THAN THE LISTED GROOVE WIDTH (W) MINIMUM.

ALL DIMENSIONS IN MILLIMETERS.

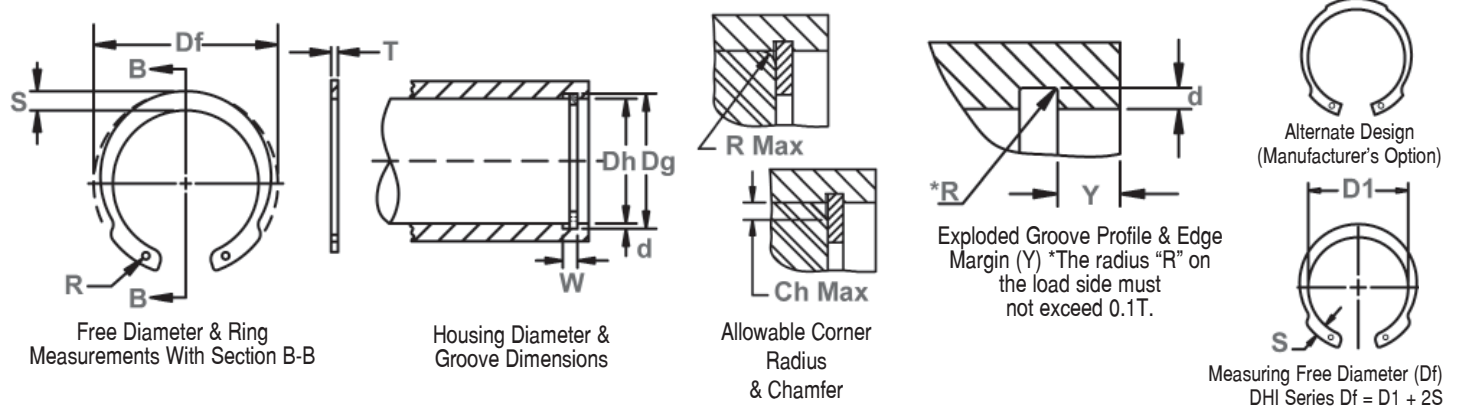

RING NO.	HOUSING DIAMETER		GROOVE SIZE					RING SIZE & WEIGHT					SUPPLEMENTARY DATA						
			DIAMETER		WIDTH	DEPTH	THICKNESS ***		FREE DIAMETER		MAX. SEC.	HOLE DIA.	WEIGHT	EDGE MARGIN	THRUST LOAD Ring	THRUST LOAD Groove	Allowable Rad./Cham.	Max. load w/ R/Ch. Max.	
	Dh	Dg	Tol.	W Min.	d	T	Tol.	Df	Tol.	S	Tol.	R Min.	kg/1000	Y Min.	Pr kN	Pg kN	R/Ch. Max.	P'r kN	
DHI-40	40	42,5	+0,25	1,85	1,25	1,75	-0,06	43,5	+0,90	4,2	±0,2	2,0	4,75	3,8	45,5	13,50	2,0	8,4	
DHI-42	42	44,5		1,85	1,25	1,75		45,5	-0,39	4,2		2,0	5,20	3,8	45,5	14,10	2,0	8,5	
DHI-45	45	47,5		1,85	1,25	1,75		48,5		4,2		2,0	6,00	3,8	44,0	15,00	2,0	8,4	
DHI-47	47	49,5	+0,30	1,85	1,25	1,75	-0,07	50,5	+1,10	4,7	±0,3	2,0	6,50	3,8	45,0	15,80	2,0	8,7	
DHI-48	48	50,5		1,85	1,25	1,75		51,5				4,7	2,0	7,00	3,8	48,0	16,00	2,0	9,1
DHI-50	50	53,0		2,15	1,50	2,00		54,2				5,2	2,5	8,50	4,5	69,0	20,00	2,0	13,4
DHI-52	52	55,0	+0,35	2,15	1,50	2,00	-0,08	56,2	+1,30	5,2	±0,3	2,5	9,00	4,5	66,5	20,80	2,0	13,3	
DHI-55	55	58,0		2,15	1,50	2,00		59,2				5,2	2,5	10,00	4,5	66,0	22,20	2,0	13,3
DHI-57	57	60,0		2,15	1,50	2,00		61,2				5,2	2,5	10,25	4,5	65,0	23,00	2,0	13,1
DHI-58	58	61,0	+0,35	2,15	1,50	2,00	-0,07	62,2	+1,10	5,2	±0,2	2,5	10,50	4,5	64,0	23,30	2,0	12,9	
DHI-60	60	63,0		2,15	1,50	2,00		64,2				5,2	2,5	11,25	4,5	62,0	24,20	2,0	12,7
DHI-62	62	65,0		2,15	1,50	2,00		66,2				5,2	2,5	11,75	4,5	60,0	25,00	2,0	12,3
DHI-65	65	68,0	+0,35	2,65	1,50	2,50	-0,08	69,2	+1,30	5,7	±0,3	2,5	16,25	4,5	122,0	25,80	2,5	20,6	
DHI-67	67	70,0		2,65	1,50	2,50		71,5				5,7	2,5	17,30	4,5	122,0	26,80	2,5	20,8
DHI-68	68	71,0		2,65	1,50	2,50		72,5				5,7	2,5	17,75	4,5	123,0	27,20	2,5	21,0
DHI-72	72	75,0	+0,35	2,65	1,50	2,50	-0,08	76,5	+1,30	6,0	±0,3	2,5	19,60	4,5	119,0	28,80	2,5	20,8	
DHI-80	80	83,5		2,65	1,75	2,50		85,5				6,0	2,5	22,90	5,3	110,0	37,40	2,5	19,6
DHI-85	85	88,5		3,15	1,75	3,00		90,5				6,6	3,0	30,00	5,3	176,0	39,70	3,0	27,2
DHI-90	90	93,5	+0,35	3,15	1,75	3,00	-0,08	95,5	+1,30	6,6	±0,3	3,0	33,00	5,3	169,0	42,00	3,0	26,6	
DHI-95	95	98,5		3,15	1,75	3,00		100,5				7,4	3,0	37,50	5,3	168,0	43,50	3,0	27,0
DHI-100	100	103,5		3,15	1,75	3,00		105,5				7,4	3,0	41,90	5,3	165,0	46,70	3,0	26,8

\*\*\* FOR PLATED RINGS, ADD 0.05 TO THE LISTED MAXIMUM THICKNESS. MAXIMUM RING THICKNESS WILL BE A MINIMUM OF 0.005 LESS THAN THE LISTED GROOVE WIDTH (W) MINIMUM.

ALL DIMENSIONS IN MILLIMETERS.

HARDNESS RANGES: STAINLESS STEEL RINGS (DIN 1.4122 X39CrMo17)

RING TYPE	SIZE RANGE	HARDNESS			
		HV	HRC	15N	30N
DHI	ALL	470-580	47-54	84-87.5	66-72

HARDNESS RANGES: CARBON STEEL RINGS (SAE 1060-1090)

RING TYPE	SIZE RANGE	HARDNESS		
		VICKERS	ROCKWELL	
			HRC	LOWER SCALE*
DHI	12-22	470-580	47-54	66-72 HR30N
	23-48	470-580	47-54	-
	50-100	435-530	44-51	-

\*WHERE APPLICABLE





# DHT Housing Rings

(DIN 984)

## Axially Assembled, Internal Teeth, Metric

Similar in design to the DHO internal ring, this features several "teeth" equally distributed along the circumference of the ring. The increased shoulder offered by the teeth is particularly effective in retaining applications with large radii or chamfers.

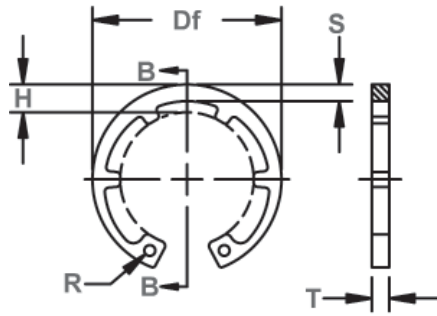

Free Diameter and Ring Measurements With Section B-B

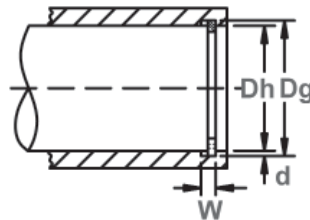

Housing Diameter & Groove Dimensions

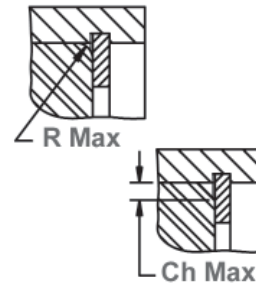

Allowable Corner Radius & Chamfer

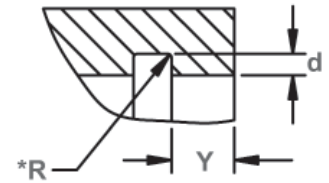

Exploded Groove Profile & Edge Margin (Y)  
\*The radius "R" on the load side must not exceed 0.1T.

RING NO.	HOUSING DIA.		GROOVE SIZE			RING SIZE & WEIGHT									SUPPLEMENTARY DATA				
			DIAMETER		WIDTH	DEPTH	THICKNESS ***		FREE DIAMETER		LUG HT.	MAX. SEC.	HOLE DIA.	WEIGHT	EDGE MARGIN	THRUST LOAD Ring	THRUST LOAD Groove	Allowable Rad/ Cham.	Max. load w/ R/Ch. Max.
	Dh	Dg	Tol.	W Min.	d	T	Tol.	Df	Tol.	H Max.	S Ref.	R Min.	kg/ 1000	Y Min.	Pr kN	Pg kN	R/Ch Max.	Pr kN	
DHT-16	16	16.8	+0,11	1,10	0,40	1,00		17,3		3,4	2,1	1,7	0,72	1,2	5,5	3,4	1,0	2,5	
DHT-17	17	17,8		1,10	0,40	1,00		18,3		3,7	2,2	1,7	0,80	1,2	6,0	3,6	1,0	2,5	
DHT-18	18	19,0		1,10	0,50	1,00		19,5		3,8	2,2	1,7	0,90	1,5	6,5	4,8	1,0	2,6	
DHT-19	19	20,0		1,10	0,50	1,00		20,5	+0,42	3,8	2,3	2,0	0,99	1,5	6,8	5,1	1,0	2,6	
DHT-20	20	21,0	+0,15	1,10	0,50	1,00		21,5	-0,13	3,9	2,4	2,0	1,06	1,5	7,2	5,4	1,0	2,6	
DHT-21	21	22,0		1,10	0,50	1,00		22,5		4,0	2,4	2,0	1,17	1,5	7,6	5,7	1,0	2,6	
DHT-22	22	23,0		1,10	0,50	1,00		23,5		4,0	2,6	2,0	1,28	1,5	8,0	5,9	1,0	2,7	
DHT-23	23	24,1		1,30	0,55	1,20		24,6		4,1	2,6	2,0	1,48	1,6	13,8	6,8	1,0	4,5	
DHT-24	24	25,2		1,30	0,60	1,20		25,9		4,2	2,6	2,0	1,60	1,8	13,9	7,7	1,0	4,6	
DHT-25	25	26,2		1,30	0,60	1,20		26,9	+0,42	4,4	2,8	2,0	1,72	1,8	14,6	8,0	1,0	4,7	
DHT-26	26	27,2	+0,21	1,30	0,60	1,20		28,5	-0,21	4,4	2,8	2,0	2,00	1,8	13,8	8,4	1,0	4,6	
DHT-27	27	28,4		1,30	0,70	1,20		29,1		4,5	2,9	2,0	2,00	2,1	13,3	10,1	1,0	4,5	
DHT-28	28	29,4		1,30	0,70	1,20	-0,06	30,1		4,9	3,0	2,0	2,10	2,1	13,3	10,5	1,0	4,5	
DHT-30	30	31,4		1,30	0,70	1,20		32,1		4,9	3,2	2,0	2,35	2,1	13,7	11,3	1,0	4,6	
DHT-31	31	32,7		1,30	0,85	1,20		33,4		5,0	3,2	2,5	2,42	2,5	13,8	14,1	1,0	4,7	
DHT-32	32	33,7		1,30	0,85	1,20		34,4	+0,50	5,1	3,3	2,5	2,50	2,5	13,8	14,6	1,0	4,7	
DHT-33	33	34,7		1,30	0,85	1,20		35,5	-0,25	5,1	3,3	2,5	2,65	2,5	14,3	15,0	1,5	4,9	
DHT-34	34	35,7		1,60	0,85	1,50		36,5		5,3	3,4	2,5	3,80	2,5	26,2	15,4	1,5	6,3	
DHT-35	35	37,0		1,60	1,00	1,50		37,8		5,5	3,6	2,5	4,00	3,0	26,9	18,8	1,5	6,4	
DHT-36	36	38,0	+0,25	1,60	1,00	1,50		38,8		5,6	3,6	2,5	4,15	3,0	26,4	19,4	1,5	6,4	
DHT-38	38	40,0		1,60	1,00	1,50		40,8		6,1	3,8	2,5	4,40	3,0	28,2	22,5	1,5	6,7	
DHT-40	40	42,5		1,85	1,25	1,75		43,5		7,2	4,0	2,5	5,30	3,8	44,6	27,0	2,0	8,3	
DHT-42	42	44,5		1,85	1,25	1,75		45,5	+0,90	7,2	4,1	2,5	6,00	3,8	44,7	28,4	2,0	8,4	
DHT-44	44	46,5		1,85	1,25	1,75		47,5	-0,39	7,2	4,2	2,5	6,45	3,8	43,3	29,5	2,0	8,3	
DHT-45	45	47,5		1,85	1,25	1,75		48,5		7,2	4,3	2,5	6,60	3,8	43,1	30,2	2,0	8,2	
DHT-47	47	49,5		1,85	1,25	1,75		50,5	+1,10	7,2	4,5	2,5	6,90	3,8	43,5	31,4	2,0	8,3	
DHT-48	48	50,5	+0,30	1,85	1,25	1,75		51,5	-0,46	7,2	4,5	2,5	7,50	3,8	43,2	32,0	2,0	8,4	

\*\*\* FOR PLATED RINGS, ADD 0.05 TO THE LISTED MAXIMUM THICKNESS. MAXIMUM RING THICKNESS WILL BE A MINIMUM OF 0.005 LESS THAN THE LISTED GROOVE WIDTH (W) MINIMUM.  
ALL DIMENSIONS IN MILLIMETERS.



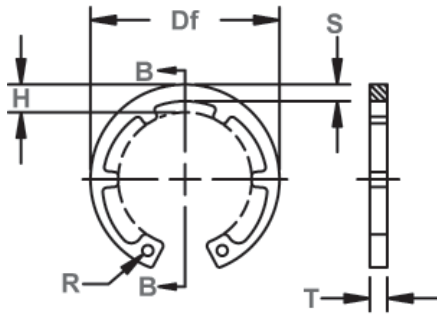

Free Diameter and Ring Measurements With Section B-B

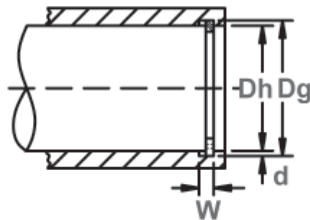

Housing Diameter & Groove Dimensions

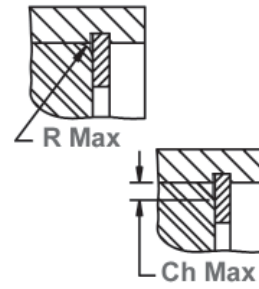

Allowable Corner Radius & Chamfer

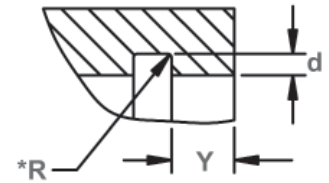

Exploded Groove Profile & Edge Margin (Y)  
\*The radius "R" on the load side must not exceed 0.1T.

RING NO.	HOUSING DIA.		GROOVE SIZE			RING SIZE & WEIGHT								SUPPLEMENTARY DATA				
			DIAMETER		WIDTH	DEPTH	THICKNESS ***		FREE DIAMETER		LUG HT.	MAX. SEC.	HOLE DIA.	WEIGHT	EDGE MARGIN	THRUST LOAD Ring	THRUST LOAD Groove	Allowable Rad/ Cham.
	Dh	Dg	Tol.	W Min.	d	T	Tol.	Df	Tol.	H Max.	S Ref.	R Min.	kg/ 1000	Y Min.	Pr kN	Pg kN	R/Ch Max.	P'r kN
DHT-50	50	53.0		2,15	1,50	2,00		54,2		8,2	4,7	2,5	8,50	4,5	60,8	40,5	2,0	12,1
DHT-52	52	55,0		2,15	1,50	2,00		56,2		8,2	4,7	2,5	9,40	4,5	60,2	42,0	2,0	12,0
DHT-55	55	58,0		2,15	1,50	2,00		59,2		8,2	5,1	2,5	9,75	4,5	60,3	44,4	2,0	12,5
DHT-57	57	60,0		2,15	1,50	2,00		61,2		8,2	5,2	2,5	11,65	4,5	60,8	46,0	2,0	12,7
DHT-58	58	61,0		2,15	1,50	2,00		62,2	+1,10	8,2	5,3	2,5	12,00	4,5	60,8	46,7	2,0	12,7
DHT-60	60	63,0	+0,30	2,15	1,50	2,00	-0,07	64,2	-0,46	8,2	5,5	2,5	12,70	4,5	61,0	48,3	2,0	13,0
DHT-62	62	65,0		2,15	1,50	2,00		66,2		8,2	5,6	2,5	12,75	4,5	60,9	49,8	2,0	13,0
DHT-65	65	68,0		2,65	1,50	2,50		69,2		10,2	5,8	3,0	16,70	4,5	121,0	51,8	2,5	20,8
DHT-67	67	70,0		2,65	1,50	2,50		71,5		10,2	6,0	3,0	18,60	4,5	121,0	53,8	2,5	21,1
DHT-68	68	71,0		2,65	1,50	2,50		72,5		10,2	6,1	3,0	19,30	4,5	121,0	54,5	2,5	21,2
DHT-70	70	73,0		2,65	1,50	2,50		74,5		10,2	6,2	3,0	20,20	4,5	119,0	56,2	2,5	21,0
DHT-72	72	75,0		2,65	1,50	2,50		76,5		10,2	6,4	3,0	21,20	4,5	119,0	58,0	2,5	21,0
DHT-75	75	78,0		2,65	1,50	2,50		79,5		10,2	6,6	3,0	22,60	4,5	118,0	60,0	2,5	21,0
DHT-80	80	83,5		2,65	1,75	2,50		85,5		10,2	7,0	3,0	25,00	5,3	120,0	74,6	2,5	21,8
DHT-85	85	88,5		3,15	1,75	3,00		90,5		12,2	7,4	3,5	30,10	5,3	201,0	79,5	3,0	31,2
DHT-90	90	93,5	+0,35	3,15	1,75	3,00	-0,08	95,5	+1,30	12,2	7,7	3,5	35,50	5,3	199,0	84,0	3,0	31,4
DHT-95	95	98,5		3,15	1,75	3,00		100,5	-0,54	12,2	8,1	3,5	40,00	5,3	195,0	88,6	3,0	31,4
DHT-100	100	103,5		3,15	1,75	3,00		105,5		12,2	8,5	3,5	43,50	5,3	188,0	93,1	3,0	30,8
DHT-110	110	114,0	+0,54	4,15	2,00	4,00		117,0		12,2	9,0	3,5	73,00	6,0	415,0	117,0	3,0	71,0
DHT-115	115	119,0		4,15	2,00	4,00		122,0		12,2	9,3	3,5	82,00	6,0	409,0	122,0	3,0	71,2
DHT-120	120	124,0		4,15	2,00	4,00		127,0		12,2	9,6	3,5	87,00	6,0	396,0	127,0	3,0	70,0
DHT-125	125	129,0		4,15	2,00	4,00		132,0		12,2	9,9	4,0	92,00	6,0	385,0	132,0	3,0	70,0
DHT-130	130	134,0		4,15	2,00	4,00		137,0	-1,10	12,2	10,2	4,0	102,00	6,0	374,0	138,0	3,0	69,0
DHT-140	140	144,0	+0,63	4,15	2,00	4,00		148,0	+1,50	14,2	10,7	4,0	112,00	6,0	350,0	148,0	3,0	66,5
DHT-150	150	155,0		4,15	2,50	4,00		158,0	-0,63	14,2	11,1	4,0	123,00	7,5	326,0	191,0	3,0	64,0
DHT-160	160	165,0		4,15	2,50	4,00		169,0		14,2	11,8	4,5	133,00	7,5	321,0	212,0	3,5	54,5
DHT-170	170	175,0		4,15	2,50	4,00		179,0		14,2	12,3	4,5	145,00	7,5	349,0	225,0	3,5	59,0

\*\*\* FOR PLATED RINGS, ADD 0.05 TO THE LISTED MAXIMUM THICKNESS. MAXIMUM RING THICKNESS WILL BE A MINIMUM OF 0.005 LESS THAN THE LISTED GROOVE WIDTH (W) MINIMUM.  
ALL DIMENSIONS IN MILLIMETERS.

NUMBER OF TEETH (INCLUDING LUGS)

RING TYPE	SIZE RANGE	#TEETH
DHT	16-58	6
	60-170	8

HARDNESS RANGES: CARBON STEEL RINGS (SAE 1060-1090)

RING TYPE	SIZE RANGE	HARDNESS		
		VICKERS	ROCKWELL	
			HRC	LOWER SCALE*
DHT	16-22	470-580	47-54	66-72 HR30N
	23-48	470-580	47-54	-
	50-170	435-530	44-51	-

\*WHERE APPLICABLE

HARDNESS RANGES: STAINLESS STEEL RINGS (DIN 1.4122 X39CrMo17)

RING TYPE	SIZE RANGE	HARDNESS			
		HV	HRC	15N	30N
DHT	ALL	470-580	47-54	84-87.5	66-72





# DHR Housing Rings

## DIN 472 - Heavy Type

### Axially Assembled, Internal Reinforced, Metric

A thicker version of the DHO featuring a larger radial width than this ring. Once installed in the groove of a housing/bore, the portion of the ring protruding from the groove (also called a "shoulder") holds an assembly in place.

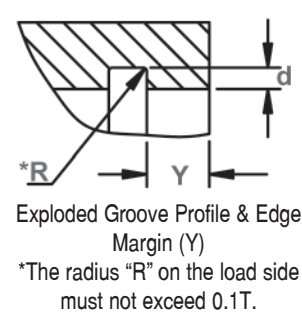
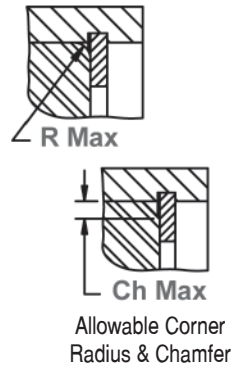
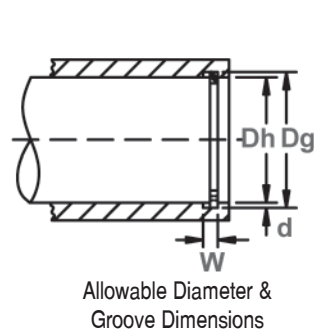
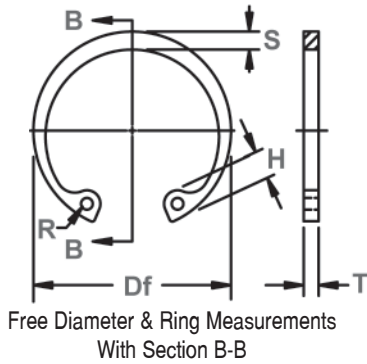

RING NO.	HOUSING DIA.	GROOVE SIZE					RING SIZE & WEIGHT							SUPPLEMENTARY DATA				
		DIAMETER		WIDTH	DEPTH	THICKNESS ***	FREE DIAMETER		LUG HT.	MAX. SEC.	HOLE DIA.	WEIGHT	EDGE MARGIN	THRUST LOAD Ring	THRUST LOAD Groove	Allowable Rad/Cham.	Max. load w/ R/Ch. Max.	
		Dh	Dg	Tol.	W Min.	d	T	Tol.	Df	Tol.	H Max.	S Ref.	R Min.	kg/1000	Y Min.	Pr kN	Pg kN	R/Ch Max.
DHR-20	20	21.0	+0,15	1,60	0,50	1,50		21,5		4,5	2,4	2,0	1,4	1,5	16,2	5,4	1,0	5,8
DHR-22	22	23,0		1,60	0,50	1,50		23,5	+0,42	4,7	2,8	2,0	1,9	1,5	18,0	5,9	1,0	6,1
DHR-24	24	25,2		1,60	0,60	1,50		25,9	-0,21	4,9	3,0	2,0	2,0	1,8	21,7	7,7	1,0	7,2
DHR-25	25	26,2		1,60	0,60	1,50		26,9		5,0	3,1	2,0	2,1	1,8	22,8	8,0	1,0	7,3
DHR-26	26	27,2	+0,21	1,60	0,60	1,50		27,9		5,1	3,1	2,0	2,3	1,8	21,6	8,4	1,0	7,2
DHR-27	27	28,4		1,60	0,70	1,50		29,1		5,1	3,2	2,0	2,4	2,1	20,8	10,1	1,0	7,0
DHR-28	28	29,4		1,60	0,70	1,50	-0,06	30,1		5,3	3,2	2,0	2,5	2,1	20,8	10,5	1,0	7,0
DHR-30	30	31,4		1,60	0,70	1,50		32,1		5,5	3,3	2,0	2,7	2,1	21,4	11,3	1,0	7,2
DHR-32	32	33,7		1,60	0,85	1,50		34,4	+0,50	5,7	3,4	2,0	2,9	2,6	21,4	14,6	1,0	7,3
DHR-34	34	35,7		1,85	0,85	1,75		36,5	-0,25	5,9	3,7	2,5	4,1	2,6	35,6	15,4	1,5	8,6
DHR-35	35	37,0		1,85	1,00	1,75		37,8		6,0	3,8	2,5	4,5	3,0	36,6	18,8	1,5	8,7
DHR-37	37	39,0	+0,25	1,85	1,00	1,75		39,8		6,2	3,9	2,5	4,7	3,0	36,6	19,8	1,5	8,8
DHR-38	38	40,0		1,85	1,00	1,75		40,8		6,3	3,9	2,5	4,8	3,0	38,3	22,5	1,5	9,1
DHR-40	40	42,5		2,15	1,25	2,00		43,5	+0,90	6,5	3,9	2,5	5,1	3,8	58,4	27,0	2,0	10,9
DHR-42	42	44,5		2,15	1,25	2,00		45,5	-0,39	6,7	4,1	2,5	5,6	3,8	58,5	28,4	2,0	11,0
DHR-45	45	47,5		2,15	1,25	2,00		48,5		7,0	4,3	2,5	6,3	3,8	56,5	30,2	2,0	10,7
DHR-47	47	49,5		2,15	1,25	2,00	-0,07	50,5		7,2	4,4	2,5	6,7	3,8	57,0	31,4	2,0	10,8
DHR-50	50	53,0		2,65	1,50	2,50		54,2		7,5	4,6	2,5	8,8	4,5	95,5	40,5	2,0	19,0
DHR-52	52	55,0		2,65	1,50	2,50		56,2		7,7	4,7	2,5	9,9	4,5	94,6	42,0	2,0	18,8
DHR-55	55	58,0		2,65	1,50	2,50		59,2		8,0	5,0	2,5	10,4	4,5	94,7	44,4	2,0	19,6
DHR-60	60	63,0		3,15	1,50	3,00		64,2	+1,10	8,5	5,4	2,5	15,9	4,5	137,0	48,3	2,0	29,2
DHR-62	62	65,0		3,15	1,50	3,00		66,2	-0,46	8,6	5,5	2,5	16,1	4,5	137,0	49,8	2,0	29,2
DHR-64	64	67,0	+0,30	3,15	1,50	3,00		68,2		8,7	5,6	3,0	16,5	4,5	137,0	51,4	2,0	30,0
DHR-65	65	68,0		3,15	1,50	3,00	-0,08	69,2		8,7	5,8	3,0	16,6	4,5	174,0	51,8	2,5	30,0
DHR-68	68	71,0		3,15	1,50	3,00		72,5		8,8	6,1	3,0	17,2	4,5	174,0	54,5	2,5	30,6
DHR-70	70	73,0		3,15	1,50	3,00		74,5		9,0	6,2	3,0	18,0	4,5	171,0	56,2	2,5	30,3
DHR-72	72	75,0		3,15	1,50	3,00		76,5		9,2	6,4	3,0	21,7	4,5	172,0	58,0	2,5	30,3
DHR-75	75	78,0		3,15	1,50	3,00		79,5		9,3	6,6	3,0	22,6	4,5	170,0	60,0	2,5	30,3
DHR-80	80	83,5		4,15	1,75	4,00		85,5	+1,30	9,5	7,0	3,0	33,2	5,3	308,0	74,6	2,5	56,0
DHR-85	85	88,5		4,15	1,75	4,00		90,5	-0,54	9,7	7,2	3,5	33,8	5,3	358,0	79,5	3,0	55,0
DHR-90	90	93,5	+0,35	4,15	1,75	4,00		95,5		10,0	7,6	3,5	41,3	5,3	354,0	84,0	3,0	56,0
DHR-95	95	98,5		4,15	1,75	4,00	-0,10	100,5		10,3	8,1	3,5	46,7	5,3	347,0	88,6	3,0	56,0
DHR-100	100	103,5		4,15	1,75	4,00		105,5		10,5	8,4	3,5	50,7	5,3	335,0	93,1	3,0	55,0

\*\*\* FOR PLATED RINGS, ADD 0.05 TO THE LISTED MAXIMUM THICKNESS. MAXIMUM RING THICKNESS WILL BE A MINIMUM OF 0.005 LESS THAN THE LISTED GROOVE WIDTH (W) MINIMUM.

ALL DIMENSIONS IN MILLIMETERS.

HARDNESS RANGES: CARBON STEEL RINGS (SAE 1060-1090)

RING TYPE	SIZE RANGE	HV	HRC
DHR	20-48	470-580	47-54
	50-100	435-530	44-51

HARDNESS RANGES: STAINLESS STEEL RINGS (DIN 1.4122 X39CrMo17)

RING TYPE	SIZE RANGE	HARDNESS			
		HV	HRC	15N	30N
DHR	ALL	470-580	47-54	84-87.5	66-72



# Axially Assembled, External Reinforced, Metric

The DSR is an extra thick version of a regular DSH retaining ring.

As such, it is stronger and can withstand greater thrust loads than its standard counterpart.

# DSR Shaft Rings

## DIN 471 - Heavy Type

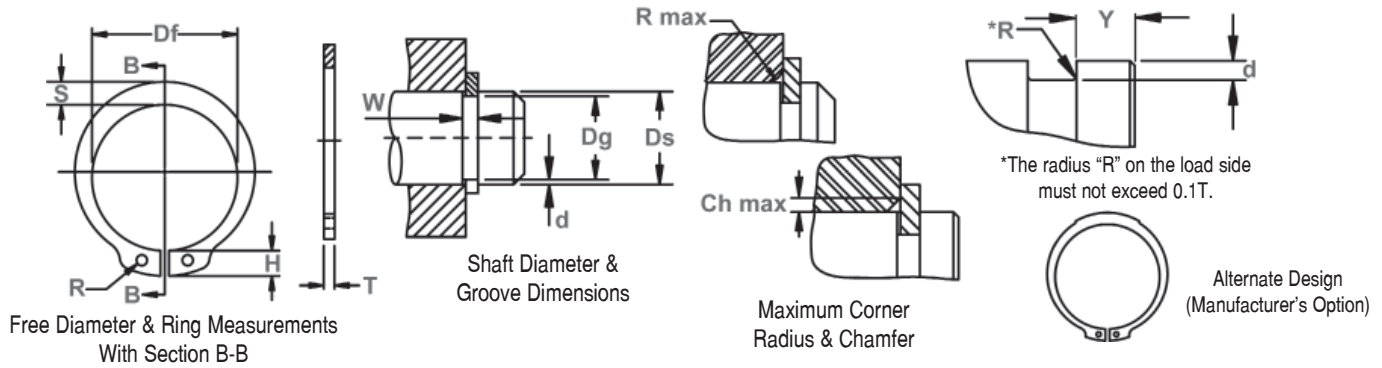

RING NO.	SHAFT DIA.		GROOVE SIZE			RING SIZE & WEIGHT								SUPPLEMENTARY DATA					
			DIAMETER		WIDTH	DEPTH	THICKNESS ***		FREE DIAMETER		LUG HT.	MAX. SEC.	HOLE DIA.	WEIGHT	EDGE MARGIN	THRUST LOAD Ring	THRUST LOAD Groove	Allowable Rad/Cham.	Max. load w/ R/Ch. Max.
	Ds	Dg	Tol.	W Min.	d	T	Tol.	Df	Tol.	H Max.	S Ref.	R Min.	kg/1000	Y Min.	Pr kN	Pg kN	R/Ch Max.	Pr kN	
DSR-12	12	11.5		1.60	0.25	1.50		11.0		3.4	1.8	1.7	0.75	0.7	11.30	1.53	1.0	4.5	75000
DSR-15	15	14.3		1.60	0.35	1.50		13.8	+0,10	4.8	2.4	2.0	1,20	0.7	15.50	3.20	1.0	4.5	50000
DSR-16	16	15.2	-0,11	1.60	0.40	1.50		14.7	-0,36	5.0	2.5	2.0	1,20	1.2	16.70	3.26	1.0	4.5	48000
DSR-17	17	16.2		1.60	0.40	1.50		15.7		5.0	2.6	2.0	1,24	1.2	18.00	4.32	1.0	4.5	46000
DSR-18	18	17.0		1.60	0.50	1.50		16.5		5.1	2.7	2.0	1,54	1.5	26.60	5.50	1.5	5.8	43000
DSR-19	19	18.0		1.60	0.50	1.50	-0,06	17.5		5.1	2.7	2.0	1,45	1.5	26.60	5.78	1.5	5.9	28000
DSR-20	20	19.0	-0,13	1.85	0.50	1.75		18.5		5.5	3.0	2.0	2,25	1.5	36.30	5.60	1.5	8.2	32000
DSR-22	22	21.0		1.85	0.50	1.75		20.5		6.0	3.1	2.0	2,30	1.5	36.00	5.60	1.5	8.1	29000
DSR-24	24	22.9		1.85	0.55	1.75		22.2		6.3	3.2	2.0	2,70	1.7	34.20	7.95	1.5	7.6	29000
DSR-25	25	23.9		2.15	0.55	2.00		23.2	+0,21	6.4	3.4	2.0	3,35	1.7	45.00	8.30	1.5	10.3	25000
DSR-26	26	24.4		2.15	0.80	2.00		23.6	-0,42	6.6	3.3	2.0	3,65	2.4	44.00	10.70	1.5	10.0	27000
DSR-27	27	25.5	-0,21	2.15	0.75	2.00		24.7		6.6	3.4	2.0	3,85	2.3	45.50	10.30	1.5	10.6	25000
DSR-28	28	26.6		2.15	0.70	2.00		25.9		6.5	3.5	2.0	3,90	2.1	57.00	10.00	1.5	13.4	22000
DSR-29	29	27.6		2.15	0.70	2.00		26.9		6.5	3.8	2.0	4,30	2.1	56.50	10.40	1.5	13.3	22000
DSR-30	30	28.6		2.15	0.70	2.00		27.9		6.5	4.1	2.0	5,00	2.1	57.00	10.70	1.5	13.6	21000
DSR-32	32	30.3		2.15	0.85	2.00		29.6		6.5	4.1	2.5	5,40	2.5	57.00	12.90	1.5	13.6	20000
DSR-34	34	32.3		2.65	0.85	2.50	-0,07	31.5	+0,25	6.6	4.2	2.5	6,80	2.5	87.00	16.40	1.5	15.6	18000
DSR-35	35	33.0		2.65	1.00	2.50		32.2	-0,50	6.7	4.2	2.5	7,10	3.0	86.00	17.80	1.5	15.4	17000
DSR-36	36	34.0		2.65	1.00	2.50		33.2		6.7	4.2	2.5	7,50	3.0	101.50	20.10	2.0	18.3	16000
DSR-38	38	36.0		2.65	1.00	2.50		35.2		6.8	4.3	2.5	8,00	3.0	101.00	21.20	2.0	18.6	15000
DSR-40	40	37.5		2.65	1.25	2.50		36.5		7.0	4.4	2.5	8,20	3.8	104.00	25.30	2.0	19.3	14000
DSR-42	42	39.5	-0,25	2.65	1.25	2.50		38.5		7.2	4.5	2.5	9,60	3.8	102.00	26.70	2.0	19.2	13000
DSR-44	44	41.5		2.65	1.25	2.50		40.5	+0,39	7.2	4.5	2.5	10,40	3.8	101.00	27.90	2.0	19.1	12000
DSR-45	45	42.5		2.65	1.25	2.50		41.5	-0,90	7.5	4.7	2.5	10,80	3.8	100.00	28.60	2.0	19.1	11000
DSR-48	48	45.5		2.65	1.25	2.50		44.5		7.8	5.0	2.5	12,20	3.8	101.00	30.70	2.0	19.5	10000
DSR-50	50	47.0		3.15	1.50	3.00		45.8		8.0	5.1	2.5	14,80	4.5	165.00	38.20	2.0	32.4	11000
DSR-52	52	49.0		3.15	1.50	3.00		47.8		8.2	5.2	2.5	15,40	4.5	165.00	39.70	2.5	26.0	10000
DSR-55	55	52.0		3.15	1.50	3.00	-0,08	50.8		8.5	5.4	2.5	17,00	4.5	161.00	42.00	2.5	25.6	9000
DSR-58	58	55.0		3.15	1.50	3.00		53.8		8.8	5.6	2.5	19,40	4.5	160.00	44.30	2.5	26.0	8000
DSR-60	60	57.0		3.15	1.50	3.00		55.8		9.0	5.8	2.5	20,00	4.5	156.00	46.00	2.5	25.4	8000
DSR-65	65	62.0	-0,30	4.15	1.50	4.00		60.8	+0,46	9.3	6.3	3.0	31,00	4.5	346.00	49.80	2.5	58.0	7000
DSR-70	70	67.0		4.15	1.50	4.00		65.5	-1,10	9.5	6.6	3.0	32,20	4.5	343.00	53.80	2.5	59.0	7000
DSR-75	75	72.0		4.15	1.50	4.00		70.5		9.7	7.0	3.0	39,80	4.5	333.00	57.60	2.5	58.0	6000
DSR-80	80	76.5		4.15	1.75	4.00	-0,10	74.5		9.8	7.4	3.0	42,40	5.3	328.00	71.60	3.0	50.0	6000
DSR-85	85	81.5		4.15	1.75	4.00		79.5		10.0	7.8	3.5	47.00	5.3	383.00	76.30	3.0	59.4	6000
DSR-90	90	86.5	-0,35	4.15	1.75	4.00		84.5	+0,54	10.2	10.2	3.5	55.60	5.3	386.00	80.80	3.0	61.0	5000
DSR-95	95	91.5		4.15	1.75	4.00		89.5	-1,30	10.2	8.6	3.5	61.20	5.3	378.00	85.50	3.5	52.0	5000
DSR-100	100	96.5		4.15	1.75	4.00		94.5		10.5	9.0	3.5	72.00	5.3	368.00	90.00	3.5	51.6	4000

\*\*\* FOR PLATED RINGS, ADD 0.05 TO THE LISTED MAXIMUM THICKNESS. MAXIMUM RING THICKNESS WILL BE A MINIMUM OF 0.005 LESS THAN THE LISTED GROOVE WIDTH (W) MINIMUM. ALL DIMENSIONS IN MILLIMETERS.

HARDNESS RANGES: CARBON STEEL RINGS (SAE 1060-1090)

RING TYPE	SIZE RANGE	HV	HRC
DSR	12-48	470-580	47-54
	50-100	435-530	44-51

HARDNESS RANGES: STAINLESS STEEL RINGS (DIN 1.4122 X39CrMo17)

RING TYPE	SIZE RANGE	HARDNESS			
		HV	HRC	15N	30N
DSR	ALL	470-580	47-54	84-87.5	66-72





# DSH Shaft Rings

(DIN 471)

## Axially Assembled, External, Metric

Once installed in the groove of a shaft, the portion of the ring protruding from the groove (also called a "shoulder") holds an assembly in place.

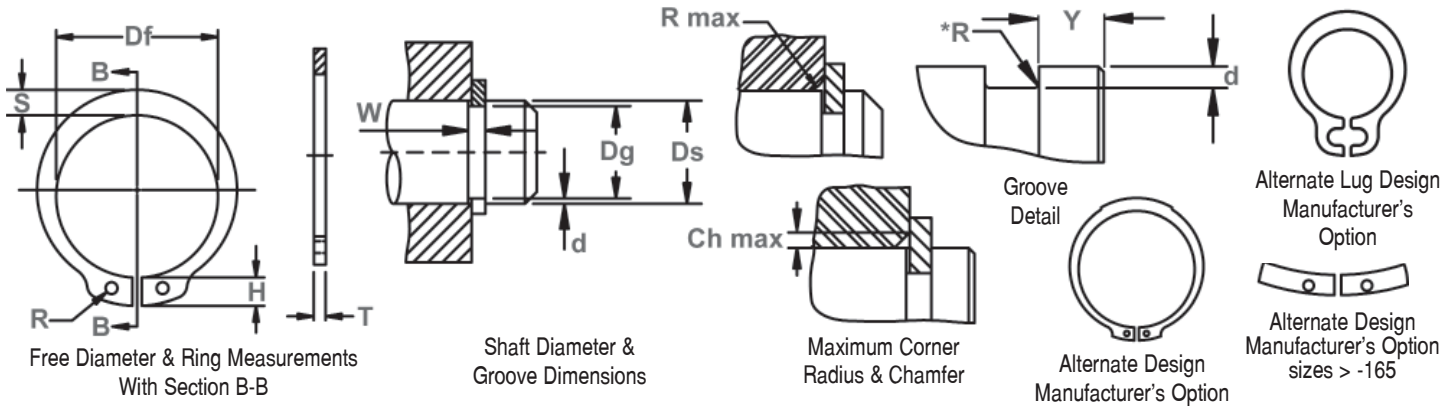

RING NO.	SHAFT DIA. (mm)	GROOVE SIZE					RING SIZE & WEIGHT							SUPPLEMENTARY DATA					
		DIAMETER		WIDTH	DEPTH	THICKNESS ***	FREE DIAMETER		LUG HT.	MAX. SEC.	HOLE DIA.	WEIGHT	EDGE MARGIN	THRUST LOAD Ring	THRUST LOAD Groove	Allowable Rad/Cham.	Max. Load w/Ch Max.	RPM Limits	
		Ds	Dg	TOL.	W Min.	d	T	Tol.	Df	Tol.	H Max.	S Ref.	R Min.	kg/1000	Y Min.	Pr kN	Pg kN	R/Ch Max.	P'r kN
DSH-3	3	2,8		0,50	0,10	0,40		2,7		1,9	0,8	1,0	0,017	0,3	0,47	0,1	0,5	0,27	360000
DSH-4	4	3,8	-0,04	0,50	0,10	0,40		3,7	+0,04	2,2	0,9	1,0	0,022	0,3	0,50	0,2	0,5	0,30	211000
DSH-5	5	4,8		0,70	0,10	0,60	-0,05	4,7	-0,15	2,5	1,1	1,0	0,066	0,3	1,00	0,2	0,5	0,80	154000
DSH-6	6	5,7		0,80	0,15	0,70		5,6		2,7	1,3	1,2	0,084	0,5	1,45	0,4	0,5	0,90	114000
DSH-7	7	6,7		0,90	0,15	0,80		6,5	+0,06	3,1	1,4	1,2	0,121	0,5	2,60	0,5	0,5	1,40	121000
DSH-8	8	7,6	-0,06	0,90	0,20	0,80		7,4	-0,18	3,2	1,5	1,2	0,158	0,6	3,00	0,8	0,5	2,00	96000
DSH-9	9	8,6		1,10	0,20	1,00		8,4		3,3	1,7	1,2	0,300	0,6	3,50	0,9	0,5	2,40	85000
DSH-10	10	9,6		1,10	0,20	1,00		9,3		3,3	1,8	1,5	0,340	0,6	4,00	1,0	1,0	2,40	84000
DSH-11	11	10,5		1,10	0,25	1,00		10,2		3,3	1,8	1,5	0,410	0,8	4,50	1,4	1,0	2,40	70000
DSH-12	12	11,5		1,10	0,25	1,00		11,0		3,3	1,8	1,7	0,500	0,8	5,00	1,5	1,0	2,40	75000
DSH-13	13	12,4		1,10	0,30	1,00		11,9	+0,10	3,4	2,0	1,7	0,530	0,9	5,80	2,0	1,0	2,40	66000
DSH-14	14	13,4	-0,11	1,10	0,30	1,00		12,9	-0,36	3,5	2,1	1,7	0,640	0,9	6,40	2,1	1,0	2,40	58000
DSH-15	15	14,3		1,10	0,35	1,00		13,8		3,6	2,2	1,7	0,670	1,1	6,90	2,6	1,0	2,40	50000
DSH-16	16	15,2		1,10	0,40	1,00		14,7		3,7	2,2	1,7	0,700	1,2	7,40	3,2	1,0	2,40	45000
DSH-17	17	16,2		1,10	0,40	1,00		15,7		3,8	2,3	1,7	0,820	1,2	8,00	3,4	1,0	2,40	41000
DSH-18	18	17,0		1,30	0,50	1,20		16,5		3,9	2,4	2,0	1,110	1,5	17,00	4,5	1,5	3,75	39000
DSH-19	19	18,0		1,30	0,50	1,20		17,5		3,9	2,5	2,0	1,220	1,5	17,00	4,8	1,5	3,80	35000
DSH-20	20	19,0		1,30	0,50	1,20	-0,06	18,5	+0,13	4,0	2,6	2,0	1,300	1,5	17,10	5,0	1,5	3,85	32000
DSH-21	21	20,0	-0,13	1,30	0,50	1,20		19,5	-0,42	4,1	2,7	2,0	1,420	1,5	16,80	5,3	1,5	3,75	29000
DSH-22	22	21,0		1,30	0,50	1,20		20,5		4,2	2,8	2,0	1,500	1,5	16,90	5,6	1,5	3,80	27000
DSH-23	23	22,0	-0,15	1,30	0,50	1,20		21,5		4,3	2,9	2,0	1,630	1,5	16,60	5,9	1,5	3,80	25000
DSH-24	24	22,9		1,30	0,55	1,20		22,2		4,4	3,0	2,0	1,770	1,7	16,10	6,7	1,5	3,65	27000
DSH-25	25	23,9		1,30	0,55	1,20		23,2		4,4	3,0	2,0	1,900	1,7	16,20	7,0	1,5	3,70	25000
DSH-26	26	24,9		1,30	0,55	1,20		24,2		4,5	3,1	2,0	1,960	1,7	16,10	7,3	1,5	3,70	24000
DSH-27	27	25,6	-0,21	1,30	0,70	1,20		24,9	+0,21	4,6	3,1	2,0	2,080	2,1	16,40	9,6	1,5	3,80	22500
DSH-28	28	26,6		1,60	0,70	1,50		25,9	-0,42	4,7	3,2	2,0	2,920	2,1	32,10	10,0	1,5	7,50	21200
DSH-29	29	27,6		1,60	0,70	1,50		26,9		4,8	3,4	2,0	3,200	2,1	31,80	10,3	1,5	7,45	20000
DSH-30	30	28,6		1,60	0,70	1,50		27,9		5,0	3,5	2,0	3,320	2,1	32,10	10,7	1,5	7,65	18900
DSH-31	31	29,3		1,60	0,85	1,50		28,6		5,1	3,5	2,5	3,450	2,6	31,50	13,4	2,0	5,60	17900
DSH-32	32	30,3		1,60	0,85	1,50		29,6		5,2	3,6	2,5	3,540	2,6	31,20	13,8	2,0	5,55	16900
DSH-33	33	31,3	-0,25	1,60	0,85	1,50		30,5	+0,25	5,2	3,7	2,5	3,690	2,6	31,60	14,3	2,0	5,65	17400
DSH-34	34	32,3		1,60	0,85	1,50		31,5	-0,50	5,4	3,8	2,5	3,800	2,6	31,30	14,7	2,0	5,60	16100
DSH-35	35	33,0		1,60	1,00	1,50		32,2		5,6	3,9	2,5	4,000	3,0	30,80	17,8	2,0	5,55	15500

ALL DIMENSIONS IN MILLIMETERS.

\*The radius "R" on the load side must not exceed 0.1T.

\*\*\* FOR PLATED RINGS, ADD 0.05 TO THE LISTED MAXIMUM THICKNESS. MAXIMUM RING THICKNESS WILL BE A MINIMUM OF 0.005 LESS THAN THE LISTED GROOVE WIDTH (W) MINIMUM.  
FOR HARDNESS SPECIFICATIONS, SEE END OF SECTION.

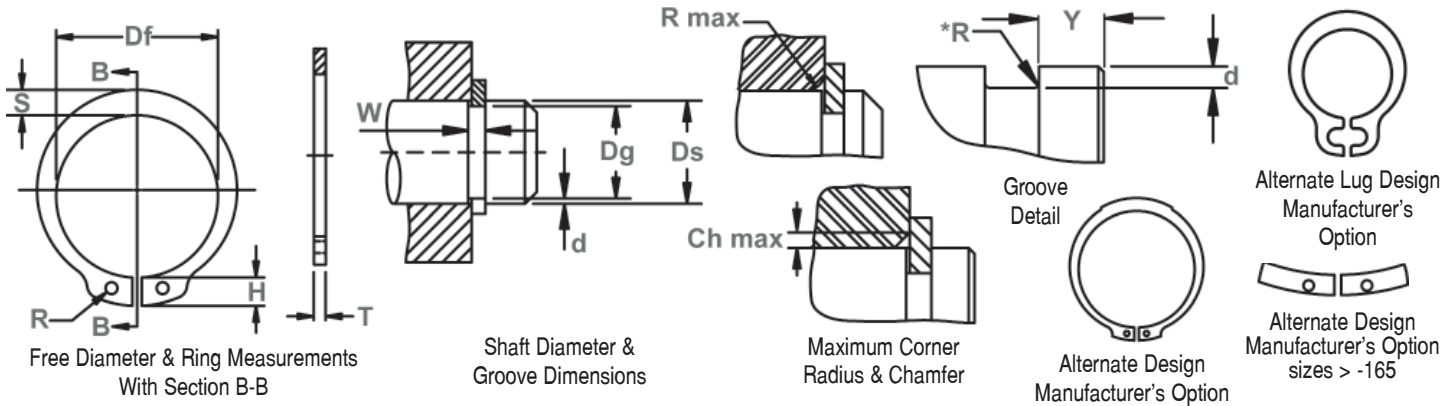

RING NO.	SHAFT DIA. (mm)	GROOVE SIZE					RING SIZE & WEIGHT						SUPPLEMENTARY DATA						
		DIAMETER		WIDTH	DEPTH	THICKNESS ***	FREE DIAMETER		LUG HT.	MAX. SEC.	HOLE DIA.	WEIGHT	EDGE MARGIN	THRUST LOAD Ring	THRUST LOAD Groove	Allowable Rad/ Cham.	Max. Load W/Ch Max.	RPM Limits	
		Ds	Dg	TOL.	W Min.	d	T	Tol.	Df	Tol.	H Max.	S Ref.	R Min.	kg/ 1000	Y Min.	Pr kN	Pg kN		R/Ch Max.
DSH-36	36	34,0		1,85	1,00	1,75		33,2		5,6	4,0	2,5	5,000	3,0	49,40	18,3	2,0	9,00	14500
DSH-37	37	35,0		1,85	1,00	1,75		34,2	+0,25	5,7	4,1	2,5	5,370	3,0	50,00	18,8	2,0	9,15	14100
DSH-38	38	36,0		1,85	1,00	1,75		35,2	-0,50	5,8	4,2	2,5	5,620	3,0	49,50	19,3	2,0	9,10	13600
DSH-39	39	37,0		1,85	1,00	1,75		36,0		5,9	4,3	2,5	5,850	3,0	49,80	19,9	2,0	9,25	14500
DSH-40	40	37,5		1,85	1,25	1,75		36,5		6,0	4,4	2,5	6,030	3,8	51,00	25,3	2,0	9,50	14300
DSH-41	41	38,5		1,85	1,25	1,75		37,5		6,2	4,5	2,5	6,215	3,8	50,10	26,0	2,0	9,40	13500
DSH-42	42	39,5	-0,25	1,85	1,25	1,75	-0,06	38,5	+0,39	6,5	4,5	2,5	6,500	3,8	50,00	26,7	2,0	9,45	13000
DSH-44	44	41,5		1,85	1,25	1,75		40,5	-0,90	6,6	4,6	2,5	7,000	3,8	48,50	28,0	2,0	9,20	11800
DSH-45	45	42,5		1,85	1,25	1,75		41,5		6,7	4,7	2,5	7,500	3,8	49,0	28,6	2,0	9,35	11400
DSH-46	46	43,5		1,85	1,25	1,75		42,5		6,7	4,8	2,5	7,600	3,8	48,9	29,4	2,0	9,40	10900
DSH-47	47	44,5		1,85	1,25	1,75		43,5		6,8	4,9	2,5	7,500	3,8	49,5	30,0	2,0	9,55	11000
DSH-48	48	45,5		1,85	1,25	1,75		44,5		6,9	5,0	2,5	7,900	3,8	49,4	30,7	2,0	9,55	10000
DSH-50	50	47,0		2,15	1,50	2,00		45,8		6,9	5,1	2,5	10,20	4,5	73,3	38,0	2,0	14,40	11000
DSH-52	52	49,0		2,15	1,50	2,00		47,8		7,0	5,2	2,5	11,10	4,5	73,1	39,7	2,5	11,50	10000
DSH-54	54	51,0		2,15	1,50	2,00		49,8		7,1	5,3	2,5	11,30	4,5	71,2	41,2	2,5	11,30	9000
DSH-55	55	52,0		2,15	1,50	2,00		50,8		7,2	5,4	2,5	11,40	4,5	71,4	42,0	2,5	11,40	9000
DSH-56	56	53,0		2,15	1,50	2,00		51,8		7,3	5,5	2,5	11,80	4,5	70,8	42,8	2,5	11,30	9000
DSH-57	57	54,0		2,15	1,50	2,00		52,8		7,3	5,5	2,5	12,20	4,5	70,9	43,7	2,5	11,40	8000
DSH-58	58	55,0		2,15	1,50	2,00		53,8		7,3	5,6	2,5	12,60	4,5	71,1	44,3	2,5	11,50	8000
DSH-60	60	57,0		2,15	1,50	2,00		55,8		7,4	5,8	2,5	12,90	4,5	69,2	46,0	2,5	11,30	8000
DSH-62	62	59,0		2,15	1,50	2,00	-0,07	57,8		7,5	6,0	2,5	14,30	4,5	69,3	47,5	2,5	11,40	7000
DSH-63	63	60,0	-0,30	2,15	1,50	2,00		58,8		7,6	6,2	2,5	15,90	4,5	70,2	48,3	2,5	11,60	7000
DSH-65	65	62,0		2,65	1,50	2,50		60,8		7,8	6,3	3,0	18,20	4,5	135,0	49,8	2,5	22,70	7000
DSH-67	67	64,0		2,65	1,50	2,50		62,5	+0,46	7,9	6,4	3,0	20,30	4,5	136,0	51,3	2,5	23,00	7000
DSH-68	68	65,0		2,65	1,50	2,50		63,5	-1,10	8,0	6,5	3,0	21,80	4,5	135,0	52,2	2,5	23,10	7000
DSH-70	70	67,0		2,65	1,50	2,50		65,5		8,1	6,6	3,0	22,00	4,5	134,0	53,8	2,5	23,00	7000
DSH-72	72	69,0		2,65	1,50	2,50		67,5		8,2	6,8	3,0	22,50	4,5	131,0	55,3	2,5	22,80	6000
DSH-75	75	72,0		2,65	1,50	2,50		70,5		8,4	7,0	3,0	24,60	4,5	130,0	57,6	2,5	22,80	6000
DSH-77	77	74,0		2,65	1,50	2,50		72,5		8,5	7,2	3,0	25,70	4,5	131,0	59,3	3,0	19,70	6000
DSH-78	78	75,0		2,65	1,50	2,50		73,5		8,6	7,3	3,0	26,20	4,5	131,0	60,0	3,0	19,70	5000
DSH-80	80	76,5		2,65	1,75	2,50		74,5		8,6	7,4	3,0	27,30	5,3	128,0	71,6	3,0	19,50	6000
DSH-82	82	78,5		2,65	1,75	2,50		76,5		8,7	7,6	3,0	31,20	5,3	128,0	73,5	3,0	19,60	6000
DSH-85	85	81,5	-0,35	3,15	1,75	3,00	-0,08	79,5		8,7	7,8	3,5	36,40	5,3	215,0	76,2	3,0	33,40	6000

ALL DIMENSIONS IN MILLIMETERS.

\*The radius "R" on the load side must not exceed 0.1T.

\*\*\* FOR PLATED RINGS, ADD 0.05 TO THE LISTED MAXIMUM THICKNESS. MAXIMUM RING THICKNESS WILL BE A MINIMUM OF 0.005 LESS THAN THE LISTED GROOVE WIDTH (W) MINIMUM. FOR HARDNESS SPECIFICATIONS, SEE END OF SECTION.



# DSH Shaft Rings

(DIN 471)

## Axially Assembled, External, Metric

Once installed in the groove of a shaft, the portion of the ring protruding from the groove (also called a "shoulder") holds an assembly in place.

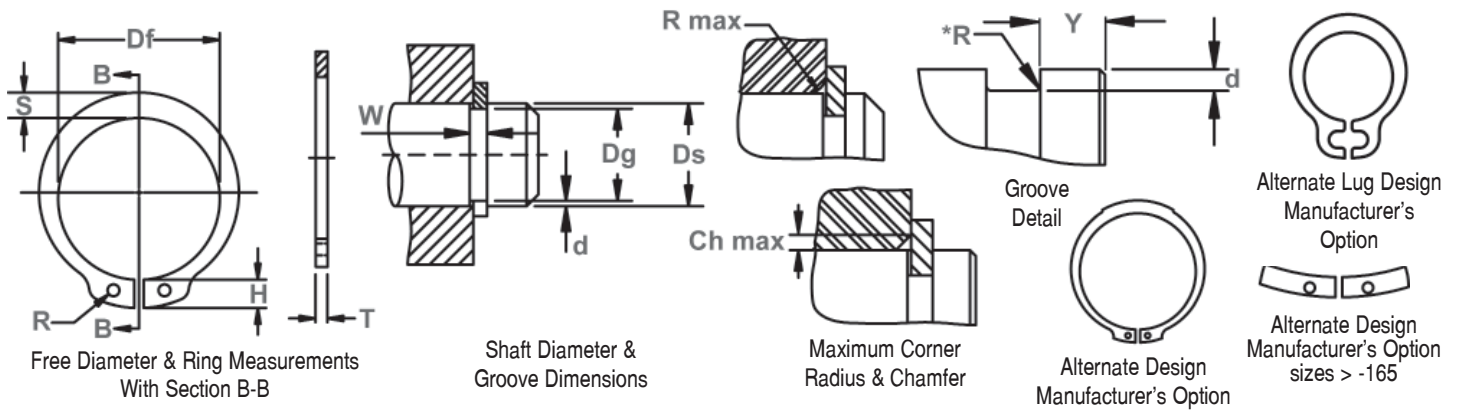

RING NO.	SHAFT DIA. (mm)	GROOVE SIZE				RING SIZE & WEIGHT						SUPPLEMENTARY DATA										
		DIAMETER		WIDTH	DEPTH	THICKNESS ***		FREE DIAMETER		LUG HT.	MAX. SEC.	HOLE DIA.	WEIGHT	EDGE MARGIN	THRUST LOAD Ring	THRUST LOAD Groove	Allowable Rad/Cham.	Max. Load w/Ch Max.	RPM Limits			
		Ds	Dg	TOL.	W Min.	d	T	Tol.	Df	Tol.	H Max.	S Ref.	R Min.	kg/1000	Y Min.	Pr kN	Pg kN	R/Ch Max.	P'r kN			
DSH-87	87	83,5	-0,35	3,15	1,75	3,00	-0,08	81,5		8,8	7,9	3,5	39,80	5,3	222,0	78,2	3,0	34,80	5000			
DSH-88	88	84,5		3,15	1,75	3,00		82,5		8,8	8,0	3,5	41,20	5,3	221,0	79,0	3,0	34,80	5000			
DSH-90	90	86,5		3,15	1,75	3,00		84,5		8,8	8,2	3,5	44,50	5,3	217,0	80,0	3,0	34,40	5000			
DSH-92	92	88,5		3,15	1,75	3,00		86,5		9,0	8,4	3,5	46,00	5,3	217,0	82,0	3,5	29,60	5000			
DSH-95	95	91,5		3,15	1,75	3,00		89,5		9,4	8,6	3,5	49,00	5,3	212,0	85,0	3,5	29,20	5000			
DSH-97	97	93,5		3,15	1,75	3,00		91,5		9,4	8,8	3,5	50,20	5,3	211,0	87,0	3,5	29,40	4000			
DSH-97	98	94,5		3,15	1,75	3,00		91,5		9,4	8,8	3,5	50,20	5,3	208,0	88,0	3,5	29,00	4000			
DSH-100	100	96,5		3,15	1,75	3,00		94,5		9,6	9,0	3,5	53,70	5,3	206,0	90,0	3,5	29,00	4000			
DSH-102	102	98,0		-0,54	4,15	2,00		4,00		-0,10	95,0		9,7	9,2	3,5	78,00	6,0	482,0	104,0	3,5	68,50	5000
DSH-105	105	101,0			4,15	2,00		4,00			98,0		+0,54	9,9	9,9	3,5	80,00	6,0	471,0	107,0	3,5	67,70
DSH-107	107	103,0	4,15		2,00	4,00	100,0	-1,30	10,0		9,5		3,5	81,00	6,0	465,0	110,0	3,5	67,30	5000		
DSH-107	108	104,0	4,15		2,00	4,00	100,0	10,0	9,5		3,5		81,00	6,0	459,0	111,0	3,5	66,30	4000			
DSH-110	110	106,0	4,15		2,00	4,00	103,0	10,1	9,6		3,5		82,00	6,0	457,0	113,0	3,5	66,90	4000			
DSH-112	112	108,0	4,15		2,00	4,00	105,0	10,3	9,7		3,5		83,00	6,0	451,0	115,0	3,5	66,60	4000			
DSH-115	115	111,0	4,15		2,00	4,00	108,0	10,6	9,8		3,5		84,00	6,0	438,0	118,0	3,5	65,50	4000			
DSH-117	117	113,0	4,15		2,00	4,00	110,0	10,8	10,0		3,5		85,00	6,0	437,0	120,0	3,5	65,60	4000			
DSH-117	118	114,0	4,15		2,00	4,00	110,0	10,8	10,0		3,5		85,00	6,0	430,0	121,0	3,5	64,80	4000			
DSH-120	120	116,0	4,15		2,00	4,00	113,0	11,0	10,2		3,5		86,00	6,0	424,0	123,0	3,5	64,50	4000			
DSH-122	122	118,0	4,15	2,00	4,00	115,0	11,2	10,3	4,0	88,00	6,0	418,0	125,0	4,0	56,60	4000						
DSH-125	125	121,0	-0,63	4,15	2,00	4,00	-0,10	118,0		11,4	10,4	4,0	90,00	6,0	411,0	128,0	4,0	56,50	3000			
DSH-127	127	123,0		4,15	2,00	4,00		120,0		11,4	10,5	4,0	95,00	6,0	407,0	130,0	4,0	56,10	3000			
DSH-127	128	124,0		4,15	2,00	4,00		120,0		11,4	10,5	4,0	95,00	6,0	401,0	131,0	4,0	55,60	3000			
DSH-130	130	126,0		4,15	2,00	4,00		123,0		11,6	10,7	4,0	100,0	6,0	395,0	134,0	4,0	55,20	3000			
DSH-132	132	128,0		4,15	2,00	4,00		125,0		11,7	10,8	4,0	103,0	6,0	396,0	136,0	4,0	55,60	3000			
DSH-135	135	131,0		4,15	2,00	4,00		128,0		11,8	11,0	4,0	104,0	6,0	389,0	139,0	4,0	55,40	3000			
DSH-137	137	133,0		4,15	2,00	4,00		130,0		11,9	11,0	4,0	107,0	6,0	380,0	141,0	4,0	54,40	3000			
DSH-137	138	134,0		4,15	2,00	4,00		130,0		+0,63	11,9	11,0	4,0	107,0	6,0	381,0	142,0	4,0	54,70	3000		
DSH-140	140	136,0		4,15	2,00	4,00		133,0		-1,50	12,0	11,2	4,0	110,0	6,0	376,0	144,0	4,0	54,40	3000		
DSH-142	142	138,0		4,15	2,00	4,00		135,0		12,1	11,3	4,0	112,0	6,0	370,0	146,0	4,0	54,00	3000			
DSH-145	145	141,0	4,15	2,00	4,00	138,0	12,2	11,5	4,0	115,0	6,0	367,0	149,0	4,0	53,80	3000						
DSH-147	147	143,0	4,15	2,00	4,00	140,0	12,3	11,6	4,0	116,0	6,0	361,0	151,0	4,0	53,50	3000						
DSH-147	148	144,0	4,15	2,00	4,00	140,0	12,3	11,6	4,0	116,0	6,0	357,0	152,0	4,0	53,00	2000						
DSH-150	150	145,0	4,15	2,50	4,00	142,0	13,0	11,8	4,0	120,0	7,5	357,0	193,0	4,0	53,40	2000						

ALL DIMENSIONS IN MILLIMETERS.

\*The radius "R" on the load side must not exceed 0.1T.

\*\*\* FOR PLATED RINGS, ADD 0.05 TO THE LISTED MAXIMUM THICKNESS. MAXIMUM RING THICKNESS WILL BE A MINIMUM OF 0.005 LESS THAN THE LISTED GROOVE WIDTH (W) MINIMUM. FOR HARDNESS SPECIFICATIONS, SEE END OF SECTION.

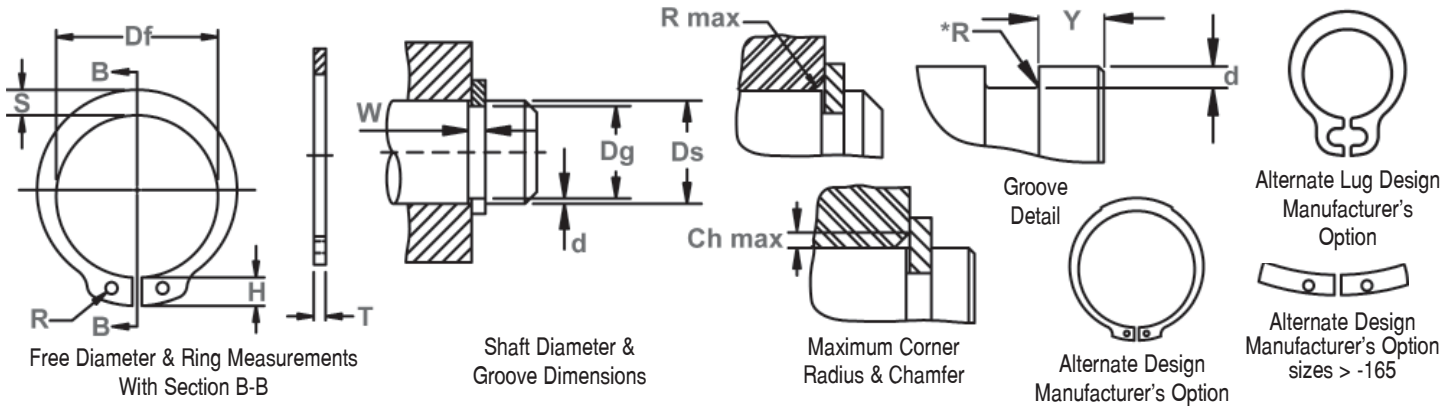

RING NO.	SHAFT DIA. (mm)		GROOVE SIZE					RING SIZE & WEIGHT							SUPPLEMENTARY DATA					
	Ds	Dg	TOL.	W Min.	d	THICKNESS ***		FREE DIAMETER		LUG HT.	MAX. SEC.	HOLE DIA.		WEIGHT	EDGE MARGIN	THRUST LOAD Ring	THRUST LOAD Groove	Allowable Rad/Cham.	Max. Load w/Ch Max.	RPM Limits
						T	Tol.	Df	Tol.			H Max.	S Ref.							
DSH-152	152	147.0		4,15	2,50	4,00		143,0		13,0	11,9	4,0	128,0	7,5	356,0	195,0	4,0	53,10	3000	
DSH-155	155	150,0		4,15	2,50	4,00		146,0		13,0	12,0	4,0	135,0	7,5	352,0	199,0	4,0	52,60	3000	
DSH-157	157	152,0		4,15	2,50	4,00		148,0		13,1	12,0	4,0	140,0	7,5	352,0	202,0	4,0	52,50	3000	
DSH-157	158	153,0		4,15	2,50	4,00		148,0		13,1	12,0	4,0	140,0	7,5	353,0	203,0	4,0	52,70	3000	
DSH-160	160	155,0		4,15	2,50	4,00		151,0		13,3	12,2	4,0	150,0	7,5	349,0	206,0	4,0	52,20	3000	
DSH-162	162	157,0		4,15	2,50	4,00		152,5		13,3	12,3	4,0	155,0	7,5	348,0	208,0	5,0	41,70	3000	
DSH-165	165	160,0		4,15	2,50	4,00		155,5		13,5	12,5	4,0	160,0	7,5	345,0	212,0	5,0	41,40	3000	
DSH-167	167	162,0		4,15	2,50	4,00		157,5		13,5	12,9	4,0	163,0	7,5	354,0	215,0	5,0	42,50	3000	
DSH-167	168	163,0	-0,63	4,15	2,50	4,00	-0,10	157,5	+0,63	13,5	12,9	4,0	163,0	7,5	353,0	216,0	5,0	42,40	2000	
DSH-170	170	165,0		4,15	2,50	4,00		160,5	-1,50	13,5	12,9	4,0	170,0	7,5	349,0	219,0	5,0	41,90	2000	
DSH-170	172	167,0		4,15	2,50	4,00		160,5		13,5	12,9	4,0	170,0	7,5	344,0	221,0	5,0	41,30	2000	
DSH-175	175	170,0		4,15	2,50	4,00		165,5		13,5	12,9	4,0	180,0	7,5	340,0	225,0	5,0	40,70	2000	
DSH-177	177	172,0		4,15	2,50	4,00		167,5		14,2	13,5	4,0	183,0	7,5	335,0	228,0	5,0	40,20	2000	
DSH-177	178	173,0		4,15	2,50	4,00		167,5		14,2	13,5	4,0	183,0	7,5	349,0	229,0	5,0	42,00	2000	
DSH-180	180	175,0		4,15	2,50	4,00		170,5		14,2	13,5	4,0	190,0	7,5	345,0	232,0	5,0	41,40	2000	
DSH-180	182	177,0		4,15	2,50	4,00		170,5		14,2	13,5	4,0	190,0	7,5	341,0	235,0	5,0	41,00	2000	
DSH-185	185	180,0		4,15	2,50	4,00		175,5		14,2	13,5	4,0	200,0	7,5	336,0	238,0	5,0	40,40	2000	
DSH-187	187	182,0		4,15	2,50	4,00		177,5		14,2	14,0	4,0	203,0	7,5	338,0	241,0	5,0	40,50	2000	
DSH-187	188	183,0		4,15	2,50	4,00		177,5		14,2	14,0	4,0	203,0	7,5	337,0	242,0	5,0	40,60	2000	
DSH-190	190	185,0		4,15	2,50	4,00		180,5		14,2	14,0	4,0	210,0	7,5	333,0	245,0	5,0	40,00	2000	
DSH-190	192	187,0		4,15	2,50	4,00		180,5		14,2	14,0	4,0	210,0	7,5	330,0	248,0	5,0	39,60	2000	
DSH-195	195	190,0		4,15	2,50	4,00		185,5		14,2	14,0	4,0	220,0	7,5	325,0	251,0	5,0	39,00	2000	
DSH-197	197	192,0		4,15	2,50	4,00		187,5		14,2	14,0	4,0	223,0	7,5	322,0	254,0	5,0	38,60	2000	
DSH-197	198	193,0		4,15	2,50	4,00		187,5		14,2	14,0	4,0	223,0	7,5	322,0	255,0	5,0	38,70	2000	
DSH-200	200	195,0		4,15	2,50	4,00		190,5	+0,72	14,2	14,0	4,0	230,0	7,5	319,0	258,0	5,0	38,30	2000	
DSH-202	202	196,0	-0,72	5,15	3,00	5,00	-0,12	190,0	-1,70	14,2	14,0	4,0	235,0	9,0	624,0	312,0	6,0	62,50	2000	
DSH-205	205	199,0		5,15	3,00	5,00		193,0		14,2	14,0	4,0	243,0	9,0	611,0	317,0	6,0	61,30	2000	
DSH-205	207	201,0		5,15	3,00	5,00		193,0		14,2	14,0	4,0	243,0	9,0	608,0	320,0	6,0	60,90	2000	
DSH-205	208	202,0		5,15	3,00	5,00		193,0		14,2	14,0	4,0	243,0	9,0	605,0	321,0	6,0	60,50	2000	
DSH-210	210	204,0		5,15	3,00	5,00		198,0		14,2	14,0	4,0	248,0	9,0	598,0	325,0	6,0	59,90	2000	
DSH-210	212	206,0		5,15	3,00	5,00		198,0		14,2	14,0	4,0	248,0	9,0	593,0	328,0	6,0	59,50	2000	
DSH-215	215	209,0		5,15	3,00	5,00		203,0		14,2	14,0	4,0	260,0	9,0	585,0	332,0	6,0	58,50	2000	
DSH-215	217	211,0		5,15	3,00	5,00		203,0		14,2	14,0	4,0	260,0	9,0	580,0	336,0	6,0	58,10	2000	
DSH-215	218	212,0		5,15	3,00	5,00		203,0		14,2	14,0	4,0	260,0	9,0	577,0	337,0	6,0	57,80	2000	

ALL DIMENSIONS IN MILLIMETERS.

\*The radius "R" on the load side must not exceed 0.1T.

\*\*\* FOR PLATED RINGS, ADD 0.05 TO THE LISTED MAXIMUM THICKNESS. MAXIMUM RING THICKNESS WILL BE A MINIMUM OF 0.005

LESS THAN THE LISTED GROOVE WIDTH (W) MINIMUM.

FOR HARDNESS SPECIFICATIONS, SEE END OF SECTION.



# DSH Shaft Rings

(DIN 471)

## Axially Assembled, External, Metric

Once installed in the groove of a shaft, the portion of the ring protruding from the groove (also called a "shoulder") holds an assembly in place.

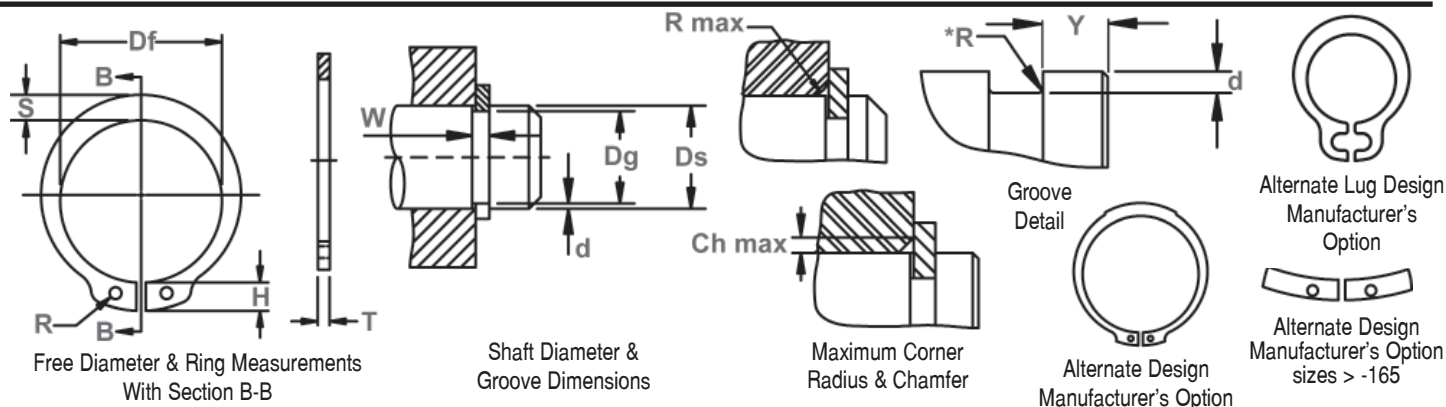

RING NO.	SHAFT DIA. (mm)		GROOVE SIZE					RING SIZE & WEIGHT						SUPPLEMENTARY DATA						
			DIAMETER		WIDTH	DEPTH	THICKNESS ***		FREE DIAMETER		LUG HT.	MAX. SEC.	HOLE DIA.	WEIGHT	EDGE MARGIN	THRUST LOAD Ring	THRUST LOAD Groove	Allowable Rad/Cham.	Max. Load w/Ch Max.	RPM Limits
			Ds	Dg	TOL.	W Min.	d	T	Tol.	Df	Tol.	H Max.	S Ref.	R Min.	kg/1000	Y Min.	Pr kN	Pg kN	R/Ch Max.	
DSH-220	220	214,0		5,15	3,00	5,00		208,0		14,2	14,0	4,0	265,0	9,0	572,0	340,0	6,0	57,30	2000	
DSH-220	222	216,0		5,15	3,00	5,00		208,0		14,2	14,0	4,0	265,0	9,0	567,0	343,0	6,0	56,80	2000	
DSH-225	225	219,0		5,15	3,00	5,00		213,0		14,2	14,0	4,0	280,0	9,0	559,0	349,0	6,0	56,00	2000	
DSH-225	227	221,0		5,15	3,00	5,00		213,0		14,2	14,0	4,0	280,0	9,0	555,0	351,0	6,0	55,50	1000	
DSH-225	228	222,0		5,15	3,00	5,00		213,0		14,2	14,0	4,0	280,0	9,0	552,0	353,0	6,0	55,40	1000	
DSH-230	230	224,0		5,15	3,00	5,00		218,0		14,2	14,0	4,0	290,0	9,0	548,0	356,0	6,0	55,00	1000	
DSH-230	232	226,0		5,15	3,00	5,00		218,0		14,2	14,0	4,0	290,0	9,0	543,0	359,0	6,0	54,50	1000	
DSH-235	235	229,0		5,15	3,00	5,00		223,0		14,2	14,0	4,0	305,0	9,0	537,0	364,0	6,0	53,80	1000	
DSH-235	237	231,0	-0,72	5,15	3,00	5,00	-0,12	223,0	+0,72	14,2	14,0	4,0	305,0	9,0	532,0	367,0	6,0	53,40	1000	
DSH-235	238	232,0		5,15	3,00	5,00		223,0	-1,70	14,2	14,0	4,0	305,0	9,0	530,0	369,0	6,0	53,00	1000	
DSH-240	240	234,0		5,15	3,00	5,00		228,0		14,2	14,0	4,0	310,0	9,0	530,0	372,0	6,0	53,00	1000	
DSH-240	242	236,0		5,15	3,00	5,00		228,0		14,2	14,0	4,0	310,0	9,0	520,0	375,0	6,0	52,20	1000	
DSH-245	245	239,0		5,15	3,00	5,00		233,0		14,2	14,0	4,0	325,0	9,0	515,0	380,0	6,0	51,50	1000	
DSH-245	247	241,0		5,15	3,00	5,00		233,0		14,2	14,0	4,0	325,0	9,0	511,0	383,0	6,0	51,20	1000	
DSH-245	248	242,0		5,15	3,00	5,00		233,0		14,2	14,0	4,0	325,0	9,0	508,0	385,0	6,0	50,90	1000	
DSH-250	250	244,0		5,15	3,00	5,00		238,0		14,2	14,0	4,0	335,0	9,0	504,0	388,0	6,0	50,50	1000	
DSH-250	252	244,0		5,15	4,00	5,00		238,0		16,2	16,0	5,0	335,0	12,0	563,0	519,0	6,0	56,40	1000	
DSH-255	255	247,0		5,15	4,00	5,00		240,0		16,2	16,0	5,0	348,0	12,0	557,0	525,0	6,0	55,70	1000	
DSH-255	257	249,0		5,15	4,00	5,00		240,0		16,2	16,0	5,0	348,0	12,0	551,0	529,0	6,0	55,20	1000	
DSH-255	258	250,0		5,15	4,00	5,00		240,0		16,2	16,0	5,0	348,0	12,0	550,0	531,0	6,0	55,10	1000	
DSH-260	260	252,0	-0,81	5,15	4,00	5,00		245,0		16,2	16,0	5,0	355,0	12,0	540,0	535,0	6,0	54,60	1000	
DSH-260	262	254,0		5,15	4,00	5,00		245,0		16,2	16,0	5,0	355,0	12,0	542,0	540,0	6,0	54,40	1000	

ALL DIMENSIONS IN MILLIMETERS.

\*The radius "R" on the load side must not exceed 0.1T.

\*\*\* FOR PLATED RINGS, ADD 0.05 TO THE LISTED MAXIMUM THICKNESS. MAXIMUM RING THICKNESS WILL BE A MINIMUM OF 0.005 LESS THAN THE LISTED GROOVE WIDTH (W) MINIMUM. FOR HARDNESS SPECIFICATIONS, SEE END OF SECTION.





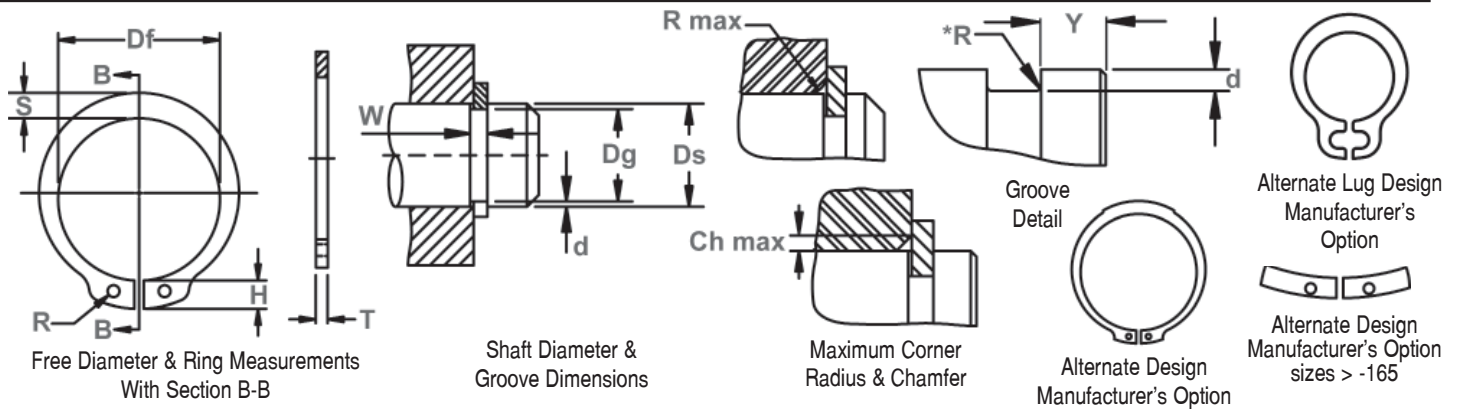

RING NO.	SHAFT DIA. (mm)		GROOVE SIZE				RING SIZE & WEIGHT						SUPPLEMENTARY DATA						
			DIAMETER		WIDTH	DEPTH	THICKNESS ***		FREE DIAMETER		LUG HT.	MAX. SEC.	HOLE DIA.	WEIGHT	EDGE MARGIN	THRUST LOAD Ring	THRUST LOAD Groove	Allowable Rad/Cham.	Max. Load w/Ch Max.
	Ds	Dg	TOL.	W Min.	d	T	Tol.	Df	Tol.	H Max.	S Ref.	R Min.	kg/1000	Y Min.	Pr kN	Pg kN	R/Ch Max.	P'r kN	
DSH-265	265	257.0		5,15	4,00	5,00		250,0	+0,72	16,2	16,0	5,0	370,0	12,0	536,0	546,0	6,0	53,70	1000
DSH-265	267	259,0		5,15	4,00	5,00		250,0	-1,70	16,2	16,0	5,0	370,0	12,0	532,0	550,0	6,0	53,30	1000
DSH-265	268	260,0		5,15	4,00	5,00		250,0		16,2	16,0	5,0	370,0	12,0	529,0	553,0	6,0	53,00	1000
DSH-270	270	262,0		5,15	4,00	5,00		255,0		16,2	16,0	5,0	375,0	12,0	525,0	556,0	6,0	52,50	1000
DSH-270	272	264,0		5,15	4,00	5,00		255,0		16,2	16,0	5,0	375,0	12,0	522,0	560,0	6,0	52,00	1000
DSH-275	275	267,0		5,15	4,00	5,00		260,0		16,2	16,0	5,0	390,0	12,0	516,0	566,0	6,0	51,00	1000
DSH-275	277	269,0		5,15	4,00	5,00		260,0		16,2	16,0	5,0	390,0	12,0	513,0	571,0	6,0	51,00	1000
DSH-275	278	270,0		5,15	4,00	5,00		260,0		16,2	16,0	5,0	390,0	12,0	510,0	574,0	6,0	51,00	1000
DSH-280	280	272,0		5,15	4,00	5,00		265,0		16,2	16,0	5,0	398,0	12,0	508,0	576,0	6,0	50,00	1000
DSH-280	282	274,0	-0,81	5,15	4,00	5,00	-0,12	265,0		16,2	16,0	5,0	398,0	12,0	503,0	580,0	6,0	50,00	1000
DSH-285	285	277,0		5,15	4,00	5,00		270,0	+0,81	16,2	16,0	5,0	410,0	12,0	499,0	587,0	6,0	50,00	1000
DSH-285	287	279,0		5,15	4,00	5,00		270,0	-2,00	16,2	16,0	5,0	410,0	12,0	494,0	591,0	6,0	49,00	1000
DSH-285	288	280,0		5,15	4,00	5,00		270,0		16,2	16,0	5,0	410,0	12,0	493,0	594,0	6,0	49,00	1000
DSH-290	290	282,0		5,15	4,00	5,00		275,0		16,2	16,0	5,0	418,0	12,0	490,0	599,0	6,0	49,00	1000
DSH-290	292	284,0		5,15	4,00	5,00		275,0		16,2	16,0	5,0	418,0	12,0	487,0	603,0	6,0	48,00	1000
DSH-295	295	287,0		5,15	4,00	5,00		280,0		16,2	16,0	5,0	430,0	12,0	481,0	609,0	6,0	48,00	1000
DSH-295	297	289,0		5,15	4,00	5,00		280,0		16,2	16,0	5,0	430,0	12,0	479,0	613,0	6,0	48,00	1000
DSH-295	298	290,0		5,15	4,00	5,00		280,0		16,2	16,0	5,0	430,0	12,0	476,0	615,0	6,0	47,00	1000
DSH-300	300	292,0		5,15	4,00	5,00		285,0		16,2	16,0	5,0	440,0	12,0	475,0	619,0	6,0	47,00	1000
DSH-305	305	295,0		6,20	5,00	6,00		288,0		20,2	20,0	6,0	738,0	15,0	1036,0	785,0	7,0	89,00	1000
DSH-310	310	300,0		6,20	5,00	6,00	-0,15	293,0		20,2	20,0	6,0	750,0	15,0	1016,0	796,0	7,0	87,00	1000
DSH-315	315	305,0		6,20	5,00	6,00		298,0		20,2	20,0	6,0	760,0	15,0	1007,0	811,0	7,0	86,00	1000

ALL DIMENSIONS IN MILLIMETERS.

\*The radius "R" on the load side must not exceed 0.1T.

\*\*\* FOR PLATED RINGS, ADD 0.05 TO THE LISTED MAXIMUM THICKNESS. MAXIMUM RING THICKNESS WILL BE A MINIMUM OF 0.005 LESS THAN THE LISTED GROOVE WIDTH (W) MINIMUM. FOR HARDNESS SPECIFICATIONS, SEE END OF SECTION.



# DSH Shaft Rings

(DIN 471)

## Axially Assembled, External, Metric

Once installed in the groove of a shaft, the portion of the ring protruding from the groove (also called a "shoulder") holds an assembly in place.

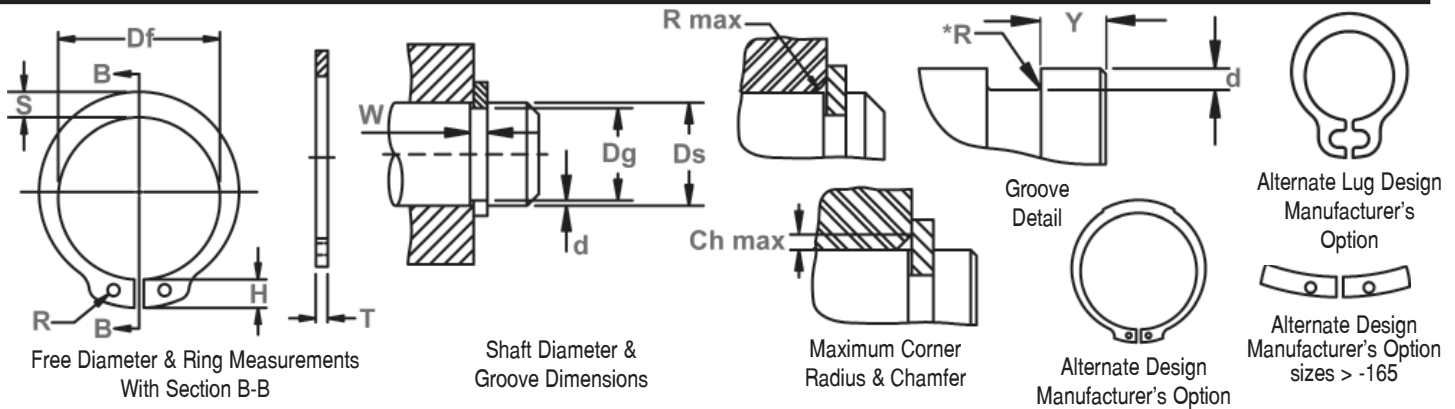

RING NO.	SHAFT DIA. (mm)	GROOVE SIZE					RING SIZE & WEIGHT							SUPPLEMENTARY DATA						
		DIAMETER		WIDTH	DEPTH		THICKNESS ***		FREE DIAMETER		LUG HT.	MAX. SEC.	HOLE DIA.	WEIGHT	EDGE MARGIN	THRUST LOAD Ring	THRUST LOAD Groove	Allowable Rad/Cham.	Max. Load w/Ch Max.	RPM Limits
		Ds	Dg	TOL.	W Min.	d	T	Tol.	Df	Tol.	H Max.	S Ref.	R Min.	kg/1000	Y Min.	Pr kN	Pg kN	R/Ch Max.	Pr kN	
DSH-320	320	310,0	-0,81	6,20	5,00	6,00		303,0	+0,81	20,2	20,0	6,0	770,0	15,0	988,0	825,0	7,0	85,00	1000	
DSH-325	325	315,0		6,20	5,00	6,00		308,0	-2,00	20,2	20,0	6,0	787,0	15,0	975,0	837,0	7,0	83,00	1000	
DSH-330	330	320,0		6,20	5,00	6,00		313,0		20,2	20,0	6,0	800,0	15,0	958,0	850,0	7,0	82,00	1000	
DSH-335	335	325,0		6,20	5,00	6,00		318,0		20,2	20,0	6,0	826,0	15,0	945,0	864,0	7,0	81,00	1000	
DSH-340	340	330,0		6,20	5,00	6,00		323,0		20,2	20,0	6,0	840,0	15,0	932,0	876,0	7,0	80,00	1000	
DSH-345	345	335,0		6,20	5,00	6,00		328,0		20,2	20,0	6,0	845,0	15,0	917,0	890,0	7,0	79,00	1000	
DSH-350	350	340,0		6,20	5,00	6,00		333,0		20,2	20,0	6,0	850,0	15,0	906,0	903,0	7,0	77,00	1000	
DSH-355	355	345,0		6,20	5,00	6,00		338,0		20,2	20,0	6,0	865,0	15,0	894,0	916,0	7,0	76,00	1000	
DSH-360	360	350,0	-0,89	6,20	5,00	6,00	-0,15	343,0		20,2	20,0	6,0	880,0	15,0	880,0	928,0	7,0	75,00	1000	
DSH-365	365	355,0		6,20	5,00	6,00		348,0		20,2	20,0	6,0	885,0	15,0	868,0	942,0	7,0	74,00	1000	
DSH-370	370	360,0		6,20	5,00	6,00		353,0	+0,90	20,2	20,0	6,0	890,0	15,0	856,0	955,0	7,0	73,00	1000	
DSH-375	375	365,0		6,20	5,00	6,00		358,0	-2,00	20,2	20,0	6,0	910,0	15,0	847,0	968,0	7,0	72,00	1000	
DSH-380	380	370,0		6,20	5,00	6,00		363,0		20,2	20,0	6,0	930,0	15,0	833,0	980,0	7,0	71,00	1000	
DSH-385	385	375,0		6,20	5,00	6,00		368,0		20,2	20,0	6,0	940,0	15,0	823,0	994,0	7,0	70,00	1000	
DSH-390	390	380,0		6,20	5,00	6,00		373,0		20,2	20,0	6,0	950,0	15,0	814,0	1008,0	7,0	70,00	1000	
DSH-395	395	385,0		6,20	5,00	6,00		378,0		20,2	20,0	6,0	990,0	15,0	803,0	1021,0	7,0	69,00	1000	
DSH-400	400	390,0		6,20	5,00	6,00		383,0		20,2	20,0	6,0	1040,0	15,0	793,0	1033,0	7,0	69,00	1000	
DSH-410	410	398,0		7,20	6,00	7,00		390,0		26,2	26,0	6,0	1320,0	18,0	1616,0	1269,0	7,0	139,0	1000	
DSH-420	420	408,0		7,20	6,00	7,00		400,0		26,2	26,0	6,0	1360,0	18,0	1569,0	1300,0	7,0	135,0	1000	
DSH-430	430	418,0	-1,00	7,20	6,00	7,00		410,0	+1,00	26,2	26,0	6,0	1390,0	18,0	1540,0	1332,0	7,0	132,0	1000	
DSH-440	440	428,0		7,20	6,00	7,00		420,0	-2,00	26,2	26,0	6,0	1420,0	18,0	1500,0	1363,0	7,0	129,0	1000	
DSH-450	450	438,0		7,20	6,00	7,00		430,0		26,2	26,0	6,0	1450,0	18,0	1472,0	1393,0	7,0	126,0	1000	

ALL DIMENSIONS IN MILLIMETERS.

\*The radius "R" on the load side must not exceed 0.1T.

\*\*\* FOR PLATED RINGS, ADD 0.05 TO THE LISTED MAXIMUM THICKNESS. MAXIMUM RING THICKNESS WILL BE A MINIMUM OF 0.005 LESS THAN THE LISTED GROOVE WIDTH (W) MINIMUM.

HARDNESS RANGES: STAINLESS STEEL RINGS (DIN 1.4122 X39CrMo17)

RING TYPE	SIZE RANGE	HARDNESS			
		HV	HRC	15N	30N
DSH	ALL	470-580	47-54	84-87.5	66-72



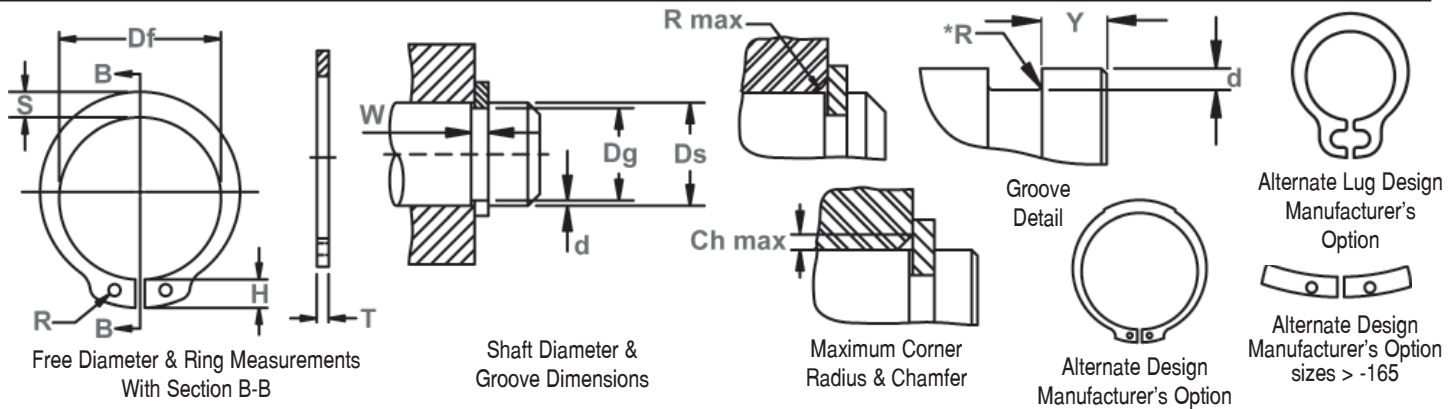

RING NO.	SHAFT DIA. (mm)	GROOVE SIZE					RING SIZE & WEIGHT						SUPPLEMENTARY DATA						
		DIAMETER		WIDTH	DEPTH	THICKNESS ***	FREE DIAMETER		LUG HT.	MAX. SEC.	HOLE DIA.	WEIGHT	EDGE MARGIN	THRUST LOAD Ring	THRUST LOAD Groove	Allowable Rad/Cham.	Max. Load w/Ch Max.	RPM Limits	
		Ds	Dg TOL.	W Min.	d	T Tol.	Df Tol.	H Max.	S Ref.	R Min.	kg/1000	Y Min.	Pr kN	Pg kN	R/Ch Max.	P'r kN			
DSH-460	460	448,0		7,20	6,00	7,00		440,0		26,2	26,0	6,0	1520,0	18,0	1443,0	1426,0	7,0	124,0	1000
DSH-470	470	458,0		7,20	6,00	7,00		450,0		26,2	26,0	6,0	1590,0	18,0	1413,0	1457,0	7,0	121,0	1000
DSH-480	480	468,0		7,20	6,00	7,00		460,0		26,2	26,0	6,0	1660,0	18,0	1383,0	1489,0	7,0	119,0	500
DSH-490	490	478,0		7,20	6,00	7,00		470,0	+1,00	26,2	26,0	6,0	1725,0	18,0	1355,0	1520,0	7,0	116,0	500
DSH-500	500	488,0		7,20	6,00	7,00		480,0	-2,00	26,2	26,0	6,0	1790,0	18,0	1329,0	1550,0	7,0	114,0	500
DSH-510	510	496,0		8,20	7,00	8,00		485,0		26,2	26,0	6,0	2300,0	21,0	1952,0	1843,0	7,0	167,0	1000
DSH-520	520	506,0		8,20	7,00	8,00	-0,15	495,0		26,2	26,0	6,0	2350,0	21,0	1910,0	1880,0	7,0	164,0	500
DSH-530	530	516,0		8,20	7,00	8,00		505,0		26,2	26,0	6,0	2400,0	21,0	1878,0	1916,0	7,0	161,0	500
DSH-540	540	526,0		8,20	7,00	8,00		515,0		26,2	26,0	6,0	2445,0	21,0	1846,0	1953,0	7,0	158,0	400
DSH-550	550	536,0	-1,00	8,20	7,00	8,00		525,0		26,2	26,0	6,0	2490,0	21,0	1812,0	1986,0	7,0	155,0	400
DSH-560	560	546,0		8,20	7,00	8,00		535,0		26,2	26,0	6,0	2580,0	21,0	1777,0	2026,0	7,0	153,0	400
DSH-570	570	556,0		8,20	7,00	8,00		545,0	+1,50	26,2	26,0	6,0	2670,0	21,0	1750,0	2063,0	7,0	150,0	400
DSH-580	580	566,0		8,20	7,00	8,00		555,0	-3,00	26,2	26,0	6,0	2760,0	21,0	1718,0	2100,0	7,0	147,0	400
DSH-590	590	576,0		8,20	7,00	8,00		565,0		26,2	26,0	6,0	2840,0	21,0	1689,0	2136,0	7,0	145,0	400
DSH-600	600	586,0		8,20	7,00	8,00		575,0		26,2	26,0	6,0	2920,0	21,0	1600,0	2170,0	7,0	143,0	300
DSH-650	650	634,0		9,30	8,00	9,00		620,0		34,0	34,0	6,0	3770,0	24,0	2810,0	2640,0	7,0	242,0	400
DSH-700**	700	684,0		9,30	8,00	9,00		670,0		34,0	34,0	6,0	4070,0	24,0	2615,0	2890,0	7,0	225,0	300
DSH-750**	750	732,0		9,30	9,00	9,00		715,0		34,0	34,0	9,0	4640,0	27,0	2450,0	3490,0	7,0	207,0	190
DSH-800**	800	782,0		9,30	9,00	9,00	-0,2	765,0		34,0	34,0	9,0	5330,0	27,0	2299,0	3730,0	7,0	195,0	300
DSH-850**	850	830,0		9,30	10,00	9,00		810,0		34,0	34,0	9,0	6030,0	30,0	2166,0	4400,0	7,0	183,0	300
DSH-900**	900	880,0		9,30	10,00	9,00		860,0	+2,00	34,0	34,0	9,0	6640,0	30,0	2047,0	4650,0	7,0	173,0	200
DSH-950**	950	928,0		9,30	11,00	9,00		900,0	-4,00	34,0	34,0	9,0	7260,0	33,0	1945,0	5400,0	7,0	165,0	200
DSH-1000**	1000	978,0		9,30	11,00	9,00		950,0		34,0	34,0	9,0	8130,0	33,0	1851,0	5700,0	7,0	157,0	200

ALL DIMENSIONS IN MILLIMETERS.

\*The radius "R" on the load side must not exceed 0.1T.

\*\* THESE PARTS ARE MADE WITH A CONSTANT SECTION WIDTH (NO TAPER)

\*\*\* FOR PLATED RINGS, ADD 0.05 TO THE LISTED MAXIMUM THICKNESS. MAXIMUM RING THICKNESS WILL BE A MINIMUM OF 0.005 LESS THAN THE LISTED GROOVE WIDTH (W) MINIMUM.

HARDNESS RANGES: STAINLESS STEEL RINGS (PH 15-7MO)

RING TYPE	SIZE RANGE	HARDNESS		
		VICKERS	ROCKWELL	
			HRC	LOWER SCALE*
DSH	3 & 4	435-530	44-51	82.5-86 HR30N**
	5-17	435-530	44-51	63-69.5 HR30N
	18-1000	435-530	44-51	-

\*WHERE APPLICABLE

\*\* HARDNESS CAN NOT BE CHECKED WITH ANY DEGREE OF ACCURACY DIRECTLY ON THESE RINGS.

HARDNESS RANGES: CARBON STEEL RINGS (SAE 1060-1090)

RING TYPE	SIZE RANGE	HARDNESS		
		VICKERS	ROCKWELL	
			HRC	LOWER SCALE*
DSH	3 & 4	470-580	47-54	84-87.5 HR30N**
	5-17	470-580	47-54	66-72 HR30N
	18-48	470-580	47-54	-
	50-200	435-530	44-51	-
	202-300	390-470	40-47	-
	305-1000	370-415	38-43	-

\*WHERE APPLICABLE

\*\*HARDNESS CAN NOT BE CHECKED WITH ANY DEGREE OF ACCURACY DIRECTLY ON THESE RINGS.



# DSI Shaft Rings

## Axially Assembled, External Inverted, Metric

Functions like a DSH ring in a shaft, only the lugs are "reversed."

This version reduces the distance the lugs of the standard DSH extend beyond the circumference of the shaft. The shaft can then be used in an application where clearance is minimal.

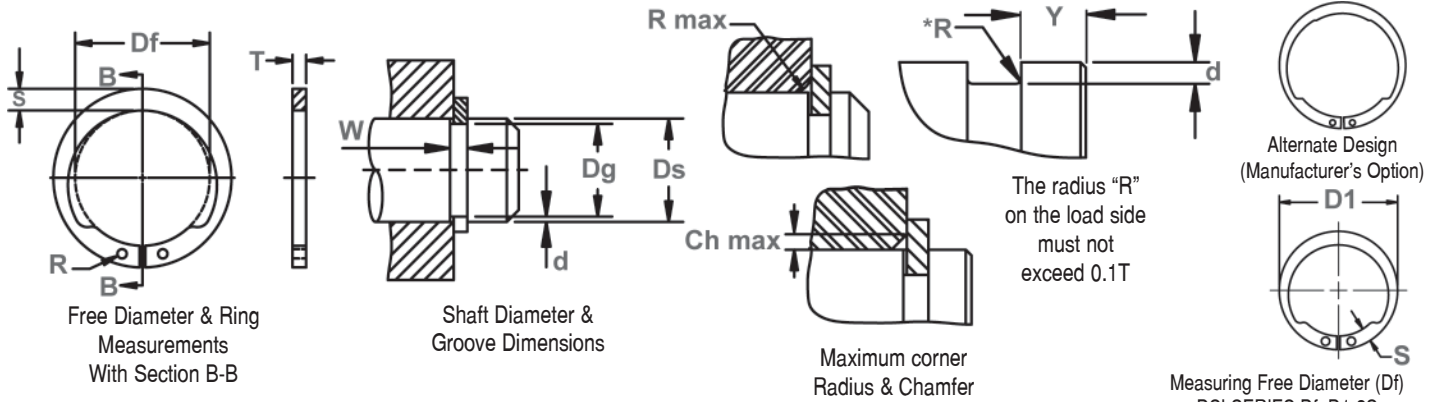

RING NO.	SHAFT DIA.	GROOVE SIZE					RING SIZE & WEIGHT						SUPPLEMENTARY DATA						
		DIAMETER		WIDTH	DEPTH	THICKNESS ***	FREE DIAMETER		MAX. SEC.	HOLE DIA.	WEIGHT	EDGE MARGIN	THRUST LOAD Ring	THRUST LOAD Groove	Allowable Rad/Cham.	Max. load w/R/Ch. Max.	RPM Limits		
		Ds	Dg	Tol.	W Min.	d	T	Tol.	Df	Tol.	S	Tol.	R Min.	kg/1000	Y Min.	Pr kN	Pg kN	R/Ch Max.	P'r kN
DSI-12	12	11.5		1.10	0.25	1.00		11.00		2.1		1.3	0.50	0.7	4.5	0.70	1.0	2.4	79000
DSI-13	13	12.4		1.10	0.30	1.00		11.90		2.1		1.3	0.56	0.9	5.5	0.90	1.0	2.4	64000
DSI-14	14	13.4		1.10	0.30	1.00		12.90	+0.10	2.1		1.3	0.58	0.9	6.0	0.97	1.0	2.4	56000
DSI-15	15	14.3	-0.11	1.10	0.35	1.00		13.80	-0.36	2.2		1.3	0.66	1.0	6.5	1.22	1.0	2.4	50000
DSI-16	16	15.2		1.10	0.40	1.00		14.70		2.3		1.3	0.72	1.2	7.0	1.48	1.0	2.5	45000
DSI-17	17	16.2		1.10	0.40	1.00		15.70		2.4		1.3	0.81	1.2	8.1	1.57	1.0	2.6	41000
DSI-18	18	17.0		1.30	0.50	1.20		16.50		2.6		1.5	1.14	1.5	14.8	2.07	1.5	3.2	39000
DSI-20	20	19.0		1.30	0.50	1.20		18.50		2.8		1.5	1.43	1.5	14.6	2.30	1.5	3.1	32000
DSI-21	21	20.0	-0.15	1.30	0.50	1.20		19.35	+0.13	2.8		1.5	1.53	1.5	14.4	2.42	1.5	3.1	29000
DSI-22	22	21.0		1.30	0.50	1.20	-0.06	20.50	-0.42	3.0		1.5	1.63	1.5	14.2	2.53	1.5	3.1	27000
DSI-23	23	22.0		1.30	0.50	1.20		21.50		3.1	±0.1	1.5	1.78	1.5	14.0	2.66	1.5	3.1	25000
DSI-24	24	22.9		1.30	0.55	1.20		22.20		3.2		1.5	1.90	1.6	14.0	3.03	1.5	3.1	27000
DSI-25	25	23.9		1.30	0.55	1.20		23.20		3.4		1.5	2.10	1.6	14.1	3.18	1.5	3.2	25000
DSI-26	26	24.9	-0.21	1.30	0.55	1.20		24.20	+0.21	3.5		1.5	2.18	1.6	14.1	3.30	1.5	3.2	25000
DSI-28	28	26.6		1.60	0.70	1.50		25.90	-0.42	3.8		2.0	3.18	2.1	28.0	4.50	1.5	6.4	22000
DSI-30	30	28.6		1.60	0.70	1.50		27.90		3.9		2.0	3.58	2.1	27.5	4.86	1.5	6.3	19000
DSI-32	32	30.3		1.60	0.85	1.50		29.60		4.0		2.0	3.88	2.5	27.0	6.25	2.0	4.7	17000
DSI-34	34	32.3	-0.25	1.60	0.85	1.50		31.50	+0.25	3.5		2.0	3.60	2.5	26.6	6.67	2.0	4.6	15000
DSI-35	35	33.0		1.60	1.00	1.50		32.20	-0.50	4.2		2.0	4.53	3.0	26.6	8.00	2.0	4.6	16000
DSI-38	38	35.8		1.85	1.10	1.75		34.50		4.5		2.0	5.50	3.3	42.0	10.60	2.0	7.8	15000

\*\*\* FOR PLATED RINGS, ADD 0.05 TO THE LISTED MAXIMUM THICKNESS. MAXIMUM RING THICKNESS WILL BE A MINIMUM OF 0.005 LESS THAN THE LISTED GROOVE WIDTH (W) MINIMUM.

ALL DIMENSIONS IN MILLIMETERS.



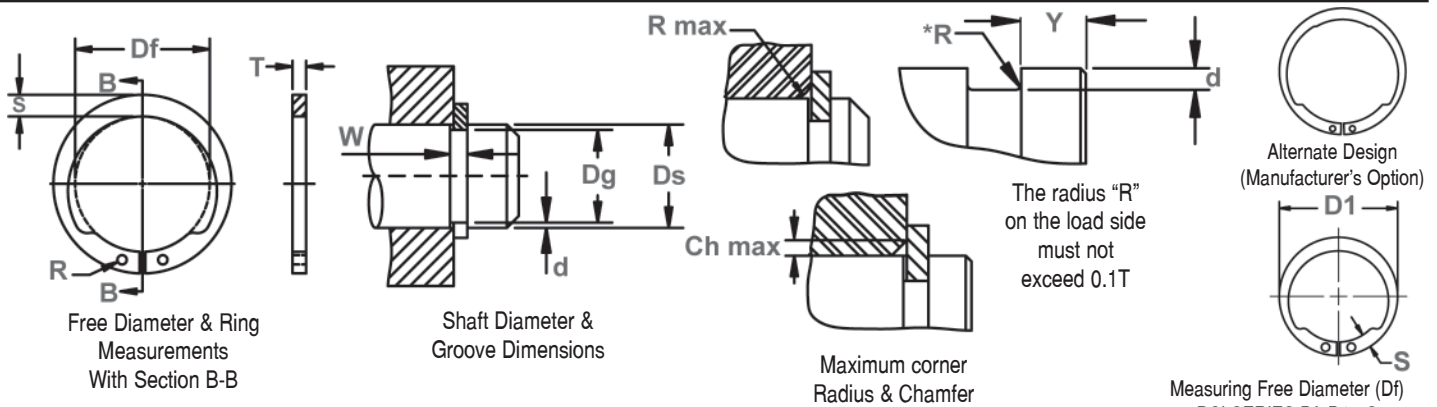

Measuring Free Diameter (Df)  
DSI SERIES Df=D1-2S

RING NO.	SHAFT DIA.	GROOVE SIZE					RING SIZE & WEIGHT						SUPPLEMENTARY DATA						
		DIAMETER		WIDTH	DEPTH	THICKNESS ***	FREE DIAMETER		MAX. SEC.	HOLE DIA.	WEIGHT	EDGE MARGIN	THRUST LOAD Ring	THRUST LOAD Groove	Allowable Rad/Cham.	Max. load w/R/Ch. Max.	RPM Limits		
		Ds	Dg	Tol.	W Min.	d	T	Tol.	Df	Tol.	S	Tol.	R Min.	kg/1000	Y Min.	Pr kN	Pg kN	R/Ch Max.	P'r kN
DSI-40	40	37.5		1.85	1.25	1.75		36.50		4.7		2.0	6.49	3.8	42.0	12.60	2.0	7.8	15000
DSI-42	42	39.5		1.85	1.25	1.75		38.50		4.7		2.0	6.51	3.8	42.0	13.30	2.0	7.8	13000
DSI-45	45	42.5	-0,25	1.85	1.25	1.75	-0,06	41.50	+0,39	4.7		2.0	7.80	3.8	41.5	14.30	2.0	7.8	11000
DSI-47	47	44.5		1.85	1.25	1.75		43.50	-0,90	5.0		2.0	8.09	3.8	41.0	15.00	2.0	7.8	10000
DSI-48	48	45.5		1.85	1.25	1.75		44.50		5.2	±0,2	2.0	8.48	3.8	41.0	15.80	2.0	7.8	10000
DSI-50	50	47.0		2.15	1.50	2.00		45.80		5.2		2.5	9.84	4.5	58.0	19.20	2.0	11,6	10000
DSI-55	55	52.0		2.15	1.50	2.00		50.80		5.8		2.5	11.42	4.5	58.0	21.00	2.5	9,3	9000
DSI-58	58	55.0		2.15	1.50	2.00		53.80		5.8		2.5	13.00	4.5	56.0	22.20	2.5	9,2	8000
DSI-60	60	57.0		2.15	1.50	2.00		55.80		5.8		2.5	13.80	4.5	55.5	23.00	2.5	9,1	7000
DSI-65	65	62.0	-0,30	2.65	1.50	2.50	-0,07	60.80		6.0		2.5	20.75	4.5	104.0	24.80	2.5	17,6	6000
DSI-70	70	67.0		2.65	1.50	2.50		65.50	+0,46	6.5		2.5	23.70	4.5	103.0	27.00	2.5	17,6	6000
DSI-72	72	69.0		2.65	1.50	2.50		67.50	-1,10	6.5		2.5	24.70	4.5	104.0	27.70	2.5	18,0	6000
DSI-75	75	72.0		2.65	1.50	2.50		70.50		6.5		2.5	27.50	4.5	100.0	29.20	2.5	17,7	5000
DSI-80	80	76.5		2.65	1.75	2.50		74.50		7.0		2.5	28.90	5.3	96.0	36.60	3.0	14,6	6000
DSI-82	82	78.5		2.65	1.75	2.50		76.50		7.0	±0,3	2.5	29.65	5.3	100.0	37.40	3.0	15,4	5000
DSI-85	85	81.5		3.15	1.75	3.00		79.50		7.4		3.0	39.50	5.3	167.0	38.30	3.0	25,6	5000
DSI-87	87	83.5	-0,35	3.15	1.75	3.00		81.50		7.4		3.0	40.00	5.3	164.0	39.20	3.0	25,5	5000
DSI-90	90	86.5		3.15	1.75	3.00	-0,08	84.50	+0,54	7.4		3.0	41.92	5.3	157.0	41.70	3.0	24,8	4000
DSI-95	95	91.5		3.15	1.75	3.00		89.50	-1,30	8.0		3.0	47.70	5.3	152.0	42.70	3.5	21,0	4000
DSI-100	100	96.5		3.15	1.75	3.00		94.50		8.0		3.0	49.92	5.3	144.0	45.80	3.5	20,5	4000

\*\*\* FOR PLATED RINGS, ADD 0.05 TO THE LISTED MAXIMUM THICKNESS. MAXIMUM RING THICKNESS WILL BE A MINIMUM OF 0.005 LESS THAN THE LISTED GROOVE WIDTH (W) MINIMUM.

ALL DIMENSIONS IN MILLIMETERS.

HARDNESS RANGES: STAINLESS STEEL RINGS (DIN 1.4122 X39CrMo17)

RING TYPE	SIZE RANGE	HARDNESS			
		HV	HRC	15N	30N
DSI	ALL	470-580	47-54	84-87.5	66-72

HARDNESS RANGES: CARBON STEEL RINGS (SAE 1060-1090)

RING TYPE	SIZE RANGE	HARDNESS		
		VICKERS	ROCKWELL	
			HRC	LOWER SCALE*
DSI	12-17	470-580	47-54	66-72 HR30N
	18-48	470-580	47-54	-
	50-100	435-530	44-51	-

\*WHERE APPLICABLE



# DST Shaft Rings

(DIN 983)

## Axially Assembled, External Teeth, Metric

Similar in design to the DSH external ring, this features several "teeth" equally distributed along the circumference of the ring. The increased shoulder offered by the teeth is particularly effective in retaining applications with large radii or chamfers.

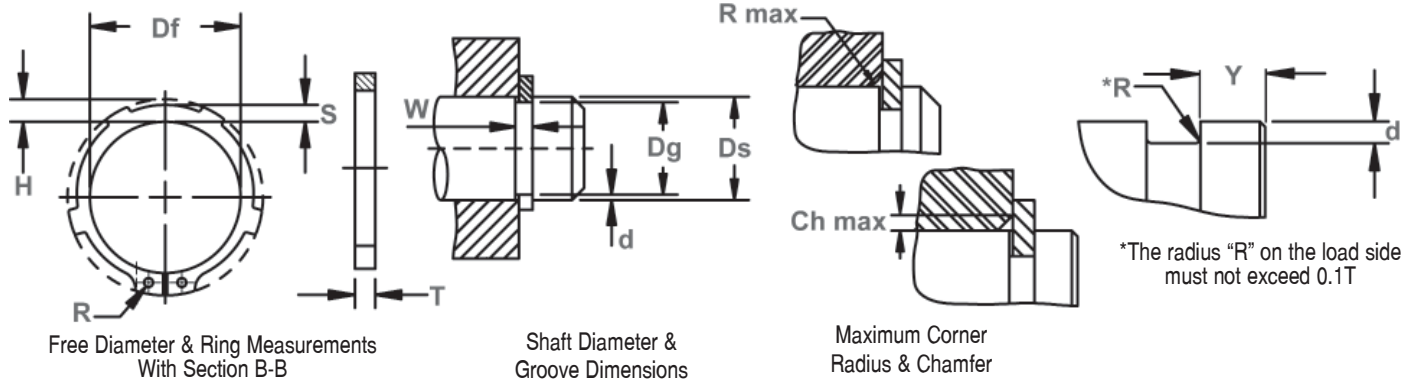

\*The radius "R" on the load side must not exceed 0.1T

RING NO.	SHAFT DIA.	GROOVE SIZE				RING SIZE & WEIGHT								SUPPLEMENTARY DATA					
		DIAMETER		WIDTH	DEPTH	THICKNESS ***		FREE DIAMETER		LUG HT.	MAX. SEC.	HOLE DIA.	WEIGHT	EDGE MARGIN	THRUST LOAD Ring	THRUST LOAD Groove	Allowable Rad/Cham.	Max. load w/ R/Ch. Max.	RPM Limits
		Ds	Dg	Tol.	W	d	T	Tol.	Df	Tol.	H Max.	S	R Min.	kg/1000	Y	Pr kN	Pg kN	R/Ch Max.	P'r kN
DST-16	16	15,2		1,10	0,40	1,00		14,7		3,5	2,3	1,7	0,82	1,2	7,4	3,26	1,0	2,4	45000
DST-17	17	16,2	-0,11	1,10	0,40	1,00		15,7	+0,10	3,6	2,4	1,7	0,93	1,2	8,0	3,46	1,0	2,4	41000
DST-18	18	17,0		1,30	0,50	1,20		16,5	-0,36	3,7	2,5	2,0	1,24	1,5	17,0	4,58	1,5	3,7	38000
DST-19	19	18,0		1,30	0,50	1,20		17,5		3,7	2,6	2,0	1,35	1,5	17,0	4,85	1,5	3,8	33000
DST-20	20	19,0		1,30	0,50	1,20		18,5		3,8	2,6	2,0	1,45	1,5	17,1	5,06	1,5	3,8	30000
DST-22	22	21,0	-0,15	1,30	0,50	1,20		20,5	+0,13	4,0	2,8	2,0	1,77	1,5	16,9	5,65	1,5	3,8	26000
DST-23	23	22,0		1,30	0,50	1,20		21,5	-0,42	4,1	2,9	2,0	1,84	1,5	16,6	5,90	1,5	3,8	24000
DST-24	24	22,9		1,30	0,55	1,20		22,2		4,2	3,0	2,0	1,98	1,6	16,1	6,75	1,5	3,6	26000
DST-25	25	23,9		1,30	0,55	1,20		23,2		4,3	3,0	2,0	2,12	1,6	16,2	7,05	1,5	3,7	24000
DST-26	26	24,9	-0,21	1,30	0,55	1,20		24,2		4,4	3,1	2,0	2,18	1,6	16,1	7,34	1,5	3,7	22000
DST-28	28	26,6		1,60	0,70	1,50	-0,06	25,9	+0,21	4,5	3,3	2,0	3,15	2,1	32,1	10,00	1,5	7,5	20000
DST-29	29	27,6		1,60	0,70	1,50		26,9	-0,42	4,7	3,4	2,0	3,35	2,1	31,8	10,30	1,5	7,4	19000
DST-30	30	28,6		1,60	0,70	1,50		27,9		4,7	3,4	2,0	3,65	2,1	32,1	10,70	1,5	7,6	18000
DST-32	32	30,3		1,60	0,85	1,50		29,6		5,0	3,6	2,5	4,00	2,5	31,2	13,80	2,0	5,5	16000
DST-34	34	32,3		1,60	0,85	1,50		31,5		5,1	3,8	2,5	4,15	2,5	31,3	14,70	2,0	5,6	16000
DST-35	35	33,0		1,60	1,00	1,50		32,2	+0,25	5,2	3,8	2,5	4,38	3,0	30,8	17,80	2,0	5,5	15000
DST-37	37	35,0		1,85	1,00	1,75		34,2	-0,50	5,4	4,0	2,5	6,30	3,0	50,0	18,80	2,0	9,1	13000
DST-38	38	36,0	-0,25	1,85	1,00	1,75		35,2		5,5	4,1	2,5	6,50	3,0	49,5	19,30	2,0	9,1	13000
DST-40	40	37,5		1,85	1,25	1,75		36,5		7,2	4,2	2,5	7,00	3,8	51,0	25,30	2,0	9,5	14000
DST-42	42	39,5		1,85	1,25	1,75		38,5	+0,39	7,2	4,5	2,5	7,50	3,8	50,0	26,70	2,0	9,4	13000
DST-45	45	42,5		1,85	1,25	1,75		41,5	-0,90	7,2	4,6	2,5	8,50	3,8	49,0	28,60	2,0	9,3	11000
DST-47	47	44,5		1,85	1,25	1,75		43,5		7,2	4,8	2,5	8,70	3,8	49,5	30,00	2,0	9,5	10000

\*\*\* FOR PLATED RINGS, ADD 0.05 TO THE LISTED MAXIMUM THICKNESS. MAXIMUM RING THICKNESS WILL BE A MINIMUM OF 0.005 LESS THAN THE LISTED GROOVE WIDTH (W) MINIMUM.

ALL DIMENSIONS IN MILLIMETERS.

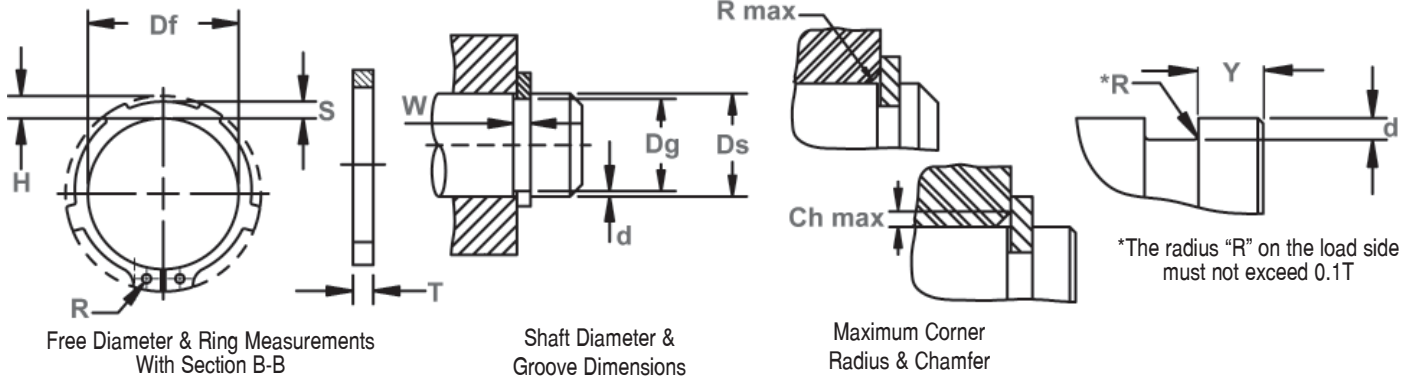

RING NO.	SHAFT DIA.	GROOVE SIZE						RING SIZE & WEIGHT						SUPPLEMENTARY DATA						
		DIAMETER		WIDTH	DEPTH		THICKNESS ***		FREE DIAMETER		LUG HT.	MAX. SEC.	HOLE DIA.	WEIGHT	EDGE MARGIN	THRUST LOAD Ring	THRUST LOAD Groove	Allowable Rad/ Cham.	Max. load w/ R/Ch. Max.	RPM Limits
		Ds	Dg	Tol.	W	d	T	Tol.	Df	Tol.	H Max.	S	R Min.	kg/ 1000	Y	Pr kN	Pg kN	R/Ch Max.	P'r kN	
DST-48	48	45.5	-0.25	1.85	1.25	1.75	-0.06	44.5	+0.39	7.2	4.9	2.5	8.90	3.8	49.4	30.70	2.0	9.5	9000	
DST-50	50	47.0		2.15	1.50	2.00		45.8	-0.90	8.2	5.0	2.5	11.50	4.5	73.3	38.00	2.0	14.4	10000	
DST-55	55	52.0		2.15	1.50	2.00		50.8		8.2	5.4	2.5	12.99	4.5	71.4	42.00	2.5	11.4	8000	
DST-57	57	54.0		2.15	1.50	2.00		52.8		8.2	5.6	2.5	14.00	4.5	70.9	43.70	2.5	11.4	8000	
DST-58	58	55.0		2.15	1.50	2.00		53.8		8.2	5.7	2.5	14.30	4.5	71.1	44.30	2.5	11.5	8000	
DST-60	60	57.0		2.15	1.50	2.00		55.8		8.2	5.8	2.5	14.80	4.5	69.3	46.00	2.5	11.3	7000	
DST-62	62	59.0		2.15	1.50	2.00	-0.07	57.8		8.2	5.9	2.5	15.90	4.5	69.3	47.50	2.5	11.4	7000	
DST-65	65	62.0	-0.30	2.65	1.50	2.50		60.8	+0.46	10.2	6.2	3.0	21.70	4.5	135.0	49.80	2.5	22.7	6000	
DST-67	67	64.0		2.65	1.50	2.50		62.5	-1.10	10.2	6.4	3.0	22.60	4.5	136.0	51.30	2.5	23.0	7000	
DST-68	68	65.0		2.65	1.50	2.50		63.5		10.2	6.5	3.0	23.50	4.5	135.0	52.20	2.5	23.0	7000	
DST-70	70	67.0		2.65	1.50	2.50		65.5		10.2	6.6	3.0	25.10	4.5	134.0	53.80	2.5	23.0	6000	
DST-75	75	72.0		2.65	1.50	2.50		70.5		10.2	7.0	3.0	28.20	4.5	130.0	57.60	2.5	22.8	6000	
DST-80	80	76.5		2.65	1.75	2.50		74.5		10.2	7.4	3.0	30.75	5.3	128.0	71.60	3.0	19.5	6000	
DST-85	85	81.5		3.15	1.75	3.00		79.5		10.2	7.8	3.5	39.50	5.3	215.0	76.20	3.0	33.4	5000	
DST-90	90	86.5	-0.35	3.15	1.75	3.00	-0.08	84.5		10.2	8.2	3.5	47.70	5.3	217.0	80.20	3.0	33.4	5000	
DST-95	95	91.5		3.15	1.75	3.00		89.5		10.2	8.6	3.5	53.00	5.3	212.0	85.50	3.5	29.3	4000	
DST-100	100	96.5		3.15	1.75	3.00		94.5	+0.54	10.2	9.0	3.5	56.60	5.3	206.0	90.00	3.5	29.0	4000	
DST-110	110	106.0	-0.54	4.15	2.00	4.00	-0.10	103.0	-1.30	12.2	9.6	3.5	84.60	6.0	457.0	113.00	3.5	66.9	4000	
DST-120	120	116.0		4.15	2.00	4.00		113.0		14.2	10.1	3.5	89.70	6.0	424.0	123.00	3.5	64.5	4000	
DST-130	130	126.0	-0.63	4.15	2.00	4.00		123.0		14.2	10.7	4.0	105.00	6.0	395.0	134.00	4.0	55.2	3000	
DST-140	140	136.0		4.15	2.00	4.00		133.0		14.2	11.2	4.0	115.00	6.0	376.0	144.00	4.0	54.4	3000	

\*\*\* FOR PLATED RINGS, ADD 0.05 TO THE LISTED MAXIMUM THICKNESS. MAXIMUM RING THICKNESS WILL BE A MINIMUM OF 0.005 LESS THAN THE LISTED GROOVE WIDTH (W) MINIMUM.

ALL DIMENSIONS IN MILLIMETERS.

NUMBER OF TEETH (INCLUDING LUGS)

RING TYPE	SIZE RANGE	# TEETH
DST	16-58	6
	60-140	8

HARDNESS RANGES: CARBON STEEL RINGS (SAE 1060-1090)

RING TYPE	SIZE RANGE	HARDNESS		
		VICKERS	ROCKWELL	
			HRC	LOWER SCALE*
DST	16 & 17	470-580	47-54	66-72 HR30N
	18-48	470-580	47-54	-
	50-140	435-530	44-51	-

\*WHERE APPLICABLE

HARDNESS RANGES: STAINLESS STEEL RINGS (DIN 1.4122 X39CrMo17)

RING TYPE	SIZE RANGE	HARDNESS			
		HV	HRC	15N	30N
DST	ALL	470-580	47-54	84-87.5	66-72





# DE Shaft Rings

(DIN 6799)\*\*

## Radially Assembled, External E, Metric

Perhaps the most popular and widely used radial retaining ring is the "E" (so named because it is shaped like the letter "E").

Three prongs make contact with the bottom of the groove and provide a shoulder for effective retention of assemblies.

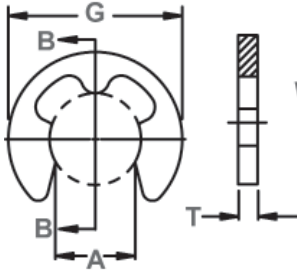

Ring Measurements

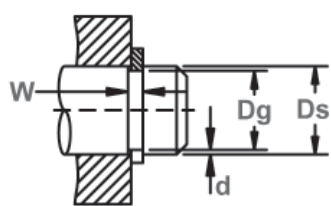

Shaft Diameter & Groove Dimensions

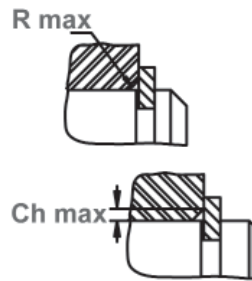

Maximum Corner Radius & Chamfer

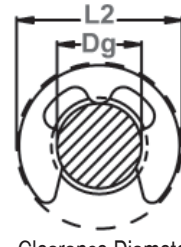

Clearance Diameter Installed In Groove

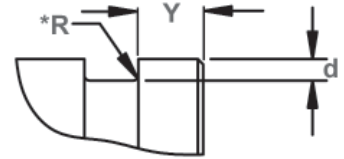

Edge Margin (Y)  
The radius "R" on the load side must not exceed 0.1T.

RING NO.	NOM SIZE	SHAFT DIA. (mm)			GROOVE SIZE				RING SIZE & WEIGHT				CLEARANCE			SUPPLEMENTARY DATA					
					DIAMETER		WIDTH		THICKNESS ***		GAP		FREE O.D.	IN-STALLED IN GROOVE	EDGE MARGIN	Thrust Load Ring*	THRUST LOAD Groove		Allowable Rad/Cham	Max. load w/R/Ch Max.	RPM Limits
					Dg	From	To	Dg	Tol.	W	Tol.	T	Tol.	A	Tol.	kg/1000	G Ref.	L2 Max.	Y Min.	Pr kN	Pg kN
DE-0.8	0.8	1.0	1.4	0.8	-0.04	0.24	+0.04	0.2		0.58		0.003	1.95	2.25	0.4	0.08	0.03	1.2	0.3	0.04	50000
DE-1.2	1.2	1.4	2.0	1.2		0.34	-0.00	0.3		1.01		0.009	2.90	3.25	0.6	0.12	0.04	1.5	0.4	0.06	47000
DE-1.5	1.5	2.0	2.5	1.5	-0.06	0.44		0.4		1.28	±0.04	0.021	3.90	4.25	0.8	0.22	0.07	2.0	0.6	0.11	42000
DE-1.9	1.9	2.5	3.0	1.9		0.54		0.5		1.61		0.040	4.40	4.8	1.0	0.35	0.10	2.5	0.7	0.17	40000
DE-2.3	2.3	3.0	4.0	2.3		0.64		0.6		1.94		0.069	5.90	6.3	1.0	0.50	0.15	3.0	0.9	0.24	38000
DE-3.2	3.2	4.0	5.0	3.2		0.64		0.6	±0.02	2.70		0.088	6.90	7.3	1.0	0.65	0.22	4.0	0.9	0.32	35000
DE-4	4.0	5.0	7.0	4.0	-0.075	0.74	+0.05	0.7		3.34		0.158	8.85	9.3	1.2	0.95	0.25	5.0	1.0	0.47	32000
DE-5	5.0	6.0	8.0	5.0		0.74	-0.00	0.7		4.11	±0.048	0.236	10.85	11.3	1.2	1.15	0.90	7.0	1.0	0.60	28000
DE-6	6.0	7.0	9.0	6.0		0.74		0.7		5.26		0.255	11.80	12.3	1.2	1.35	1.10	8.0	1.1	0.70	25000
DE-7	7.0	8.0	11.0	7.0		0.94		0.9		5.84		0.474	13.80	14.3	1.5	1.80	1.25	9.0	1.3	1.00	22000
DE-8	8.0	9.0	12.0	8.0	-0.09	1.05		1.0		6.52		0.660	15.75	16.3	1.8	2.50	1.42	10.0	1.5	1.25	20000
DE-9	9.0	10.0	14.0	9.0		1.15		1.1		7.63	±0.058	1.090	18.20	18.8	2.0	3.00	1.60	11.0	1.6	1.50	17000
DE-10	10.0	11.0	15.0	10.0		1.25		1.2		8.32		1.250	19.70	20.4	2.0	3.50	1.70	12.0	1.8	1.75	15000
DE-12	12.0	13.0	18.0	12.0	-0.11	1.35	+0.08	1.3	±0.03	10.45		1.630	22.70	23.4	2.5	4.70	3.10	15.0	1.9	2.30	13000
DE-15	15.0	16.0	24.0	15.0		1.55	-0.00	1.5		12.61	±0.07	3.370	28.70	29.4	3.0	7.80	7.00	20.0	2.2	3.30	11000
DE-19	19.0	20.0	31.0	19.0		1.80		1.75		15.92		6.420	36.50	37.6	3.5	11	10.00	25.0	2.5	3.60	7600
DE-24	24.0	25.0	38.0	24.0	-0.13	2.05		2.00		21.88	±0.084	8.550	43.50	44.6	4.0	15	13.00	30.0	3.0	4.00	5500
DE-30	30.0	32.0	42.0	30.0		2.55		2.50		25.80		13.50	51.30	52.6	4.5	23	16.50	36.0	3.5	5.30	4200

ALL DIMENSIONS IN MILLIMETERS.

\* SHARP CORNER ABUTMENT.

The radius "R" on the load side must not exceed 0.1T.

\*\* DIN6799 only defines rings in carbon steel. Rings in other materials are dimensioned as defined in Rotor Clip specific drawings.

These are available from the Rotor Clip Technical Sales department.

\*\*\* FOR PLATED RINGS, ADD 0.05 TO THE LISTED MAXIMUM THICKNESS. MAXIMUM RING THICKNESS WILL BE A MINIMUM OF 0.005 LESS THAN THE LISTED GROOVE WIDTH (W) MINIMUM.

HARDNESS RANGES: STAINLESS STEEL RINGS (PH 15-7MO)

RING TYPE	SIZE RANGE	HARDNESS		
		VICKERS	ROCKWELL	
			HRC	LOWER SCALE*
DE	0.8-1.5	435-530	44-51	82.5-86 HR15N**
	1.9	435-530	44-51	82.5-86 HR15N
	2.3-9	435-530	44-51	63-69.5 HR30N
	10-30	435-530	44-51	-

\*WHERE APPLICABLE

\*\*HARDNESS CAN NOT BE CHECKED WITH ANY DEGREE OF ACCURACY DIRECTLY ON THESE RINGS.

HARDNESS RANGES: STAINLESS STEEL RINGS (DIN 1.4122 X39CrMo17)

RING TYPE	SIZE RANGE	HARDNESS			
		HV	HRC	15N	
				30N	
DE	ALL	470-580	47-54	84-87.5	66-72

HARDNESS RANGES: BERYLLIUM COPPER RINGS

RING TYPE	SIZE RANGE	HARDNESS		
		VICKERS	ROCKWELL	
			HRC	LOWER SCALE*
DE	0.8-1.5	360-415	37-43	79-82 HR15N**
	1.9	360-415	37-43	79-82 HR15N
	2.3-9	360-415	37-43	56.5-62 HR30N
	10-30	360-415	37-43	-

\*WHERE APPLICABLE

\*\*HARDNESS CAN NOT BE CHECKED WITH ANY DEGREE OF ACCURACY DIRECTLY ON THESE RINGS.

HARDNESS RANGES: CARBON STEEL RINGS (SAE 1060-1090)

RING TYPE	SIZE RANGE	HARDNESS		
		VICKERS	ROCKWELL	
			HRC	LOWER SCALE*
DE	0.8-1.5	460-580	46-54	83.5-87.5 HR15N**
	1.9	460-580	46-54	83.5-87.5 HR15N
	2.3-9	460-580	46-54	65-72 HR30N
	10-30	460-580	46-54	-

\*WHERE APPLICABLE

\*\*HARDNESS CAN NOT BE CHECKED WITH ANY DEGREE OF ACCURACY DIRECTLY ON THESE RINGS.





# External, Self-Locking Friction, Metric

The DSF ring resembles a regular DSH ring except that it is designed to function on a shaft without a groove. The design of the ring causes it to exert significant gripping power uniformly on the shaft (except where the gap occurs.)

# DSF Shaft Rings

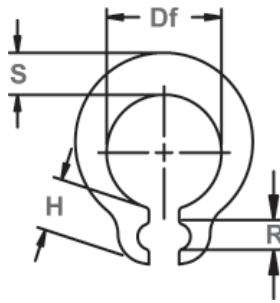

Free Diameter & Ring Measurements

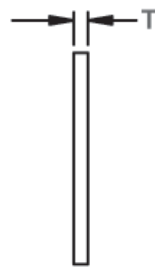

Shaft Diameter

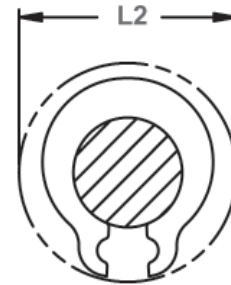
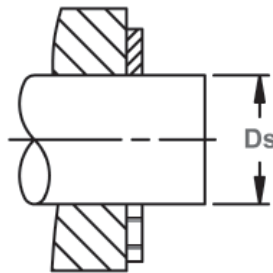

Clearance Diameter Installed on Shaft

RING NO.	SHAFT DIA. (mm)	RING SIZE & WEIGHT							SUPPLEMENTARY DATA		
		FREE DIAMETER		THICKNESS	LUG HEIGHT	MAX. SECTION	NOTCH	WEIGHT	CLEARANCE Released Over Shaft	THRUST LOAD	RPM Limits
		Ds	Df	Tol.	T	H Max.	S Ref.	R Min.	kg/1000	L2	
DSF-1,5	1,5	1,40	±0,02	0,4	1,7	0,7	0,9	0,013	5,1	40	350000
DSF-2	2	1,90		0,6	1,9	1,0	0,9	0,036	6,0	50	260000
DSF-2,2	2,2	2,05	±0,025	0,6	1,9	1,1	0,9	0,038	6,2	50	270000
DSF-2,5	2,5	2,35	±0,030	0,6	1,9	1,2	0,9	0,045	6,5	60	220000
DSF-2,8	2,8	2,65	±0,035	0,6	2,0	1,3	0,9	0,057	7,0	70	190000
DSF-3	3	2,85	±0,04	0,6	2,1	1,4	0,9	0,065	7,4	75	170000
DSF-3,5	3,5	3,30	±0,05	0,6	2,3	1,6	0,9	0,081	8,3	90	150000
DSF-4	4	3,80	±0,06	0,8	2,7	1,8	1,2	0,154	9,6	100	125000
DSF-4,5	4,5	4,25		0,8	2,9	2,0	1,3	0,173	10,5	120	120000
DSF-5	5	4,75	±0,075	0,8	2,9	2,2	1,3	0,200	11,0	130	100000
DSF-5,5	5,5	5,20		0,8	3,0	2,2	1,3	0,216	11,7	150	90000
DSF-6	6	5,70		1,00	3,2	2,4	1,4	0,402	12,6	170	81000
DSF-7	7	6,70	±0,09	1,00	3,4	2,7	1,4	0,428	14,0	180	63000
DSF-8	8	7,70		1,00	3,5	3,0	1,4	0,524	15,2	200	52000
DSF-9	9	8,65		1,20	4,7	3,3	2,0	0,808	18,6	230	46000
DSF-10	10	9,65	±0,11	1,20	4,7	3,5	2,0	0,944	19,6	250	39000
DSF-10,5	10,5	10,20		1,20	4,0	3,8	1,5	1,100	18,7	260	34000
DSF-11	11	10,60		1,20	4,8	4,2	2,0	1,208	20,8	280	37000
DSF-12	12	11,60		1,20	4,8	4,6	2,0	1,454	21,8	300	33000
DSF-13	13	12,55		1,20	5,3	5,0	2,0	1,750	23,8	320	31000
DSF-13,8	13,8	13,30		1,50	5,1	5,4	2,2	2,492	24,8	350	30000
DSF-14	14	13,50		1,50	5,1	5,4	2,2	2,456	25,0	350	29000
DSF-15	15	14,50		1,50	5,1	5,6	2,2	2,716	26,4	400	26000
DSF-16	16	15,40		1,50	5,6	5,8	2,5	2,940	27,8	500	26000
DSF-17	17	16,35		1,75	6,0	6,2	2,5	4,010	29,5	600	24000
DSF-18	18	17,30	1,75	6,1	6,6	2,5	4,460	31,4	700	23000	
DSF-20	20	19,30	±0,13	1,75	6,1	7,1	2,5	5,270	34,4	700	20000
DSF-22	22	21,20		1,75	6,6	7,4	2,5	6,060	37,0	750	18000
DSF-24	24	23,15		1,75	6,6	7,8	2,5	7,000	39,8	750	16000
DSF-25	25	24,15		1,75	6,6	8,2	2,5	7,450	41,6	750	15000
DSF-30	30	29,00		1,75	9,0	9,0	2,5	10,000	48,2	750	12000

ALL DIMENSIONS IN MILLIMETERS.

HARDNESS RANGES: STAINLESS STEEL RINGS (DIN 1.4122 X39CrMo17)

RING TYPE	SIZE RANGE	HARDNESS			
		HV	HRC	15N	30N
DSF	ALL	470-580	47-54	84-87.5	66-72

HARDNESS RANGES: CARBON STEEL RINGS (SAE 1060-1090)

RING TYPE	SIZE RANGE	HARDNESS		
		VICKERS	ROCKWELL	
			HRC	LOWER SCALE*
DSF	1.5	485-560	48-53	84.5-87 HR15N**
	2-8	485-560	48-53	66.5-71 HR30N
	9-30	485-560	48-53	-

\*WHERE APPLICABLE

\*\*HARDNESS CAN NOT BE CHECKED WITH ANY DEGREE OF ACCURACY DIRECTLY ON THESE RINGS.



# DC Shaft Rings

## Radially Assembled, External Crescent, Metric

Ideal for low clearance applications where radial installation is preferred.

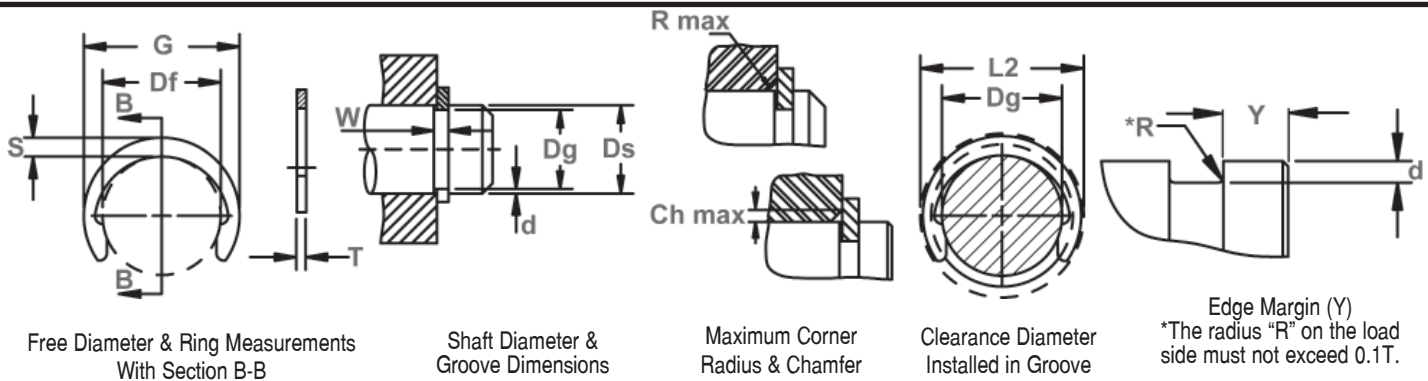

RING NO.	SHAFT DIA. (mm)	GROOVE SIZE			RING SIZE & WEIGHT				CLEARANCE				SUPPLEMENTARY DATA						
		DIAMETER		WIDTH	DEPTH	THICKNESS ***		FREE DIAMETER		MAX. SEC.	WGHT.	FREE O.D.	INSTALLED IN GROOVE	EDGE MARGIN	THRUST LOAD Ring	THRUST LOAD Groove	Allowable Rad/Cham	Max Load w/ R/Ch Max	RPM Limits
		Ds	Dg	Tol.	W Min.	d Ref.	T	Tol.	Df	Tol.	S max ref.	kg/1000	G Ref.	L2 Max.	Y Min.	Pr kN	Pg kN	R/Ch Max.	P'r kN
DC-3	3	2,3		0,44	0,35	0,40		2,18	±0,06	0,90	0,02	3,98	4,1	1,0	0,50	0,24	0,40	0,40	95000
DC-4	4	3,2	-0,07	0,44	0,40	0,40		3,00		1,00	0,04	5,00	5,2	1,2	0,50	0,37	0,40	0,40	90000
DC-5	5	4,0		0,64	0,50	0,60	-0,05	3,80		1,20	0,08	6,20	6,4	1,5	1,10	0,58	0,60	0,70	88000
DC-6	6	5,0		0,74	0,50	0,70		4,80	±0,08	1,30	0,11	7,40	7,6	1,5	1,65	0,72	0,70	1,10	80000
DC-7	7	6,0		0,85	0,50	0,80		5,80		1,40	0,13	8,60	8,8	1,5	2,20	0,85	0,80	1,30	69000
DC-8	8	7,0	-0,09	0,85	0,50	0,80		6,80		1,60	0,17	10,00	10,2	1,5	2,20	0,98	0,80	1,30	67000
DC-9	9	8,0		1,10	0,50	1,00		7,80	±0,09	1,70	0,22	11,20	11,4	1,5	3,50	1,10	1,00	2,00	58000
DC-10	10	9,0		1,10	0,50	1,00		8,75		1,70	0,26	12,15	12,4	1,5	3,70	1,24	1,00	2,00	50000
DC-11	11	10,0		1,10	0,50	1,00		9,65		1,80	0,29	13,20	13,6	1,5	4,00	1,35	1,00	2,00	40000
DC-12	12	10,9		1,10	0,55	1,00		10,55		1,90	0,32	14,35	14,7	1,7	4,20	1,65	1,00	2,00	35000
DC-13	13	11,8		1,10	0,60	1,00		11,40		2,00	0,36	15,40	15,8	1,8	4,50	1,90	1,00	2,00	30000
DC-14	14	12,7		1,10	0,65	1,00	-0,06	12,30		2,00	0,40	16,30	16,7	2,0	5,00	2,20	1,00	2,00	27000
DC-15	15	13,6	-0,11	1,10	0,70	1,00		13,20	±0,18	2,10	0,46	17,40	17,8	2,1	5,50	2,60	1,00	2,00	25000
DC-16	16	14,5		1,10	0,75	1,00		14,10		2,20	0,54	18,50	18,9	2,3	5,80	3,00	1,00	2,00	24000
DC-17	17	15,4		1,10	0,80	1,00		14,90		2,25	0,64	19,40	19,9	2,4	6,00	3,40	1,00	2,00	23000
DC-18	18	16,3		1,30	0,85	1,20		15,80		2,30	0,72	20,40	20,9	2,6	8,50	3,70	1,20	2,80	21000
DC-19	19	17,2		1,30	0,90	1,20		16,70		2,40	0,80	21,50	22,0	2,7	9,00	4,30	1,20	2,80	21000
DC-20	20	18,1	-0,21	1,30	0,95	1,20		17,55		2,55	0,87	22,65	23,2	2,9	9,40	4,70	1,20	3,00	20000

ALL DIMENSIONS IN MILLIMETERS.

\*The radius "R" on the load side must not exceed 0.1 T

\*\*\* FOR PLATED RINGS, ADD 0.05 TO THE LISTED MAXIMUM THICKNESS. MAXIMUM RING THICKNESS WILL BE A MINIMUM OF 0.005 LESS THAN THE LISTED GROOVE WIDTH (W) MIN.

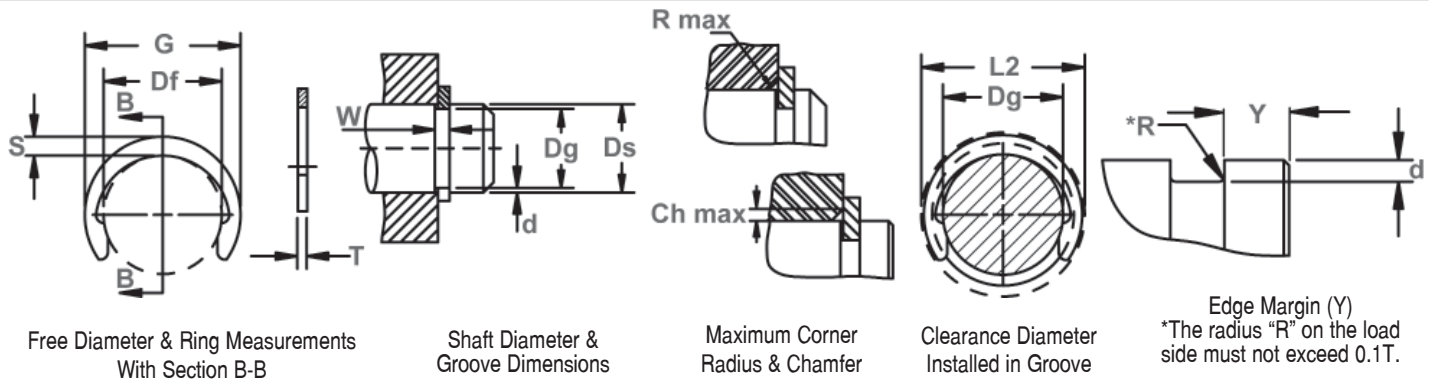

Edge Margin (Y)  
\*The radius "R" on the load side must not exceed 0.1T.

RING NO.	SHAFT DIA. (mm)	GROOVE SIZE			RING SIZE & WEIGHT				CLEARANCE				SUPPLEMENTARY DATA							
		D <sub>s</sub>	D <sub>g</sub>	Tol.	W Min.	d Ref.	T	Tol.	D <sub>f</sub>	Tol.	S max ref.	kg/1000	G Ref.	L2 Max.	Y Min.	Pr kN	Pg kN	R/Ch Max.	P'r kN	RPM Limits
DC-22	22	19.9		1.30	1.05	1.20		19.40		2.80	1.10	25.00	25.5	3.2	10.00	5.70	1.20	3.00	17000	
DC-23	23	20.8		1.30	1.10	1.20		20.20		2.90	1.15	26.00	26.6	3.3	10.50	6.20	1.20	3.20	15000	
DC-24	24	21.7		1.30	1.15	1.20		21.10		3.00	1.52	27.10	27.7	3.5	11.00	6.80	1.20	3.20	15000	
DC-25	25	22.6	-0.21	1.30	1.20	1.20		22.00	±0.21	3.15	1.74	28.30	28.9	3.6	11.50	7.50	1.20	3.20	15000	
DC-26	26	23.5		1.30	1.25	1.20		22.90		3.25	1.88	29.40	30.0	3.8	12.00	8.00	1.20	3.20	15000	
DC-28	28	25.2		1.60	1.40	1.50		24.60		3.50	2.32	31.60	32.2	4.2	16.50	9.70	1.50	5.50	13000	
DC-30	30	27.0		1.60	1.50	1.50		26.30		3.70	2.43	33.70	34.4	4.5	17.00	11.00	1.50	5.60	13000	
DC-32	32	28.8		1.60	1.60	1.50	-0.06	28.10		4.00	3.02	36.10	36.8	4.6	18.00	12.50	1.50	5.80	13000	
DC-35	35	31.5		1.60	1.75	1.50		30.80		4.30	3.30	39.40	40.1	5.3	20.00	15.00	1.50	5.80	11000	
DC-36	36	32.4		1.85	1.80	1.75		31.70	±0.25	4.40	4.40	40.50	41.2	5.4	25.00	16.00	1.75	8.30	10000	
DC-38	38	34.2		1.85	1.90	1.75		33.40		4.60	4.62	42.60	43.4	5.7	26.00	17.50	1.75	8.50	10000	
DC-40	40	36.0		1.85	2.00	1.75		35.20		4.90	5.05	45.00	45.8	6.0	27.50	20.00	1.75	8.80	9000	
DC-42	42	37.8	-0.25	1.85	2.10	1.75		37.00		5.10	5.46	47.20	48.0	6.3	28.00	21.50	1.75	8.90	9000	
DC-45	45	40.5		1.85	2.25	1.75		39.60		5.50	5.98	50.60	51.5	6.8	30.00	25.00	1.75	9.00	8000	
DC-48	48	43.2		1.85	2.40	1.75		42.30	±0.39	5.90	7.82	54.10	55.0	7.2	32.00	28.00	1.75	9.00	8000	
DC-50	50	45.0		2.15	2.50	2.00		44.00		6.20	8.85	56.40	57.4	7.5	39.50	31.00	2.00	12.00	7000	
DC-52	52	47.0		2.15	2.50	2.00	-0.07	46.00		6.30	9.33	58.60	59.6	7.5	41.00	32.00	2.00	12.00	7000	
DC-55	55	50.0		2.15	2.50	2.00		48.50		6.50	10.40	61.50	63.0	7.5	43.00	34.00	2.00	12.00	7000	

ALL DIMENSIONS IN MILLIMETERS.

\*The radius "R" on the load side must not exceed 0.1 T

\*\*\* FOR PLATED RINGS, ADD 0.05 TO THE LISTED MAXIMUM THICKNESS. MAXIMUM RING THICKNESS WILL BE A MINIMUM OF 0.005 LESS THAN THE LISTED GROOVE WIDTH (W) MIN.

HARDNESS RANGES: STAINLESS STEEL RINGS (PH 15-7MO)

RING TYPE	SIZE RANGE	HARDNESS		
		VICKERS	ROCKWELL	
			HRC	LOWER SCALE*
DC	3 & 4	435-530	44-51	82.5-86 HR15N**
	5-17	435-530	44-51	63-69.5 HR30N
	18-55	435-530	44-51	-

\*WHERE APPLICABLE

\*\*HARDNESS CAN NOT BE CHECKED WITH ANY DEGREE OF ACCURACY DIRECTLY ON THESE RINGS.

HARDNESS RANGES: CARBON STEEL RINGS (SAE 1060-1090)

RING TYPE	SIZE RANGE	HARDNESS		
		VICKERS	ROCKWELL	
			HRC	LOWER SCALE*
DC	3 & 4	485-545	48-52	84.5-86.5 HR15N**
	5-17	485-545	48-52	66.5-70.5 HR30N
	18-55	485-545	48-52	-

\*WHERE APPLICABLE

\*\*HARDNESS CAN NOT BE CHECKED WITH ANY DEGREE OF ACCURACY DIRECTLY ON THESE RINGS.

HARDNESS RANGES: STAINLESS STEEL RINGS (DIN 1.4122 X39CrMo17)

RING TYPE	SIZE RANGE	HARDNESS			
		HV	HRC	15N	30N
DC	ALL	470-580	47-54	84-87.5	66-72





# DTX Shaft Rings

## Self-Locking, External "Push-On", Metric

This ring features a curved outer rim with a series of prongs protruding into the center. The ends create interference with the shaft when the ring is installed and a load introduced to the other side.

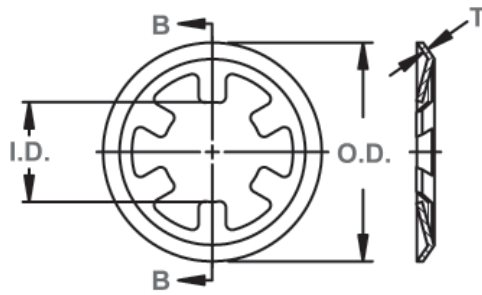

Free Diameter & Ring Measurements  
With Section B-B

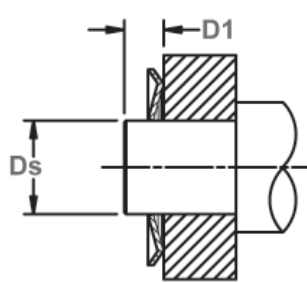

Installation View  
Without Groove

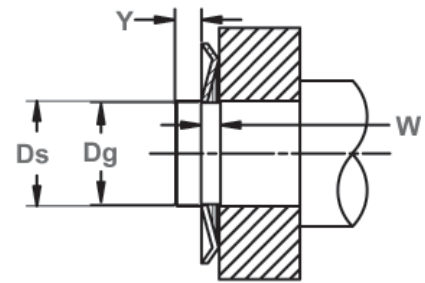

Installation View  
With Groove

RING NO.	SHAFT DIAMETER		GROOVE SIZE DIMENSIONS			RING DIMENSIONS				SUPPLEMENTARY DATA			
						I.D.	O.D.	No. Of Prongs	THICKNESS	WEIGHT Per 1000	Min. Dis-tance	THRUST LOAD	EDGE MARGIN
Ds	TOL.	Dg	Tol.	W Min.	I.D.	O.D.	T	kg.	D1	N	Y		
DTX-1,5	1,5		1,40		0,4	1,40	6,0	3	0,25	0,040	1,5	100	1,0
DTX-2	2,0	+0,00	1,90	-0,060	0,4	1,85	6,5	3	0,25	0,042	1,5	150	1,0
DTX-3	3,0	-0,060	2,90		0,4	2,80	8,0	4	0,25	0,066	1,5	200	1,0
DTX-4	4,0		3,90		0,4	3,80	9,0	4	0,25	0,078	2,0	220	1,0
DTX-5	5,0	+0,00	4,90	-0,075	0,4	4,80	10,0	4	0,25	0,082	2,0	230	1,0
DTX-6	6,0	-0,075	5,90		0,4	5,80	11,0	4	0,25	0,094	2,5	240	1,5
DTX-7	7,0		6,90		0,4	6,80	12,0	5	0,25	0,110	2,5	250	1,5
DTX-8	8,0	+0,00	7,85	-0,090	0,4	7,75	13,0	5	0,25	0,122	2,5	250	1,5
DTX-9	9,0	-0,090	8,85		0,6	8,75	14,0	5	0,30	0,208	2,5	300	1,5
DTX-10	10,0		9,85		0,6	9,75	16,0	6	0,30	0,232	3,0	320	1,5
DTX-12	12,0		11,85		0,6	11,70	18,0	6	0,30	0,255	3,0	350	1,5
DTX-14	14,0	+0,00	13,80	-0,110	0,6	13,70	20,5	6	0,30	0,310	3,0	400	1,5
DTX-15	15,0	-0,110	14,80		1,0	14,60	23,0	8	0,50	0,750	3,0	600	2,0
DTX-16	16,0		15,80		1,0	15,60	24,5	8	0,40	0,710	3,0	700	2,0
DTX-17	17,0		16,80		1,0	16,60	26,0	8	0,50	0,950	3,5	800	2,0
DTX-18	18,0		17,80		1,0	17,60	27,0	8	0,40	0,810	3,5	850	2,0
DTX-19	19,0		18,80		1,0	18,60	28,0	8	0,50	0,950	3,5	900	2,0
DTX-20	20,0		19,75		1,0	19,50	29,0	8	0,50	1,090	3,5	950	2,0
DTX-22	22,0		21,75		1,0	21,50	31,0	8	0,50	1,150	3,5	1000	2,0
DTX-23	23,0	+0,00	22,75	-0,130	1,0	22,50	31,5	8	0,50	1,220	4,0	1050	2,0
DTX-25	25,0	-0,130	24,75		1,0	24,50	34,0	8	0,50	1,490	4,0	1100	2,0
DTX-28	28,0		27,75		1,0	27,50	37,0	8	0,50	1,550	4,0	1200	2,0
DTX-30	30,0		29,75		1,0	29,50	40,0	8	0,50	1,630	4,0	1300	2,0
DTX-35	35,0	+0,00	34,75		1,0	34,50	46,0	8	0,50	2,100	4,0	1400	2,0
DTX-45	45,0	-0,160	44,75		1,5	44,50	60,0	8	0,50	2,700	4,0	1500	2,0

ALL DIMENSIONS IN MILLIMETERS.

HARDNESS RANGES: STAINLESS STEEL RINGS (DIN 1.4122 X39CrMo17)

RING TYPE	SIZE RANGE	HARDNESS			
		HV	HRC	15N	30N
DTX	ALL	470-580	47-54	84-87.5	66-72

HARDNESS RANGES: STAINLESS STEEL RINGS (PH 15-7MO)

RING TYPE	SIZE RANGE	HARDNESS			
		VICKERS	ROCKWELL		
			HRC	LOWER SCALE*	
DTX	1.5-14	435-530	44-51	82.5-86 HR15N**	
	15-45	435-530	44-51	82.5-86 HR15N	

\*WHERE APPLICABLE

\*\*HARDNESS CAN NOT BE CHECKED WITH ANY DEGREE OF ACCURACY DIRECTLY ON THESE RINGS.

HARDNESS RANGES: CARBON STEEL RINGS (SAE 1060-1090)

RING TYPE	SIZE RANGE	HARDNESS			
		VICKERS	ROCKWELL		
			HRC	LOWER SCALE*	
DTX	1.5-14	450-520	45-50	83-85.5 HR15N**	
	15-45	450-520	45-50	83-85.5 HR15N	

\*WHERE APPLICABLE

\*\*HARDNESS CAN NOT BE CHECKED WITH ANY DEGREE OF ACCURACY DIRECTLY ON THESE RINGS.

# Self-Locking, Internal "Push-On", Metric

The internal version of the TX with a curved inner rim and a series of prongs protruding outward. The ends create interference with the housing when the ring is installed and a load introduced to the other side.

# DTI Housing Rings

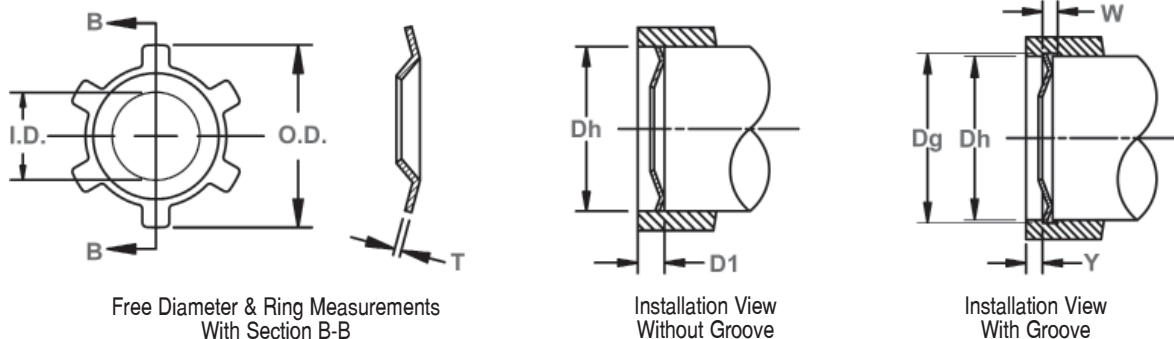

RING NO.	HOUSING DIAMETER		GROOVE SIZE DIMENSIONS			RING DIMENSIONS				SUPPLEMENTARY DATA			
						No. Of Prongs	THICK-NESS	WEIGHT Per 1000 Pcs.	Min. Dis-tance	THRUST LOAD	EDGE MARGIN		
												I.D.	O.D.
DTI-8	Dh	TOL.	Dg	Tol.	W Min.	I.D.	O.D.		T	kg.	D1	N	Y
DTI-8	8,0	+0,09	8,10	+0,060	0,4	4,0	8,25	6	0,25	0,048	2,0	300	1,0
DTI-10	10,0	-0,00	10,10		0,4	5,0	10,20	6	0,25	0,068	2,0	350	1,0
DTI-12	12,0		12,10		0,4	6,0	12,25	6	0,25	0,112	2,5	450	1,0
DTI-14	14,0		14,10		0,5	8,0	14,25	6	0,30	0,172	2,5	500	1,0
DTI-15	15,0	+0,11	15,10	+0,075	0,5	9,0	15,25	6	0,30	0,192	2,5	550	1,0
DTI-16	16,0	-0,00	16,15		0,5	10,0	16,30	6	0,30	0,206	2,5	600	1,5
DTI-17	17,0		17,15		0,5	11,0	17,30	8	0,30	0,236	3,0	650	1,5
DTI-18	18,0		18,15		0,8	10,5	18,30	8	0,40	0,380	3,0	700	1,5
DTI-19,8	19,8		20,00		0,8	11,0	20,20	8	0,50	0,604	3,5	800	1,5
DTI-20	20,0		20,20	+0,110	0,8	11,0	20,35	8	0,40	0,512	3,5	800	1,5
DTI-22	22,0	+0,13	22,20		1,0	13,0	22,35	8	0,50	0,680	3,5	800	2,0
DTI-25	25,0	-0,00	25,20		1,0	16,0	25,35	10	0,50	0,810	3,5	800	2,0
DTI-26	26,0		26,20		1,0	17,0	26,40	10	0,50	0,856	3,5	850	2,0
DTI-28	28,0		28,20		1,0	19,0	28,40	10	0,50	0,922	3,5	850	2,0
DTI-30	30,0		30,20		1,0	21,0	30,40	8	0,50	1,010	4,0	900	2,0
DTI-32	32,0		32,20		1,0	22,5	32,40	12	0,50	1,210	4,0	900	2,0
DTI-35	35,0	+0,160	35,20	+0,130	1,0	25,0	35,40	12	0,50	1,320	4,0	900	2,0
DTI-40	40,0	-0,00	40,20		1,0	30,0	40,40	12	0,50	1,720	4,0	950	2,0
DTI-45	45,0		45,20		1,0	35,0	45,40	12	0,50	1,830	4,0	950	2,0
DTI-46	46,0		46,20		1,0	36,0	46,50	12	0,50	1,870	4,0	1000	2,0
DTI-50	50,0		50,20		1,0	39,0	50,50	12	0,50	2,160	4,0	1000	2,0

ALL DIMENSIONS IN MILLIMETERS.

HARDNESS RANGES: STAINLESS STEEL RINGS (DIN 1.4122 X39CrMo17)

RING TYPE	SIZE RANGE	HARDNESS			
		HV	HRC	15N	30N
DTI	ALL	470-580	47-54	84-87.5	66-72

HARDNESS RANGES: STAINLESS STEEL RINGS (PH 15-7MO)

RING TYPE	SIZE RANGE	HARDNESS		
		VICKERS	ROCKWELL	
			HRC	LOWER SCALE*
DTI	8-20***	435-530	44-51	82.5-86 HR15N**
	19.8, 22-50	435-530	44-51	82.5-86 HR15N

\*WHERE APPLICABLE

\*\*HARDNESS CAN NOT BE CHECKED WITH ANY DEGREE OF ACCURACY DIRECTLY ON THESE RINGS.

\*\*\*EXCLUDING DTI-19.8

HARDNESS RANGES: CARBON STEEL RINGS (SAE 1060-1090)

RING TYPE	SIZE RANGE	HARDNESS		
		VICKERS	ROCKWELL	
			HRC	LOWER SCALE*
DTI	8-20***	450-520	45-50	83-85.5 HR15N**
	19.8, 22-50	450-520	45-50	83-85.5 HR15N

\*WHERE APPLICABLE

\*\*HARDNESS CAN NOT BE CHECKED WITH ANY DEGREE OF ACCURACY DIRECTLY ON THESE RINGS.

\*\*\*EXCLUDING DTI-19.8



# MHO Housing Rings

## Axially Assembled, Internal, ANSI Metric

Once installed in the groove of a housing/bore, the portion of the ring protruding from the groove (also called a "shoulder") holds an assembly in place.

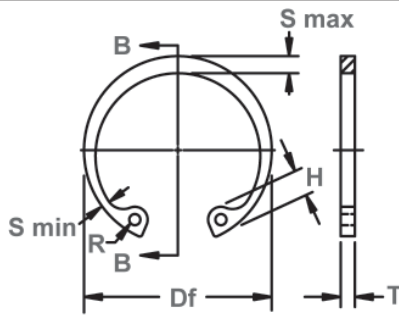

Free Diameter & Ring Measurements  
With Section B-B

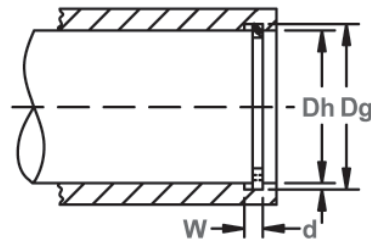

Housing Diameter &  
Groove Dimensions

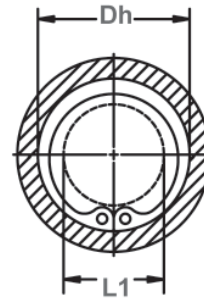

Clearance Diameter  
Compressed In Housing

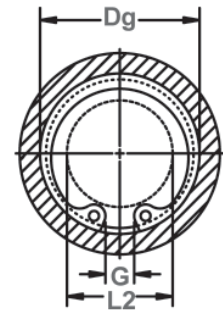

Clearance Diameter & Gap  
Width Released In Groove

RING NO.	HOUSING DIAMETER		GROOVE SIZE						RING SIZE & WEIGHT				CLEARANCE DIA.		i THRUST LD (kN)		
			DIAMETER			WIDTH		DEPTH	FREE DIAMETER		THICKNESS***	Wt. Per 1000 pcs.	Compressed in housing	Released in Groove	Sqr. corner abutment		
	Ds mm	Ds INCH	Dg	tol	F.I.M.*	W	tol	d	Df	tol	T	tol	kg	L1	L2	Pr	Pg
MHO-8	8	0.315	8.40	+0.06	0.03	0.50	+0.10	0.20	8.80		0.4		0.05	4.4	4.8	2.4	1.0
MHO-9	9	0.354	9.45		0.03	0.70		0.23	10.00		0.6		0.11	4.6	5.0	4.4	1.2
MHO-10	10	0.393	10.50		0.03	0.70		0.25	11.10		0.6		0.14	5.5	6.0	4.9	1.5
MHO-11	11	0.433	11.60		0.05	0.70		0.30	12.20		0.6		0.17	5.7	6.3	5.4	2.0
MHO-12	12	0.472	12.65		0.05	0.70		0.33	13.30		0.6		0.19	6.7	7.3	5.8	2.4
MHO-13	13	0.512	13.70		0.05	1.00		0.35	14.25	+0.25	0.9		0.35	6.8	7.5	8.9	2.6
MHO-14	14	0.551	14.80	+0.10	0.05	1.00		0.40	15.45	-0.13	0.9		0.39	6.9	7.7	9.7	3.2
MHO-15	15	0.591	15.85		0.05	1.00		0.43	16.60		0.9		0.42	7.9	8.7	10.4	3.7
MHO-16	16	0.630	16.90		0.10	1.00		0.45	17.70		0.9		0.47	8.8	9.7	11.0	4.2
MHO-17	17	0.669	18.00		0.10	1.00		0.50	18.90		0.9		0.52	9.8	10.8	11.7	4.9
MHO-18	18	0.708	19.05		0.10	1.00		0.53	20.05		0.9		0.58	10.3	11.3	12.3	5.5
MHO-19	19	0.748	20.10		0.10	1.00		0.55	21.10		0.9		0.59	11.4	12.5	13.1	6.0
MHO-20	20	0.787	21.15		0.10	1.00		0.57	22.25		0.9		0.70	11.6	12.7	13.7	6.6
MHO-21	21	0.826	22.20		0.10	1.00	+0.15	0.60	23.30		0.9	±0.06	0.82	12.6	13.8	14.5	7.3
MHO-22	22	0.866	23.30		0.10	1.20		0.65	24.40		1.1		0.90	13.5	14.8	22.5	8.3
MHO-23	23	0.905	24.35	+0.15	0.10	1.20		0.67	25.45	+0.40	1.1		1.00	14.5	15.9	23.5	8.9
MHO-24	24	0.945	25.40		0.10	1.20		0.70	26.55	-0.25	1.1		1.09	15.5	16.9	24.8	9.7
MHO-25	25	0.984	26.60		0.10	1.20		0.80	27.75		1.1		1.26	16.5	18.1	25.7	11.6
MHO-26	26	1.023	27.70		0.15	1.20		0.85	28.85		1.1		1.3	17.5	19.2	26.8	12.7
MHO-27	27	1.063	28.80		0.15	1.40		0.90	29.95		1.3		1.7	17.4	19.2	33.0	14.0
MHO-28	28	1.102	29.80		0.15	1.40		0.90	31.10		1.3		1.8	18.2	20.0	34.0	14.6
MHO-30	30	1.181	31.90		0.15	1.40		0.95	33.40		1.3		2.0	20.0	21.9	37.0	16.5
MHO-32	32	1.260	33.90		0.15	1.40		0.95	35.35	+0.65	1.3		2.2	22.0	23.9	39.0	17.6
MHO-34	34	1.339	36.10		0.15	1.40		1.05	37.75	-0.50	1.3		2.3	24.0	26.1	42.0	20.6
MHO-35	35	1.378	37.20	+0.20	0.15	1.40		1.10	38.75		1.3		2.3	25.0	27.2	43.0	22.3
MHO-36	36	1.417	38.30		0.15	1.40		1.15	40.00		1.3		2.6	26.0	28.3	44.0	23.9
MHO-37	37	1.457	39.30		0.15	1.40		1.15	41.05		1.3		2.9	27.0	29.3	45.0	24.6
MHO-38	38	1.496	40.40		0.15	1.40		1.20	42.15		1.3		3.0	28.0	30.4	46.0	26.4

\* F.I.M. (FULL INDICATOR MOVEMENT)- MAXIMUM ALLOWABLE DEVIATION OF CONCENTRICITY BETWEEN GROOVE & HOUSING.

i BASED ON HOUSINGS/SHAFTS MADE OF COLD ROLLED STEEL. FOR AN EXPLANATION OF FORMULAS USED TO DERIVE THRUST LOAD AND OTHER PERFORMANCE DATA CONTACT THE ROTOR CLIP ENGINEERING DEPARTMENT.

\*\*\*FOR PLATED RINGS ADD 0.05 TO THE LISTED MAXIMUM THICKNESS. MAXIMUM THICKNESS WILL BE A MINIMUM OF 0.005 LESS THAN THE LISTED GROOVE WIDTH (W) MINIMUM.

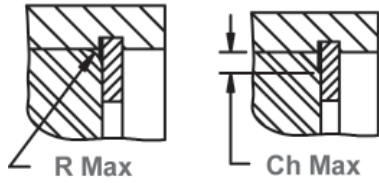

Allowable Corner Radius & Chamfer

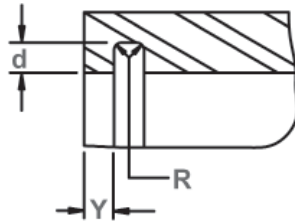

Exploded Groove Profile & Edge Margin (Y)  
 Maximum bottom radii (R), 0.10 for ring sizes  
 -8 thru -17; 0.2 for ring sizes -18 thru -30;  
 0.3 for ring sizes -32 thru -55  
 0.4 for ring sizes -56 thru -250

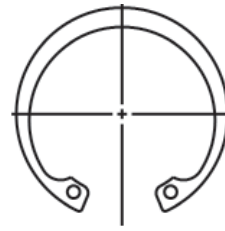

Alternate Lug Design  
 For Larger Sizes  
 (Manufacturer's Option)



Alternate Design  
 (Manufacturer's Option)

RING NO.	LUG HEIGHT	MAXIMUM SECTION	MINIMUM SECTION	HOLE DIAMETER	GAP WIDTH Ring in Groove	ALLOWABLE CORNER RADII & CHAMFERS		MAX. LOAD w/ R max or Ch max	EDGE MARGIN
						R max	Ch max		
	H nom	S max/Ref.	S min/Ref.	R min	G	R max	Ch max	P'r	Y
MHO-8	1.7	0.85	0.45	0.8	1.40	0.4	0.3	0.8	0.6
MHO-9	2.1	1.25	0.65	1.0	1.50	0.5	0.35	2.0	0.7
MHO-10	2.1	1.30	0.70	1.0	1.85	0.5	0.35	2.0	0.8
MHO-11	2.5	1.30	0.70	1.0	1.95	0.6	0.4	2.0	0.9
MHO-12	2.5	1.35	0.75	1.0	2.25	0.6	0.4	2.0	1.0
MHO-13	2.9	1.35	0.90	1.2	2.35	0.7	0.5	4.0	1.1
MHO-14	3.3	1.60	0.90	1.2	2.65	0.7	0.5	4.0	1.2
MHO-15	3.3	1.65	0.95	1.5	2.80	0.7	0.5	4.0	1.3
MHO-16	3.4	1.70	0.95	1.5	2.80	0.7	0.5	4.0	1.4
MHO-17	3.4	1.70	0.95	1.5	3.35	0.75	0.6	4.0	1.5
MHO-18	3.6	1.80	1.00	1.5	3.40	0.75	0.6	4.0	1.6
MHO-19	3.6	1.80	1.00	1.5	3.40	0.8	0.65	4.0	1.7
MHO-20	4.0	2.00	1.10	1.5	3.80	0.9	0.7	4.0	1.7
MHO-21	4.0	2.10	1.20	1.5	4.20	0.9	0.7	4.0	1.8
MHO-22	4.0	2.10	1.20	1.5	4.30	0.9	0.7	7.4	1.9
MHO-23	4.0	2.20	1.20	1.5	4.90	1.0	0.8	7.4	2.0
MHO-24	4.0	2.30	1.30	1.5	5.20	1.0	0.8	7.4	2.1
MHO-25	4.0	2.60	1.30	1.5	6.00	1.0	0.8	7.4	2.4
MHO-26	4.0	2.70	1.40	1.5	5.70	1.2	1.0	7.4	2.6
MHO-27	4.6	2.80	1.40	1.9	5.90	1.2	1.0	10.8	2.7
MHO-28	4.6	2.90	1.50	1.9	6.00	1.2	1.0	10.8	2.7
MHO-30	4.6	3.00	1.50	1.9	6.00	1.2	1.0	10.8	2.9
MHO-32	4.6	3.10	1.60	1.9	7.30	1.2	1.0	10.8	2.9
MHO-34	4.6	3.20	1.60	1.9	7.60	1.2	1.0	10.8	3.2
MHO-35	4.6	3.30	1.60	1.9	8.00	1.2	1.0	10.8	3.3
MHO-36	4.6	3.40	1.70	1.9	8.30	1.2	1.0	10.8	3.5
MHO-37	4.6	3.40	1.70	1.9	8.40	1.2	1.0	10.8	3.5
MHO-38	4.6	3.40	1.70	1.9	8.60	1.2	1.0	10.8	3.6

FOR HARDNESS SPECIFICATIONS, SEE END OF THE SECTION.

# MHO Housing Rings

## Axially Assembled, Internal, ANSI Metric

Once installed in the groove of a housing/bore, the portion of the ring protruding from the groove (also called a "shoulder") holds an assembly in place.

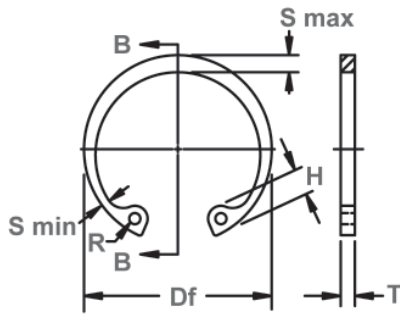

Free Diameter & Ring Measurements  
With Section B-B

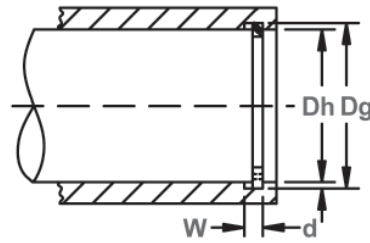

Housing Diameter &  
Groove Dimensions

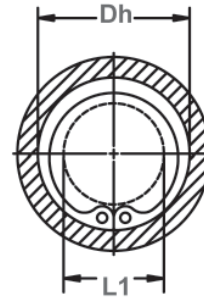

Clearance Diameter  
Compressed In Housing

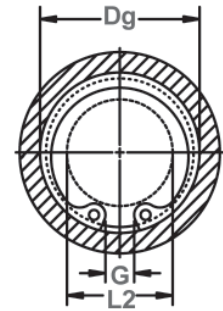

Clearance Diameter & Gap  
Width Released In Groove

RING NO.	HOUSING DIAMETER		GROOVE SIZE						RING SIZE & WEIGHT				CLEARANCE DIA.		THRUST LD (kN)		
			DIAMETER			WIDTH		DEPTH	FREE DIAMETER		THICKNESS***		Com-pressed in housing	Re-leased in Groove	Sqr. corner abutment		
	Ds mm	Ds INCH	Dg	tol	F.I.M.*	W	tol	d	Df	tol	T	tol	kg	L1	L2	Pr	Pg
MHO-40	40	1.575	42.40		0.15	1.75		1.20	44.25		1.6		4.0	29.2	31.6	62.0	27.7
MHO-42	42	1.654	44.50		0.15	1.75		1.25	46.60		1.6		4.7	29.7	32.2	65.0	30.2
MHO-45	45	1.772	47.60		0.15	1.75		1.30	49.95	+0.90	1.6		5.1	32.3	34.9	69.0	33.8
MHO-46	46	1.811	48.70	+0.20	0.20	1.75	+0.20	1.35	51.05	-0.65	1.6		5.2	33.3	36.0	71.0	36.0
MHO-47	47	1.850	49.80		0.20	1.75		1.40	52.15		1.6		5.8	34.3	37.1	72.0	38.0
MHO-48	48	1.890	50.90		0.20	1.75		1.45	53.30		1.6		6.1	35.0	37.9	74.0	40.0
MHO-50	50	1.969	53.10		0.20	1.75		1.55	55.35		1.6		6.2	36.9	40.0	77.0	45.0
MHO-52	52	2.047	55.30		0.20	2.15		1.65	57.90		2.0		8.1	38.6	41.9	99.0	50.0
MHO-55	55	2.165	58.40		0.20	2.15		1.70	61.10		2.0		8.9	40.8	44.2	105.0	54.0
MHO-57	57	2.244	60.50		0.20	2.15		1.75	63.25		2.0		9.9	42.2	45.7	109.0	58.0
MHO-58	58	2.283	61.60		0.20	2.15		1.80	64.40		2.0		10.1	43.2	46.8	111.0	60.0
MHO-60	60	2.362	63.80		0.20	2.15		1.90	66.80		2.0	±0.08	10.5	45.5	49.3	115.0	66.0
MHO-62	62	2.441	65.80		0.20	2.15		1.90	68.60	+1.00	2.0		11.5	47.0	50.8	119.0	68.0
MHO-63	63	2.480	66.90		0.20	2.15		1.95	69.90	-0.75	2.0		11.6	47.8	51.7	120.0	71.0
MHO-65	65	2.559	69.00		0.20	2.55		2.00	72.20		2.4		15.4	49.4	53.4	149.0	75.0
MHO-68	68	2.677	72.20	+0.30	0.20	2.55	+0.20	2.10	75.70		2.4		15.9	52.0	56.2	156.0	82.0
MHO-70	70	2.756	74.40		0.20	2.55		2.20	77.50		2.4		16.1	53.8	58.2	161.0	88.0
MHO-72	72	2.835	76.50		0.20	2.55		2.25	79.60		2.4		16.3	55.9	60.4	166.0	93.0
MHO-75	75	2.953	79.70		0.20	2.55		2.35	83.30		2.4		19.3	58.2	62.9	172.0	101.0
MHO-78	78	3.071	82.80		0.20	2.95		2.40	86.80		2.8		24.0	61.2	66.0	209.0	108.0
MHO-80	80	3.150	85.00		0.20	2.95		2.50	89.10		2.8		25.9	63.0	68.0	215.0	115.0
MHO-82	82	3.228	87.20		0.25	2.95		2.60	91.10	+1.40	2.8		27.2	63.5	68.7	220.0	122.0
MHO-85	85	3.346	90.40		0.25	2.95		2.70	94.40	-1.40	2.8		29.5	66.8	72.2	228.0	131.0
MHO-88	88	3.464	93.60		0.25	2.95		2.80	97.90		2.8		31.3	69.6	75.2	236.0	141.0
MHO-90	90	3.543	95.70		0.25	2.95		2.85	100.00		2.8		32.6	71.6	77.3	241.0	147.0
MHO-92	92	3.622	97.80		0.25	2.95		2.90	102.20		2.8		33.1	73.6	79.4	247.0	153.0

\* F.I.M. (FULL INDICATOR MOVEMENT)- MAXIMUM ALLOWABLE DEVIATION OF CONCENTRICITY BETWEEN GROOVE & HOUSING.

† BASED ON HOUSINGS/SHAFTS MADE OF COLD ROLLED STEEL. FOR AN EXPLANATION OF FORMULAS USED TO DERIVE THRUST LOAD AND OTHER PERFORMANCE DATA CONTACT THE ROTOR CLIP ENGINEERING DEPARTMENT.

\*\*\*FOR PLATED RINGS ADD 0.05 TO THE LISTED MAXIMUM THICKNESS. MAXIMUM THICKNESS WILL BE A MINIMUM OF 0.005 LESS THAN THE LISTED GROOVE WIDTH (W) MINIMUM.



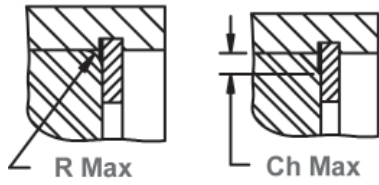

Allowable Corner Radius & Chamfer

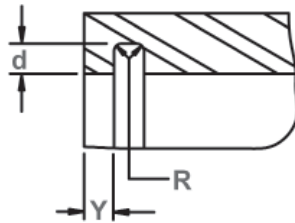

Exploded Groove Profile & Edge Margin (Y)  
 Maximum bottom radii (R), 0.10 for ring sizes  
 -8 thru -17; 0.2 for ring sizes -18 thru -30;  
 0.3 for ring sizes -32 thru -55  
 0.4 for ring sizes -56 thru -250

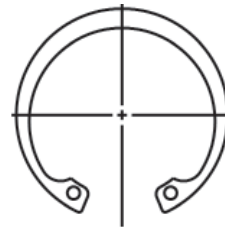

Alternate Lug Design  
 For Larger Sizes  
 (Manufacturer's Option)



Alternate Design  
 (Manufacturer's Option)

RING NO.	LUG HEIGHT	MAXIMUM SECTION	MINIMUM SECTION	HOLE DIAMETER	GAP WIDTH Ring in Groove	ALLOWABLE CORNER RADII & CHAMFERS		MAX. LOAD w/ R max or Ch max	EDGE MARGIN
						R max	Ch max		
	H nom	S max/Ref.	S min/Ref.	R min	G			P'r	Y
MHO-40	5.1	4.00	2.00	1.9	9.70	1.7	1.3	17.4	3.6
MHO-42	5.8	4.20	2.10	1.9	9.00	1.7	1.3	17.4	3.7
MHO-45	6.0	4.30	2.10	1.9	9.60	1.7	1.3	17.4	3.9
MHO-46	6.0	4.30	2.10	2.3	9.70	1.7	1.3	17.4	4.0
MHO-47	6.0	4.30	2.20	2.3	10.00	1.7	1.3	17.4	4.2
MHO-48	6.0	4.50	2.30	2.3	10.50	1.7	1.3	17.4	4.3
MHO-50	6.0	4.60	2.30	2.3	12.10	1.7	1.3	17.4	4.6
MHO-52	6.4	4.70	2.30	2.3	11.70	2.0	1.6	27.4	5.0
MHO-55	6.7	5.10	2.50	2.3	11.90	2.0	1.6	27.4	5.1
MHO-57	6.9	5.20	2.50	2.3	12.50	2.0	1.6	27.4	5.3
MHO-58	6.9	5.30	2.60	2.3	13.00	2.0	1.6	27.4	5.4
MHO-60	6.9	5.30	2.60	2.3	12.70	2.0	1.6	27.4	5.7
MHO-62	7.1	5.30	2.60	2.7	14.00	2.0	1.6	27.4	5.7
MHO-63	7.1	5.40	2.70	2.7	14.20	2.0	1.6	27.4	5.9
MHO-65	7.4	5.60	2.80	2.7	14.20	2.0	1.6	42.0	6.0
MHO-68	7.6	5.80	2.90	2.7	14.40	2.3	1.8	39.0	6.3
MHO-70	7.6	5.80	2.90	2.7	16.10	2.3	1.8	39.0	6.6
MHO-72	7.6	5.80	2.90	2.7	17.40	2.3	1.8	39.0	6.7
MHO-75	7.9	6.20	3.10	2.7	16.80	2.3	1.8	54.0	7.1
MHO-78	7.9	6.50	3.20	3.1	17.60	2.5	2.0	54.0	7.2
MHO-80	7.9	6.70	3.30	3.1	17.20	2.5	2.0	54.0	7.5
MHO-82	8.7	6.90	3.40	3.1	18.80	2.6	2.1	54.0	7.8
MHO-85	8.7	7.00	3.60	3.1	19.10	2.6	2.1	54.0	8.1
MHO-88	8.7	7.30	3.60	3.1	20.40	2.8	2.2	54.0	8.4
MHO-90	8.7	7.40	3.60	3.1	21.40	2.8	2.2	54.0	8.6
MHO-92	8.7	7.60	3.80	3.1	22.20	2.9	2.4	54.0	8.7

FOR HARDNESS SPECIFICATIONS, SEE END OF THE SECTION.

# MHO Housing Rings

## Axially Assembled, Internal, ANSI Metric

Once installed in the groove of a housing/bore, the portion of the ring protruding from the groove (also called a "shoulder") holds an assembly in place.

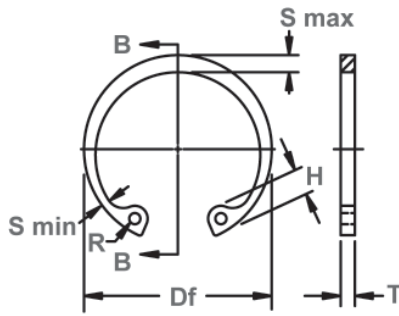

Free Diameter & Ring Measurements  
With Section B-B

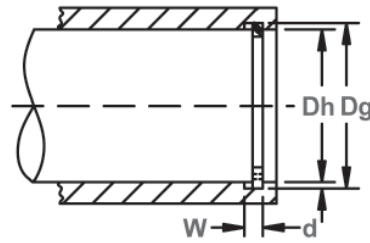

Housing Diameter &  
Groove Dimensions

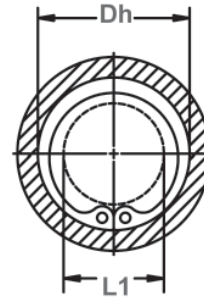

Clearance Diameter  
Compressed In Housing

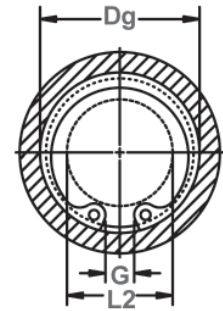

Clearance Diameter & Gap  
Width Released In Groove

RING NO.	HOUSING DIAMETER		GROOVE SIZE						RING SIZE & WEIGHT				CLEARANCE DIA.		i THRUST LD (kN)		
			DIAMETER			WIDTH		DEPTH	FREE DIAMETER		THICKNESS***		Com-pressed in housing	Re-leased in Groove	Ring (Safety Factor of 4)	Groove (Safety Factor of 2)	
	Ds mm	Ds INCH	Dg	tol	F.I.M.*	W	tol	d	Df	tol	T	tol	kg	L1	L2	Pr	Pg
MHO-95	95	3.740	101.00	+0.30	0.25	2.95		3.00	105.60		2.8		35.4	76.7	82.7	255.0	164.0
MHO-98	98	3.858	104.20		0.25	2.95		3.10	109.00		2.8		39.4	78.3	84.5	263.0	174.0
MHO-100	100	3.937	106.30		0.25	2.95		3.15	110.70		2.8		39.9	80.3	86.6	269.0	181.0
MHO-102	102	4.016	108.40		0.25	2.95		3.20	112.40		2.8		42.2	82.2	88.6	273.0	187.0
MHO-105	105	4.134	111.50		0.25	2.95	+0.20	3.25	115.80		2.8		44.0	85.1	91.6	281.0	196.0
MHO-108	108	4.252	114.60		0.25	2.95		3.30	119.20		2.8		45.8	88.1	94.7	290.0	205.0
MHO-110	110	4.331	116.70		0.25	2.95		3.35	120.80	+1.65	2.8		47.6	88.4	95.1	295.0	212.0
MHO-115	115	4.528	121.90		0.25	2.95		3.45	126.00	-1.65	2.8		50.3	93.2	100.1	309.0	227.0
MHO-120	120	4.724	127.00		0.25	2.95		3.50	132.40		2.8		56.2	98.2	105.2	321.0	241.0
MHO-125	125	4.921	132.10	+0.40	0.25	2.95		3.55	137.10		2.8		60.0	103.1	110.2	335.0	255.0
MHO-130	130	5.118	137.20		0.25	2.95		3.60	142.50		2.8		63.5	108.0	115.2	349.0	269.0
MHO-135	135	5.315	142.30		0.25	3.40		3.65	148.50		3.2		79	110.4	117.7	415.0	283.0
MHO-140	140	5.512	147.40		0.25	3.40		3.70	154.10		3.2		83	115.3	122.7	429.0	298.0
MHO-145	145	5.709	152.50		0.25	3.40		3.75	159.50		3.2		87	120.4	127.9	444.0	313.0
MHO-150	150	5.906	157.60		0.25	3.40		3.80	164.50		3.2		89	125.3	132.9	460.0	327.0
MHO-155	155	6.102	162.70		0.30	3.40		3.85	168.80		3.2		91	130.4	138.1	475.0	343.0
MHO-160	160	6.299	167.80		0.30	4.25		3.90	175.10		4.0		121	133.8	141.6	613.0	359.0
MHO-165	165	6.496	172.90		0.30	4.25		3.95	180.30	+2.05	4.0		127	138.7	146.6	632.0	374.0
MHO-170	170	6.693	178.00		0.30	4.25		4.00	185.60	-2.05	4.0		138	143.6	151.6	651.0	390.0
MHO-175	175	6.890	183.20		0.30	4.25	+0.25	4.10	191.30		4.0		147	146.0	154.2	670.0	403.0
MHO-180	180	7.087	188.40		0.30	4.25		4.20	196.60		4.0		156	151.4	159.8	690.0	434.0
MHO-185	185	7.283	193.60		0.30	5.10		4.30	202.70		4.8		194	154.7	163.3	851.0	457.0
MHO-190	190	7.480	198.80		0.30	5.10		4.40	207.70		4.8		220	159.5	168.3	873.0	480.0
MHO-200	200	7.874	209.00	+0.50	0.30	5.10		4.50	217.80		4.8		235	169.2	178.2	919.0	517.0
MHO-210	210	8.268	219.40		0.30	5.10		4.70	230.30	+2.30	4.8		275	177.5	186.9	965.0	566.0
MHO-220	220	8.661	230.00		0.30	5.10		5.00	240.50	-2.30	4.8		285	184.1	194.1	1000.0	608.0
MHO-230	230	9.055	240.60		0.30	5.10		5.30	251.40		4.8		330	194.0	204.6	1060.0	686.0
MHO-240	240	9.449	251.00		0.30	5.10		5.50	262.30		4.8		365	200.4	211.4	1090.0	725.0
MHO-250	250	9.843	261.40		0.30	5.10		5.70	273.30		4.8		375	210.0	221.4	1150.0	808.0

\* F.I.M. (FULL INDICATOR MOVEMENT)- MAXIMUM ALLOWABLE DEVIATION OF CONCENTRICITY BETWEEN GROOVE & HOUSING.

i BASED ON HOUSINGS/SHAFTS MADE OF COLD ROLLED STEEL. FOR AN EXPLANATION OF FORMULAS USED TO DERIVE THRUST LOAD AND OTHER PERFORMANCE DATA CONTACT THE ROTOR CLIP ENGINEERING DEPARTMENT.

\*\*\*FOR PLATED RINGS ADD 0.05 TO THE LISTED MAXIMUM THICKNESS. MAXIMUM THICKNESS WILL BE A MINIMUM OF 0.005 LESS THAN THE LISTED GROOVE WIDTH (W) MINIMUM.

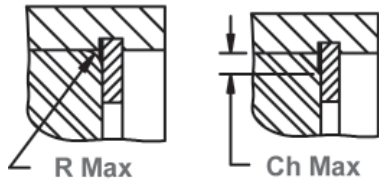

Allowable Corner Radius & Chamfer

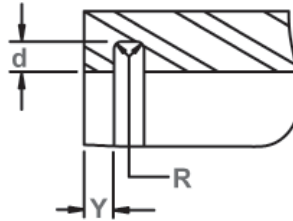

Exploded Groove Profile & Edge Margin (Y)  
 Maximum bottom radii (R), 0.10 for ring sizes  
 -8 thru -17; 0.2 for ring sizes -18 thru -30;  
 0.3 for ring sizes -32 thru -55  
 0.4 for ring sizes -56 thru -250



Alternate Lug Design  
 For Larger Sizes  
 (Manufacturer's Option)



Alternate Design  
 (Manufacturer's Option)

RING NO.	LUG HEIGHT	MAXIMUM SECTION	MINIMUM SECTION	HOLE DIAMETER	GAP WIDTH Ring in Groove	ALLOWABLE CORNER RADII & CHAMFERS		MAX. LOAD w/ R max or Ch max	EDGE MARGIN
						R max	Ch max		
	H nom	S max/Ref.	S min/Ref.	R min	G			P'r	Y
MHO-95	8.7	7.80	3.90	3.1	22.60	3.0	2.5	54.0	9.0
MHO-98	9.4	8.10	4.10	3.1	22.60	3.0	2.5	54.0	9.3
MHO-100	9.4	8.20	4.10	3.1	24.10	3.1	2.5	54.0	9.5
MHO-102	9.4	8.40	4.20	3.1	25.50	3.2	2.6	54.0	9.6
MHO-105	9.4	8.40	4.30	3.1	26.00	3.3	2.6	54.0	9.8
MHO-108	9.4	8.50	4.60	3.1	26.40	3.5	2.7	54.0	9.9
MHO-110	10.3	8.70	4.60	3.8	27.50	3.6	2.8	54.0	10.1
MHO-115	10.3	8.90	4.60	3.8	29.40	3.7	2.9	54.0	10.4
MHO-120	10.3	9.40	4.60	3.8	27.20	3.9	3.1	54.0	10.5
MHO-125	10.3	9.50	4.70	3.8	30.30	4.0	3.2	54.0	10.7
MHO-130	10.3	9.80	4.90	3.8	31.00	4.0	3.2	54.0	10.8
MHO-135	11.6	10.40	5.00	3.8	30.40	4.3	3.4	67.0	11.0
MHO-140	11.6	10.40	5.00	3.8	30.40	4.3	3.4	67.0	11.1
MHO-145	11.6	10.60	5.30	3.8	31.60	4.3	3.4	67.0	11.3
MHO-150	11.6	10.80	5.40	3.8	33.50	4.3	3.4	67.0	11.4
MHO-155	11.6	10.80	5.40	3.8	37.00	4.3	3.4	67.0	11.6
MHO-160	12.3	10.90	5.40	4.6	35.00	4.5	3.6	102.0	11.7
MHO-165	12.3	11.10	5.60	4.6	33.10	4.6	3.7	102.0	11.9
MHO-170	12.3	11.40	5.60	4.6	38.20	4.6	3.7	102.0	12.0
MHO-175	13.5	11.60	5.70	4.6	37.70	4.8	3.8	102.0	12.3
MHO-180	13.5	12.00	5.90	4.6	39.00	5.0	4.0	102.0	12.6
MHO-185	14.2	12.40	6.00	4.6	37.30	5.1	4.1	151.0	12.9
MHO-190	14.2	12.90	6.30	4.6	35.00	5.3	4.3	151.0	13.2
MHO-200	14.2	13.30	6.50	4.6	43.90	5.4	4.3	151.0	13.5
MHO-210	15.2	14.20	6.90	4.6	40.60	5.8	4.6	151.0	14.1
MHO-220	16.8	15.00	7.30	4.6	38.30	6.1	4.9	151.0	15.0
MHO-230	16.8	15.50	7.50	4.6	49.00	6.3	5.1	151.0	15.9
MHO-240	18.7	16.30	7.70	4.6	45.40	6.6	5.3	151.0	16.5
MHO-250	18.7	16.70	7.80	4.6	53.00	6.7	5.4	151.0	17.1

HARDNESS RANGES: STAINLESS STEEL RINGS (PH 15-7MO)

RING TYPE	SIZE RANGE	SCALE	ROCKWELL HARDNESS
MHO	8	15N	82.5-86
	9-26	30N	63-69.5
	27-250	C	44-51

HARDNESS RANGES: CARBON STEEL RINGS (SAE 1060-1090)

RING TYPE	SIZE RANGE	SCALE	ROCKWELL HARDNESS
MHO	8	15N	86-88
	9-13	30N	69.5-73
	14-20	30N	68.5-72
	21-26	30N	67.5-71
	27-250	C	48-52





# MSH Shaft Rings

## Axially Assembled, External, ANSI Metric

Once installed in the groove of a shaft, the portion of the ring protruding from the groove (also called a "shoulder") holds an assembly in place.

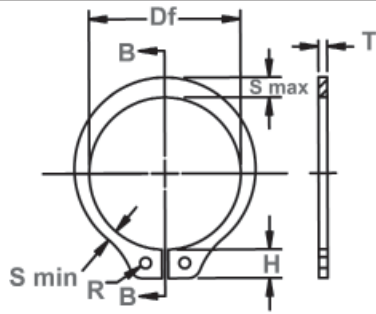

Free Diameter & Ring Measurements with Section B-B

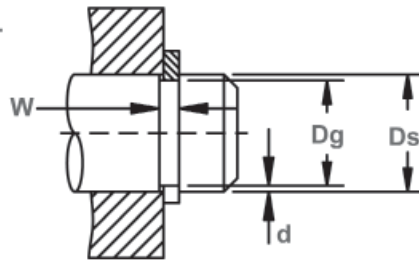

Shaft Diameter & Groove Dimensions

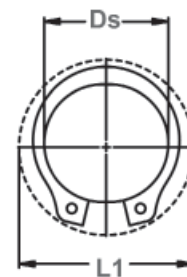

Clearance Diameter Expanded Over Shaft



Clearance Diameter & Gaging Diameter Released in Groove.

RING NO.	SHAFT DIAMETER		GROOVE SIZE						RING SIZE & WEIGHT					CLEARANCE DIA.		THRUST LD (kN)	
			DIAMETER		WIDTH	DEPTH	FREE DIAMETER	THICKNESS ***	Wt. Per 1000 pcs.	Ex-panded over Shaft	Re-leased in Groove	Sqr. corner abutment	Ring (Safety Factor of 4)	Groove (Safety Factor of 2)			
	Ds mm	Ds INCH	Dg	tol	F.I.M.**	W									tol	d	Df
MSH-4*	4	0.157	3.80		0.03	0.32	+0.05	0.10	3.60	+0.05	0.25	±0.05	0.017	7.0	6.8	0.6	0.2
MSH-5*	5	0.197	4.75	-0.08	0.03	0.50	+0.10	0.13	4.55	-0.10	0.40		0.029	8.2	7.9	1.1	0.3
MSH-6*	6	0.236	5.70		0.03	0.50		0.15	5.45		0.40		0.040	9.1	8.8	1.4	0.4
MSH-7	7	0.275	6.60		0.05	0.70		0.20	6.35		0.60		0.10	12.3	11.8	2.6	0.7
MSH-8	8	0.315	7.50	-0.10	0.05	0.70		0.25	7.15		0.60		0.12	13.6	13.0	3.1	1.0
MSH-9	9	0.354	8.45		0.05	0.70		0.28	8.15	+0.05	0.60		0.15	14.5	13.8	3.5	1.2
MSH-10	10	0.393	9.40		0.05	0.70		0.30	9.00	-0.15	0.60		0.19	15.5	14.7	3.9	1.5
MSH-11	11	0.433	10.35		0.05	0.70		0.33	10.00		0.60		0.23	16.4	15.6	4.3	1.8
MSH-12	12	0.472	11.35		0.05	0.70		0.33	10.85		0.60		0.24	17.4	16.6	4.7	2.0
MSH-13	13	0.512	12.30	-0.12	0.10	1.00		0.35	11.90		0.90		0.44	19.7	18.8	7.5	2.2
MSH-14	14	0.551	13.25		0.10	1.00		0.38	12.90		0.90		0.49	20.7	19.7	8.1	2.6
MSH-15	15	0.591	14.15		0.10	1.00		0.43	13.80		0.90		0.54	21.7	20.6	8.7	3.2
MSH-16	16	0.630	15.10		0.10	1.00		0.45	14.70		0.90		0.59	22.7	21.6	9.3	3.5
MSH-17	17	0.669	16.10		0.10	1.00		0.45	15.75		0.90	±0.06	0.64	23.7	22.6	9.9	4.0
MSH-18	18	0.708	17.00		0.10	1.20	+0.15	0.50	16.65		1.10		0.92	26.2	25.0	16.0	4.4
MSH-19	19	0.748	17.95		0.10	1.20		0.53	17.60	+0.15	1.10		0.95	27.2	25.9	16.9	4.9
MSH-20	20	0.787	18.85		0.10	1.20		0.58	18.35	-0.25	1.10		1.0	28.2	26.8	17.8	5.7
MSH-21	21	0.826	19.80	-0.15	0.10	1.20		0.60	19.40		1.10		1.1	29.2	27.7	18.6	6.2
MSH-22	22	0.866	20.70		0.10	1.20		0.65	20.30		1.10		1.3	30.3	28.7	19.6	7.0
MSH-23	23	0.905	21.65		0.10	1.20		0.67	21.25		1.10		1.4	31.3	29.6	20.5	7.6
MSH-24	24	0.945	22.60		0.10	1.20		0.70	22.20		1.10		1.5	34.1	32.4	21.4	8.2
MSH-25	25	0.984	23.50		0.10	1.20		0.75	23.10		1.10		1.6	35.1	33.3	22.3	9.2
MSH-26	26	1.023	24.50		0.10	1.20		0.75	24.05		1.10		1.8	36.0	34.2	23.2	9.6
MSH-27	27	1.063	25.45		0.10	1.40		0.78	24.95		1.30		2.2	37.8	35.9	28.4	10.3
MSH-28	28	1.102	26.40		0.10	1.40		0.80	25.80		1.30		2.3	38.8	36.9	28.4	11.0
MSH-30	30	1.181	28.35		0.15	1.40		0.83	27.90		1.30		2.5	40.8	38.8	31.6	12.3
MSH-32	32	1.260	30.20	-0.20	0.15	1.40		0.90	29.60	+0.25	1.30		2.8	42.8	40.7	33.6	14.1
MSH-34	34	1.339	32.00		0.15	1.40		1.00	31.40	-0.40	1.30		3.1	44.9	42.5	36.0	16.7
MSH-35	35	1.378	32.90		0.15	1.40		1.05	32.30		1.30		3.3	45.9	43.4	37.0	18.1
MSH-36	36	1.417	33.85		0.15	1.40		1.06	33.25		1.30		3.6	48.6	46.1	38.0	18.9
MSH-38	38	1.496	35.80		0.15	1.40		1.10	35.20		1.30		4.0	50.6	48.0	40.0	20.5
MSH-40	40	1.575	37.70		0.15	1.75		1.15	36.75		1.60		5.6	54.0	51.3	52.0	22.6
MSH-42	42	1.654	39.60		0.15	1.75		1.20	38.80		1.60		6.3	56.0	53.2	54.0	24.8
MSH-43	43	1.683	40.50	-0.30	0.15	1.75		1.25	39.65	+0.35	1.60		6.7	57.0	54.0	55.0	26.4
MSH-45	45	1.772	42.40		0.15	1.75	+0.20	1.30	41.60	-0.50	1.60	±0.08	7.0	59.0	55.9	58.0	28.8
MSH-46	46	1.811	43.30		0.15	1.75		1.35	42.55		1.60		7.3	60.0	56.8	59.0	30.4
MSH-48	48	1.890	45.20		0.15	1.75		1.40	44.40		1.60		7.7	62.4	59.1	62.0	33.0
MSH-50	50	1.969	47.20		0.15	1.75		1.40	46.20		1.60		8.2	64.4	61.1	64.0	35.0

\*SIZES -4 THRU -6 STANDARD MATERIAL- CARBON STEEL; OPTIONAL MATERIAL- BERYLLIUM COPPER.

\*\* F.I.M. (FULL INDICATOR MOVEMENT)- MAXIMUM ALLOWABLE DEVIATION OF CONCENTRICITY BETWEEN GROOVE & SHAFT.

† BASED ON HOUSINGS/SHAFTS MADE OF COLD ROLLED STEEL.

FOR AN EXPLANATION OF FORMULAS USED TO DERIVE THRUST LOAD AND OTHER PERFORMANCE DATA CONTACT THE ROTOR CLIP ENGINEERING DEPARTMENT.

\*\*\*FOR PLATED RINGS ADD 0.05 TO THE LISTED MAXIMUM THICKNESS (T) AND BEVELED END THICKNESS (U) VALUES.

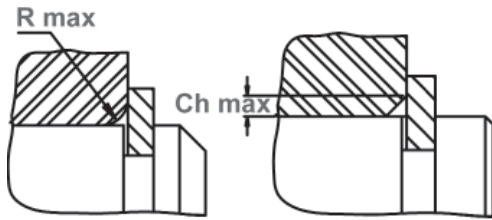

Allowable Corner Radius & Chamfer

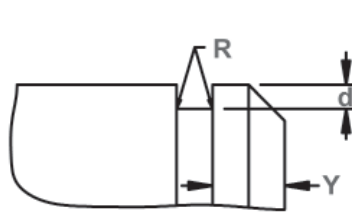

Exploded Groove Profile & Edge Margin (Y)  
 Maximum bottom radii (R), 0.10 for ring sizes  
 -7 thru -18; 0.2 for ring sizes -19 thru -30;  
 0.3 for ring sizes -32 thru -50  
 0.4 for ring sizes -52 thru -100



Alternate Lug Design  
 For Sizes  
 MSH-4 Thru MSH-6



Alternate Design  
 (Manufacturer's Option)

RING NO.	LUG HEIGHT	MAXIMUM SECTION	MINIMUM SECTION	HOLE DIAMETER	GAGING DIA.	ALLOWABLE CORNER RADII & CHAMFERS		MAX. LOAD w/ R max or Ch max (kN)	EDGE MARGIN	R.P.M. LIMITS Standard Material
	H nom	S max/Ref.	S min/Ref.	R min	Gd	R max	Ch max	P'r	Y	RPM
MSH-4*	1.35	0.65	0.40	0.6	4.90	0.35	0.25	0.2	0.3	70000
MSH-5*	1.40	0.65	0.40	0.6	5.85	0.35	0.25	0.5	0.4	70000
MSH-6*	1.40	0.75	0.50	0.6	6.95	0.35	0.25	0.5	0.5	70000
MSH-7	2.05	0.90	0.60	1.0	8.05	0.45	0.3	2.1	0.6	60000
MSH-8	2.20	1.00	0.65	1.0	9.15	0.5	0.35	2.1	0.8	55000
MSH-9	2.20	1.15	0.75	1.0	10.35	0.6	0.35	2.1	0.8	48000
MSH-10	2.20	1.30	0.80	1.0	11.50	0.7	0.4	2.1	0.9	42000
MSH-11	2.20	1.40	0.85	1.0	12.60	0.75	0.45	2.1	1.0	38000
MSH-12	2.20	1.50	0.90	1.0	13.80	0.8	0.45	2.1	1.0	34000
MSH-13	2.80	1.60	0.95	1.2	15.05	0.8	0.5	4.0	1.0	31000
MSH-14	2.80	1.70	1.00	1.2	15.60	0.9	0.5	4.0	1.2	28000
MSH-15	2.80	1.80	1.05	1.2	17.20	1.0	0.6	4.0	1.3	27000
MSH-16	2.80	2.05	1.15	1.2	18.35	1.1	0.6	4.0	1.4	25000
MSH-17	2.80	2.10	1.15	1.2	19.35	1.1	0.6	4.0	1.4	24000
MSH-18	3.45	2.25	1.25	1.3	20.60	1.2	0.7	6.0	1.5	23000
MSH-19	3.45	2.35	1.30	1.3	21.70	1.2	0.7	6.0	1.6	21500
MSH-20	3.45	2.40	1.35	1.3	22.65	1.2	0.7	6.0	1.7	20000
MSH-21	3.45	2.50	1.40	1.3	23.80	1.3	0.7	6.0	1.8	19000
MSH-22	3.45	2.70	1.50	1.3	24.90	1.3	0.8	6.0	1.9	18500
MSH-23	3.45	2.80	1.60	1.3	26.00	1.3	0.8	6.0	2.0	18000
MSH-24	4.20	2.90	1.60	1.9	27.15	1.4	0.8	6.0	2.1	17500
MSH-25	4.20	2.90	1.70	1.9	28.10	1.4	0.8	6.0	2.3	17000
MSH-26	4.20	3.00	1.70	1.9	29.25	1.5	0.9	6.0	2.3	16500
MSH-27	4.60	3.10	1.80	1.9	30.35	1.5	0.9	8.6	2.3	16300
MSH-28	4.60	3.20	1.80	1.9	31.45	1.6	1.0	8.6	2.4	15800
MSH-30	4.60	3.30	1.80	1.9	33.60	1.6	1.0	8.6	2.5	15000
MSH-32	4.60	3.60	1.90	1.9	35.90	1.7	1.0	8.6	2.7	14800
MSH-34	4.60	3.80	2.00	1.9	37.90	1.7	1.1	8.6	3.0	14000
MSH-35	4.60	3.90	2.10	1.9	39.00	1.8	1.1	8.6	3.1	13500
MSH-36	5.40	4.10	2.20	1.9	40.20	1.9	1.2	8.6	3.2	13300
MSH-38	5.40	4.30	2.30	3.1	42.50	2.0	1.2	8.6	3.3	12700
MSH-40	6.00	4.40	2.30	3.1	44.50	2.1	1.2	13.2	3.4	12000
MSH-42	6.00	4.60	2.40	3.1	46.90	2.2	1.3	13.2	3.6	11000
MSH-43	6.00	4.70	2.50	3.1	47.90	2.3	1.4	13.2	3.8	10800
MSH-45	6.00	4.80	2.60	3.1	50.00	2.3	1.4	13.2	3.9	10000
MSH-46	6.00	4.90	2.60	3.1	50.90	2.4	1.4	13.2	4.0	9500
MSH-48	6.20	5.00	2.60	3.1	53.00	2.4	1.4	13.2	4.2	8800
MSH-50	6.20	5.10	2.70	3.1	55.20	2.4	1.4	13.2	4.2	8000

FOR HARDNESS SPECIFICATIONS SEE END OF THE SECTION.





# MSH Shaft Rings

## Axially Assembled, External, ANSI Metric

Once installed in the groove of a shaft, the portion of the ring protruding from the groove (also called a "shoulder") holds an assembly in place.

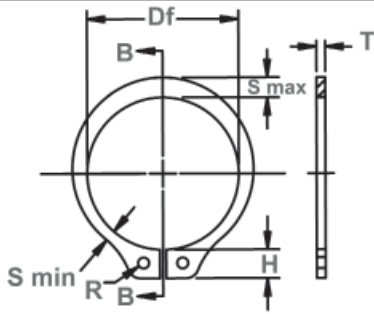

Free Diameter & Ring Measurements with Section B-B

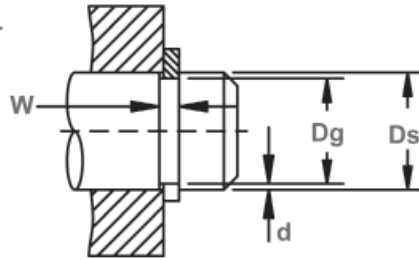

Shaft Diameter & Groove Dimensions

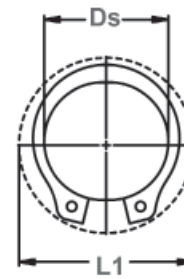

Clearance Diameter Expanded Over Shaft



Clearance Diameter & Gaging Diameter Released in Groove.

RING NO.	SHAFT DIAMETER		GROOVE SIZE						RING SIZE & WEIGHT				CLEARANCE DIA.		i THRUST LD (kN)		
			DIAMETER			WIDTH		DEPTH	FREE DIAMETER	THICKNESS ***		Wt. Per 1000 pcs.	Expanded over Shaft	Released in Groove	Sqr. corner abutment		
	Ds mm	Ds INCH	Dg	tol	F.I.M.**	W	tol	d	Df	tol	T	tol	kg	L1	L2	Pr	Pg
MSH-54	54	2.126	51.00	-0.30	0.15	2.15		1.50	49.90		2.00		11.8	69.6	66.1	87.0	40.0
MSH-55	55	2.165	51.80		0.15	2.15		1.60	50.60		2.00		11.9	70.6	66.9	89.0	44.0
MSH-57	57	2.244	53.80		0.20	2.15		1.60	52.90	+0.35	2.00		12.5	72.6	68.9	91.0	45.0
MSH-58	58	2.283	54.70		0.20	2.15		1.65	53.60	-0.65	2.00		12.6	73.6	69.8	93.0	46.0
MSH-60	60	2.362	56.70		0.20	2.15		1.65	55.80		2.00		13.2	75.6	71.8	97.0	49.0
MSH-62	62	2.441	58.60		0.20	2.15		1.70	57.30		2.00		13.4	77.6	73.6	100.0	52.0
MSH-65	65	2.559	61.60		0.20	2.15		1.70	60.40		2.00		15.4	80.6	76.6	105.0	54.0
MSH-68	68	2.677	64.50		0.20	2.15		1.75	63.10		2.00		16.3	83.6	79.5	110.0	58.0
MSH-70	70	2.756	66.40		0.20	2.55	+0.20	1.80	64.60		2.40	±0.08	19.3	88.1	83.9	136.0	62.0
MSH-72	72	2.835	68.30	-0.40	0.20	2.55		1.85	66.60		2.40		20.6	90.1	85.8	140.0	65.0
MSH-75	75	2.953	71.20		0.20	2.55		1.90	69.00		2.40		22.6	93.1	88.7	147.0	69.0
MSH-78	78	3.071	74.00		0.20	2.55		2.00	72.00	+0.50	2.40		21.5	95.4	92.1	151.0	76.0
MSH-80	80	3.150	75.90		0.20	2.55		2.05	74.20	-0.75	2.40		26.8	97.9	93.1	155.0	80.0
MSH-82	82	3.228	77.80		0.20	2.55		2.10	76.40		2.40		28.1	100.0	95.1	159.0	84.0
MSH-85	85	3.346	80.60		0.20	2.55		2.20	78.60		2.40		29.0	103.0	97.9	165.0	91.0
MSH-88	88	3.464	83.50		0.20	2.95		2.25	81.40		2.80		32.2	107.0	100.8	199.0	97.0
MSH-90	90	3.543	85.40		0.20	2.95		2.30	83.20		2.80		33.1	109.0	103.6	204.0	101.0
MSH-95	95	3.740	90.20		0.20	2.95		2.40	88.10		2.80		37.6	114.0	108.6	215.0	112.0
MSH-100	100	3.852	95.20		0.20	2.95		2.42	92.50		2.80		43.1	119.5	113.7	227.0	123.0

\*\* F.I.M. (FULL INDICATOR MOVEMENT)- MAXIMUM ALLOWABLE DEVIATION OF CONCENTRICITY BETWEEN GROOVE & SHAFT.

i BASED ON HOUSINGS/SHAFTS MADE OF COLD ROLLED STEEL.

FOR AN EXPLANATION OF FORMULAS USED TO DERIVE THRUST LOAD AND OTHER PERFORMANCE DATA CONTACT THE ROTOR CLIP ENGINEERING DEPARTMENT.

\*\*\*FOR PLATED RINGS ADD 0.05 TO THE LISTED MAXIMUM THICKNESS (T) AND BEVELED END THICKNESS (U) VALUES.

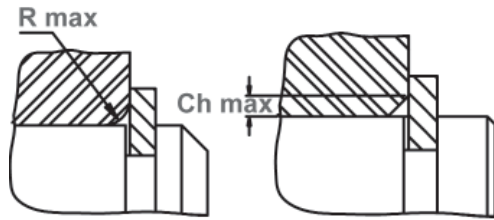

Allowable Corner Radius & Chamfer

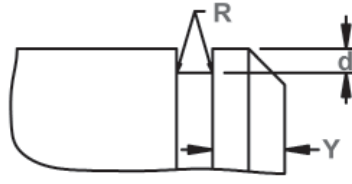

Exploded Groove Profile & Edge Margin (Y)  
 Maximum bottom radii (R), 0.10 for ring sizes  
 -7 thru -18; 0.2 for ring sizes -19 thru -30;  
 0.3 for ring sizes -32 thru -50  
 0.4 for ring sizes -52 thru -100



Alternate Lug Design  
 For Sizes  
 MSH-4 Thru MSH-6

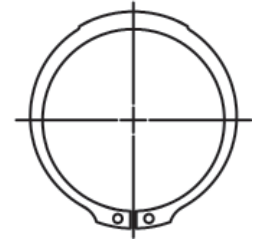

Alternate Design  
 (Manufacturer's Option)

RING NO.	LUG HEIGHT	MAXIMUM SECTION	MINIMUM SECTION	HOLE DIAMETER	GAGING DIA.	ALLOWABLE CORNER RADII & CHAMFERS		MAX. LOAD w/ R max or Ch max (kN)	EDGE MARGIN	R.P.M. LIMITS Standard Material
	H nom	S max/Ref.	S min/Ref.	R min	Gd	R max	Ch max	P'r	Y	RPM
MSH-54	6.80	5.40	2.90	3.1	59.50	2.5	1.5	22.0	4.5	7500
MSH-55	6.80	5.40	2.90	3.1	60.40	2.5	1.5	22.0	4.8	7400
MSH-57	6.80	5.60	3.00	3.1	62.70	2.6	1.5	22.0	4.8	7200
MSH-58	6.80	5.60	3.00	3.1	63.60	2.6	1.6	22.0	4.9	7100
MSH-60	6.80	5.70	3.00	3.1	65.80	2.6	1.6	22.0	4.9	7000
MSH-62	6.80	5.80	3.00	3.1	67.90	2.7	1.6	22.0	5.1	6900
MSH-65	6.80	6.00	3.10	3.1	71.20	2.8	1.7	22.0	5.1	6700
MSH-68	6.80	6.20	3.30	3.1	74.50	2.9	1.7	22.0	5.3	6500
MSH-70	7.80	6.30	3.30	3.1	76.40	2.9	1.7	32.0	5.4	6400
MSH-72	7.80	6.40	3.30	3.1	78.50	2.9	1.7	32.0	5.5	6200
MSH-75	7.80	6.60	3.40	3.1	81.70	3.0	1.8	32.0	5.7	5900
MSH-78	7.80	6.60	3.40	3.1	84.60	3.0	1.8	32.0	6.0	5600
MSH-80	7.80	7.00	3.60	3.1	87.00	3.1	1.9	32.0	6.1	5400
MSH-82	7.80	7.10	3.70	3.1	89.00	3.2	1.9	32.0	6.3	5200
MSH-85	7.80	7.30	3.80	3.1	92.10	3.2	1.9	32.0	6.6	5000
MSH-88	8.40	7.50	3.90	3.1	95.10	3.2	1.9	47.0	6.7	4800
MSH-90	8.40	7.50	3.90	3.1	97.10	3.2	1.9	47.0	6.9	4500
MSH-95	8.40	7.90	4.10	3.1	102.70	3.4	2.1	47.0	7.2	4350
MSH-100	8.70	8.00	4.10	3.1	108.00	3.5	2.1	47.0	7.5	4150

HARDNESS RANGES: STAINLESS STEEL RINGS (PH 15-7MO)

RING TYPE	SIZE RANGE	SCALE	ROCKWELL HARDNESS
MSH	7-21	30N	63-69.5
	22-100	C	44-51

HARDNESS RANGES: CARBON STEEL RINGS (SAE 1060-1090)

RING TYPE	SIZE RANGE	SCALE	ROCKWELL HARDNESS
MSH	4-6	15N	86-88
	7-12	30N	69.5-73
	13-21	30N	67.5-71
	22-26	C	49-53
	27-85	C	48-52
	88-100	C	47-51





# MSR Shaft Rings

## Axially Assembled, External Reinforced, ANSI Metric

The MSR is an extra thick version of a regular MSH retaining ring. As such, it is stronger and can withstand greater thrust loads than its standard counterpart.

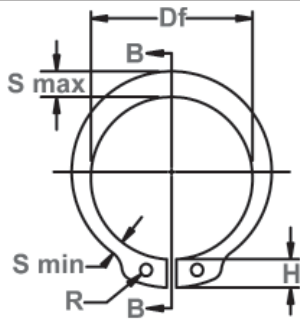

Free Diameter & Ring Measurements With Section B-B

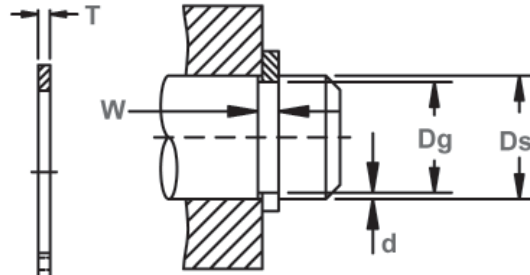

Shaft Diameter & Groove Dimensions

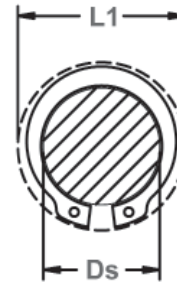

Clearance Diameter Expanded Over Shaft

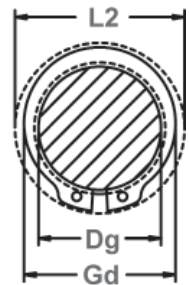

Clearance Diameter & Gaging Diameter Released In Groove

RING NO.	SHAFT DIAMETER		GROOVE SIZE						RING SIZE & WEIGHT				CLEARANCE DIA.			THRUST LD (kN.)	
			DIAMETER			WIDTH		DEPTH	FREE DIAMETER		THICKNESS***		Wt. Per 1000 pcs.	Expanded over Shaft	Re-released in Groove	Sqr. corner abutment	
	Ds mm	Ds INCH	Dg	tol	F.I.M.*	W	tol	d	Df	tol	T	tol				kg	L1
MSR-10	10	0.393	9.40	-0.08	0.05	1.00	+0.15	0.30	9.20	+0.08	0.9	±0.06	0.32	15.6	14.8	9.3	2.9
MSR-11	11	0.433	10.30		0.05	1.00		0.35	10.00	-0.20	0.9		0.39	16.6	15.8	10.8	3.8
MSR-12	12	0.472	11.30		0.05	1.20		0.35	11.05	1.1	0.63		17.6	16.8	13.7	4.0	
MSR-13	13	0.512	12.20	-0.10	0.05	1.40	+0.15	0.40	11.80	+0.13	1.3	±0.06	0.72	19.5	18.5	17.6	5.0
MSR-14	14	0.551	13.15		0.05	1.40		0.43	12.80		1.3		0.80	20.5	19.5	18.9	5.8
MSR-15	15	0.591	14.10		0.05	1.40		0.45	13.80		1.3		1.00	22.1	21.1	20.3	6.5
MSR-16	16	0.630	15.00	-0.10	0.08	1.40	+0.15	0.50	14.70	-0.25	1.3	±0.06	1.04	23.2	22.0	21.6	7.7
MSR-17	17	0.669	15.95		0.08	1.40		0.53	15.65		1.3		1.2	24.2	22.9	23.0	8.7
MSR-18	18	0.708	16.85		0.08	1.75		0.58	16.55		1.6		1.9	26.8	25.5	30.0	10.0
MSR-19	19	0.748	17.80	-0.15	0.08	2.15	+0.20	0.60	17.50	+0.25	2.0	±0.08	2.5	28.8	27.4	40.0	11.0
MSR-20	20	0.787	18.75		0.08	2.15		0.63	18.45		2.0		2.8	29.8	28.4	42.0	13.1
MSR-22	22	0.866	20.70		0.08	2.15		0.65	20.40		2.0		3.4	31.9	30.4	46.0	13.7
MSR-25	25	0.984	23.50	-0.15	0.08	2.15	+0.20	0.75	23.10	-0.40	2.0	±0.08	3.5	34.9	33.1	52.0	18.0
MSR-27	27	1.063	25.40		0.10	2.55		0.80	24.85		2.4		5.2	39.0	37.1	67.0	20.8
MSR-28	28	1.102	26.30		0.10	2.55		0.85	25.70		2.4		5.6	40.0	38.0	69.0	22.8
MSR-30	30	1.181	28.20	-0.15	0.10	2.55	+0.20	0.90	27.60	+0.25	2.4	±0.08	6.1	42.0	40.0	74.0	26.0
MSR-32	32	1.260	30.00		0.10	2.55		1.00	29.35		2.4		6.8	44.1	41.8	79.0	30.8
MSR-35	35	1.378	32.80		0.10	2.55		1.10	32.20		2.4		8.1	47.1	44.6	87.0	38.0
MSR-38	38	1.496	35.60	-0.20	0.10	2.95	+0.25	1.20	35.05	-0.50	2.8	±0.10	12.2	53.2	50.5	111.0	44.0
MSR-40	40	1.575	37.50		0.15	2.95		1.25	36.70		2.8		14.1	55.2	52.4	116.0	48.0
MSR-45	45	1.772	42.20		0.15	2.95		1.40	41.10		2.8		15.1	60.9	57.7	130.0	61.0
MSR-50	50	1.969	47.00	-0.20	0.15	3.40	+0.25	1.50	45.50	-0.50	3.2	±0.10	21.8	67.1	63.8	165.0	72.0

\* F.I.M.(FULL INDICATOR MOVEMENT)-MAXIMUM ALLOWABLE DEVIATION OF CONCENTRICITY BETWEEN GROOVE AND SHAFT.

† BASED ON HOUSINGS/SHAFTS MADE OF COLD ROLLED STEEL. FOR AN EXPLANATION OF FORMULAS USED TO DERIVE THRUST LOAD AND OTHER PERFORMANCE DATA, CONTACT THE ROTOR CLIP ENGINEERING DEPARTMENT.

\*\*\* FOR PLATED RINGS, ADD 0.05 TO THE LISTED MAXIMUM THICKNESS. MAXIMUM RING THICKNESS WILL BE A MINIMUM OF 0.005 LESS THAN THE LISTED GROOVE WIDTH (W) MINIMUM.



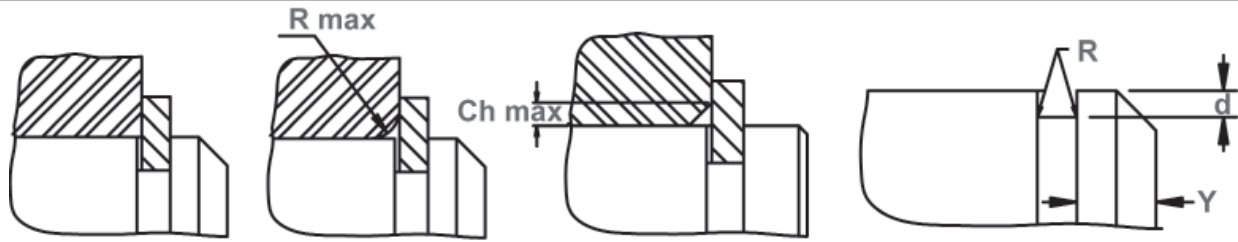

Square Corner Abutment

Allowable Corner Radius & Chamfer

Exploded Groove Profile & Edge Margin (Y)  
 Maximum bottom radii (R), 0.10 for ring sizes  
 -10 thru -15; 0.15 for ring sizes -16 thru -20;  
 0.20 for ring sizes -22 thru -30  
 0.30 for ring sizes -32 thru -50

RING NO.	LUG HEIGHT	MAXIMUM SECTION	MINIMUM SECTION	HOLE DIAMETER	GAGING DIA.	ALLOWABLE CORNER RADII & CHAMFERS		MAX. LOAD w/ R max or Ch max (kN)	EDGE MARGIN	R.P.M. LIMITS Standard Material
						R max	Ch max			
	H nom	S max	S min	R min	Gd	R max	Ch max	P'r	Y	RPM
MSR-10	2.6	1.7	1.0	1.0	12.15	1.0	0.8	2.7	0.9	66000
MSR-11	2.6	1.9	1.1	1.0	13.40	1.0	0.8	3.0	1.0	60000
MSR-12	2.6	2.2	1.3	1.0	14.95	1.6	1.3	3.2	1.0	55000
MSR-13	3.0	2.3	1.3	1.2	15.80	1.6	1.3	4.6	1.2	52000
MSR-14	3.0	2.4	1.4	1.2	16.90	1.6	1.3	4.8	1.3	47000
MSR-15	3.3	2.6	1.4	1.2	18.20	1.6	1.3	5.2	1.3	42000
MSR-16	3.3	2.7	1.5	1.2	19.20	1.6	1.3	5.4	1.5	39000
MSR-17	3.3	2.8	1.6	1.2	20.45	1.6	1.3	5.7	1.6	36000
MSR-18	4.1	3.0	1.8	1.9	21.75	1.8	1.5	8.0	1.7	35000
MSR-19	4.6	3.2	2.0	1.9	23.05	1.8	1.5	13.2	1.8	30000
MSR-20	4.6	3.4	2.0	1.9	24.30	2.0	1.6	13.2	1.9	29000
MSR-22	4.6	3.8	2.1	1.9	26.60	2.0	1.6	14.7	2.0	27000
MSR-25	4.6	3.8	2.1	1.9	29.45	2.0	1.6	14.7	2.2	24000
MSR-27	5.6	4.1	2.3	2.3	32.00	2.0	1.6	22.9	2.4	22000
MSR-28	5.6	4.3	2.4	2.3	33.20	2.0	1.6	24.0	2.5	20000
MSR-30	5.6	4.5	2.5	2.3	35.40	2.0	1.6	25.0	2.7	19000
MSR-32	5.6	4.7	2.6	2.3	37.30	2.5	2.1	19.0	3.0	18000
MSR-35	5.6	5.1	2.8	2.3	40.80	2.5	2.1	22.0	3.3	16000
MSR-38	7.1	5.5	3.1	2.7	44.40	2.5	2.1	32.0	3.6	15000
MSR-40	7.1	5.8	3.2	2.7	46.70	2.5	2.1	34.0	3.7	13500
MSR-45	7.4	6.5	3.6	2.7	52.20	2.5	2.1	38.0	4.2	12500
MSR-50	8.0	7.1	3.9	3.1	58.40	3.5	2.9	39.0	4.5	11000

LARGER SIZES MAY BE AVAILABLE UPON REQUEST.

HARDNESS RANGES: STAINLESS STEEL RINGS (PH 15-7MO)

RING TYPE	SIZE RANGE	SCALE	ROCKWELL HARDNESS
MSR	10-16	30N	63-69.5
	17-50	C	44-51

HARDNESS RANGES: CARBON STEEL RINGS (SAE 1060-1090)

RING TYPE	SIZE RANGE	SCALE	ROCKWELL HARDNESS
MSR	10-16	30N	68.5-72
	17-50	C	48-52



# ME Shaft Rings

## Radially Assembled, External 'E', ANSI Metric

Perhaps the most popular and widely used radial retaining ring is the "E" (so named because it is shaped like the letter "E").

Three prongs make contact with the bottom of the groove and provide a shoulder for effective retention of assemblies.

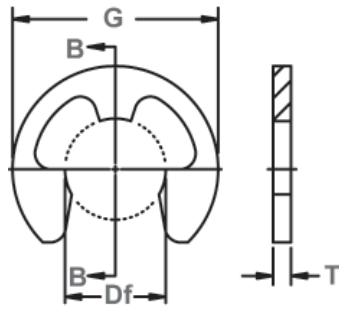

Free Diameter & Ring Measurements  
With Section B-B

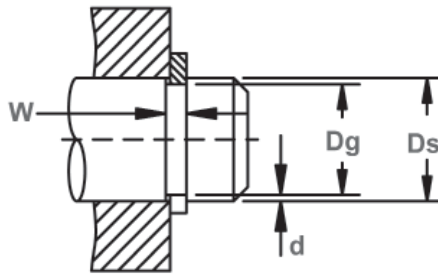

Shaft Diameter &  
Groove Dimensions

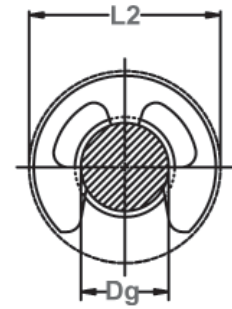

Clearance Diameter &  
Installed In Groove

RING NO.	SHAFT DIAMETER		GROOVE SIZE					RING SIZE & WEIGHT					CLEARANCE DIA.			i THRUST LD (kN)	
	Ds mm	Ds DEC	DIAMETER		WIDTH	DEPTH	FREE DIAMETER		THICKNESS***	Wt. Per 1000 Pcs.	Free Out-Side Dia. Ref.	Re-leased In Groove	Sqr. Corner Abutment				
			Dg	Tol.	F.I.M.**		W	Tol.					d	Df	Tol.	T	Tol.
ME-1*	1	.039	0.72	-0.05	0.04	0.32	+0.05	0.14	0.64		0.25	±0.05	0.004	2.0	2.2	0.06	0.02
ME-2	2	.079	1.45		0.04	0.32		0.28	1.30		0.25		0.014	4.0	4.3	0.13	0.09
ME-3	3	.118	2.30		0.04	0.50	+0.10	0.35	2.10	+0.03	0.40		0.036	5.6	6.0	0.30	0.17
ME-4	4	.157	3.10	-0.08	0.05	0.70		0.45	2.90	-0.08	0.60		0.095	7.2	7.6	0.70	0.30
ME-5	5	.197	3.90		0.05	0.70		0.55	3.70		0.60		0.13	8.5	8.9	0.90	0.40
ME-6	6	.236	4.85		0.05	0.70		0.58	4.70		0.60		0.21	11.1	11.5	1.10	0.60
ME-7	7	.275	5.55		0.08	0.70		0.73	5.25		0.60		0.34	13.4	14.0	1.20	0.80
ME-8	8	.315	6.40		0.08	0.70		0.80	6.15		0.60		0.35	14.6	15.1	1.40	1.00
ME-9	9	.354	7.20	-0.10	0.08	1.00		0.90	6.80		0.90	±0.06	0.58	15.8	16.5	3.00	1.30
ME-10	10	.393	8.00		0.08	1.00	+0.15	1.00	7.60	+0.05	0.90		0.68	16.8	17.5	3.40	1.60
ME-11	11	.433	8.90		0.10	1.00		1.05	8.55	-0.10	0.90		0.68	17.4	18.0	3.70	1.90
ME-12	12	.472	9.60		0.10	1.20		1.20	9.20		1.10		1.00	18.6	19.3	4.90	2.30
ME-13	13	.512	10.30		0.10	1.20		1.35	9.95		1.10		1.13	20.3	21.0	5.40	2.90
ME-15	15	.591	11.80	-0.15	0.10	1.20		1.60	11.40		1.10		1.40	22.8	23.5	6.20	4.00
ME-16	16	.630	12.50		0.10	1.20		1.75	12.15		1.10		1.45	23.8	24.5	6.60	4.50
ME-18	18	.709	14.30		0.10	1.40		1.85	13.90	+0.10	1.30		2.3	27.2	27.9	8.70	5.40
ME-20	20	.787	16.00		0.10	1.40		2.00	15.60	-0.15	1.30		2.8	30.0	30.7	9.80	6.50
ME-22	22	.866	17.40	-0.20	0.10	1.40		2.30	17.00		1.30		3.4	33.0	33.7	10.80	8.10
ME-25	25	.984	20.00		0.10	1.40		2.50	19.50		1.30		4.2	37.1	37.9	12.20	10.10

\* AVAILABLE IN BERYLLIUM COPPER ONLY.

\*\* F.I.M. (FULL INDICATOR MOVEMENT)- MAXIMUM ALLOWABLE DEVIATION OF CONCENTRICITY BETWEEN GROOVE AND SHAFT.

i BASED ON GROOVES MADE OF COLD ROLLED STEEL. FOR AN EXPLANATION OF FORMULAS USED TO DERIVE THRUST LOAD AND OTHER PERFORMANCE DATA CONTACT THE ROTOR CLIP ENGINEERING DEPARTMENT.

\*\*\* FOR PLATED RINGS, ADD 0.05 TO THE LISTED MAXIMUM THICKNESS. MAXIMUM THICKNESS WILL BE A MINIMUM OF 0.005 LESS THAN THE LISTED GROOVE WIDTH (W) MINIMUM.

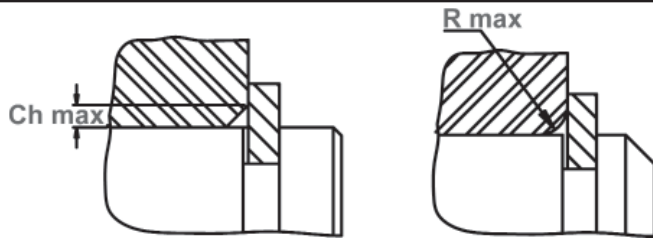

Maximum Corner Radius & Chamfer

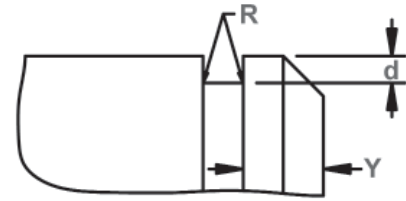

Exploded Groove Profile & Edge Margin (Y)  
 Maximum bottom radii (R), 0.05 for ring sizes  
 -1 thru -2; 0.15 for ring sizes -3 thru -7;  
 0.25 for ring sizes -8 thru -13  
 0.40 for ring sizes -15 thru -25

RING NO.	ALLOWABLE CORNER RADII & CHAMFERS		MAX. LOAD w/ R max or Ch max (kN)	EDGE MARGIN	R.P.M. LIMITS Standard Material
	R max	Ch max			
ME-1*	0.4	0.25	0.06	0.3	40000
ME-2	0.8	0.50	0.13	0.6	40000
ME-3	1.1	0.70	0.30	0.7	34000
ME-4	1.6	1.20	0.70	0.9	31000
ME-5	1.6	1.20	0.90	1.1	27000
ME-6	1.6	1.20	1.10	1.2	25000
ME-7	1.6	1.20	1.20	1.5	23000
ME-8	1.7	1.30	1.40	1.6	21500
ME-9	1.7	1.30	3.00	1.8	19500
ME-10	1.7	1.30	3.40	2.0	18000
ME-11	1.7	1.30	3.70	2.1	16500
ME-12	1.9	1.40	4.90	2.4	15000
ME-13	2.0	1.50	5.40	2.7	13000
ME-15	2.0	1.50	6.20	3.2	11500
ME-16	2.0	1.50	6.60	3.5	10000
ME-18	2.1	1.60	8.70	3.7	9000
ME-20	2.2	1.70	9.80	4.0	8000
ME-22	2.2	1.70	10.80	4.6	7000
ME-25	2.4	1.90	12.20	5.0	5000

LARGER SIZES MAY BE AVAILABLE UPON REQUEST.

HARDNESS RANGES: STAINLESS STEEL RINGS (PH 15-7MO)

RING TYPE	SIZE RANGE	SCALE	ROCKWELL HARDNESS
ME	2-3	15N	82.5-86*
	4-8	30N	63-69.5
	9-25	C	44-51

HARDNESS RANGES: BERYLLIUM COPPER RINGS

RING TYPE	SIZE RANGE	SCALE	ROCKWELL HARDNESS
ME	1-3	15N	79-82*
	4-9	30N	56.5-68
	10-25	C	37-43

HARDNESS RANGES: CARBON STEEL RINGS (SAE 1060-1090)

RING TYPE	SIZE RANGE	SCALE	ROCKWELL HARDNESS
ME	2-3	15N	85-87*
	4-8	30N	67.5-71
	9-25	C	48-52

\*HARDNESS CAN NOT BE CHECKED WITH ANY DEGREE OF ACCURACY DIRECTLY ON THESE RINGS.



# MC Shaft Rings

## Radially Assembled, External Crescent, ANSI Metric

Ideal for low clearance applications where radial installation is preferred.

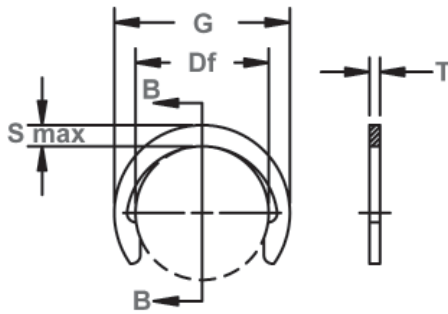

Free Diameter & Ring Measurements  
With Section B-B

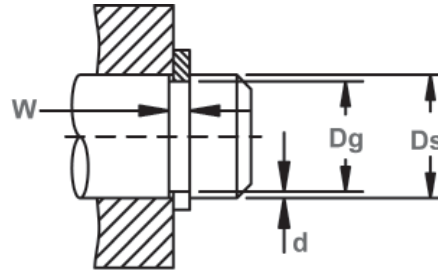

Shaft Diameter &  
Groove Dimensions

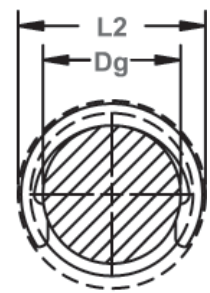

Clearance Diameter  
Installed In Groove

RING NO.	SHAFT DIAMETER		GROOVE SIZE						RING SIZE & WEIGHT				CLEARANCE DIA.			THRUST LD (kN)	
			DIAMETER			WIDTH		DEPTH	FREE DIAMETER		THICKNESS***		Wt. Per 1000 Pcs.	Free Outside Dia. Ref.	Re-leased In Groove	Sqr. Corner Abutment	
	Ds mm	Ds DEC	Dg	Tol.	F.I.M.*	W	Tol.	d	Df	Tol.	T	Tol.				kg	G
MC-3	3	0.118	2.3	-0.05	0.04	0.5	+0.10	0.35	2.18	±0.06	0.4		0.019	3.98	4.3	0.4	0.2
MC-4	4	0.157	3.2		0.04	0.5		0.40	3.00		0.4		0.025	5.00	5.4	0.5	0.4
MC-5	5	0.197	4.0	-0.07	0.06	0.7		0.50	3.80		0.6		0.055	6.20	6.6	0.9	0.6
MC-6	6	0.236	5.0		0.06	0.7		0.50	4.80	±0.08	0.6		0.072	7.40	7.8	1.1	0.7
MC-7	7	0.276	6.0		0.06	0.7		0.50	5.80		0.6		0.090	8.60	9.0	1.3	0.8
MC-8	8	0.315	7.0		0.06	0.7		0.50	6.80		0.6		0.12	10.00	10.4	1.5	1.0
MC-9	9	0.354	8.0		0.06	0.7		0.50	7.80	±0.09	0.6		0.13	11.20	11.6	2.2	1.1
MC-10	10	0.393	9.0		0.06	0.7		0.50	8.75		0.6		0.15	12.15	12.6	2.3	1.2
MC-11	11	0.433	10.0	-0.10	0.10	0.7		0.50	9.65		0.6		0.17	13.20	13.8	2.6	1.3
MC-12	12	0.472	10.9		0.10	0.7		0.55	10.55		0.6		0.20	14.35	15.0	2.8	1.6
MC-13	13	0.512	11.8		0.10	1.1	+0.15	0.60	11.40		1.0	±0.06	0.39	15.40	16.1	4.9	1.9
MC-14	14	0.551	12.7		0.10	1.1		0.65	12.30		1.0		0.42	16.30	17.0	5.5	2.1
MC-15	15	0.591	13.6		0.10	1.1		0.70	13.20	±0.18	1.0		0.50	17.40	18.1	6.0	2.5
MC-16	16	0.630	14.5		0.10	1.1		0.75	14.10		1.0		0.51	18.50	19.2	6.3	2.9
MC-17	17	0.669	15.4		0.10	1.1		0.80	14.90		1.0		0.55	19.40	20.2	6.7	3.3
MC-18	18	0.708	16.3		0.10	1.3		0.85	15.80		1.2		0.67	20.40	21.3	8.5	3.6
MC-19	19	0.748	17.2		0.15	1.3		0.90	16.70		1.2		0.85	21.50	22.4	9.0	4.2
MC-20	20	0.787	18.1		0.15	1.3		0.95	17.55		1.2		0.85	22.65	23.6	9.5	4.6
MC-22	22	0.866	19.9		0.15	1.3		1.05	19.40		1.2		1.07	25.00	25.9	10.4	5.6
MC-23	23	0.905	20.8		0.15	1.3		1.10	20.20		1.2		1.15	26.00	27.0	10.9	6.1
MC-24	24	0.945	21.7		0.15	1.3		1.15	21.10		1.2		1.2	27.10	28.1	11.3	6.7
MC-25	25	0.984	22.6	-0.20	0.15	1.3		1.20	22.00	±0.21	1.2		1.4	28.30	29.3	11.8	7.4
MC-26	26	1.023	23.5		0.15	1.3		1.25	22.90		1.2		1.5	29.40	30.4	12.2	7.8
MC-28	28	1.062	25.2		0.15	1.75		1.40	24.60		1.6		2.5	31.60	32.6	17.6	9.5
MC-30	30	1.181	27.0		0.15	1.75		1.50	26.30		1.6		2.6	33.70	34.9	19.2	10.8
MC-32	32	1.260	28.8		0.15	1.75		1.60	28.10		1.6		3.2	36.10	37.3	20.5	12.2
MC-35	35	1.378	31.5		0.15	1.75		1.75	30.80		1.6		3.5	39.40	40.6	22.4	14.7
MC-36	36	1.417	32.4		0.20	1.75		1.80	31.70	±0.25	1.6		4.1	40.50	41.7	23.1	15.7
MC-38	38	1.496	34.2		0.20	1.75		1.90	33.40		1.6		4.3	42.60	43.9	23.8	17.2
MC-40	40	1.575	36.0		0.20	1.75	+0.20	2.00	35.20		1.6	±0.08	4.7	45.00	46.3	25.6	19.6
MC-42	42	1.654	37.8	-0.25	0.20	1.75		2.10	37.00		1.6		5.0	47.20	48.5	27.5	21.0
MC-45	45	1.772	40.5		0.20	1.75		2.25	39.60		1.6		5.4	50.60	52.1	28.4	24.5
MC-48	48	1.890	43.2		0.20	1.75		2.40	42.30	±0.39	1.6		7.1	54.10	55.6	29.9	27.5
MC-50	50	1.969	45.0		0.20	2.15		2.50	44.00		2.0		8.9	56.40	58.0	40.0	30.4
MC-52	52	2.047	47.0		0.20	2.15		2.50	46.00		2.0		9.3	58.60	60.3	41.0	31.3
MC-55	55	2.165	50.0		0.20	2.15		2.50	48.50		2.0		10.4	61.50	63.7	43.0	33.3

\*F.I.M.(FULL INDICATOR MOVEMENT)-MAXIMUM ALLOWABLE DEVIATION OF CONCENTRICITY BETWEEN GROOVE AND SHAFT.

† BASED ON HOUSINGS/SHAFTS MADE OF COLD ROLLED STEEL. FOR AN EXPLANATION OF FORMULAS USED TO DERIVE THRUST LOAD AND OTHER PERFORMANCE DATA, CONTACT THE ROTOR CLIP ENGINEERING DEPT.

\*\*\* FOR PLATED RINGS ADD 0.05 TO THE LISTED MAXIMUM THICKNESS. MAXIMUM RING THICKNESS WILL BE A MINIMUM OF 0.005 LESS THAN THE LISTED GROOVE WIDTH (W) MINIMUM.

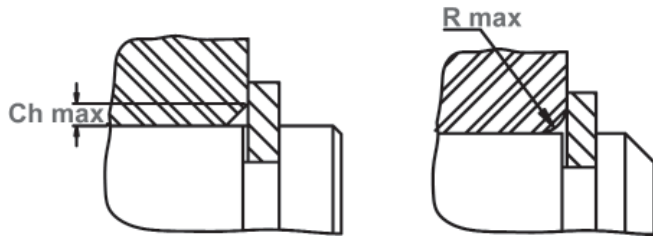

Maximum Corner Radius & Chamfer

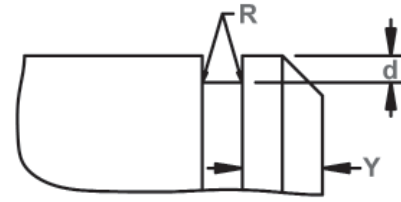

Exploded Groove Profile & Edge Margin (Y)  
 Maximum bottom radii (R), 0.10 for ring sizes  
 -3 thru -4; 0.20 for ring sizes -5 thru -16;  
 0.30 for ring sizes -17 thru -30  
 0.40 for ring sizes -32 thru -55

RING NO.	MAXIMUM SECTION	ALLOWABLE CORNER RADII & CHAMFERS		MAX. LOAD w/ R max or Ch max (kN)	EDGE MARGIN	R.P.M.
		Smax/Ref.	R max			
MC-3	0.90	0.4	0.30	0.4	1.0	80000
MC-4	1.00	0.4	0.30	0.4	1.2	80000
MC-5	1.20	0.6	0.45	0.7	1.5	80000
MC-6	1.30	0.6	0.45	0.7	1.5	80000
MC-7	1.40	0.6	0.45	0.7	1.5	69000
MC-8	1.60	0.6	0.45	0.7	1.5	67000
MC-9	1.70	0.6	0.45	0.7	1.5	58000
MC-10	1.70	0.6	0.45	0.7	1.5	50000
MC-11	1.80	0.6	0.45	0.7	1.5	40000
MC-12	1.90	0.6	0.45	0.7	1.7	35000
MC-13	2.00	1.0	0.8	2.0	1.8	30000
MC-14	2.00	1.0	0.8	2.0	2.0	27000
MC-15	2.10	1.0	0.8	2.0	2.1	25000
MC-16	2.20	1.0	0.8	2.0	2.3	24000
MC-17	2.25	1.0	0.8	2.0	2.4	23000
MC-18	2.30	1.2	0.9	2.8	2.6	21000
MC-19	2.40	1.2	0.9	2.8	2.7	20500
MC-20	2.55	1.2	0.9	3.0	2.9	20000
MC-22	2.80	1.2	0.9	3.0	3.2	16500
MC-23	2.90	1.2	0.9	3.2	3.3	15200
MC-24	3.00	1.2	0.9	3.2	3.5	15100
MC-25	3.15	1.2	0.9	3.2	3.6	15000
MC-26	3.25	1.2	0.9	3.2	3.8	14500
MC-28	3.50	1.5	1.15	6.3	4.2	13200
MC-30	3.70	1.5	1.15	6.4	4.5	13000
MC-32	4.00	1.5	1.15	6.6	4.8	12900
MC-35	4.30	1.5	1.15	6.8	5.3	11000
MC-36	4.40	1.5	1.15	6.8	5.4	10200
MC-38	4.60	1.5	1.15	7.1	5.7	9600
MC-40	4.90	1.5	1.15	7.2	6.0	9200
MC-42	5.10	1.5	1.15	7.4	6.3	8600
MC-45	5.50	1.5	1.15	7.6	6.8	8300
MC-48	5.90	1.5	1.15	7.9	7.2	7500
MC-50	6.20	2.0	1.5	12.0	7.5	6800
MC-52	6.30	2.0	1.5	12.0	7.5	6600
MC-55	6.50	2.0	1.5	12.0	7.5	6500

LARGER SIZES MAY BE AVAILABLE UPON REQUEST.

HARDNESS RANGES: STAINLESS STEEL RINGS (PH 15-7MO)

RING TYPE	SIZE RANGE	SCALE	ROCKWELL HARDNESS
MC	3-4	15N	82.5-86
	5-19	30N	63-69.5
	20-55	C	44-51

HARDNESS RANGES: CARBON STEEL RINGS (SAE 1060-1090)

RING TYPE	SIZE RANGE	SCALE	ROCKWELL HARDNESS
MC	3-4	15N	84-86
	5-19	30N	66-69.5
	20-55	C	47-51



# Radially Assembled, External Reinforced 'E', ANSI Metric

# MRE Shaft Rings

The MRE retaining ring is a reinforced version of the ME ring, which will accommodate higher thrust loadings and RPM. MRE rings function in the same size grooves as regular E rings, so that you can change from one to the other without re-engineering the application.

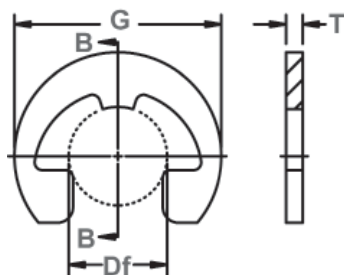

Free Diameter & Ring Measurements  
With Section B-B

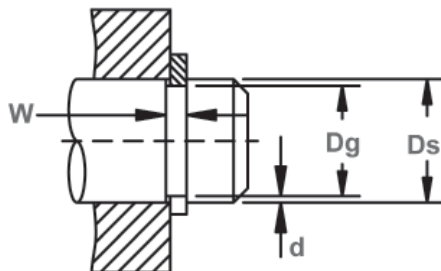

Shaft Diameter &  
Groove Dimensions

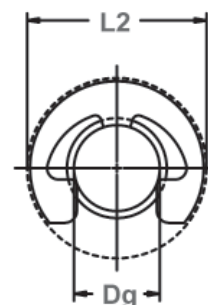

Clearance Diameter  
Installed in Groove

RING NO.	SHAFT DIAMETER		GROOVE SIZE						RING SIZE & WEIGHT				CLEARANCE		I THRUST LD (kN)		
			DIAMETER			WIDTH		DEPTH	FREE DIAMETER		THICKNESS***		Wt. Per 1000 Pcs.	Free Out-Side Dia. Ref.	Re-leased In Groove	Sqr. Corner Abutment	Ring (Safety factor of 3)
	Ds mm	Ds DEC	Dg	Tol.	F.I.M.*	W	Tol.	d	Df	Tol.	T	Tol.					
MRE-4	4	0.157	3.00	-0.05	0.05	0.7	+0.15	0.50	2.90	+0.05-0.08	0.6	±0.06	0.14	8.50	8.9	0.6	0.18
MRE-5	5	0.197	3.85	-0.10	0.05	0.7		0.57	3.65	+0.08	0.6		0.18	9.50	9.9	0.8	0.27
MRE-6	6	0.236	4.85		0.05	0.7	0.57	4.65	-0.08		0.6	0.24	11.35	11.8	1.0	0.34	
MRE-7	7	0.276	5.40	0.08	0.7	0.80	5.20	+0.10		0.6	0.32	13.10	13.7	1.1	0.54		
MRE-8	8	0.315	6.40	0.10	1.0	0.80	6.15		-0.10	0.6	0.36	14.95	15.6	1.3	0.63		
MRE-9	9	0.354	7.10	0.10	1.0	0.95	6.75	+0.10		0.9	0.60	15.70	16.4	2.2	0.80		
MRE-10	10	0.394	7.80	0.10	1.0	1.10	7.45		-0.10	0.9	0.68	16.75	17.5	2.4	1.10		
MRE-11	11	0.433	8.80	0.10	1.0	1.10	8.45	+0.10		0.9	0.86	18.95	19.7	2.7	1.20		
MRE-12	12	0.472	9.50	0.10	1.2	1.25	9.10		-0.10	1.1	1.20	19.60	20.4	3.5	1.50		
MRE-13	13	0.512	10.2	0.10	1.2	1.40	9.80	+0.10		1.1	1.45	20.55	21.3	3.9	1.70		
MRE-14	14	0.551	11.2	0.10	1.2	1.40	10.90		-0.10	1.1	1.60	22.10	22.8	4.2	1.90		
MRE-15	15	0.591	11.8	0.10	1.2	1.60	11.50	+0.10		1.1	1.75	23.20	23.9	4.5	2.30		

\*F.I.M. (FULL INDICATOR MOVEMENT)-MAXIMUM ALLOWABLE DEVIATION OF CONCENTRICITY BETWEEN GROOVE AND SHAFT.

† BASED ON HOUSINGS/SHAFTS MADE OF COLD ROLLED STEEL. FOR AN EXPLANATION OF FORMULAS USED TO DERIVE THRUST LOAD AND OTHER PERFORMANCE DATA, CONTACT THE ROTOR CLIP ENGINEERING DEPT.

\*\*\* FOR PLATED RINGS, ADD 0.05 TO THE LISTED MAXIMUM THICKNESS. MAXIMUM RING THICKNESS WILL BE A MINIMUM OF 0.005 LESS THAN THE LISTED GROOVE WIDTH (W) MINIMUM.

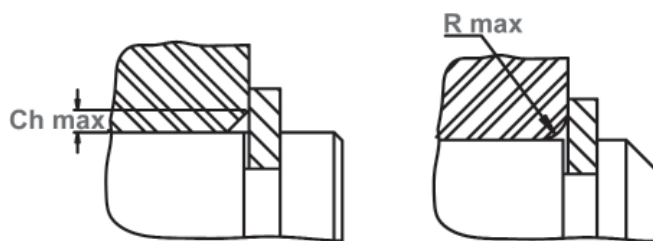

Maximum Corner Radius & Chamfer

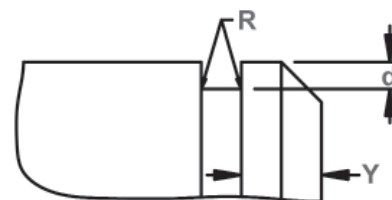

Exploded Groove Profile & Edge Margin (Y)  
 Maximum bottom radii (R), 0.1 for ring sizes -4; 0.15 for ring sizes -5 thru -9; 0.25 for ring sizes -10 thru -15

RING NO.	CORNER RADII & CHAMFERS		LOAD w/ R max or Ch max (kN)	MARGIN	LIMITS Standard Material
	R max	Ch max			
MRE-4	1.6	1.3	0.6	1.0	50000
MRE-5	1.6	1.3	0.8	1.1	43000
MRE-6	1.6	1.3	1.0	1.1	38000
MRE-7	1.6	1.3	1.1	1.6	33000
MRE-8	1.6	1.3	1.3	1.6	28000
MRE-9	1.8	1.4	2.2	1.9	27000
MRE-10	1.8	1.4	2.4	2.2	25000
MRE-11	1.8	1.4	2.7	2.2	21500
MRE-12	2.0	1.5	3.5	2.5	19500
MRE-13	2.0	1.5	3.9	2.8	17500
MRE-14	2.0	1.5	4.2	2.8	15500
MRE-15	2.0	1.5	4.5	3.2	14000

NOTE: CONTACT ROTOR CLIP FOR AVAILABILITY OF SIZES LISTED. LARGER SIZES MAY BE AVAILABLE UPON REQUEST.

HARDNESS RANGES: STAINLESS STEEL RINGS (PH 15-7MO)

RING TYPE	SIZE RANGE	SCALE	ROCKWELL HARDNESS
MRE	4-8	30N	63-69.5
	9-15	C	44-51

HARDNESS RANGES: CARBON STEEL RINGS (SAE 1060-1090)

RING TYPE	SIZE RANGE	SCALE	ROCKWELL HARDNESS
MRE	4-8	30N	67.5-71
	9-15	C	48-52





# JE Shaft Rings (JIS B 2805)

## Radially Assembled, External 'E', JIS

Perhaps the most popular and widely used radial retaining ring is the "E" (so named because it is shaped like the letter "E").

Three prongs make contact with the bottom of the groove and provide a shoulder for effective retention of assemblies.

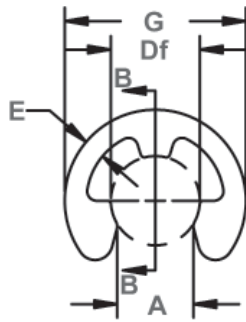

Free Diameter & Ring Measurements  
With Section B-B

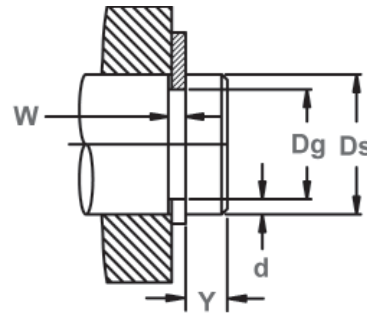
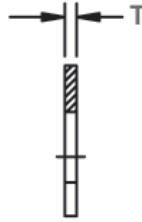

Shaft Diameter & Groove Dimensions

RING NO.	SHAFT Diameter Ds (mm)		GROOVE SIZE				RING SIZE											
			DIAMETER		WIDTH		EDGE MARGIN	FREE DIAMETER		THICKNESS ***		GAP		BEAM WIDTH	FREE OUTSIDE DIA.			
	From	To	Dg	Tol.	W	Tol.	Y Min.	Df	Tol.	T	Tol.	A	Tol.	E	G	Tol.		
JE-0,8	1	1,4	0,8	+0,05	0,3	+0,05	0,4	0,8	-0,08	0,2	±0,02	0,7	-0,25	0,3	2	±0,1		
JE-1,2	1,4	2,0	1,2	+0,06	0,4		0,6	1,2		-0,09	0,3	±0,025		1	-0,30		0,4	3
JE-1,5	2,0	2,5	1,5		0,5		0,8	1,5			0,4	±0,03		1,3			0,6	4
JE-2	2,5	3,2	2,0		0,5	1,0	2	0,4	±0,03		1,7	0,7	5					
JE-2,5	3,2	4,0	2,5	+0,075	0,5	+0,10	1,0	2,5	-0,12	0,4	±0,04	2,1	-0,35	0,8	6	±0,2		
JE-3	4,0	5,0	3,0		0,7		1,0	3		0,6		2,6		0,9	7			
JE-4	5,0	7,0	4,0		0,7		1,2	4		0,6		3,5		1,1	9			
JE-5	6,0	8,0	5,0	+0,09	0,7	+0,10	1,2	5	-0,15	0,6	±0,04	4,3	-0,35	1,2	11	±0,2		
JE-6	7,0	9,0	6,0		0,9		1,2	6		0,8		5,2		1,4	12			
JE-7	8,0	11,0	7,0		0,9		1,5	7		0,8		6,1		1,6	14			
JE-8	9,0	12,0	8,0	+0,09	0,9	+0,10	1,8	8	-0,15	0,8	±0,04	6,9	-0,35	1,8	16	±0,2		
JE-9	10,0	14,0	9,0		0,9		2,0	9		0,8		7,8		2,0	18			
JE-10	11,0	15,0	10,0		1,15		2,0	10		1,0		8,7		2,2	20			
JE-12	13,0	18,0	12,0	+0,11	1,15	+0,14	2,5	12	-0,18	1,0	±0,05	10,4	-0,45	2,4	23	±0,3		
JE-15	16,0	24,0	15,0		1,65		3,0	15		1,5		±0,06		13,0	2,8		29	
JE-19	20,0	31,0	19,0		1,65		3,5	19		1,5		±0,06		16,5	4,0		37	
JE-24	25,0	38,0	24,0	+0,13	1,65	+0,14	4,0	24	-0,21	2,0	±0,07	20,8	-0,50	5,0	44	±0,3		
					2,2		4,0	24		2,0		±0,07		20,8	5,0		44	

ALL DIMENSIONS IN MILLIMETERS.

\*\*\*FOR PLATED RINGS, ADD 0.05 TO THE LISTED MAXIMUM THICKNESS. MAXIMUM RING THICKNESS WILL BE A MINIMUM OF 0.005 LESS THAN THE LISTED GROOVE WIDTH (W) MINIMUM.

### HARDNESS RANGES: STAINLESS STEEL RINGS (PH 15-7MO)

RING TYPE	SIZE RANGE	SCALE	ROCKWELL HARDNESS
JE	0,8-2,5	15N	82.5-86*
	3-9	30N	63-69.5
	10-24	C	44-51

### HARDNESS RANGES: BERYLLIUM COPPER RINGS

RING TYPE	SIZE RANGE	SCALE	ROCKWELL HARDNESS
JE	0,8-2,5	15N	79-82*
	3-9	30N	56.5-62
	10-24	C	37-43

### HARDNESS RANGES: CARBON STEEL RINGS (SAE 1060-1090)

RING TYPE	SIZE RANGE	SCALE	ROCKWELL HARDNESS
JE	0,8-2,5	15N	82.5-87
	3-9	30N	63-71
	10-24	C	44-53

\*HARDNESS CAN NOT BE CHECKED WITH ANY DEGREE OF ACCURACY DIRECTLY ON THESE RINGS.

Installation tools can be found at [rotorclip.com/pliers\\_tools\\_applicators\\_kits](http://rotorclip.com/pliers_tools_applicators_kits)



# Snap Ring, Internal, Inch

Designed for needle bearings, once installed in the groove of a housing/bore, the portion of the ring protruding from the groove holds an assembly in place.

# HN Constant Section Rings

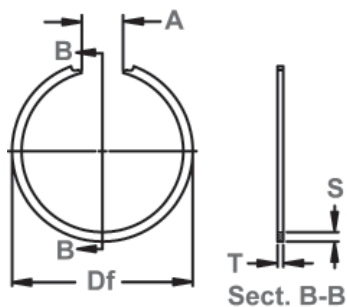

Free Diameter & Ring Measurement with Section B-B

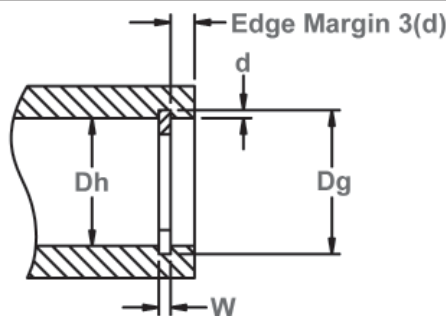

Housing Diameter & Groove Dimensions

Material SAE 1060-1075

RING SIZE	HOUSING DIAMETER			GROOVE SIZE			RING DIMENSIONS					ALLOWABLE STATIC THRUST LOAD (Lbs.)			
				DIAMETER		WIDTH	DEPTH	FREE DIAMETER		THICKNESS	SECTION			FREE GAP	
	Dh DEC	Dh FRACT.	Dh mm	Dg	TOL.	W	d	Df	TOL.	T	S			TOL.	A Min
HN-112	1.125	1-1/8	28.58	1.181	±.005	.046	.028	1.196	+.031	±.002	.093	±.003	.375	.562	1100
HN-125	1.250	1-1/4	31.75	1.310			.030	1.330		.042	.093		.375	.562	1360
HN-137	1.375	1- 3/8	34.93	1.435			.030	1.460		.042	.093		.375	.562	1600
HN-150	1.500	1-1/2	38.10	1.580			.040	1.600	.042	.125	.375		.562	1900	
HN-162	1.625	1-5/8	41.28	1.705			.040	1.725	.042	.125	.437		.750	1930	
HN-175	1.750	1-3/4	44.45	1.830			.040	1.855	.042	.125	.437		.750	1960	
HN-187	1.875	1-7/8	47.63	1.965			.045	1.990	.042	.156	.437		.750	2090	
HN-200	2.000	2	50.80	2.090			.045	2.115	.042	.156	.437		.750	2200	
HN-206	2.062	2-1/16	52.37	2.152			.045	2.177	.042	.156	.437		.750	2340	
HN-218	2.187	2-3/16	55.55	2.277			.045	2.302	.042	.156	.437		.750	2700	
HN-231	2.312	2-5/16	58.72	2.402	±.006	.068	.045	2.432	+.078	.042	.156	±.005	.437	.750	2900
HN-243	2.437	2-7/16	61.90	2.527			.045	2.557		.042	.156		.437	.750	3000
HN-256	2.562	2-9/16	65.07	2.652			.045	2.682		.042	.156		.437	.750	3200
HN-300	3.000	3	76.20	3.124			.062	3.154	.062	.187	.562		.938	6250	
HN-325	3.250	3-1/4	82.55	3.374			.062	3.404	.062	.187	.562		.938	6500	
HN-350	3.500	3-1/2	88.90	3.624			.062	3.654	.062	.187	.562		.938	6700	
HN-375	3.750	3-3/4	95.25	3.874			.062	3.904	.062	.187	.562		.938	6100	
HN-400	4.000	4	101.60	4.125			.062	4.155	.062	.187	.562		.938	7000	
HN-425	4.250	4-1/4	107.95	4.394			.072	4.429	.078	.218	.625		1.062	9100	
HN-450	4.500	4-1/2	114.30	4.644			.072	4.679	.078	.218	.625		1.062	9400	
HN-475	4.750	4-3/4	120.65	4.894	.072	4.929	.078	.218	.625	1.062	9200				
HN-500	5.000	5	127.00	5.144	.072	5.184	.078	.218	.625	1.062	9000				
HN-525	5.250	5-1/4	133.35	5.394	.072	5.434	.078	.218	.625	1.062	8800				
HN-575	5.750	5-3/4	146.05	5.894	.072	5.934	.078	.218	.625	1.062	8950				
HN-600	6.000	6	152.40	6.160	±.007	.103	.080	6.220	+.125	.093	.250	±.005	.875	1.437	9000
HN-650	6.500	6-1/2	165.10	6.660			.080	6.730		.093	.250		.875	1.437	7500
HN-700	7.000	7	177.80	7.160			.080	7.240		.093	.250		.875	1.437	6200
HN-725	7.250	7-1/4	184.15	7.410	±.008	.103	.080	7.500	+.187	.093	.250	±.005	1.000	1.750	6100
HN-750	7.500	7-1/2	190.50	7.660			.080	7.760		.093	.250		1.000	1.750	6000
HN-800	8.000	8	203.20	8.160			.080	8.285		.093	.250		1.000	1.750	5700

Hardness: All Ring Sizes-HRC 42-52

For alternate cutoff styles, contact Rotor Clip Technical Sales at +1.732.469.7333 (E-mail: tech@rotorclip.com)





# UHO Constant Section Rings

## Snap Ring, Internal Notched, Inch

Once installed in the groove of a housing/bore, the portion of the ring protruding from the groove holds an assembly in place.

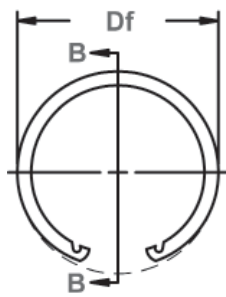

Free Diameter & Ring  
Measurement With Section B-B

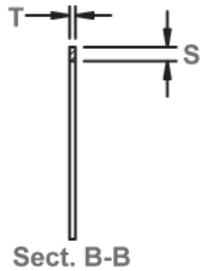

Sect. B-B

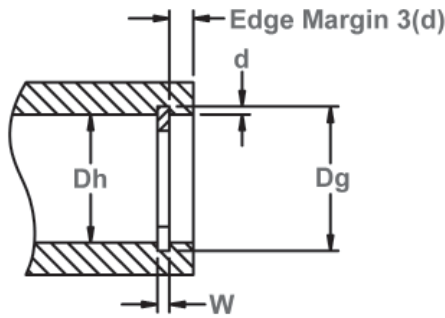

Housing Diameter &  
Groove Dimensions

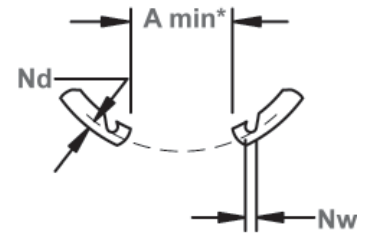

\*Ring installed in groove

Material SAE 1060-1075

RING SIZE	HOUSING DIAMETER			GROOVE SIZE			RING DIMENSIONS					ALLOWABLE STATIC THRUST LOAD (Lbs.)			
				DIAMETER		WIDTH	DEPTH	FREE DIAMETER		THICKNESS	SECTION		GAP	NOTCH DIMENSIONS	
	Dh DEC	Dh FRACT.	Dh mm	Dg	TOL.	W	d	Df	TOL.	T +/- .002	S +/- .005		A Min*	Nd +0/- .030	Nw REF
UHO-175	1.750	1-3/4	44.4	1.858	+/- .005	.068	.054	1.878	+ .070	.062	.156	.370	.078	.093	4100
UHO-181	1.812	1-13/16	46.0	1.922			.055	1.942		.062	.156	.370	.078	.093	4280
UHO-185	1.850	-	47.0	1.962			.056	1.982		.062	.156	.400	.078	.093	4380
UHO-187	1.875	1-7/8	47.6	1.989			.057	2.014		.062	.156	.400	.078	.093	4650
UHO-193	1.938	1-15/16	49.2	2.056			.059	2.081		.062	.156	.400	.078	.093	5000
UHO-200	2.000	2	50.8	2.122			.061	2.147		.062	.156	.420	.078	.093	5350
UHO-206	2.047	-	52.0	2.171			.062	2.201		.078	.171	.420	.085	.093	6490
UHO-206	2.062	2-1/16	52.4	2.186			.062	2.201		.078	.171	.450	.085	.093	6490
UHO-212	2.125	2-1/8	54.0	2.251			.063	2.271		.078	.171	.450	.085	.093	6810
UHO-218	2.165	-	55.0	2.295			.065	2.338		.078	.171	.430	.085	.093	7240
UHO-218	2.188	2-3/16	55.6	2.318	.065	2.338	.078	.171	.470	.085	.093	7240			
UHO-225	2.250	2-1/4	57.1	2.382	.066	2.402	.078	.171	.450	.085	.093	7560			
UHO-231	2.312	2-5/16	58.7	2.450	.069	2.470	.078	.171	.450	.085	.093	8120			
UHO-237	2.375	2-3/8	60.3	2.517	.071	2.537	.078	.188	.470	.093	.093	8580			
UHO-244	2.440	2-7/16	62.0	2.584	.072	2.604	.078	.188	.470	.093	.093	8940			
UHO-250	2.500	2-1/2	63.5	2.648	.074	2.673	.078	.188	.470	.093	.093	9410			
UHO-253	2.531	2-17/32	64.3	2.681	.075	2.706	.078	.188	.470	.093	.093	9660			
UHO-256	2.562	2-9/16	65.1	2.714	.076	2.739	.093	.188	.530	.093	.093	9910			
UHO-262	2.625	2-5/8	66.7	2.781	.078	2.806	.093	.188	.530	.093	.093	10420			
UHO-268	2.677	-	68.0	2.837	.080	2.868	.093	.188	.530	.093	.093	10900			
UHO-268	2.688	2-11/16	68.3	2.848	.080	2.868	.093	.188	.560	.093	.093	10900			
UHO-275	2.750	2-3/4	69.8	2.914	.082	2.944	.093	.188	.590	.093	.093	11470			
UHO-281	2.812	2-13/16	71.4	2.980	.084	3.025	.093	.188	.590	.093	.093	12200			
UHO-281	2.835	-	72.0	3.005	.085	3.025	.093	.188	.660	.093	.093	12200			
UHO-287	2.875	2-7/8	73.0	3.051	.088	3.086	.093	.203	.620	.100	.093	12870			
UHO-295	2.953	-	75.0	3.135	.091	3.175	.093	.203	.620	.100	.093	13480			
UHO-300	3.000	3	76.2	3.182	.091	3.222	.093	.203	.620	.100	.093	13890			
UHO-306	3.062	3-1/16	77.8	3.248	.093	3.288	.109	.218	.650	.109	.125	14490			
UHO-312	3.125	3-1/8	79.4	3.315	.095	3.353	.109	.218	.650	.109	.125	15110			
UHO-315	3.149	-	80.0	3.341	.096	3.388	.109	.218	.650	.109	.125	15420			
UHO-315	3.156	3-5/32	80.2	3.348	.096	3.388	.109	.218	.680	.109	.125	15420			
UHO-325	3.250	3-1/4	82.5	3.446	.098	3.488	.109	.218	.680	.109	.125	16210			
UHO-334	3.346	3-11/32	85.0	3.546	.100	3.590	.109	.218	.680	.109	.125	17030			
UHO-347	3.469	3-15/32	88.1	3.675	.103	3.721	.109	.234	.710	.120	.125	18190			
UHO-350	3.500	3-1/2	88.9	3.710	.105	3.760	.109	.234	.710	.120	.125	18700			
UHO-354	3.543	-	90.0	3.755	.106	3.805	.109	.234	.740	.120	.125	19400			
UHO-354	3.562	3-9/16	90.5	3.776	.107	3.805	.109	.234	.810	.120	.125	19400			

\*Installed In Groove.

Material: SAE 1060/1075 carbon spring steel

Hardness:	Ring Size	HRc
	175-700	45-52
	725-1000	40-47

For alternate cutoff styles, contact Rotor Clip Technical Sales at +1.732.469.7333 (E-mail: tech@rotorclip.com)



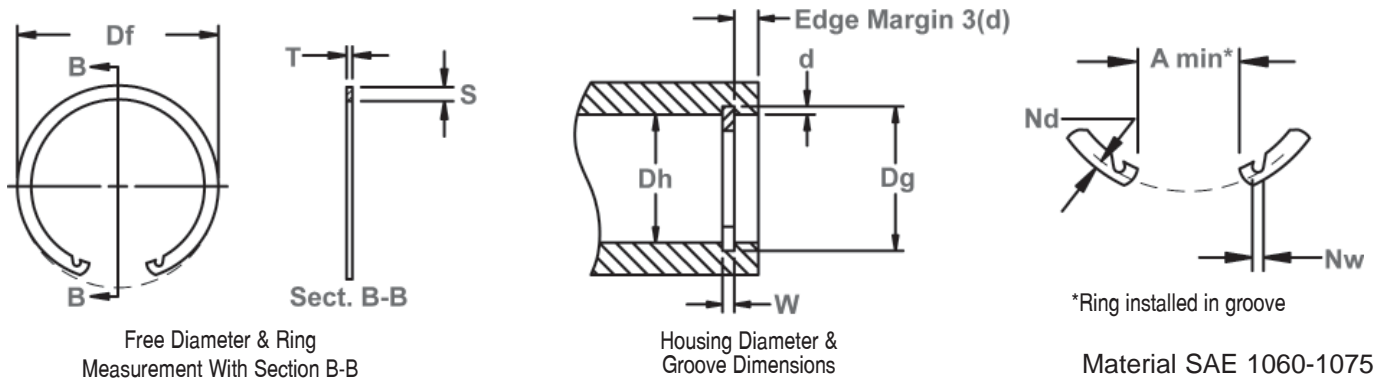

RING SIZE	HOUSING DIAMETER			GROOVE SIZE			RING DIMENSIONS					ALLOWABLE STATIC THRUST LOAD (Lbs.)			
				DIAMETER		WIDTH	DEPTH	FREE DIAMETER		THICKNESS	SECTION		GAP	NOTCH DIMENSIONS	
	Dh DEC	Dh FRACT.	Dh mm	Dg	TOL.	W	d	Df	TOL.	T +/--.002	S +/--.005		A Min*	DEPTH Nd +0/-0.030	WIDTH Nw REF
UHO-362	3.625	3-5/8	92.1	3.841	+/--.006	.120 +.005 -.000	.108	3.895	+.100 -.000	.109	.234	.740	.120	.125	19930
UHO-375	3.740	-	95.0	3.964			.112	4.030		.109	.250	.740	.125	.125	21380
UHO-375	3.750	3-3/4	95.2	3.974			.112	4.030		.109	.250	.780	.125	.125	21380
UHO-387	3.875	3-7/8	98.4	4.107			.116	4.165		.109	.250	.780	.125	.125	22880
UHO-393	3.938	3-15/16	100.0	4.174			.118	4.234		.109	.250	.810	.125	.125	23650
UHO-400	4.000	4	101.6	4.240			.120	4.300		.109	.250	.810	.125	.125	24430
UHO-412	4.125	4-1/8	104.8	4.365			.120	4.430		.109	.250	.810	.125	.125	25190
UHO-425	4.250	4-1/4	108.0	4.490			.120	4.555		.109	.250	.810	.125	.125	25960
UHO-433	4.331	-	110.0	4.571			.120	4.641		.109	.250	.810	.125	.125	26450
UHO-450	4.500	4-1/2	114.3	4.740			.120	4.815		.109	.281	.840	.140	.156	27490
UHO-462	4.625	4-5/8	117.5	4.865			.120	4.940		.109	.281	.840	.140	.156	28250
UHO-475	4.724	-	120.0	4.969			.122	5.070		.109	.281	.840	.140	.156	29000
UHO-475	4.750	4-3/4	120.6	4.995			.122	5.070		.109	.281	.910	.140	.156	29000
UHO-500	5.000	5	127.0	5.260			.130	5.340		.109	.281	.930	.140	.156	33100
UHO-525	5.250	5-1/4	133.3	5.520			+/--.007	.139 +.006 -.000		.135	5.600	+.120 -.000	.125	.312	1.000
UHO-537	5.375	5-3/8	136.5	5.650	.135	5.735			.125	.312	1.000		.156	.156	36930
UHO-550	5.500	5-1/2	139.7	5.770	.135	5.860			.125	.312	1.000		.156	.156	37790
UHO-575	5.750	5-3/4	146.0	6.020	.135	6.120			.125	.312	1.000		.156	.156	39500
UHO-600	6.000	6	152.4	6.270	.135	6.380			.125	.312	1.000		.156	.156	41220
UHO-625	6.250	6-1/4	158.7	6.530	.140	6.640			.156	.343	1.030		.171	.156	44530
UHO-650	6.500	6-1/2	165.1	6.790	.145	6.905			.156	.343	1.090		.171	.156	47970
UHO-662	6.625	6-5/8	168.3	6.925	.150	7.045			.156	.343	1.120		.171	.156	50580
UHO-675	6.750	6-3/4	171.4	7.055	.152	7.180			.156	.343	1.130		.171	.156	52220
UHO-700	7.000	7	177.8	7.315	.157	7.445			.156	.343	1.140		.171	.156	55930
UHO-725	7.250	7-1/4	184.1	7.575	.162	7.705			.187	.375	1.140		.187	.187	59700
UHO-750	7.500	7-1/2	190.5	7.840	.170	7.975			.187	.375	1.150		.187	.187	64900
UHO-775	7.750	7-3/4	196.8	8.100	.175	8.240			.187	.375	1.160		.187	.187	68700
UHO-800	8.000	8	203.2	8.360	.180	8.505			.187	.437	1.200		.218	.187	72900
UHO-825	8.250	8-1/4	209.5	8.620	.185	8.770			.187	.437	1.230		.218	.187	77600
UHO-850	8.500	8-1/2	215.9	8.880	.190	9.035	.187	.437	1.270	.218	.187	81800			
UHO-875	8.750	8-3/4	222.2	9.144	.197	9.305	.187	.437	1.320	.218	.187	87300			
UHO-900	9.000	9	228.6	9.404	.202	9.564	.187	.437	1.370	.218	.187	92400			
UHO-925	9.250	9-1/4	235.0	9.668	.209	9.833	.187	.500	1.400	.250	.187	98000			
UHO-950	9.500	9-1/2	241.3	9.930	.215	10.100	.187	.500	1.500	.250	.187	103900			
UHO-975	9.750	9-3/4	247.7	10.190	.220	10.365	.187	.500	1.620	.250	.187	10900			
UHO-1000	10.000	10	254.0	10.450	.225	10.630	.187	.500	1.750	.250	.187	114600			

\*Installed In Groove.



# UHB Constant Section

**Snap Ring, Internal, Inch**  
Once installed in the groove of a housing/bore, the portion of the ring protruding from the groove holds an assembly in place.

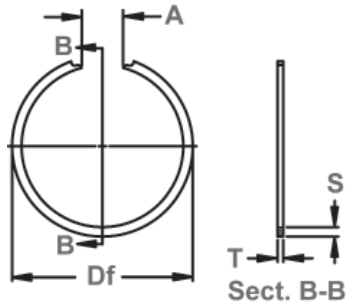

Free Diameter & Ring Measurement with Section B-B

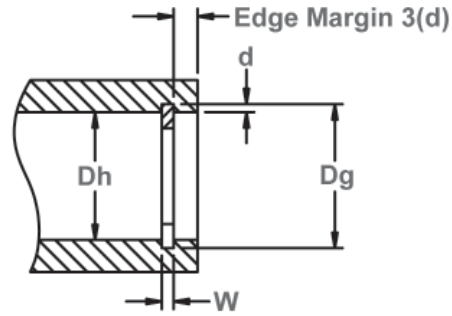

Housing Diameter & Groove Dimensions

Material SAE 1060-1075

RING SIZE	HOUSING DIAMETER			GROOVE SIZE			RING DIMENSIONS					ALLOWABLE STATIC THRUST LOAD (Lbs.)			
				DIAMETER		WIDTH	DEPTH	FREE DIAMETER		THICKNESS	SECTION		FREE GAP A		
	Dh DEC	Dh FRACT.	Dh mm	Dg	TOL.	W	d	Df	TOL.	T +/- .002	S		TOL.	Min	Max
UHB-37	.375	3/8	9.5	0.395	+/- .003	.028	.010	0.400	+ .031	.025	.035	+/- .003	.125	.218	250
UHB-43	.438	7/16	11.1	0.462		.012	0.467	- .000	.025	.035	.125		.218	300	
UHB-50	.500	1/2	12.7	0.524		.012	0.530	+ .025 - .000	.035	.040	.187		.344	470	
UHB-51	.512		13.0	0.536		.012	0.542		.035	.040	.187		.344	480	
UHB-56	.562	9/16	14.3	0.590		.014	0.600		.035	.048	.187		.344	510	
UHB-62	.625	5/8	15.9	0.657		.016	0.670		.035	.048	.187		.344	620	
UHB-68	.688	11/16	17.5	0.720		.016	0.733		.035	.048	.187		.344	700	
UHB-75	.750	3/4	19.1	0.786		.018	0.799		.035	.048	.187		.344	750	
UHB-77	.777		19.7	0.813		.018	0.827		.042	.062	.187		.344	1020	
UHB-81	.812	13/16	20.6	0.852		.020	0.867		.042	.062	.187		.344	1090	
UHB-87	.875	7/8	22.2	0.919	.022	0.934	.042		.062	.281	.438	1130			
UHB-90	.901		22.9	0.945	.022	0.961	.042		.078	.281	.438	1260			
UHB-93	.938	15/16	23.8	0.986	.024	1.003	.042	.078	.281	.438	1360				
UHB-100	1.000	1	25.4	1.052	.024	1.070	.042	.078	.281	.438	1470				
UHB-102	1.023		26.0	1.075	.026	1.094	.042	.093	.281	.438	1500				
UHB-106	1.062	1-1/16	27.0	1.114	.026	1.134	.050	.093	.281	.438	1780				
UHB-112	1.125	1-1/8	28.6	1.181	.028	1.202	.050	.093	.375	.562	1880				
UHB-118	1.188	1-3/16	30.2	1.248	.030	1.270	.050	.093	.375	.562	1990				
UHB-125	1.250	1-1/4	31.8	1.314	.032	1.337	.050	.109	.375	.562	2090				
UHB-131	1.312	1-5/16	33.3	1.380	.034	1.404	.050	.109	.375	.562	2200				
UHB-137	1.375	1-3/8	34.9	1.447	.036	1.472	.050	.109	.375	.562	2300				
UHB-143	1.438	1-7/16	36.5	1.510	.036	1.535	.050	.125	.375	.562	2460				
UHB-145	1.456	-	36.1	1.532	.038	1.557	.050	.125	.375	.562	2490				
UHB-150	1.500	1-1/2	38.1	1.576	.038	1.607	.050	.125	.375	.562	2560				
UHB-156	1.562	1-9/16	39.7	1.642	.040	1.668	.062	.125	.437	.687	3060				
UHB-162	1.625	1-5/8	41.3	1.709	.042	1.736	.062	.141	.437	.687	3190				
UHB-165	1.653	-	42.0	1.737	.042	1.765	.062	.141	.437	.687	3240				
UHB-168	1.688	1-11/16	42.9	1.776	.044	1.804	.062	.156	.437	.687	3370				
UHB-175	1.750	1-3/4	44.4	1.842	.046	1.870	.062	.156	.437	.687	3510				
UHB-181	1.812	1-13/16	46.0	1.904	.046	1.933	.062	.156	.437	.687	3640				
UHB-185	1.850	-	47.0	1.946	.048	1.975	.062	.156	.437	.687	3710				
UHB-187	1.875	1-7/8	47.6	1.971	.048	2.000	.062	.156	.437	.687	3760				

Hardness: All Ring Sizes - HRC 42-52

For alternate cutoff styles, contact Rotor Clip Technical Sales at +1.732.469.7333 (E-mail: tech@rotorclip.com)

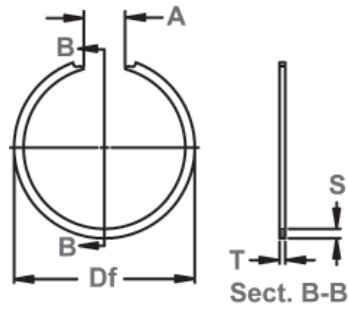

Free Diameter & Ring Measurement with Section B-B

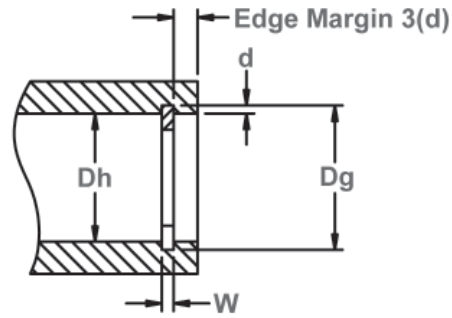

Housing Diameter & Groove Dimensions

Material SAE 1060-1075

RING SIZE	HOUSING DIAMETER			GROOVE SIZE					RING DIMENSIONS					ALLOWABLE STATIC THRUST LOAD (Lbs.)	
				DIAMETER		WIDTH	DEPTH	FREE DIAMETER		THICKNESS	SECTION		FREE GAP A		
	Dh DEC	Dh FRACT.	Dh mm	Dg	TOL.	W	d	Df	TOL.	T +/- .002	S	TOL.	Min		Max
UHB-193	1.938	1-15/16	49.2	2.038		.068	.050	2.068		.062	.156		.500	.750	3870
UHB-196	1.968	1-31/32	50.0	2.068	+/- .005	+.004	.050	2.098		.062	.156		.500	.750	3935
UHB-200	2.000	2	50.8	2.100		-.000	.050	2.131		.062	.156		.500	.750	4000
UHB-206	2.062	2-1/16	52.4	2.166			.052	2.197		.062	.156		.500	.750	4380
UHB-212	2.125	2-1/8	54.0	2.229			.052	2.260		.078	.156		.500	.750	5140
UHB-218	2.188	2-3/16	55.6	2.296			.054	2.331		.078	.171		.500	.750	5470
UHB-225	2.250	2-1/4	57.1	2.358		.086	.054	2.393	+ .046	.078	.171		.500	.750	5630
UHB-231	2.312	2-5/16	58.7	2.424		+.005	.056	2.459	- .000	.078	.171		.500	.750	5790
UHB-237	2.375	2-3/8	60.3	2.487		-.000	.056	2.523		.078	.171		.500	.750	5950
UHB-244	2.440	2-7/16	62.0	2.556	+/- .006		.058	2.592		.078	.187		.500	.750	6270
UHB-250	2.500	2-1/2	63.5	2.616			.058	2.653		.078	.187		.500	.750	6350
UHB-253	2.531	2-17/32	64.3	2.651			.060	2.688		.078	.187		.500	.750	6510
UHB-256	2.562	2-9/16	65.1	2.686			.062	2.726		.093	.187		.562	.812	8400
UHB-262	2.625	2-5/8	66.7	2.750			.062	2.790		.093	.187		.562	.812	8650
UHB-268	2.688	2-11/16	68.3	2.816			.062	2.856		.093	.187	+/- .005	.562	.812	8800
UHB-271	2.717	-	68.8	2.842			.064	2.882		.093	.187		.562	.812	8875
UHB-275	2.750	2-3/4	69.8	2.878		.103	.064	2.918		.093	.187		.562	.812	8950
UHB-281	2.812	2-13/16	71.4	2.945		+.005	.066	2.985		.093	.187		.625	.875	9100
UHB-283	2.835	-	72.0	2.966		-.000	.066	3.006		.093	.187		.625	.875	9250
UHB-287	2.875	2-7/8	73.0	3.011			.068	3.056		.093	.187		.625	.875	9400
UHB-300	3.000	3	76.2	3.136			.068	3.181	+ .062	.093	.187		.625	.875	9550
UHB-306	3.062	3-1/16	77.8	3.202		-.000	.070	3.247		.109	.218		.625	.875	10470
UHB-312	3.125	3-1/8	79.4	3.265			.070	3.311		.109	.218		.625	.875	10690
UHB-315	3.156	3-5/32	80.2	3.296			.070	3.342		.109	.218		.625	.875	10800
UHB-325	3.250	3-1/4	82.5	3.394			.072	3.442		.109	.218		.718	1.062	11120
UHB-334	3.346	3-11/32	85.0	3.490	+/- .006		.072	3.539		.109	.218		.718	1.062	11450
UHB-346	3.469	3-15/32	88.1	3.613		+.006	.072	3.663		.109	.218		.718	1.062	11870
UHB-350	3.500	3-1/2	88.9	3.648		-.000	.074	3.700		.109	.250		.718	1.062	11970
UHB-354	3.543	-	90.0	3.691			.074	3.745	+ .078	.109	.250		.718	1.062	12120
UHB-356	3.562	3-9/16	90.5	3.710			.074	3.766	- .000	.109	.250		.718	1.062	12190
UHB-362	3.625	3-5/8	92.1	3.773			.074	3.831		.109	.250		.718	1.062	12380
UHB-375	3.750	3-3/4	95.2	3.902			.076	3.962		.109	.250		.718	1.062	12600

Hardness: All Ring Sizes - HRC 42-52

For alternate cutoff styles, contact Rotor Clip Technical Sales at +1.732.469.7333 (E-mail: tech@rotorclip.com)



# UHB Constant Section

**Snap Ring, Internal, Inch**  
Once installed in the groove of a housing/bore, the portion of the ring protruding from the groove holds an assembly in place.

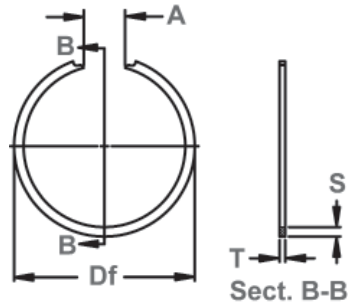

Free Diameter & Ring Measurement with Section B-B

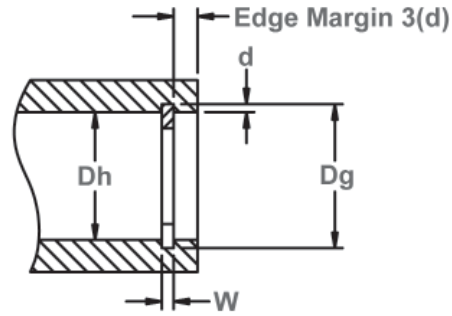

Housing Diameter & Groove Dimensions

Material SAE 1060-1075

RING SIZE	HOUSING DIAMETER			GROOVE SIZE			RING DIMENSIONS				ALLOWABLE STATIC THRUST LOAD (Lbs.)				
				DIAMETER		WIDTH	DEPTH	FREE DIAMETER		THICKNESS		SECTION		FREE GAP A	
	Dh DEC	Dh FRACT.	Dh mm	Dg	TOL.	W	d	Df	TOL.	T +/- .002		S	TOL.	Min	Max
UHB-387	3.875	3-7/8	98.4	4.027			.076	4.089	+.078	.109	.250		.718	1.062	12820
UHB-393	3.938	3-15/16	100.0	4.094			.078	4.156	-.000	.109	.250		.718	1.062	13230
UHB-400	4.000	4	101.6	4.156			.078	4.221		.109	.250		.875	1.312	13690
UHB-412	4.125	4-1/8	104.8	4.285			.080	4.355		.109	.250		.875	1.312	14110
UHB-425	4.250	4-1/4	108.0	4.410	+/- .006	.120	.080	4.485		.109	.250		.875	1.312	14540
UHB-433	4.331	-	110.0	4.490		+.006	.080	4.565	+.093	.109	.250		.875	1.312	14960
UHB-443	4.436	4-7/16	112.7	4.596		-.000	.080	4.670	-.000	.109	.250		.875	1.312	15170
UHB-450	4.500	4-1/2	114.3	4.664			.082	4.744		.109	.250		.875	1.312	15390
UHB-462	4.625	4-5/8	117.5	4.795			.085	4.875		.109	.250		.875	1.312	15830
UHB-475	4.750	4-3/4	120.6	4.926			.088	5.011		.109	.281		.875	1.312	16250
UHB-500	5.000	5	127.0	5.180			.090	5.265		.109	.281		.875	1.312	17110
UHB-525	5.250	5-1/4	133.3	5.435			.092	5.530		.125	.312		1.000	1.500	20590
UHB-537	5.375	5-3/8	136.5	5.565	+/- .007	.139	.095	5.660	+.125	.125	.312		1.000	1.500	21110
UHB-550	5.500	5-1/2	139.7	5.696		+.006	.098	5.796	+.125	.125	.312		1.000	1.500	21790
UHB-575	5.750	5-3/4	146.0	5.950		-.000	.100	6.050	-.000	.125	.312	+/- .005	1.000	1.500	22570
UHB-600	6.000	6	152.4	6.204			.102	6.309		.125	.312		1.000	1.500	23550
UHB-625	6.250	6-1/4	158.7	6.458			.104	6.568		.156	.343		1.000	1.500	29420
UHB-650	6.500	6-1/2	165.1	6.712		.174	.106	6.832	+.156	.156	.343		1.125	1.812	30610
UHB-662	6.625	6-5/8	168.3	6.845		+.006	.110	6.975	+.156	.156	.343		1.125	1.812	31400
UHB-675	6.750	6-3/4	171.4	6.970		-.000	.110	7.100	-.000	.156	.343		1.125	1.812	32640
UHB-700	7.000	7	177.8	7.220			.110	7.350		.156	.343		1.125	1.812	34850
UHB-725	7.250	7-1/4	184.1	7.500			.125	7.630		.187	.375		1.375	2.250	38060
UHB-750	7.500	7-1/2	190.5	7.750			.125	7.890		.187	.375		1.375	2.250	39450
UHB-800	8.000	8	203.2	8.250	+/- .008	.209	.125	8.400		.187	.375		1.375	2.250	41960
UHB-825	8.250	8-1/4	209.5	8.540			.145	8.665		.187	.437		1.625	2.500	43320
UHB-850	8.500	8-1/2	215.9	8.790		+.006	.145	8.915	+.187	.187	.437		1.625	2.500	44710
UHB-875	8.750	8-3/4	222.2	9.080		-.000	.165	9.205	-.000	.187	.500		1.625	2.500	48900
UHB-900	9.000	9	228.6	9.330			.165	9.455		.187	.500		1.625	2.500	49740
UHB-905	9.250	9-1/4	235.0	9.384			.165	9.509		.187	.500		1.750	2.625	50050
UHB-950	9.500	9-1/2	241.3	9.830			.165	9.955		.187	.500		1.750	2.625	52520
UHB-984	9.750	9-3/4	247.7	10.170			.165	10.295		.187	.500		1.750	2.625	53780
UHB-1000	10.000	10	254.0	10.330			.165	10.455		.187	.500		1.750	2.625	55400

Hardness: All ring sizes - HRC 42-52

For alternate cutoff styles, contact Rotor Clip Technical Sales at 1-800-557-6867 (E-mail: tech@rotorclip.com)

# Snap Ring, External, Inch

Once installed in the groove of a shaft, the portion of the ring protruding from the groove holds an assembly in place.

# USC Constant Section

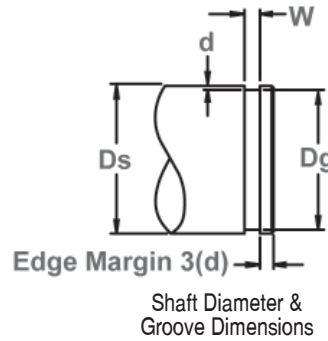
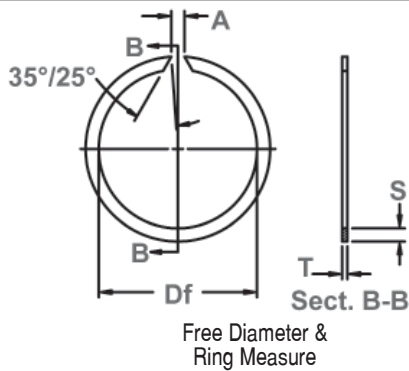

Material: SAE 1060-1075

RING SIZE	SHAFT DIAMETER			GROOVE SIZE			RING DIMENSIONS					ALLOWABLE STATIC THRUST LOAD (Lbs.)			
				DIAMETER		WIDTH	DEPTH	FREE DIAMETER		THICKNESS	SECTION		FREE GAP A		
	Ds DEC	Ds FRACT.	Ds mm	Dg	TOL.	W	d	Df	TOL.	T +/- .002	S		TOL.	Min	Max
USC-31	.312	5/16	7.92	.290			.011	.281		.025	.040		.031	.156	180
USC-34	.344	11/32	8.74	.322			.011	.312	+ .000	.025	.040		.031	.156	190
USC-35	.354	-	8.99	.330		.028	.012	.320	- .015	.025	.040		.031	.156	210
USC-37	.375	3/8	9.53	.351		+ .003	.012	.341		.025	.040		.031	.156	230
USC-39	.393	-	10.31	.369		- .000	.012	.359		.025	.040		.031	.156	260
USC-40	.406	13/32	11.13	.382			.012	.372	+ .000	.025	.040		.031	.156	280
USC-43	.438	7/16	11.91	.412			.013	.402	- .020	.025	.040		.031	.156	300
USC-46	.469	15/32	12.70	.443	+/- .002		.013	.433		.025	.040		.031	.156	320
USC-50	.500	1/2	14.00	.474			.013	.464		.035	.048		.062	.218	460
USC-55	.551	-	14.27	.524		.039	.013	.514		.035	.048		.062	.218	480
USC-56	.562	9/16	15.09	.534		+ .003	.014	.524		.035	.048		.062	.218	490
USC-59	.594	19/32	15.88	.566		- .000	.014	.555	+ .000	.035	.048		.062	.218	510
USC-62	.625	5/8	17.00	.597			.014	.586	- .025	.035	.062	+/- .003	.062	.218	520
USC-66	.669	-	17.00	.640			.015	.630		.035	.062		.062	.218	570
USC-68	.688	11/16	18.00	.656			.016	.644		.042	.062		.062	.218	700
USC-75	.750	3/4	19.05	.716			.017	.703		.042	.062		.062	.218	820
USC-78	.781	25/32	19.84	.745			.018	.733		.042	.062		.062	.218	950
USC-81	.812	13/16	20.62	.776		.046	.018	.764		.042	.062		.062	.218	1010
USC-87	.875	7/8	22.23	.835		+ .003	.020	.820		.042	.078		.093	.250	1100
USC-93	.938	15/16	23.83	.896		- .000	.021	.881		.042	.078		.093	.250	1130
USC-98	.984	63/64	25.00	.940			.022	.925		.042	.078		.093	.250	1170
USC-100	1.000	1	25.40	.956	+/- .003		.022	.941		.042	.093		.156	.312	1200
USC-102	1.023	-	25.98	.977			.023	.962	+ .000	.042	.093		.156	.312	1300
USC-106	1.062	1-1/16	26.97	1.016			.023	1.000	- .031	.050	.093		.156	.312	1600
USC-112	1.125	1-1/8	28.58	1.075			.025	1.060		.050	.093		.156	.312	1880
USC-118	1.188	1-3/16	30.18	1.136			.026	1.121		.050	.093		.156	.312	1990
USC-125	1.250	1-1/4	31.75	1.194		+ .004	.028	1.179		.050	.093		.156	.312	2090
USC-131	1.312	1-5/16	33.32	1.25		- .000	.031	1.232		.050	.093		.156	.312	2100
USC-137	1.375	1-3/8	34.93	1.309	+/- .004		.033	1.291		.050	.109		.156	.312	2300
USC-143	1.438	1-7/16	36.53	1.370			.034	1.351		.050	.109		.156	.312	2460
USC-150	1.500	1-1/2	38.10	1.430			.035	1.408		.050	.109		.156	.312	2500

Hardness: All ring sizes - HRC 42-53

For alternate cutoff styles, contact Rotor Clip Technical Sales at 1-800-557-6867 (E-mail: tech@rotorclip.com)



For the most up-to-date specifications, online ordering, quotations & sample orders, visit [www.rotorclip.com](http://www.rotorclip.com)

Once installed in the groove of a shaft, the portion of the ring protruding from the groove holds an assembly in place.

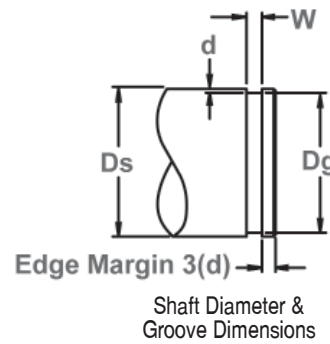
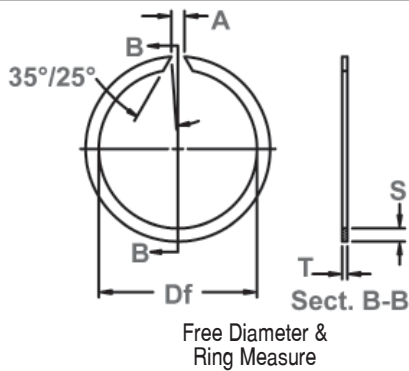

Material: SAE 1060-1075

RING SIZE	SHAFT DIAMETER			GROOVE SIZE			RING DIMENSIONS					ALLOWABLE STATIC THRUST LOAD (Lbs.)			
				DIAMETER		WIDTH	DEPTH	FREE DIAMETER		THICKNESS				SECTION	FREE GAP A
	Ds DEC	Ds FRACT.	Ds mm	Dg	TOL.	W	d	Df	TOL.	T +/- .002	S +/- .005	TOL.	Min	Max	
USC-156	1.562	1-9/16	39.67	1.490	+/- .004	.068 + .004 - .000	.036	1.467	+ .000 - .046	.062	.125	+/- .005	.156	.375	3060
USC-162	1.625	1-5/8	41.28	1.551			.037	1.527		.062	.125		.156	.375	3190
USC-168	1.688	1-11/16	42.90	1.611			.038	1.581		.062	.125		.156	.375	3370
USC-175	1.750	1-3/4	44.40	1.670			.04	1.640		.062	.125		.156	.375	3510
USC-177	1.772	-	45.00	1.687			.042	1.657		.062	.141		.156	.375	3550
USC-181	1.812	1-13/16	46.00	1.728			.042	1.698		.062	.141		.156	.375	3640
USC-187	1.875	1-7/8	47.60	1.789			.043	1.759		.062	.156		.156	.375	3760
USC-196	1.969	1-31/32	50.00	1.879			.045	1.849		.062	.156		.156	.375	3940
USC-200	2.000	2	50.80	1.910			.045	1.880		.062	.156		.156	.375	4010
USC-206	2.062	2-1/16	52.40	1.966			.048	1.936		.078	.156		.156	.375	5350
USC-212	2.125	2-1/8	54.00	2.027	.049	1.997	.078	.156	.156	.375	5470				
USC-215	2.156	2-5/32	54.80	2.056	.050	2.026	.078	.156	.156	.375	5680				
USC-225	2.250	2-1/4	57.10	2.146	.052	2.116	.078	.156	.156	.375	5790				
USC-231	2.312	2-5/16	58.70	2.204	.054	2.174	.078	.187	.156	.375	6300				
USC-237	2.375	2-3/8	60.30	2.265	.055	2.235	.078	.187	.156	.375	6400				
USC-243	2.438	2-7/16	61.90	2.325	.056	2.295	.078	.187	.156	.375	6500				
USC-250	2.500	2-1/2	63.50	2.386	.057	2.356	.078	.187	.156	.375	6600				
USC-255	2.559	-	65.00	2.443	.058	2.413	.078	.187	.156	.375	6700				
USC-262	2.625	2-5/8	66.70	2.505	.060	2.475	.078	.187	.156	.375	6800				
USC-268	2.688	2-11/16	68.30	2.565	.061	2.535	.078	.187	.156	.375	6900				
USC-275	2.750	2-3/4	69.80	2.624	.063	2.594	.093	.187	.187	.437	8460				
USC-287	2.875	2-7/8	73.00	2.743	.066	2.713	.093	.187	.187	.437	8840				
USC-293	2.938	2-15/16	74.60	2.801	.068	2.771	.093	.187	.187	.437	9030				
USC-300	3.000	3	76.20	2.860	.070	2.830	.093	.218	.187	.437	9230				
USC-306	3.062	3-1/16	77.80	2.920	.071	2.890	.093	.218	.187	.437	9420				
USC-312	3.125	3-1/8	79.40	2.981	.072	2.951	.093	.218	.187	.437	9630				
USC-315	3.156	3-5/32	80.20	3.010	.073	2.980	.093	.218	.187	.437	9800				
USC-325	3.250	3-1/4	82.50	3.100	.075	3.070	.093	.250	.187	.437	10000				
USC-334	3.346	3-11/32	85.00	3.190	.077	3.160	.093	.250	.187	.437	10290				
USC-343	3.438	3-7/16	87.3	3.281	.078	3.251	.093	.250	.187	.437	10570				

Hardness: All ring sizes - HRC 42-53

For alternate cutoff styles, contact Rotor Clip Technical Sales at +1.732.469.7333 (E-mail: tech@rotorclip.com)



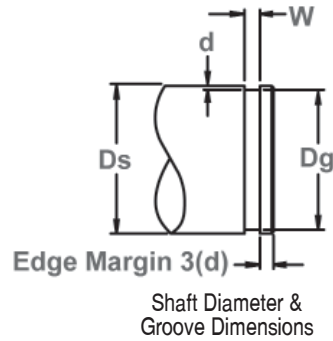
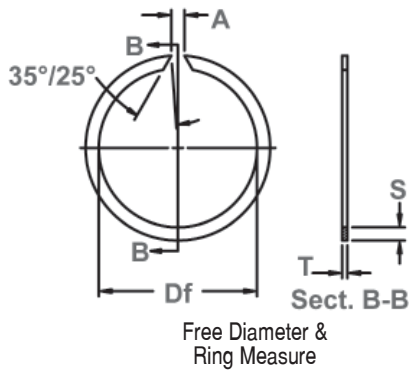

Material: SAE 1060-1075

RING SIZE	SHAFT DIAMETER			GROOVE SIZE			RING DIMENSIONS					FREE GAP A		ALLOWABLE STATIC THRUST LOAD (Lbs.)	
				DIAMETER		WIDTH	DEPTH	FREE DIAMETER		THICKNESS					SECTION
	Ds DEC	Ds FRACT.	Ds mm	Dg	TOL.	W	d	Df	TOL.	T +/- .002	S +/- .005	TOL.	Min		Max
USC-350	3.500	3-1/2	88.9	3.340			.080	3.305		.109	.250		.250	.562	11970
USC-354	3.543	-	90.0	3.381			.081	3.346		.109	.250		.250	.562	12120
USC-362	3.625	3-5/8	92.1	3.458			.083	3.423	+ .000	.109	.250		.250	.562	12300
USC-368	3.688	3-11/16	93.7	3.517			.085	3.482	- .078	.109	.250		.250	.562	12600
USC-375	3.750	3-3/4	95.2	3.576			.087	3.541		.109	.250		.250	.562	12800
USC-387	3.875	3-7/8	98.4	3.697		.120	.089	3.657		.109	.281		.250	.562	13200
USC-393	3.938	3-15/16	100.0	3.758		+ .005	.090	3.713		.109	.281		.250	.562	13470
USC-400	4.000	4	101.6	3.816		- .000	.092	3.771		.109	.281		.250	.656	13650
USC-425	4.250	4-1/4	108.0	4.066	+/- .006		.092	4.016		.109	.281		.250	.656	15000
USC-437	4.375	4-3/8	111.1	4.191			.092	4.141	+ .000	.109	.281		.250	.656	15500
USC-450	4.500	4 1/2	114.3	4.310			.095	4.255	- .093	.109	.312		.250	.656	16200
USC-475	4.750	4-3/4	120.6	4.550			.100	4.495		.109	.312		.250	.656	16480
USC-500	5.000	5	127.0	4.790			.105	4.730		.109	.312		.250	.656	17110
USC-525	5.250	5-1/4	133.3	5.030			.110	4.970		.125	.375	+/- .005	.250	.750	20590
USC-550	5.500	5-1/2	139.7	5.266		.139	.117	5.206		.125	.375		.250	.750	21790
USC-575	5.750	5-3/4	146.0	5.506		+ .006	.122	5.446		.125	.375		.250	.750	23010
USC-590	5.900	-	149.9	5.656		- .000	.122	5.600	+ .000	.125	.375		.250	.750	23625
USC-600	6.000	6	152.4	5.746			.127	5.687	- .125	.125	.375		.250	.750	24000
USC-625	6.250	6-1/4	158.7	5.986			.132	5.916		.156	.437		.250	.750	30310
USC-650	6.500	6-1/2	165.1	6.226		.174	.137	6.151		.156	.437		.250	.750	33760
USC-675	6.750	6-3/4	171.4	6.466		+ .008	.142	6.386		.156	.437		.250	.750	36840
USC-700	7.000	7	177.8	6.706		- .000	.147	6.621		.156	.437		.250	.750	39920
USC-725	7.250	7-1/4	184.2	6.930			.160	6.840		.187	.500		.250	.875	43100
USC-750	7.500	7-1/2	190.5	7.180	+/- .008		.160	7.090		.187	.500		.250	.875	44500
USC-800	8.000	8	203.2	7.660		.209	.170	7.560		.187	.500		.250	.875	45500
USC-850	8.500	8-1/2	215.9	8.160		+ .008	.170	8.050	+ .000	.187	.500		.250	.875	46700
USC-900	9.000	9	228.6	8.660		- .000	.170	8.545	- .156	.187	.500		.250	.875	49900
USC-925	9.250	9-1/4	234.9	8.910			.170	8.800		.187	.500		.250	.875	51000
USC-950	9.500	9-1/2	241.3	9.160			.170	9.040		.187	.500		.250	.875	52590
USC-1000	10.000	10	254.0	9.660			.170	9.535		.187	.500		.250	.875	55600

Hardness: All ring sizes - HRC 42-53



# USH Constant Section

## Snap Ring, External Notched, Inch

Once installed in the groove of a shaft the portion of the ring protruding from the groove holds an assembly in place.

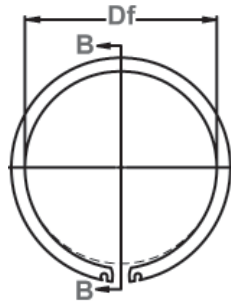

Free Diameter & Ring Measurements

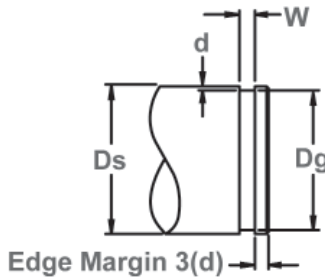

Shaft Diameter & Groove Dimensions

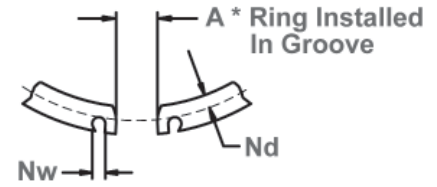

Material: SAE 1060-1075

RING SIZE	SHAFT DIAMETER			GROOVE SIZE			RING DIMENSIONS					ALLOWABLE STATIC THRUST LOAD (Lbs.)		
				DIAMETER	WIDTH	DEPTH	FREE DIAMETER	THICKNESS	SECTION	GAP	NOTCH DIMENSIONS			
	Ds DEC	Ds FRACT.	Ds mm	Dg +/- .006	W +.005/- .000	d	Df	TOL.	T +/- .002	S +/- .005	A* +/- .1/16		DEPTH Nd +0/- .030	WIDTH Nw REF
USH-206	2.062	2-1/16	52.4	1.946	.086	.058	1.926	+ .000 - .060	.078	.187	.375	.093	.125	5400
USH-212	2.125	2-1/8	54.0	2.003	.086	.061	1.983		.078	.187	.375	.093	.125	5530
USH-215	2.156	2-5/32	54.8	2.032	.086	.062	2.012		.078	.187	.375	.093	.125	5680
USH-225	2.250	2-1/4	57.1	2.120	.086	.065	2.100		.078	.203	.375	.100	.125	6200
USH-231	2.312	2-5/16	58.7	2.178	.086	.067	2.158		.078	.203	.375	.100	.125	6580
USH-237	2.375	2-3/8	60.3	2.239	.086	.068	2.219		.078	.203	.375	.100	.125	6870
USH-243	2.438	2-7/16	61.9	2.299	.086	.069	2.279		.078	.203	.375	.100	.125	7130
USH-250	2.500	2-1/2	63.5	2.360	.086	.070	2.340		.078	.218	.375	.110	.125	7430
USH-255	2.559	-	65.0	2.419	.086	.070	2.399		.078	.218	.375	.110	.125	7590
USH-262	2.625	2-5/8	66.7	2.481	.086	.072	2.461		.078	.218	.375	.110	.125	8020
USH-268	2.688	2-11/16	68.3	2.541	.103	.073	2.521	+ .000 - .080	.078	.218	.375	.110	.125	8320
USH-275	2.750	2-3/4	69.8	2.602	.103	.074	2.577		.093	.218	.500	.110	.125	8650
USH-287	2.875	2-7/8	73.0	2.721	.103	.077	2.696		.093	.218	.500	.110	.125	9330
USH-293	2.938	2-15/16	74.6	2.779	.103	.079	2.754		.093	.218	.500	.110	.125	9840
USH-300	3.000	3	76.2	2.838	.103	.081	2.813		.093	.218	.500	.110	.125	10310
USH-306	3.062	3-1/16	77.8	2.898	.103	.082	2.873		.093	.218	.500	.110	.125	10530
USH-312	3.125	3-1/8	79.4	2.957	.103	.084	2.932		.093	.218	.500	.110	.125	11170
USH-315	3.156	3-5/32	80.2	2.986	.103	.085	2.961		.093	.250	.500	.125	.125	11370
USH-325	3.250	3-1/4	82.5	3.076	.103	.087	3.051		.093	.250	.500	.125	.125	12000
USH-334	3.346	3-11/32	85.0	3.166	.103	.090	3.141		.093	.250	.500	.125	.125	12810
USH-343	3.438	3-7/16	87.3	3.257	.103	.090	3.232	.093	.250	.500	.125	.125	13100	
USH-350	3.500	3-1/2	88.9	3.316	.120	.092	3.286	.109	.250	.500	.125	.125	13640	
USH-354	3.543	-	90.0	3.357	.120	.093	3.327	.109	.250	.500	.125	.125	14000	
USH-362	3.625	3-5/8	92.1	3.435	.120	.095	3.405	.109	.250	.500	.125	.125	14580	
USH-368	3.688	3-11/16	93.7	3.493	.120	.097	3.463	.109	.250	.500	.125	.125	14650	
USH-375	3.750	3-3/4	95.2	3.552	.120	.099	3.522	.109	.281	.562	.150	.125	15800	
USH-387	3.875	3-7/8	98.4	3.673	.120	.101	3.643	.109	.281	.562	.150	.125	16600	
USH-393	3.938	3-15/16	100.0	3.734	.120	.102	3.704	.109	.281	.562	.150	.125	17040	
USH-400	4.000	4	101.6	3.792	.120	.104	3.762	+ .000 - .093	.109	.281	.562	.150	.125	17640
USH-425	4.250	4-1/4	108.0	4.065	.120	.092	4.025		.109	.281	.625	.150	.125	16600
USH-437	4.375	4-3/8	111.1	4.190	.120	.092	4.150		.109	.281	.625	.150	.125	17100
USH-450	4.500	4-1/2	114.3	4.310	.120	.095	4.270		.109	.312	.625	.180	.125	18230
USH-475	4.750	4-3/4	120.6	4.550	.120	.100	4.510		.109	.312	.625	.180	.125	19160
USH-500	5.000	5	127.0	4.790	.120	.105	4.750		.109	.312	.625	.180	.125	22280

\*Installed In Groove.

Hardness: All Ring Sizes - HRC 47-53

For alternate cutoff styles, contact Rotor Clip Technical Sales at +1.732.469.7333 (E-mail: tech@rotorclip.com)



# Snap Ring, External, Inch

A light-duty ring designed for needle bearings, once installed in the groove of a shaft the portion of the ring protruding from the groove holds an assembly in place.

# SNL Constant Section

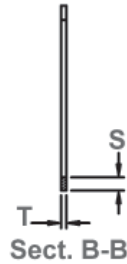
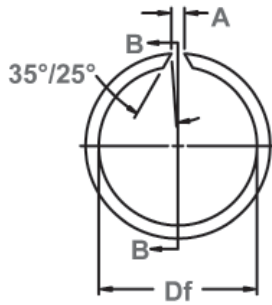

Free Diameter & Ring Measurements

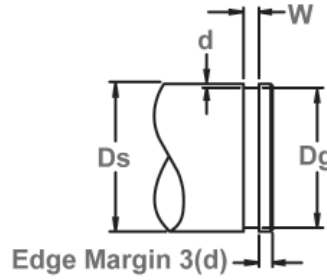

Edge Margin 3(d)

Shaft Diameter & Groove Dimensions

Material: SAE 1060-1075

RING SIZE	SHAFT DIAMETER			GROOVE SIZE						RING DIMENSIONS					ALLOWABLE STATIC THRUST LOAD (Lbs.)
				DIAMETER		WIDTH	DEPTH	FREE DIAMETER		THICKNESS	SECTION		FREE GAP		
	Ds DEC	Ds FRACT.	Ds mm	Dg	TOL.	W	d	Df	TOL.	T ±.002	S	TOL.	A min	A Max	
SNL-50	.500	1/2	12.7	.474		.039	.013	.465	+.000	.035	.048		.062	.218	460
SNL-62	.625	5/8	15.88	.597	±.002	+.003 -.000	.014	.587	-.025	.035	.062		.062	.218	520
SNL-75	.750	3/4	19.05	.716			.017	.704		.042	.078	±.003	.062	.218	900
SNL-87	.875	7/8	22.23	.833			.021	.823		.042	.093		.125	.281	1100
SNL-100	1.000	1	25.40	.954	±.003		.023	.944		.042	.093		.125	.281	1200
SNL-112	1.125	1-1/8	25.58	1.077			.024	1.065		.042	.125		.125	.281	1600
SNL-118	1.187	1-3/16	30.15	1.135			.026	1.120	+.000	.042	.125		.125	.281	1700
SNL-125	1.250	1-1/4	31.75	1.194			.028	1.179	-.031	.042	.125		.125	.281	1800
SNL-131	1.312	1-5/16	33.32	1.252		.046	.030	1.232		.042	.125		.125	.281	1900
SNL-137	1.375	1-3/8	34.93	1.309		+.003	.033	1.289		.042	.125		.125	.281	2010
SNL-143	1.437	1-7/16	36.50	1.369	±.004	-.000	.034	1.349		.042	.125		.125	.281	2120
SNL-150	1.500	1-1/2	38.10	1.430			.035	1.410		.042	.125		.125	.281	2260
SNL-162	1.625	1-5/8	41.28	1.545			.040	1.520		.042	.156		.156	.437	2800
SNL-168	1.687	1 -11/16	42.85	1.607			.040	1.582		.042	.156		.156	.437	2900
SNL-175	1.750	1-3/4	44.45	1.670			.040	1.645		.042	.156		.156	.437	3000
SNL-193	1.937	1-15/16	49.20	1.857			.040	1.832	+.000	.042	.156	±.005	.156	.437	3100
SNL-200	2.000	2	50.80	1.920			.040	1.895	-.062	.042	.156		.156	.437	3200
SNL-218	2.187	2-3/16	55.55	2.107			.040	2.082		.042	.156		.156	.437	3400
SNL-225	2.250	2-1/4	57.15	2.170			.040	2.145		.042	.156		.156	.437	3500
SNL-237	2.375	2-3/8	60.33	2.295			.040	2.270		.042	.156		.156	.437	3600
SNL-250	2.500	2-1/2	63.50	2.420			.040	2.390		.042	.156		.156	.437	3650
SNL-275	2.750	2-3/4	69.85	2.626			.062	2.596		.062	.187		.156	.468	5790
SNL-293	2.937	2-15/16	74.60	2.813			.062	2.783		.062	.187		.156	.468	6150
SNL-300	3.000	3	76.20	2.876	±.006	.068	.062	2.846	+.000	.062	.187		.156	.468	6250
SNL-312	3.125	3-1/8	79.38	3.000		+.004	.062	2.965	-.078	.062	.187		.156	.468	6400
SNL-325	3.250	3-1/4	82.55	3.125		-.000	.062	3.090		.062	.187		.156	.468	6500
SNL-337	3.375	3-3/8	85.73	3.250			.062	3.215		.062	.187		.156	.468	6600
SNL-350	3.500	3-1/2	88.90	3.375			.062	3.340		.062	.187		.156	.468	6700
SNL-375	3.750	3-3/4	95.25	3.610			.070	3.570		.078	.218		.187	.562	8800
SNL-400	4.000	4	101.60	3.860		.086	.070	3.820		.078	.218		.187	.562	9000
SNL-425	4.250	4-1/4	107.95	4.110		+.005	.070	4.070	+.000	.078	.218		.187	.562	9200
SNL-450	4.500	4-1/2	114.30	4.360		-.000	.070	4.320	-.093	.078	.218		.187	.562	9400
SNL-475	4.750	4-3/4	120.65	4.610			.070	4.560		.078	.218		.187	.562	9200
SNL-500	5.000	5	127.00	4.860			.070	4.800		.078	.218		.187	.562	9000
SNL-550	5.500	5-1/2	139.70	5.340		.103	.080	5.280		.093	.250		.218	.750	13000
SNL-600	6.000	6	152.40	5.840		+.005	.080	5.775	+.000	.093	.250		.218	.750	9000
SNL-650	6.500	6-1/2	165.10	6.340		-.000	.080	6.270	-.125	.093	.250		.218	.750	7500
SNL-700	7.000	7	177.80	6.840	±.008		.080	6.765		.093	.250		.218	.750	6100
SNL-750	7.500	7-1/2	190.50	7.320		.120	.090	7.245	+.000	.109	.281		.218	.812	
SNL-800	8.000	8	203.24	7.820		+.005 -.000'	.090	7.740	-.156	.109	.281		.218	.812	

Hardness: All Ring Sizes - HRC 42-52

For alternate cutoff styles, contact Rotor Clip Technical Sales at +1.732.469.7333 (E-mail: tech@rotorclip.com)



For the most up-to-date specifications, online ordering, quotations & sample orders, visit [www.rotorclip.com](http://www.rotorclip.com)



# SLC/SLO SHC/SHO Constant Section

## Snap Ring, External, Inch Square Section.

Once installed in the groove of a shaft the portion of the ring protruding from the groove holds an assembly in place.

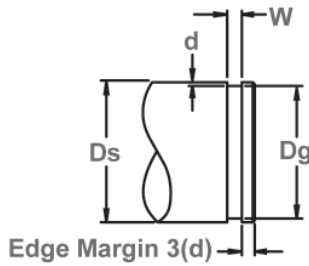

Shaft Diameter & Groove Dimensions

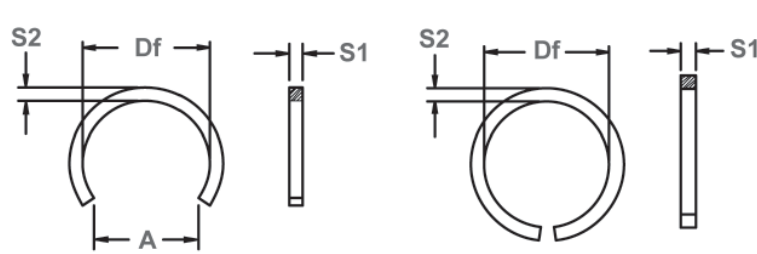

Free Diameter & Ring Measurements

Material: SAE 1060-1075

RING NUMBER		SHAFT DIAMETER		GROOVE DIMENSIONS					RING DIMENSIONS				
				DIAMETER		WIDTH	DEPTH	FREE DIAMETER		SECTION			FREE GAP
CLOSED*	OPEN*	Ds DEC	Ds mm	Dg	TOL.	W ±.002	d	Df	TOL.	S1	TOL.	S2 ±.005	A Max.
SHC-25	SHO-25	.250	6.35	.234	+.003 -.000	.036	.008	.230	+.000 -.020	.031	±.002	.031	.210
SLC-31	SLO-31	.312	7.92	.296		.036	.008	.290		.031		.031	.260
SHC-31	SHO-31	.312	7.92	.292		.045	.010	.287		.039		.039	.260
SLC-37	SLO-37	.375	9.53	.357		.041	.009	.350		.035		.035	.315
SHC-37	SHO-37	.375	9.53	.351		.052	.012	.344		.046		.046	.310
SLC-43	SLO-43	.437	11.10	.417		.045	.001	.410		.039		.039	.370
SHC-43	SHO-43	.437	11.10	.409		.062	.014	.403		.055		.055	.360
SLC-50	SLO-50	.500	12.70	.476		.052	.012	.469		.046		.046	.420
SHC-50	SHO-50	.500	12.70	.468		.069	.016	.461		.062		.062	.410
SLC-56	SLO-56	.562	14.27	.530		.069	.016	.523		.062		.062	.470
SHC-56	SHO-56	.562	14.27	.526	.078	.018	.519	.071	.071	.465			
SLC-62	SLO-62	.625	15.88	.597	.062	.014	.590	.055	.055	.525			
SHC-62	SHO-62	.625	15.88	.585	.085	.020	.578	.078	.078	.515			
SLC-68	SLO-68	.687	17.45	.659	.062	.014	.652	.055	.055	.580			
SHC-68	SHO-68	.687	17.45	.647	.085	.020	.640	.078	.078	.570			
SLC-75	SLO-75	.750	19.05	.718	.069	.016	.711	.062	.062	.630			
SHC-75	SHO-75	.750	19.05	.704	.100	.023	.694	.093	.093	.625			
SLC-81	SLO-81	.812	20.62	.780	.069	.016	.773	.062	.062	.690			
SHC-81	SHO-81	.812	20.62	.766	.100	.023	.759	.093	.093	.675			
SLC-87	SLO-87	.875	22.23	.839	.078	.018	.831	.071	.071	.735			
SHC-87	SHO-87	.875	22.23	.821	.117	.027	.813	.109	.109	.725			
SLC-93	SLO-93	.937	23.80	.901	.078	.018	.893	.071	.071	.790			
SHC-93	SHO-93	.937	23.80	.883	.117	.027	.875	.109	.109	.775			
SLC-100	SLO-100	1.000	25.40	.960	.085	.020	.950	.078	.078	.850			
SHC-100	SHO-100	1.000	25.40	.938	.133	.031	.928	.125	.125	.825			
SLC-106	SLO-106	1.062	26.97	1.022	.085	.020	1.012	.078	.078	.895			
SHC-106	SHO-106	1.062	26.97	1.000	.133	.031	.990	.125	.125	.880			
SLC-112	SLO-112	1.125	28.58	1.079	.100	.023	1.068	.093	.093	.950			
SHC-112	SHO-112	1.125	28.58	1.055	.148	.035	1.044	.140	.140	.930			
SLC-118	SLO-118	1.187	30.15	1.141	.100	.023	1.130	.093	.093	1.000			
SHC-118	SHO-118	1.187	30.15	1.117	.148	.035	1.106	.140	.140	.980			
SLC-125	SLO-125	1.250	31.75	1.196	.117	.027	1.184	.109	.109	1.050			
SHC-125	SHO-125	1.250	31.75	1.172	.164	.039	1.160	.156	±.003	.156	1.030		
SLC-131	SLO-131	1.312	33.32	1.258	.117	.027	1.246	.109	±.002	.109	1.100		
SHC-131	SHO-131	1.312	33.32	1.234	.164	.039	1.222	.156	±.003	.156	1.085		
SLC-137	SLO-137	1.375	34.93	1.315	.128	.030	1.304	.120	±.002	.120	1.150		
SHC-137	SHO-137	1.375	34.93	1.289	.180	.043	1.276	.172	±.003	.172	1.125		
SLC-143	SLO-143	1.437	36.50	1.377	.128	.030	1.364	.120	±.002	.120	1.205		
SHC-143	SHO-143	1.437	36.50	1.351	.180	.043	1.338	.172	±.003	.172	1.180		
SLC-150	SLO-150	1.500	38.10	1.438	.133	.031	1.424	.125	±.002	.125	1.260		
SHC-150	SHO-150	1.500	38.10	1.406	.195	.047	1.392	.187	±.003	.187	1.245		
SLC-162	SLO-162	1.625	41.28	1.563	.133	.031	1.547	.125	±.002	.125	1.375		
SHC-162	SHO-162	1.625	41.28	1.531	.195	.047	1.516	.187	±.003	.187	1.350		
SLC-175	SLO-175	1.750	44.45	1.672	.164	.039	1.657	.156	±.003	.156	1.475		

\*NOTE: H=HEAVY; L=LIGHT  
Hardness: All Ring Sizes - 46-53



# Snap Ring, External, Inch Round Section.

Once installed in the groove of a shaft the portion of the ring protruding from the groove holds an assembly in place.

# RLC/RLO RHC/RHO Constant Section

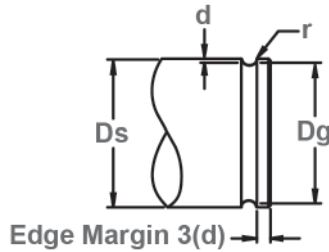

Shaft Diameter & Groove Dimensions

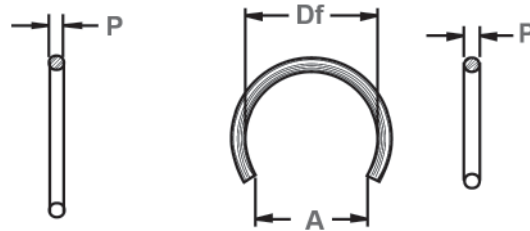

Free Diameter & Ring Measurement

RING NUMBER		SHAFT DIAMETER		GROOVE SIZE			RING DIMENSIONS						
				DIAMETER		RADIUS	DEPTH	FREE DIAMETER		SECTION	FREE GAP		
CLOSED*	OPEN*	Ds DEC	Ds mm	Dg	TOL.	r +.002/-0.000	d	Df	TOL.	P	A Max.		
RHC-25	RHO-25	.250	6.35	.234	+.003 -.000	.016	.008	.228	-.020	.029	.205		
RHC-31	RHO-31	.312	7.92	.290		.019	.011	.284		.035	.255		
RLC-37	RLO-37	.375	9.53	.357		.016	.009	.351		.029	.325		
RHC-37	RHO-37	.375	9.53	.349		.023	.013	.343		.043	.305		
RLC-43	RLO-43	.437	11.10	.415		.019	.011	.409		.035	.365		
RHC-43	RHO-43	.437	11.10	.405		.027	.016	.399		.051	.355		
RLC-50	RLO-50	.500	12.70	.474		.023	.013	.468		.043	.415		
RHC-50	RHO-50	.500	12.70	.464		.031	.018	.458		.059	.405		
RLC-56	RLO-56	.562	14.27	.534		.024	.014	.528		.045	.470		
RHC-56	RHO-56	.562	14.27	.524		.031	.019	.518		.059	.460		
RLC-62	RLO-62	.625	15.88	.593	+.000 -.025	.027	.016	.587	-.025	.051	.520		
RHC-62	RHO-62	.625	15.88	.581		.037	.022	.575		.071	.510		
RLC-68	RLO-68	.687	17.45	.655		.027	.016	.649		.051	.575		
RHC-68	RHO-68	.687	17.45	.643		.037	.022	.637		.071	.565		
RLC-75	RLO-75	.750	19.05	.714		.031	.018	.706		.059	.625		
RHC-75	RHO-75	.750	19.05	.698		.044	.026	.690		.085	.610		
RLC-81	RLO-81	.812	20.62	.776		.031	.018	.768		.059	.680		
RHC-81	RHO-81	.812	20.62	.760		.044	.026	.752		.085	.665		
RLC-87	RLO-87	.875	22.23	.831		.037	.022	.823		.071	.730		
RHC-87	RHO-87	.875	22.23	.813		.051	.031	.805		.100	.710		
RLC-93	RLO-93	.937	23.80	.893	+.000 -.035	.037	.022	.885	-.035	.071	.780		
RHC-93	RHO-93	.937	23.80	.875		.051	.031	.867		.100	.765		
RLC-100	RLO-100	1.000	25.40	.948		.044	.026	.938		.085	.830		
RHC-100	RHO-100	1.000	25.40	.926		.060	.037	.916		.118	.810		
RLC-106	RLO-106	1.062	26.97	1.010		.044	.026	1.000		.085	.885		
RHC-106	RHO-106	1.062	26.97	.988		.060	.037	.979		.118	.865		
RLC-112	RLO-112	1.125	28.58	1.063		±.003	.051	.031		1.051	+.000 -.046	.100	.930
RHC-112	RHO-112	1.125	28.58	1.045			.066	.040		1.034		.130	.915
RLC-118	RLO-118	1.187	30.15	1.125			.051	.031		1.114		.100	.985
RHC-118	RHO-118	1.187	30.15	1.107			.066	.040		1.096		.130	.970
RLC-125	RLO-125	1.250	31.75	1.176	.060		.037	1.164	.118	1.030			
RHC-125	RHO-125	1.250	31.75	1.162	.071		.044	1.150	.140	1.015			
RLC-131	RLO-131	1.312	33.32	1.238	.060		.037	1.226	.118	1.085			
RHC-131	RHO-131	1.312	33.32	1.224	.071		.044	1.212	.140	1.070			
RLC-137	RLO-137	1.375	34.93	1.295	.066		.040	1.281	.130	1.130			
RHC-137	RHO-137	1.375	34.93	1.277	.079		.049	1.263	.156	1.120			
RLC-143	RLO-143	1.437	36.50	1.357	.066	.040	1.344	.130	1.185				
RHC-143	RHO-143	1.437	36.50	1.339	.079	.049	1.326	.156	1.170				
RLC-150	RLO-150	1.500	38.10	1.412	+.000 -.062	.071	.044	1.398	-.062	.140	1.235		
RHC-150	RHO-150	1.500	38.10	1.392		.087	.054	1.378		.172	1.215		
RLC-162	RLO-162	1.625	41.28	1.537		.071	.044	1.522		.140	1.345		
RHC-162	RHO-162	1.625	41.28	1.517		.087	.054	1.502		.172	1.325		
RLC-175	RLO-175	1.750	44.45	1.642		.087	.054	1.626		.172	1.435		

\*NOTE: H=HEAVY; L=LIGHT  
Hardness: All Ring Sizes - HRC 46-53



# HBL/HBM/HBH Constant Section

## Snap Ring, Internal, Metric Designed for SAE Standard Metric Bearings.

Once installed in the groove of a housing/bore the portion of the ring protruding from the groove holds an assembly in place.

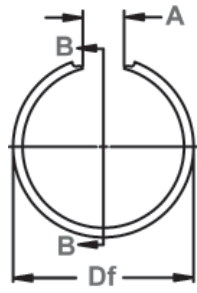

Free Diameter & Ring  
Measurement with Section B-B

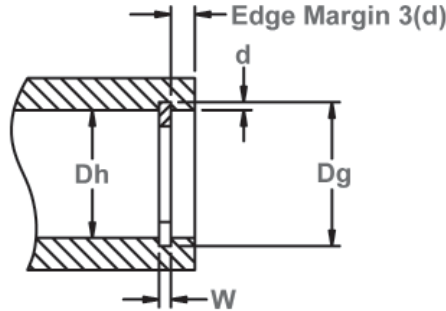
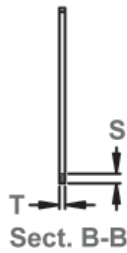

Housing Diameter &  
Groove Dimensions

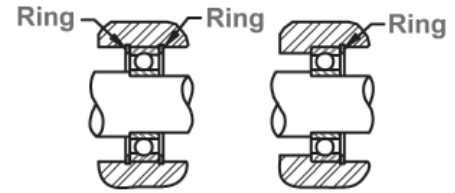

Ring Depicted retaining outer race of bearing in two directions (left) and in one direction (right).

Material: SAE 1060-1075

RING NUMBER	BEARING NUMBER			HOUSING DIAMETER		GROOVE SIZE					RING DIMENSIONS					GAP AT MIN. FREE O.D.
						DIAMETER		WIDTH		DEPTH	FREE DIAMETER		THICKNESS	SECTION		
	LIGHT	MED.	HEAVY	Dh DEC	Dh mm	Dg	TOL.	W	TOL.	d	Df	TOL.	T ±.002	S	TOL.	
HBL-30	200			1.1811	29.93	1.243	±.005	.035		.031	1.265	+.031 -.000	.031	.100	±.003	.375 +.080 -.000
HBM-30			1.1811	29.93	1.253	.046		.036		1.265	.042		.125	±.005		
HBH-30			1.1811	29.93	1.251	.068		.035		1.271	.062		.109	±.003		
HBL-32	201			1.2598	31.93	1.321	.035	.031	1.349	.031	.100	±.005				
HBM-32			1.2598	31.93	1.331	.046	.036	1.343	.042	.125	±.005					
HBH-32			1.2598	31.93	1.329	.068	.035	1.365	.062	.109	±.003					
HBL-35	202			1.3780	34.92	1.440	.035	.031	1.468	.031	.100	±.005				
HBM-35		300	1.3780	34.92	1.450	.046	.036	1.468	.042	.125	±.005					
HBH-35			1.3780	34.92	1.458	.068	.040	1.486	.062	.140	±.005					
HBL-37				1.4567	36.92	1.518	±.005	.035		.031	1.546		.031	.100	±.003	
HBM-37		301	1.4567	36.92	1.528	.046		.036		1.546	.042		.125	±.005		
HBH-37			1.4567	36.92	1.536	.068		.040		1.564	.062		.140	±.005		
HBL-40	203			1.5748	39.91	1.654	±.005	.046		.040	1.687	+.046 -.000	.042	.125	±.005	
HBM-40			1.5748	39.91	1.668	.046		.047		1.703	.042		.156	±.005		
HBH-40			1.5748	39.91	1.668	.068		.047		1.703	.062		.156	±.005		
HBL-42				1.6535	41.90	1.733	±.005	.046		.040	1.765		.042	.125	±.005	
HBM-42		302	1.6535	41.90	1.747	.046		.047		1.781	.042		.156	±.005		
HBH-42			1.6535	41.90	1.747	.062		.047		1.781	.062		.156	±.005		
HBL-47	204			1.8504	46.89	1.930	±.005	.046		.040	1.968	+.062 -.000	.042	.125	±.005	
HBM-47		303	1.8504	46.89	1.944	.046		.047		1.968	.042		.156	±.005		
HBH-47			1.8504	46.89	1.951	.068		.050		1.976	.062		.172	±.005		
HBL-52	205			2.0472	51.88	2.137	±.005	.046	+.004 -.000	.045	2.171		.042	.156	±.005	
HBM-52		304	2.0472	51.88	2.141	.046		.047		2.171	.042		.156	±.005		
HBH-52			2.0472	51.88	2.148	.068		.050		2.179	.062		.172	±.005		
HBL-62	206			2.4409	61.86	2.530	±.006	.068		.045	2.562		.062	.156	±.005	
HBM-62		305	2.4409	61.86	2.544	.068		.052		2.562	.062		.156	±.005		
HBH-62		403	2.4409	61.86	2.565	.103		.062		2.593	.093		.187	±.005		
HBL-72	207			2.8346	71.83	2.934	±.006	.068		.050	2.968		.062	.156	±.005	
HBM-72		306	2.8346	71.83	2.959	.068		.062		2.984	.062		.187	±.005		
HBH-72		404	2.8346	71.83	2.959	.103		.062		3.000	.093		.187	±.005		
HBL-80	208			3.1496	79.82	3.249	±.006	.068		.050	3.281	+.062 -.000	.062	.156	±.005	
HBM-80		307	3.1496	79.82	3.274	.068		.062		3.296	.062		.187	±.005		
HBH-80		405	3.1496	79.82	3.274	.103		.062		3.312	.093		.218	±.005		
HBL-85	209			3.3465	84.81	3.446	±.006	.068		.050	3.484		.062	.156	±.005	
HBM-85			3.3465	84.81	3.471	.068		.062		3.500	.062		.187	±.005		
HBH-85			3.3465	84.81	3.471	.103		.062		3.500	.093		.218	±.005		

Hardness: All Ring Sizes - HRC 42-52

For alternate cutoff styles, contact Rotor Clip Technical Sales at +1.732.469.7333 (E-mail: tech@rotorclip.com)



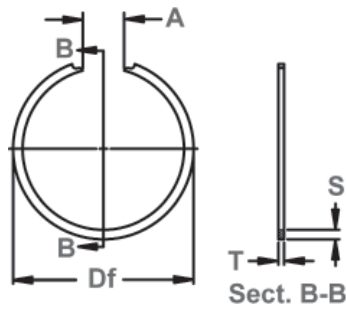

Free Diameter & Ring  
Measurement with Section B-B

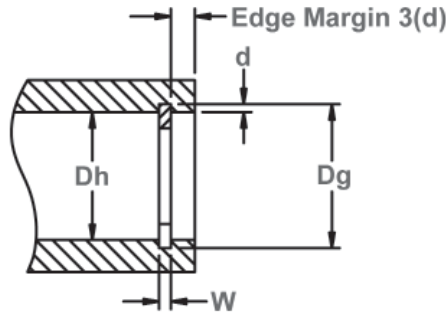

Housing Diameter &  
Groove Dimensions

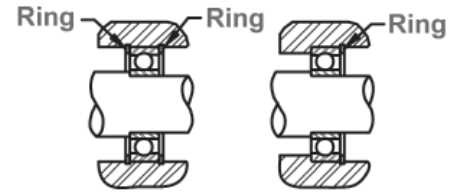

Ring Depicted retaining outer race of bearing in two directions (left) and in one direction (right).

Material: SAE 1060-1075

RING NUMBER	BEARING NUMBER			HOUSING DIAMETER		GROOVE SIZE						RING DIMENSIONS				GAP AT MIN. FREE O.D.
						DIAMETER		WIDTH		DEPTH	FREE DIAMETER		THICKNESS	SECTION		
	LIGHT	MED.	HEAVY	Dh DEC	Dh mm	Dg	TOL.	W	TOL.	d	Df	TOL.	T ±.002	S	TOL.	
HBL-90	210			3.5433	89.79	3.643		.103		.050	3.687		.093	.156	.687 +.093 -.000	
HBM-90		308		3.5433	89.79	3.668		.103		.062	3.703		.093	.187		
HBH-90			406	3.5433	89.79	3.713		.139		.085	3.750		.125	.250		
HBL-100	211			3.9370	100.00	4.062	±.006	.103		.062	4.093	+.093 -.000	.093	.187		
HBM-100		309		3.9370	100.00	4.107		.103		.085	4.140		.093	.250		
HBH-100			407	3.9370	100.00	4.107		.139		.085	4.140		.125	.250		
HBL-110	212			4.3307	110.00	4.455		.103		.062	4.500		.093	.187		
HBM-110		310		4.3307	110.00	4.500		.103		.085	4.531		.093	.250		
HBH-110			408	4.3307	110.00	4.500		.139		.085	4.531		.125	.250		
HBL-120	213			4.7244	120.00	4.884		.120		.080	4.937		.109	.250		
HBM-120		311		4.7244	120.00	4.912		.120		.094	4.953		.109	.281		
HBH-120			409	4.7244	120.00	4.894		.139		.085	4.937		.125	.250		
HBL-125	214			4.9213	125.00	5.081		.120	+.004 -.000	.080	5.125		.109	.250		
HBM-125				4.9213	125.00	5.109		.120			.094	5.156		.109	.281	
HBH-125				4.9213	125.00	5.121		.174			.100	5.151		.156	.312	
HBL-130	215			5.1181	130.00	5.278		.120		.080	5.312		.109	.250		
HBM-130		312		5.1181	130.00	5.306		.120		.094	5.343		.109	.281		
HBH-130			410	5.1181	130.00	5.318		.174		.100	5.355		.156	.312		
HBL-140	216			5.5118	140.00	5.671		.120	±.007	.080	5.703	+.125 -.000	.109	.250		
HBM-140		313		5.5118	140.00	5.699		.120			.094		5.750		.109	.281
HBH-140			411	5.5118	140.00	5.711		.174			.100		5.750		.156	.312
HBL-150	217			5.9055	150.00	6.065		.120			.080		6.093		.109	.250
HBM-150		314		5.9055	150.00	6.093		.120			.094		6.125		.109	.281
HBH-150			412	5.9055	150.00	6.105		.174			.100		6.156		.156	.312
HBL-160	218			6.2992	160.00	6.459		.120			.080		6.500		.109	.250
HBM-160		315		6.2992	160.00	6.497		.120			.094		6.550		.109	.281
HBH-160			413	6.2992	160.00	6.500		.174		.100	6.550		.156	.312		
HBL-170	219			6.6929	170.00	6.892		.139	±.008	.100	6.937	+.187 -.000	.125	.312		
HBM-170		316		6.6929	170.00	6.942		.139			.125		6.982		.125	.375
HBH-170				6.6929	170.00	6.892		.174			.100		6.937		.156	.312
HBL-180	220			7.0866	180.00	7.286		.139			.100		7.343		.125	.312
HBM-180		317		7.0866	180.00	7.336		.139			.125		7.380		.125	.375
HBH-180			414	7.0866	180.00	7.336		.209			.125		7.381		.187	.375
HBL-190	221			7.4803	190.00	7.680		.139			.100		7.718		.125	.312
HBM-190		318		7.4803	190.00	7.730		.139			.125		7.781		.125	.375
HBH-190				7.4803	190.00	7.730		.209			.125		7.782		.187	.375
HBL-200	222			7.8740	200.00	8.074		.139			.100		8.125		.125	.312
HBM-200		319		7.8740	200.00	8.125		.139			.125		8.187		.125	.375
HBH-200			416	7.8740	200.00	8.125		.209			.125		8.187		.187	.375

Hardness: All Ring Sizes - HRC 42-52

For alternate cutoff styles, contact Rotor Clip Technical Sales at +1.732.469.7333 (E-mail: tech@rotorclip.com)



# SR Constant Section

## Snap Ring, External, Metric For Grooves in Outer Tracks of Ball or Roller Bearings.

Once installed in the groove of a shaft, the portion of the ring protruding from the groove holds an assembly in place.

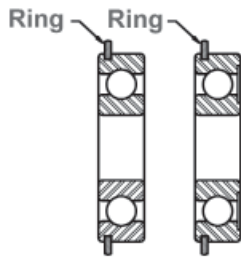

Open and shielded type bearings-  
Typical way of using retaining  
rings to retain bearings.

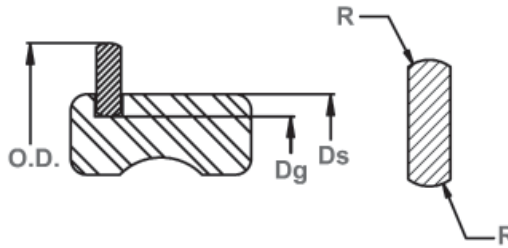

Shaft Diameter &  
Groove Dimensions

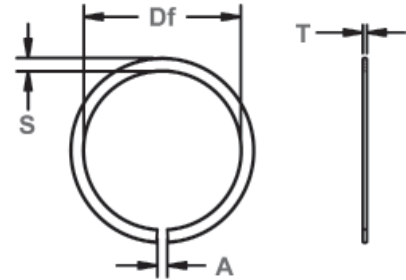

Free Diameter &  
Ring Measurement

Material: SAE 1065

RING NUMBER	SHAFT DIAMETER		BEARING NUMBER				GROOVE SIZE				RING DIMENSIONS						WEIGHT PER M (lbs.)	
							DIAMETER		ASSEMBLED O.D.	FREE DIAMETER		THICKNESS		SECTION		FREE GAP		Radius Max.
	Ds mm	Ds DEC.	EXTRA LIGHT	LIGHT	MED.	HEAVY	Dg	TOL.		Df	TOL.	T	TOL.	S	TOL.			A
SR-22	22	.8661	--	37-38	--	--	.8125		1.000	.799	+.000 -.015	.042		.094		1/8 Max.	.035	2.7
SR-30	30	1.1811	--	200	--	--	1.109		1.359	1.094		.042		.125		3/32±1/32	.035	5.6
SR-32	32	1.2598	102	201	--	--	1.187		1.437	1.172		.042		.125		3/32±1/32	.035	6.0
SR-35	35	1.3780	103	202	300	--	1.306		1.547	1.291	+.000	.042		.125		3/32±1/32	.035	6.6
SR-37	37	1.4567	--	--	301	--	1.369		1.609	1.354	-.020	.042		.125		3/32±1/32	.035	7.0
SR-40	40	1.5748	--	203	--	--	1.500		1.750	1.485		.042		.125		3/32±1/32	.035	7.8
SR-42	42	1.6535	104	--	302	--	1.565		1.812	1.550		.042		.125		3/32±1/32	.035	7.8
SR-47	47	1.8504	105	204	303	--	1.756		2.062	1.741		.042	.156		1/8±1/32	.035	11.0	
SR-52	52	2.0472	--	205	304	--	1.958		2.265	1.943		.042	.156		1/8±1/32	.035	12.1	
SR-55	55	2.1654	106	--	--	--	2.071		2.375	2.056	+.000	.042	.156		1/8±1/32	.035	12.8	
SR-62	62	2.4409	107	206	305	403	2.347		2.656	2.322	-.030	.065	.156		1/8±1/32	.050	21.9	
SR-68	68	2.6772	108	--	--	--	2.552		2.922	2.527		.065	.188		1/8±1/32	.050	29.1	
SR-72	72	2.8346	--	207	306	404	2.709		3.078	2.684		.065	.188		1/8±1/32	.050	30.8	
SR-75	75	2.9528	109	--	--	--	2.828		3.203	2.803		.065	.188		1/8±1/32	.050	32.1	
SR-80	80	3.1496	110	208	307	405	3.024		3.406	2.999		.065	.188		5/32±3/64	.050	34.2	
SR-85	85	3.3465	--	209	--	--	3.221		3.594	3.196	+.000	.065	.188		5/32±3/64	.050	36.7	
SR-90	90	3.5433	111	210	308	406	3.417		3.797	3.392	-.046	.095	±.002	.188	±.003	5/32±3/64	.060	56.5
SR-95	95	3.7402	112	--	--	--	3.615		3.984	3.590		.095	.188		5/32±3/64	.060	59.7	
SR-100	100	3.9370	113	211	309	407	3.811		4.187	3.786		.095	.188		5/32±3/64	.060	62.1	
SR-110	110	4.3307	114	212	310	408	4.205		4.578	4.180		.095	.188		3/16±1/16	.060	68.7	
SR-115	115	4.5276	115	--	--	--	4.402	±.003	4.781	4.377	+.000	.095	.188		3/16±1/16	.060	72.2	
SR-120	120	4.7244	--	213	311	409	4.536		5.094	4.506	-.062	.109	.281		3/16±1/16	.075	128.8	
SR-125	125	4.9213	116	214	--	--	4.733		5.297	4.703		.109	.281		3/16±1/16	.075	136.0	
SR-130	130	5.1181	117	215	312	410	4.930		5.500	4.900		.109	.281		3/16±1/16	.075	139.5	
SR-140	140	5.5118	118	216	313	411	5.324		5.890	5.294		.109	.281		9/32±1/16	.075	150.4	
SR-145	145	5.7087	119	--	--	--	5.521		6.078	5.491	+.000	.109	.281		9/32±1/16	.075	155.0	
SR-150	150	5.9055	120	217	314	412	5.718		6.281	5.688	-.093	.109	.281		9/32±1/16	.075	160.9	
SR-160	160	6.2992	121	218	315	413	6.111		6.672	6.081		.109	.281		9/32±1/16	.075	171.7	
SR-170	170	6.6929	122	219	316	--	6.443		7.187	6.413		.120	.375		3/8±1/16	.090	267.4	
SR-180	180	7.0866	124	220	317	414	6.837		7.594	6.807		.120	.375		3/8±1/16	.090	284.4	
SR-190	190	7.4803	--	221	318	415	7.230		7.984	7.200	+.000	.120	.375		3/8±1/16	.090	300.1	
SR-200	200	7.8740	126	222	319	416	7.624		8.375	7.594	-.125	.120	.375		3/8±1/16	.090	309.1	
SR-210	210	8.2677	128	--	--	417	8.018		8.766	7.987		.120	.375		3/8±1/16	.090	319.0	
SR-215	215	8.4646	--	224	320	--	8.215		8.969	8.184		.120	.375		3/8±1/16	.090	338.4	
SR-225	225	8.8583	130	--	321	418	8.6083		9.328	8.578	+.000	.120	.375		15/32±3/3	.090	349.0	
SR-230	230	9.0551	--	226	--	--	8.8051		9.562	8.775	-.156	.120	.375		15/32±3/3	.090	362.0	
SR-240	240	9.4488	132	--	322	--	9.1988		9.953	9.168		.120	.375		15/32±3/3	.090	375.4	

Hardness: All Ring Sizes - HRC 40-50

For alternate cutoff styles, contact Rotor Clip Technical Sales at +1.732.469.7333 (E-mail: tech@rotorclip.com)



# Snap Ring, External, Metric

For SAE Standard Metric Bearings.

Once installed in the groove of a shaft, the portion of the ring protruding from the groove holds an assembly in place.

# SB Constant Section

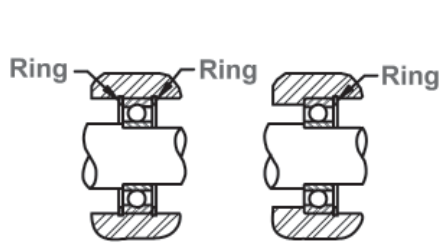

Drawing depicts using rings to retain bearings in a typical shaft application.

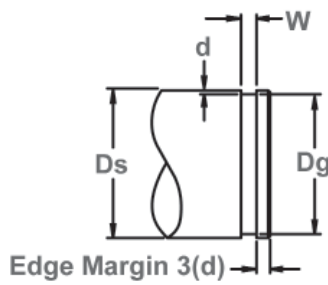

Shaft Diameter & Groove Dimensions

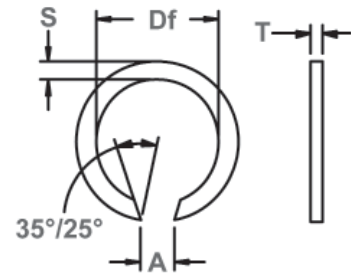

Free Diameter & Ring Measurements

RING NUMBER	SHAFT DIAMETER		BEARING NUMBER			GROOVE DIAMETER			RING DIMENSIONS								
	Ds DEC	Ds mm				DIAMETER		WIDTH	DEPTH	FREE DIAMETER	THICKNESS	SECTION	FREE GAP				
						Dg	TOL.	W	d	Df	Tol.	T ±.002	S	A Min.	A Max.		
SB-12	.4724	12.00	201	301	--	.436	±.002	.046 +.003 -.000	.018	.421	+ .000 -.020	.042	.062 ±.003	.062	.187		
SB-15	.5906	15.00	202	302	--	.550		.053	.020	.538	+ .000	.047	.078	.078	.218		
SB-17	.6693	17.00	203	303	403	.629		+ .004 -.000	.020	.616	-.025	.047	±.003	.078	.218		
SB-20	.7874	20.00	204	304	404	.731	±.004	.068	.028	.710	+ .000	.062	.093 ±.003	.078	.218		
SB-25	.9843	25.00	205	305	405	.924		+ .004 -.000	.030	.910		-.031	.062	.109 ±.003	.156	.312	
SB-30	1.1811	30.00	206	306	406	1.111		.085 +.004 -.000	.035	1.093			+ .000	.075	.125 ±.005	.156	.312
SB-35	1.3780	35.00	207	307	407	1.288	±.006	.108	.045	1.265	-.046			.093	.156	.250	.406
SB-40	1.5748	40.00	208	308	408	1.465		+ .005	.055	1.452		+ .000		.093	±.005	.250	.406
SB-45	1.7717	45.00	209	309	409	1.648		-.000	.062	1.625			+ .000	.093	.188	.250	.468
SB-50	1.9685	50.00	210	310	410	1.844	±.006	.062	1.820	-.062	.093			±.005	.250	.468	
SB-55	2.1654	55.00	211	311	411	2.015		.120	.075		1.995	+ .000		.109	.218	.250	.468
SB-60	2.3622	60.00	212	312	412	2.212		+ .005 -.000	.075		2.187		+ .000	.109	±.005	.250	.468
SB-65	2.5591	65.00	213	313	413	2.389	±.006	.139	.085	2.359	+ .000			.125	.250	.250	.468
SB-70	2.7559	70.00	214	314	414	2.586			.085	2.556		+ .000		.125		±.005	.250
SB-75	2.9528	75.00	215	315	415	2.783			.085	2.750			-.062	.125			.250
SB-80	3.1496	80.00	216	316	416	2.979	+ .006	.085	2.946	+ .000	.125			.250	.250		
SB-85	3.3465	85.00	217	317	417	3.176	-.000	.085	3.139		+ .000	.125			.250	.250	
SB-90	3.5433	90.00	218	318	418	3.343	±.006	.100	3.308			-.078	.125			.312	.312
SB-95	3.7402	95.00	219	319	419	3.540		.100	3.500	+ .000			.125	±.005			.312
SB-100	3.9370	100.00	220	320	420	3.737		.100	3.697		+ .000		.156		.312		.312
SB-105	4.1339	105.00	221	321	421	3.934	+ .008	.100	3.888			+ .000	.156			.312	.312
SB-110	4.3307	110.00	222	322	422	4.131	-.000	.100	4.080	-.093			.156	.312			.687

Hardness: All Ring Sizes - HRC 42-52

For alternate cutoff styles, contact Rotor Clip Technical Sales at +1.732.469.7333 (E-mail: tech@rotorclip.com)



For the most up-to-date specifications, online ordering, quotations & sample orders, visit [www.rotorclip.com](http://www.rotorclip.com)

# CFS Constant Section

## Snap Ring, External, Metric Flat Wire.

Once installed in the groove of a shaft, the portion of the ring protruding from the groove holds an assembly in place.

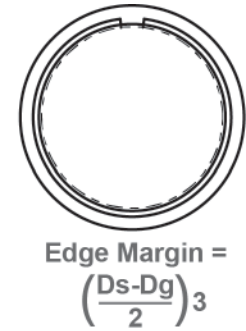
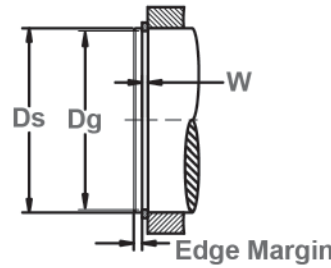
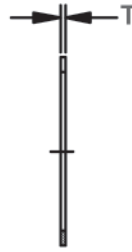
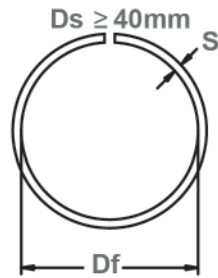
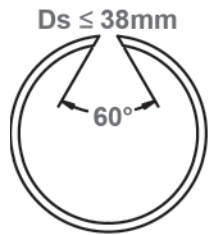

Free Diameter & Ring Dimensions

Shaft Diameter & Groove Dimensions

RING SIZE	SHAFT DIAMETER		GROOVE DIMENSIONS			RING DIMENSIONS & WEIGHT				SUPPLEMENTARY DATA			
	Ds DEC	Ds mm	DIAMETER		WIDTH	FREE DIAMETER	THICKNESS	SECTION	WEIGHT	Pg (kN)	Pr (kN)	R.P.M. X1000 (1/min)	
			Dg	TOL.	W min	Df max	T -0,1	S -0,1	kg/1000				
CFS-4	0.1575	4	3,8	-0,09	0,6	3,7	0,5	0,80	0,02	0,20	1,25	275,0	
CFS-5	0.1969	5	4,8		0,6	4,7	0,5	1,00	0,05	0,26	1,30	192,0	
CFS-6	0.2362	6	5,7		0,8	5,6	0,7	1,10	0,09	0,46	3,50	141,0	
CFS-7	0.2756	7	6,7		0,8	6,5	0,7	1,20	0,12	0,54	3,50	134,0	
CFS-8	0.3150	8	7,6		1,1	7,4	1,0	1,30	0,20	0,82	6,50	108,0	
CFS-9	0.3543	9	8,6		1,1	8,4	1,0	1,30	0,24	0,92	6,50	80,0	
CFS-10	0.3937	10	9,6		1,1	9,4	1,0	1,30	0,25	1,03	6,50	68,0	
CFS-11	0.4331	11	10,5		1,1	10,2	1,0	1,30	0,29	1,40	9,80	64,0	
CFS-12	0.4724	12	11,5		1,1	11,2	1,0	1,30	0,30	1,53	9,30	53,0	
CFS-13	0.5118	13	12,5		1,1	12,2	1,0	1,30	0,34	1,70	8,90	43,0	
CFS-14	0.5512	14	13,5	-0,11	1,3	13,1	1,2	1,50	0,50	1,80	17,00	45,0	
CFS-15	0.5906	15	14,4		1,3	14,0	1,2	1,75	0,66	2,30	18,70	44,0	
CFS-16	0.6299	16	15,4		1,3	15,0	1,2	1,75	0,69	2,47	17,70	38,0	
CFS-17	0.6693	17	16,4		1,3	16,0	1,2	1,75	0,72	2,63	17,00	34,0	
CFS-18	0.7087	18	17,4		1,3	17,0	1,2	1,75	0,75	2,78	16,20	30,0	
CFS-19	0.7480	19	18,4		1,3	17,9	1,2	1,75	0,80	2,94	15,60	29,0	
CFS-20	0.7874	20	19,2		1,3	18,7	1,2	1,75	0,84	4,10	15,00	26,0	
CFS-21	0.8268	21	20,2		1,3	19,7	1,2	1,75	0,87	4,30	14,60	23,0	
CFS-22	0.8661	22	21,2		1,3	20,7	1,2	1,75	0,91	4,50	14,00	21,0	
CFS-24	0.9449	24	23,0		-0,13	1,3	22,5	1,2	1,75	0,99	6,15	13,30	18,0
CFS-25	0.9843	25	24,0	1,3		23,5	1,2	1,75	1,00	6,40	12,80	16,0	
CFS-26	1.0236	26	25,0	1,3		24,5	1,2	1,75	1,10	6,65	12,50	15,0	
CFS-27	1.0630	27	26,0	1,6		25,5	1,5	2,30	2,00	6,95	30,00	16,0	
CFS-28	1.1024	28	27,0	1,6		26,5	1,5	2,30	2,11	7,20	29,30	15,0	
CFS-29	1.1417	29	28,0	1,6		27,5	1,5	2,30	2,20	7,45	28,20	14,0	
CFS-30	1.1811	30	29,0	1,6		28,5	1,5	2,30	2,33	7,70	27,50	13,0	
CFS-32	1.2598	32	30,8	-0,16		1,6	30,2	1,5	2,30	2,41	9,90	26,50	13,0
CFS-35	1.3780	35	33,8			1,6	33,2	1,5	2,30	2,51	10,80	24,40	11,0
CFS-37	1.4567	37	35,8			1,6	35,2	1,5	2,30	2,72	11,30	23,50	9,0
CFS-38	1.4961	38	36,8		1,6	36,2	1,5	2,30	2,83	11,60	22,70	9,0	
CFS-40	1.5748	40	38,5		1,6	37,8	1,5	2,30	2,91	15,50	22,00	8,0	
CFS-42	1.6535	42	40,5		1,6	39,8	1,5	2,30	3,10	16,20	21,40	7,0	
CFS-43	1.6929	43	41,5		1,6	40,8	1,5	2,30	3,25	16,50	21,10	7,0	

Hardness: Sizes 4-20, 47-52 HRC; Sizes 21 & Over, 45-50 HRC

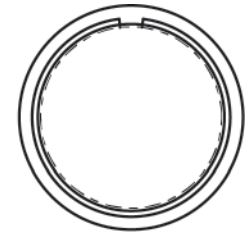
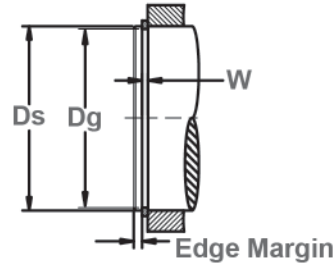
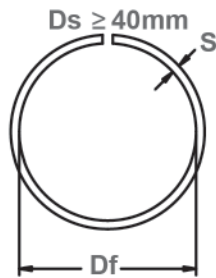
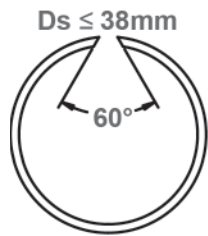

$$\text{Edge Margin} = \left(\frac{D_s - D_g}{2}\right)^3$$

Free Diameter & Ring Dimensions

Shaft Diameter & Groove Dimensions

RING SIZE	SHAFT DIAMETER		GROOVE DIMENSIONS		RING DIMENSIONS & WEIGHT					SUPPLEMENTARY DATA		
	Ds DEC	Ds mm	DIAMETER		WIDTH W min	FREE DIAMETER Df max	THICKNESS T -0,1	SECTION S -0,1	WEIGHT kg/1000	Pg (kN)	Pr (kN)	R.P.M. X1000 (1/min)
			Dg	TOL.								
CFS-45	1.7717	45	43,5	-0,16	1,6	42,8	1,5	2,30	3,39	17,30	20,60	6,0
CFS-47	1.8504	47	45,5	-0,16	1,6	44,8	1,5	2,30	3,48	18,20	19,20	6,0
CFS-48	1.8898	48	46,5	-0,16	1,6	45,8	1,5	2,30	3,60	18,70	18,60	5,0
CFS-50	1.9685	50	48,5	-0,16	1,6	47,8	1,5	2,30	3,73	19,50	18,10	5,0
CFS-52	2.0472	52	50,5	-0,16	1,6	49,8	1,5	2,30	3,92	20,20	17,70	4,0
CFS-55	2.1654	55	53,5	-0,16	1,6	52,6	1,5	2,30	4,11	21,00	16,50	4,0
CFS-58	2.2835	58	56,5	-0,16	1,6	55,6	1,5	2,30	4,40	22,50	15,70	4,0
CFS-60	2.3622	60	58,5	-0,19	1,6	57,6	1,5	2,30	4,55	23,20	15,40	4,0
CFS-63	2.4803	63	61,5	-0,19	1,6	60,6	1,5	2,30	4,58	24,40	14,70	3,0
CFS-65	2.5591	65	63,5	-0,19	1,6	62,6	1,5	2,30	4,64	25,20	14,20	3,0
CFS-68	2.6772	68	66,2	-0,19	2,2	65,4	2,0	2,80	8,59	31,70	39,60	3,0
CFS-70	2.7559	70	68,2	-0,19	2,2	67,4	2,0	2,80	8,71	32,50	38,40	3,0
CFS-72	2.8346	72	70,2	-0,19	2,2	69,4	2,0	2,80	8,80	33,70	37,60	3,0
CFS-73	2.8740	73	71,2	-0,19	2,2	70,4	2,0	2,80	8,90	34,00	37,00	3,0
CFS-75	2.9528	75	73,2	-0,19	2,2	72,4	2,0	2,80	9,32	35,00	36,20	2,0
CFS-80	3.1496	80	78,2	-0,19	2,2	77,4	2,0	2,80	9,67	37,40	34,20	2,0
CFS-85	3.3465	85	83,0	-0,22	2,7	82,0	2,5	3,40	16,00	44,00	72,00	2,0
CFS-90	3.5433	90	88,0	-0,22	2,7	87,0	2,5	3,40	16,00	46,50	66,30	2,0
CFS-95	3.7402	95	93,0	-0,22	2,7	92,0	2,5	3,40	18,20	49,20	61,80	2,0
CFS-100	3.9370	100	98,0	-0,22	2,7	97,0	2,5	3,40	18,90	51,90	57,30	2,0
CFS-105	4.1339	105	102,7	-0,22	2,7	101,7	2,5	3,40	20,70	65,00	54,00	2,0
CFS-110	4.3307	110	107,7	-0,22	2,7	106,6	2,5	3,40	20,90	69,00	50,40	1,0
CFS-115	4.5276	115	112,7	-0,22	2,7	111,6	2,5	3,40	22,10	71,00	47,20	1,0
CFS-120	4.7244	120	117,7	-0,22	2,7	116,5	2,5	3,40	24,10	75,00	44,80	1,0
CFS-125	4.9213	125	122,7	-0,25	2,7	121,5	2,5	3,40	25,10	78,50	41,80	1,0
CFS-130	5.1181	130	127,7	-0,25	2,7	126,4	2,5	3,40	26,60	84,00	39,60	1,0
CFS-135	5.3150	135	132,4	-0,25	2,7	131,1	2,5	4,00	30,20	87,00	44,00	1,0
CFS-140	5.5118	140	137,4	-0,25	2,7	136,0	2,5	4,00	31,10	91,50	41,60	1,0
CFS-145	5.7087	145	142,4	-0,25	2,7	141,0	2,5	4,00	32,60	95,00	39,60	1,0
CFS-150	5.9055	150	147,4	-0,25	2,7	145,9	2,5	4,00	32,80	98,00	37,50	1,0
CFS-155	6.1024	155	154,4	-0,25	2,7	150,9	2,5	4,00	34,70	100,00	36,30	1,0
CFS-160	6.2992	160	157,4	-0,25	2,7	155,8	2,5	4,00	36,60	103,00	35,60	1,0
CFS-165	6.4961	165	162,4	-0,25	2,7	160,8	2,5	4,00	37,40	106,00	34,20	0,5

Hardness: Sizes 4-20, 47-52 HRC; Sizes 21 & Over, 45-50 HRC

# CFS Constant Section

## Snap Ring, External, Metric Flat Wire.

Once installed in the groove of a shaft, the portion of the ring protruding from the groove holds an assembly in place.

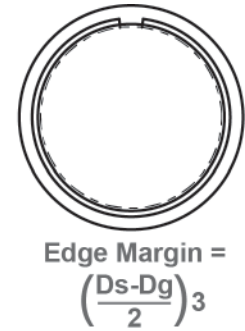
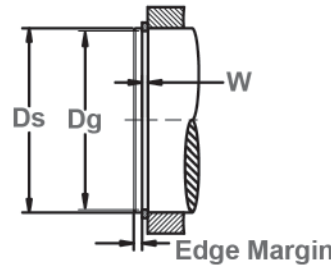
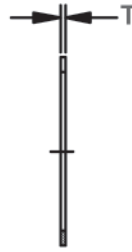
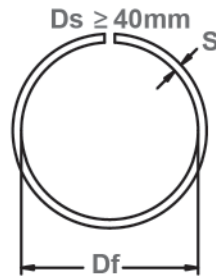
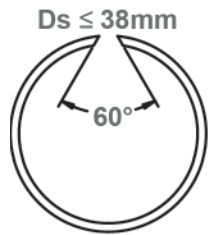

Free Diameter & Ring Dimensions

Shaft Diameter & Groove Dimensions

RING SIZE	SHAFT DIAMETER		GROOVE DIMENSIONS			RING DIMENSIONS & WEIGHT				SUPPLEMENTARY DATA			
			DIAMETER		WIDTH	FREE DIAMETER	THICKNESS	SECTION	WEIGHT	Pg (kN)	Pr (kN)	R.P.M. X1000 (1/min)	
	Ds DEC	Ds mm	Dg	TOL.	W min	Df max	T -0,1	S -0,1	kg/1000				
CFS-170	6.6929	170	167,4	-0,25	2,7	165,7	2,5	4,00	38,50	108,00	33,50	0,5	
CFS-175	6.8898	175	172,4		2,7	170,7	2,5	4,00	39,40	117,00	32,20	0,4	
CFS-180	7.0866	180	177,0		3,2	175,2	3,0	5,00	61,20	140,00	67,50	1,0	
CFS-185	7.2835	185	182,0	-0,29	3,2	180,2	3,0	5,00	63,90	144,00	66,20	1,0	
CFS-190	7.4803	190	187,0		3,2	185,1	3,0	5,00	65,90	148,00	64,00	1,0	
CFS-195	7.6772	195	192,0		3,2	190,1	3,0	5,00	67,50	152,00	62,60	1,0	
CFS-200	7.8740	200	197,0		3,2	196,0	3,0	5,00	68,40	156,00	61,40	0,5	
CFS-210	8.2677	210	207,0		3,2	204,9	3,0	5,00	72,00	164,00	58,00	0,5	
CFS-220	8.6614	220	217,0		3,2	214,8	3,0	5,00	76,30	171,00	55,50	0,4	
CFS-230	9.0551	230	227,0		3,2	224,7	3,0	5,00	79,80	180,00	53,00	0,3	
CFS-240	9.4488	240	237,0		3,2	234,6	3,0	5,00	81,70	187,00	51,00	0,3	
CFS-250	9.8425	250	247,0		-0,32	3,2	244,5	3,0	5,00	86,50	195,00	49,00	0,3
CFS-260	10.2362	260	255,0			4,2	252,4	4,0	7,50	179,00	338,00	168,00	0,4
CFS-265	10.4331	265	260,0	4,2		257,4	4,0	7,50	185,20	344,00	165,00	0,4	
CFS-270	10.6299	270	265,0	4,2		262,3	4,0	7,50	197,70	350,00	162,00	0,4	
CFS-280	11.0236	280	275,0	4,2		272,2	4,0	7,50	198,70	362,00	155,00	0,4	
CFS-285	11.2205	285	280,0	4,2		277,2	4,0	7,50	199,50	370,00	151,00	0,3	
CFS-290	11.4173	290	285,0	4,2		282,1	4,0	7,50	205,30	377,00	148,00	0,3	
CFS-300	11.8110	300	295,0	4,2		292,1	4,0	7,50	214,20	390,00	145,00	0,3	
CFS-305	12.0079	305	300,0	4,2		297,1	4,0	7,50	219,40	396,00	142,00	0,3	
CFS-310	12.2047	310	305,0	4,2		302,0	4,0	7,50	223,10	402,00	139,00	0,3	
CFS-320	12.5984	320	315,0	4,2	311,9	4,0	7,50	225,30	416,00	137,00	0,3		
CFS-330	12.9921	330	325,0	-0,36	4,2	321,8	4,0	7,50	228,60	428,00	132,00	0,2	
CFS-340	13.3858	340	335,0		4,2	331,7	4,0	7,50	239,30	442,00	129,00	0,2	
CFS-350	13.7795	350	345,0		4,2	341,6	4,0	7,50	251,20	455,00	123,00	0,2	
CFS-360	14.1732	360	355,0		4,2	351,5	4,0	7,50	253,10	468,00	120,00	0,2	
CFS-370	14.5669	370	365,0		4,2	361,5	4,0	7,50	259,20	482,00	117,00	0,2	
CFS-380	14.9606	380	375,0		4,2	371,4	4,0	7,50	265,80	494,00	115,00	0,2	
CFS-390	15.3543	390	385,0		4,2	381,3	4,0	7,50	273,90	507,00	112,00	0,2	
CFS-400	15.7480	400	395,0		4,2	391,2	4,0	7,50	281,10	521,00	109,00	0,1	
CFS-420	16.5354	420	415,0		4,8	410,0	4,5	12,00	531,00	547,00	133,00	0,3	
CFS-460	18.1102	460	455,0		4,8	449,5	4,5	12,00	582,00	600,00	126,00	0,2	

Hardness: Sizes 4-20, 47-52 HRC; Sizes 21 & Over, 45-50 HRC

# Snap Ring, Internal, Metric

## Flat Wire.

Once installed in the groove of a housing/bore, the portion of the ring protruding from the groove holds an assembly in place.

# CFH Constant Section

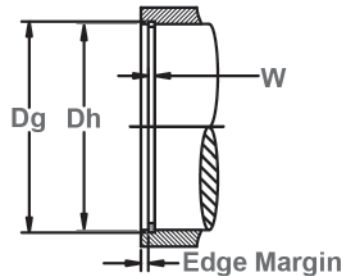
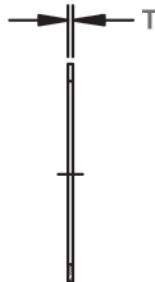
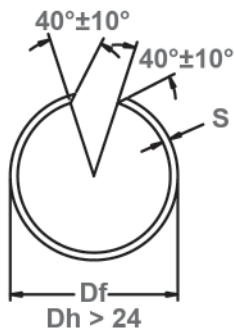
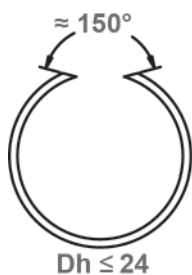

Free Diameter & Ring Dimensions

Housing Diameter & Groove Dimensions

RING SIZE	HOUSING DIAMETER		GROOVE DIMENSIONS			RING DIMENSIONS & WEIGHT				THRUST LOAD	
	Dh DEC	Dh mm	DIAMETER		WIDTH	FREE DIAMETER	THICKNESS	SECTION	WEIGHT kg/1000	Pg (kN)	Pr (kN)
			Dg	TOL.	W min	Df min	T -0,1	S -0,1			
CFH-7	0.2756	7	7,3	+0,09	0,9	7,5	0,8	1,00	0,09	0,55	3,30
CFH-8	0.3150	8	8,3		0,9	8,5	0,8	1,00	0,10	0,65	3,25
CFH-9	0.3543	9	9,3		0,9	9,5	0,8	1,10	0,13	0,70	3,20
CFH-10	0.3937	10	10,4		0,9	10,6	0,8	1,20	0,15	1,05	3,15
CFH-11	0.4331	11	11,4	+0,11	1,1	11,6	1,0	1,30	0,21	1,15	9,15
CFH-12	0.4724	12	12,4		1,1	12,7	1,0	1,30	0,25	1,30	8,90
CFH-13	0.5118	13	13,5		1,1	13,8	1,0	1,30	0,28	1,75	8,80
CFH-14	0.5512	14	14,5		1,1	14,8	1,0	1,30	0,31	1,90	8,20
CFH-15	0.5906	15	15,5		1,1	15,8	1,0	1,30	0,34	2,00	7,70
CFH-16	0.6299	16	16,5		1,3	16,8	1,2	1,75	0,53	2,10	15,50
CFH-17	0.6693	17	17,5		1,3	17,8	1,2	1,75	0,55	2,25	15,40
CFH-18	0.7087	18	18,5		1,3	18,9	1,2	1,75	0,68	2,40	15,10
CFH-19	0.7480	19	19,6	+0,13	1,3	19,9	1,2	1,75	0,72	3,00	14,80
CFH-20	0.7874	20	20,6		1,3	21,0	1,2	1,75	0,76	3,20	14,20
CFH-21	0.8268	21	21,6		1,3	22,0	1,2	1,75	0,79	3,35	13,70
CFH-22	0.8661	22	22,6		1,3	23,0	1,2	1,75	0,81	3,50	13,10
CFH-23	0.9055	23	23,6		1,3	24,0	1,2	1,75	0,88	3,65	12,80
CFH-24	0.9449	24	24,8		1,3	25,2	1,2	1,75	0,90	5,10	12,50
CFH-25	0.9843	25	25,8		1,3	26,2	1,2	1,75	0,91	5,30	12,00
CFH-26	1.0236	26	26,8		1,3	27,2	1,2	1,75	0,98	5,50	11,50
CFH-27	1.0630	27	27,8		1,3	28,2	1,2	1,75	1,11	5,70	11,30
CFH-28	1.1024	28	28,8		1,3	29,2	1,2	1,75	1,13	5,95	11,00
CFH-29	1.1417	29	29,8	+0,16	1,3	30,2	1,2	1,75	1,15	6,15	10,90
CFH-30	1.1811	30	31,0		1,6	31,4	1,5	2,30	2,00	8,00	26,00
CFH-31	1.2205	31	32,0		1,6	32,4	1,5	2,30	2,03	8,25	25,60
CFH-32	1.2598	32	33,0		1,6	33,4	1,5	2,30	2,11	8,50	25,00
CFH-33	1.2992	33	34,0		1,6	34,4	1,5	2,30	2,26	8,75	24,60
CFH-34	1.3386	34	35,0		1,6	35,4	1,5	2,30	2,34	9,00	23,80
CFH-35	1.3780	35	36,0		1,6	36,4	1,5	2,30	2,36	9,30	23,30
CFH-37	1.4567	37	38,2		1,6	38,8	1,5	2,30	2,53	11,75	22,00
CFH-38	1.4961	38	39,2		1,6	39,8	1,5	2,30	2,61	12,15	21,60
CFH-39	1.5354	39	40,2		1,6	40,8	1,5	2,30	2,67	12,40	21,00
CFH-40	1.5748	40	41,2	1,6	41,8	1,5	2,30	2,80	12,70	20,70	
CFH-42	1.6535	42	43,2	1,6	43,8	1,5	2,30	2,92	13,30	19,80	
CFH-43	1.6929	43	44,2	1,6	44,8	1,5	2,30	3,03	13,70	19,60	

Hardness: Sizes 7-20, 47-52HRC; Sizes 21 & Over, 45-50 HRC

# CFH Constant Section

## Snap Ring, Internal, Metric Flat Wire.

Once installed in the groove of a housing/bore, the portion of the ring protruding from the groove holds an assembly in place.

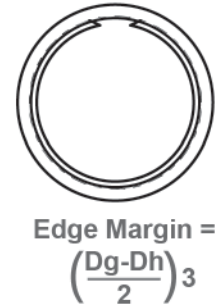
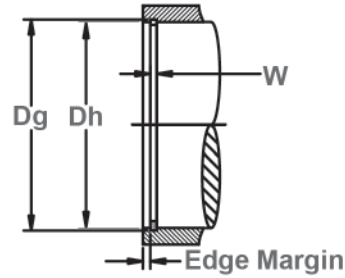
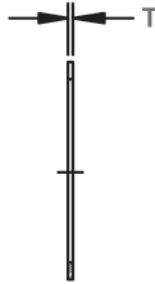
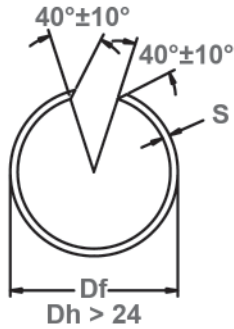
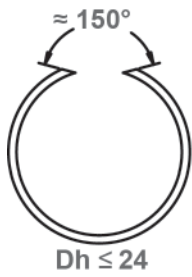

Free Diameter & Ring Dimensions

Housing Diameter & Groove Dimensions

RING SIZE	HOUSING DIAMETER		GROOVE DIMENSIONS			RING DIMENSIONS & WEIGHT				THRUST LOAD		
	Dh DEC	Dh mm	DIAMETER		WIDTH	FREE DIAMETER	THICKNESS	SECTION	WEIGHT	Pg (kN)	Pr (kN)	
			Dg	TOL.								kg/1000
CFH-44	1.7323	44	45,2	+0,16	1,6	45,8	1,5	2,30	3,11	14,00	19,30	
CFH-45	1.7717	45	46,2		1,6	46,8	1,5	2,30	3,25	14,25	19,00	
CFH-46	1.8110	46	47,2		1,6	47,8	1,5	2,30	3,28	14,65	18,40	
CFH-47	1.8504	47	48,2		1,6	48,8	1,5	2,30	3,29	14,90	18,10	
CFH-48	1.8898	48	49,2		1,6	49,8	1,5	2,30	3,45	15,30	17,60	
CFH-50	1.9685	50	51,2		1,6	51,8	1,5	2,30	3,57	15,80	17,20	
CFH-52	2.0472	52	53,5		1,6	54,3	1,5	2,30	3,58	20,65	16,30	
CFH-53	2.0866	53	54,5		1,6	55,3	1,5	2,30	3,82	21,05	16,10	
CFH-55	2.1654	55	56,5		1,6	57,3	1,5	2,30	3,93	21,80	15,70	
CFH-57	2.2441	57	58,5		1,6	59,3	1,5	2,30	4,12	22,60	15,30	
CFH-58	2.2835	58	59,5		1,6	60,3	1,5	2,30	4,13	23,00	15,00	
CFH-60	2.3622	60	61,5		1,6	62,3	1,5	2,30	4,28	23,80	14,60	
CFH-62	2.4409	62	63,5		+0,19	1,6	64,3	1,5	2,30	4,42	24,60	14,20
CFH-63	2.4803	63	64,5			1,6	65,3	1,5	2,30	4,50	25,00	13,70
CFH-65	2.5591	65	66,5			1,6	67,3	1,5	2,30	4,72	25,70	13,60
CFH-68	2.6772	68	69,5			1,6	70,3	1,5	2,30	4,90	26,90	12,90
CFH-70	2.7559	70	71,5	1,6		72,3	1,5	2,30	4,93	27,70	12,80	
CFH-72	2.8346	72	73,8	2,2		74,6	2,0	2,80	8,49	34,20	35,70	
CFH-73	2.8740	73	74,8	2,2		75,6	2,0	2,80	8,52	34,70	35,30	
CFH-74	2.9134	74	75,8	2,2		76,6	2,0	2,80	8,60	35,30	34,80	
CFH-76	2.9921	76	77,8	2,2		78,6	2,0	2,80	8,89	36,20	33,80	
CFH-78	3.0709	78	79,8	2,2		80,6	2,0	2,80	9,05	37,10	32,60	
CFH-79	3.1102	79	80,8	+0,22	2,2	81,6	2,0	2,80	9,07	37,60	32,00	
CFH-80	3.1496	80	81,8		2,2	82,6	2,0	2,80	9,22	38,00	31,40	
CFH-81	3.1890	81	82,8		2,2	83,6	2,0	2,80	9,31	38,60	31,30	
CFH-82	3.2283	82	83,8		2,2	84,6	2,0	2,80	9,45	39,00	30,70	
CFH-83	3.2677	83	84,8		2,2	85,6	2,0	2,80	9,63	39,50	30,10	
CFH-85	3.3465	85	86,8		2,2	87,6	2,0	2,80	9,81	40,40	29,60	
CFH-86	3.3858	86	87,8		2,2	88,6	2,0	2,80	9,91	40,90	29,00	
CFH-88	3.4646	88	90,0		2,7	91,0	2,5	3,40	15,40	46,50	65,80	
CFH-90	3.5433	90	92,0		2,7	93,0	2,5	3,40	15,60	47,60	63,50	
CFH-92	3.6220	92	94,0		2,7	95,0	2,5	3,40	16,60	48,60	62,00	
CFH-93	3.6614	93	95,0	2,7	96,0	2,5	3,40	16,80	49,20	61,80		
CFH-95	3.7402	95	97,0	2,7	98,0	2,5	3,40	16,90	50,20	59,30		
CFH-97	3.8189	97	99,0	2,7	100,0	2,5	3,40	17,10	51,30	58,20		

Hardness: Sizes 7-20, 47-52HRC; Sizes 21 & Over, 45-50 HRC

For alternate cutoff styles, contact Rotor Clip Technical Sales at +1.732.469.7333 (E-mail: tech@rotorclip.com)

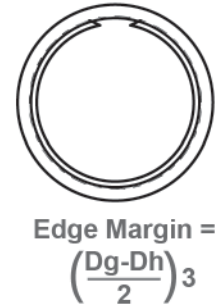
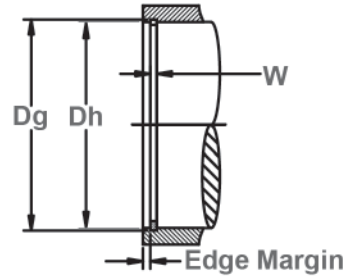
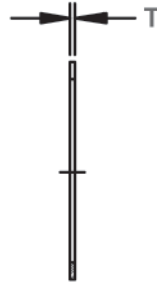
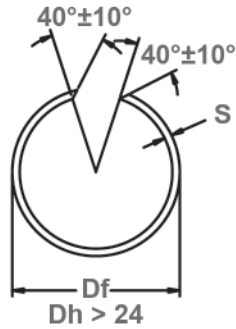
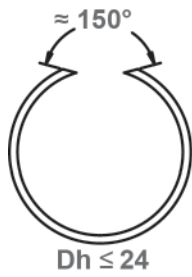

Free Diameter & Ring Dimensions

Housing Diameter & Groove Dimensions

RING SIZE	HOUSING DIAMETER		GROOVE DIMENSIONS				RING DIMENSIONS & WEIGHT				THRUST LOAD	
	Dh DEC	Dh mm	DIAMETER		WIDTH	FREE DIAMETER	THICKNESS	SECTION	WEIGHT	Pg (kN)	Pr (kN)	
			Dg	TOL.								
CFH-98	3.8583	98	100,0	+0,22	2,7	101,0	2,5	3,40	17,50	51,80	56,60	
CFH-100	3.9370	100	102,0		2,7	103,0	2,5	3,40	17,90	52,80	55,50	
CFH-102	4.0157	102	104,3		2,7	105,3	2,5	3,40	18,40	62,00	53,60	
CFH-103	4.0551	103	105,3		2,7	106,3	2,5	3,40	18,50	62,60	53,20	
CFH-105	4.1339	105	107,3		2,7	108,3	2,5	3,40	18,70	63,80	51,80	
CFH-107	4.2126	107	109,3		2,7	110,3	2,5	3,40	19,10	65,00	50,70	
CFH-108	4.2520	108	110,3		2,7	111,3	2,5	3,40	19,30	65,60	50,50	
CFH-110	4.3307	110	112,3		2,7	113,4	2,5	3,40	19,80	66,80	49,00	
CFH-112	4.4094	112	114,3		2,7	115,4	2,5	3,40	20,30	68,00	47,00	
CFH-113	4.4488	113	115,3		2,7	116,4	2,5	3,40	20,50	68,60	46,50	
CFH-115	4.5276	115	117,3		2,7	118,4	2,5	3,40	20,60	69,40	45,50	
CFH-117	4.6063	117	119,3		2,7	120,4	2,5	3,40	20,80	71,00	44,60	
CFH-118	4.6457	118	120,3		2,7	121,4	2,5	3,40	21,10	71,70	44,20	
CFH-120	4.7244	120	122,3		2,7	123,5	2,5	3,40	21,40	72,80	43,30	
CFH-123	4.8425	123	125,3		2,7	126,5	2,5	3,40	22,00	74,70	41,20	
CFH-125	4.9213	125	127,3		2,7	128,5	2,5	3,40	22,50	75,90	40,20	
CFH-127	5.0000	127	129,3		2,7	130,5	2,5	3,40	23,00	77,00	39,80	
CFH-130	5.1181	130	132,3		+0,25	2,7	133,6	2,5	3,40	23,40	78,90	38,20
CFH-133	5.2362	133	135,3			2,7	136,6	2,5	3,40	24,40	80,70	36,80
CFH-135	5.3150	135	137,3	2,7		138,6	2,5	3,40	25,00	81,90	36,60	
CFH-137	5.3937	137	139,3	2,7		140,6	2,5	3,40	25,30	83,00	35,60	
CFH-140	5.5118	140	142,6	2,7		144,0	2,5	4,00	29,30	96,10	40,20	
CFH-143	5.6299	143	145,6	2,7		147,0	2,5	4,00	30,10	98,10	38,60	
CFH-150	5.9055	150	152,6	2,7		154,1	2,5	4,00	31,90	102,00	36,20	
CFH-153	6.0236	153	155,6	2,7		157,1	2,5	4,00	32,60	104,00	35,60	
CFH-160	6.2992	160	162,6	2,7		164,2	2,5	4,00	34,40	108,00	34,60	
CFH-163	6.4173	163	165,6	2,7		167,2	2,5	4,00	34,60	111,00	33,50	
CFH-165	6.4961	165	167,6	2,7		169,2	2,5	4,00	34,90	113,00	32,80	
CFH-170	6.6929	170	172,6	2,7		174,3	2,5	4,00	36,20	116,00	32,00	
CFH-173	6.8110	173	175,6	2,7		177,3	2,5	4,00	37,10	118,00	32,00	
CFH-175	6.8898	175	177,6	2,7		179,3	2,5	4,00	37,30	119,00	31,40	
CFH-180	7.0866	180	182,6	2,7		184,5	2,5	4,00	38,30	123,00	30,80	
CFH-183	7.2047	183	185,6	+0,29		2,7	187,5	2,5	4,00	41,00	125,00	30,00
CFH-190	7.4803	190	193,0			3,2	194,9	3,0	5,00	61,30	150,00	62,80
CFH-195	7.6772	195	198,0			3,2	199,9	3,0	5,00	61,60	154,00	61,50

Hardness: Sizes 7-20, 47-52HRC; Sizes 21 & Over, 45-50 HRC



# CFH Constant Section

## Snap Ring, Internal, Metric Flat Wire.

Once installed in the groove of a housing/bore, the portion of the ring protruding from the groove holds an assembly in place.

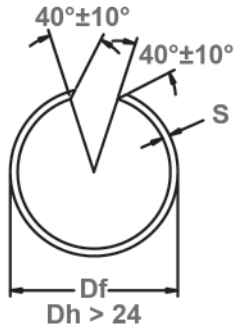
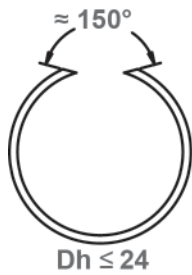

Free Diameter & Ring Dimensions

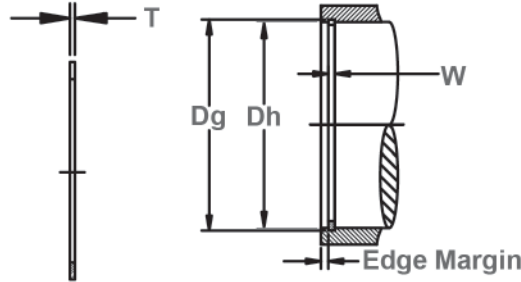

Housing Diameter & Groove Dimensions

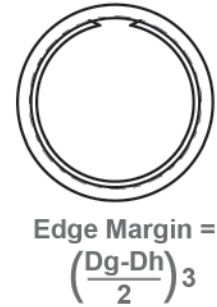

RING SIZE	HOUSING DIAMETER		GROOVE DIMENSIONS			RING DIMENSIONS & WEIGHT				THRUST LOAD	
	Dh DEC	Dh mm	DIAMETER		WIDTH W min	FREE DIAMETER Df min	THICKNESS T -0,1	SECTION S -0,1	WEIGHT kg/1000	Pg (kN)	Pr (kN)
			Dg	TOL.							
CFH-200	7.8740	200	203,0	+0,29	3,2	205,0	3,0	5,00	64,50	158,00	59,00
CFH-205	8.0709	205	208,0		3,2	210,0	3,0	5,00	66,40	162,00	57,80
CFH-210	8.2677	210	213,0		3,2	215,1	3,0	5,00	68,80	166,00	56,80
CFH-215	8.4646	215	218,0		3,2	220,1	3,0	5,00	69,50	169,00	55,50
CFH-220	8.6614	220	223,0		3,2	225,2	3,0	5,00	72,40	173,00	54,40
CFH-225	8.8583	225	228,0		3,2	230,2	3,0	5,00	72,90	177,00	53,30
CFH-230	9.0551	230	233,0		3,2	235,3	3,0	5,00	75,20	181,00	52,00
CFH-240	9.4488	240	243,0		3,2	245,4	3,0	5,00	80,90	189,00	49,60
CFH-250	9.8425	250	253,0		3,2	255,5	3,0	5,00	84,20	197,00	48,50
CFH-260	10.2362	260	265,0		4,2	267,6	4,0	7,50	165,00	343,00	162,00
CFH-270	10.6299	270	275,0	4,2	277,7	4,0	7,50	174,00	356,00	157,00	
CFH-280	11.0236	280	285,0	4,2	287,8	4,0	7,50	184,00	369,00	152,00	
CFH-290	11.4173	290	295,0	4,2	297,9	4,0	7,50	190,00	382,00	144,00	
CFH-300	11.8110	300	305,0	4,2	307,9	4,0	7,50	196,00	395,00	140,00	
CFH-310	12.2047	310	315,0	4,2	318,0	4,0	7,50	200,00	408,00	136,00	
CFH-320	12.5984	320	325,0	4,2	328,1	4,0	7,50	203,00	422,00	132,00	
CFH-325	12.7953	325	330,0	4,2	333,1	4,0	7,50	206,00	428,00	129,00	
CFH-330	12.9921	330	335,0	4,2	338,2	4,0	7,50	209,00	435,00	126,00	
CFH-340	13.3858	340	345,0	4,2	348,3	4,0	7,50	219,00	448,00	123,00	
CFH-350	13.7795	350	355,0	4,2	358,4	4,0	7,50	229,00	452,00	121,00	
CFH-355	13.9764	355	360,0	4,2	363,4	4,0	7,50	231,00	467,00	121,00	
CFH-360	14.1732	360	365,0	4,2	368,5	4,0	7,50	233,00	487,00	119,00	
CFH-370	14.5669	370	375,0	4,2	378,5	4,0	7,50	236,00	493,00	116,00	
CFH-375	14.7638	375	380,0	4,2	383,5	4,0	7,50	240,00	500,00	112,00	
CFH-380	14.9606	380	385,0	4,2	388,6	4,0	7,50	242,00	513,00	111,00	
CFH-390	15.3543	390	395,0	4,2	398,7	4,0	7,50	253,00	520,00	110,00	
CFH-395	15.5512	395	400,0	4,2	403,7	4,0	7,50	257,00	526,00	109,00	
CFH-400	15.7480	400	405,0	4,2	408,9	4,0	7,50	260,00	529,00	106,00	
CFH-410	16.1417	410	415,0	4,2	419,0	4,0	7,50	266,00	546,00	105,00	
CFH-420	16.3386	415	420,0	4,2	424,0	4,0	7,50	273,00	552,00	104,00	
CFH-420	16.5354	420	425,0	4,2	429,1	4,0	7,50	277,00	553,00	101,00	
CFH-430	16.9291	430	435,0	4,2	439,2	4,0	7,50	285,00	565,00	100,00	
CFH-440	17.3228	440	445,0	4,2	449,3	4,0	7,50	294,00	578,00	98,00	

Hardness: Sizes 7-20, 47-52HRC; Sizes 21 & Over, 45-50 HRC

For alternate cutoff styles, contact Rotor Clip Technical Sales at +1.732.469.7333 (E-mail: tech@rotorclip.com)



# Snap Ring, External, Metric

## For Bearings.

Once installed in the groove of a shaft, the portion of the ring protruding from the groove holds an assembly in place.

# CBS Constant Section

## DIN 5417



Free Diameter & Ring Dimensions  
With Section B-B

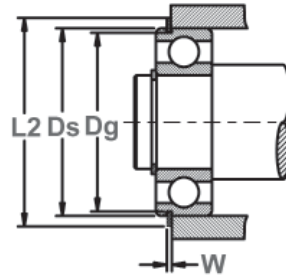
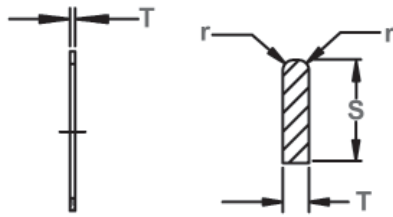

Shaft Diameter &  
Groove Dimensions

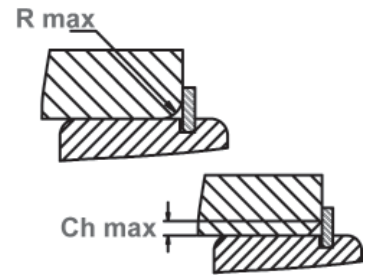

Maximum Corner  
Radius & Chamfer

RING SIZE	SHAFT DIAMETER		GROOVE DIMENSIONS				RING DIMENSIONS & WEIGHT								SUPPLEMENTARY DATA						
	Ds DEC	Ds mm	DIAMETER		WIDTH		THICKNESS		SECTION		FREE DIAMETER		GAP	RADIUS	WEIGHT	L2	Pg	Pr	R max Ch max	P'r kN	R.P.M. X1000 (1/min)
			Dg	TOL.	W	TOL.	T	TOL.	S	TOL.	Df	TOL.									
CBS-30	1.1811	30	28,17		1,35		1,12		3,25		27,4		3	0,4	2,8	34,7	13,7	16,6	2,0	2,91	16,0
CBS-32	1.2598	32	30,15		1,35		1,12		3,25		29,4		3	0,4	3,0	36,7	14,6	14,6	2,0	2,57	13,0
CBS-35	1.3780	35	33,17		1,35		1,12		3,25		32,4	+0,4	3	0,4	3,2	39,7	16,0	13,4	2,0	2,42	11,0
CBS-37	1.4567	37	34,77		1,35		1,12		3,25		34,0		3	0,4	3,4	41,3	20,7	13,6	2,0	2,45	10,0
CBS-40	1.5748	40	38,10		1,35		1,12		3,25		37,3		3	0,4	3,6	44,6	19,3	13,5	2,0	2,50	8,0
CBS-42	1.6535	42	39,75	-0,25	1,35		1,12		3,25		38,9		3	0,4	3,8	46,3	23,5	12,9	2,0	2,39	7,0
CBS-44	1.7323	44	41,75		1,35		1,12		3,25		40,9		3	0,4	4,0	48,3	24,6	12,4	2,0	2,29	7,0
CBS-47	1.8504	47	44,60		1,35		1,12		4,04		43,7	+0,5	4	0,4	5,3	52,7	28,8	12,1	2,0	2,29	7,0
CBS-50	1.9685	50	47,60		1,35		1,12		4,04		46,7		4	0,4	5,8	55,7	30,6	13,3	2,0	2,60	6,0
CBS-52	2.0472	52	49,73		1,35		1,12		4,04		48,8		4	0,4	5,9	57,9	31,6	12,8	2,5	2,01	6,0
CBS-55	2.1654	55	52,60		1,35		1,12		4,04		51,7		4	0,4	6,2	60,7	33,8	11,8	2,5	1,90	5,0
CBS-56	2.2047	56	53,60		1,35		1,12		4,04		52,4		4	0,4	6,5	61,7	34,5	12,1	2,5	1,95	5,0
CBS-58	2.2835	58	55,60		1,35	+0,3	1,12	-0,1	4,04	-0,15	54,4		4	0,4	6,7	63,7	35,6	11,5	2,5	1,89	5,0
CBS-62	2.4409	62	59,61		1,90		1,70		4,04		58,2		4	0,6	10,5	67,7	38,1	37,6	2,5	6,18	5,0
CBS-65	2.5591	65	62,60		1,90		1,70		4,04		61,2		4	0,6	11,0	70,7	40,0	34,9	2,5	5,89	4,0
CBS-68	2.6772	68	64,82		1,90		1,70		4,85		63,4		5	0,6	12,6	74,6	55,5	40,9	2,5	7,06	4,0
CBS-72	2.8346	72	68,81		1,90		1,70		4,85		67,4	+0,8	5	0,6	14,7	78,6	59,0	38,9	2,5	6,71	4,0
CBS-75	2.9528	75	71,83		1,90		1,70		4,85		70,4		5	0,6	15,3	81,6	61,5	36,6	2,5	6,46	3,0
CBS-80	3.1496	80	76,81		1,90		1,70		4,85		75,4		5	0,6	16,3	86,6	65,7	34,8	3,0	5,25	3,0
CBS-85	3.3465	85	81,81	-0,50	1,90		1,70		4,85		80,4		5	0,6	17,5	91,6	70,0	33,5	3,0	5,16	3,0
CBS-90	3.5433	90	86,79		2,70		2,46		4,85		85,4		5	0,7	26,6	96,5	74,0	93,9	3,0	14,80	2,0
CBS-95	3.7402	95	91,82		2,70		2,46		4,85		90,4		5	0,7	28,2	101,6	76,3	86,8	3,5	12,00	2,0
CBS-100	3.9370	100	96,80		2,70		2,46		4,85		95,2		5	0,7	29,2	106,5	82,5	80,8	3,5	11,40	2,0
CBS-110	4.3307	110	106,81		2,70		2,46		4,85		105,2	+1,0	5	0,7	32,8	116,6	90,7	71,2	3,5	10,40	1,0
CBS-115	4.5276	115	111,81		2,70		2,46		4,85		110,2		5	0,7	34,4	121,6	97,7	66,6	3,5	10,00	1,0
CBS-120	4.7244	120	115,21		3,10		2,82		7,21		113,6		7	0,7	60,6	129,7	143,0	140,0	3,5	21,30	2,0
CBS-125	4.9213	125	120,22		3,10		2,82		7,21		118,6		7	0,7	63,0	134,7	155,0	132,0	4,0	17,90	2,0





# CBS Constant Section

## DIN 5417

### Snap Ring, External, Metric

For Bearings.

Once installed in the groove of a shaft, the portion of the ring protruding from the groove holds an assembly in place.



Free Diameter & Ring Dimensions  
With Section B-B

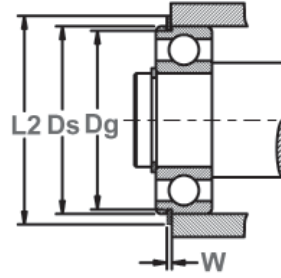
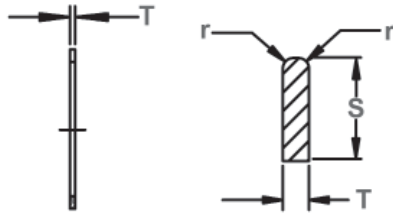

Shaft Diameter &  
Groove Dimensions

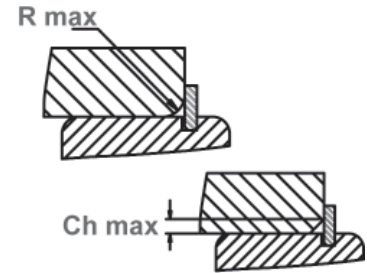

Maximum Corner  
Radius & Chamfer

RING SIZE	SHAFT DIAMETER		GROOVE DIMENSIONS				RING DIMENSIONS & WEIGHT							SUPPLEMENTARY DATA							
			DIAMETER		WIDTH		THICKNESS		SECTION		FREE DIAMETER		GAP	RADIUS		L2	Pg	Pr	R max Ch max	Pr kN	R.P.M. X1000 (1/min)
	Ds DEC	Ds mm	Dg	TOL.	W	TOL.	T	TOL.	S	TOL.	Df	TOL.		g	r min.						
CBS-130	5.1181	130	125,22		3,10		2,82		7,21		123,6	+1,0	7	0,7	65,6	139,7	166,0	124,7	4,0	17,30	1,0
CBS-140	5.5118	140	135,23		3,10		2,82		7,21		133,0		7	0,7	70,6	149,7	180,0	111,6	4,0	16,00	1,0
CBS-145	5.7087	145	140,23		3,10		2,82		7,21		138,0		7	0,7	73,0	154,7	186,0	106,4	4,0	15,50	1,0
CBS-150	5.9055	150	145,24		3,10		2,82		7,21		142,9	+1,6	7	0,7	77,2	159,7	193,0	101,5	4,0	15,00	1,0
CBS-160	6.2992	160	155,22		3,10	+0,3	2,82		7,21		152,9		7	0,7	81,0	169,7	206,0	92,0	4,0	14,10	1,0
CBS-170	6.6929	170	163,65		3,50		3,10		9,60		161,3		10	0,7	122,0	182,9	283,0	148,0	5,0	18,70	1,0
CBS-180	7.0866	180	173,66		3,50		3,10		9,60	-0,15	171,2		10	0,7	128,0	192,9	292,0	135,0	5,0	17,70	1,0
CBS-190	7.4803	190	183,64		3,50		3,10		9,60		181,0		10	0,7	139,0	202,9	311,0	124,0	5,0	16,70	1,0
CBS-200	7.8740	200	193,65		3,50		3,10	-0,1	9,60		191,0		10	0,7	148,0	212,9	336,0	116,0	5,0	16,00	1,0
CBS-210	8.2677	210	203,60		3,50		3,10		9,60		200,9		10	1,2	156,0	222,8	356,0	106,0	6,0	12,70	1,0
CBS-215	8.4646	215	208,60		3,50		3,10		9,60		205,9	+1,8	10	1,2	160,0	227,8	376,0	103,0	6,0	12,40	1,0
CBS-225	8.8583	225	217,00	-0,50	4,50		3,50		10,00		214,3		10	1,2	196,0	237,0	462,0	144,0	6,0	17,90	1,0
CBS-230	9.0551	230	222,00		4,50		3,50		10,00		219,2		10	1,2	200,0	242,0	473,0	139,1	6,0	17,50	1,0
CBS-240	9.4488	240	232,00		4,50		3,50		10,00		229,2		10	1,2	209,0	252,0	495,0	130,0	6,0	16,80	0,5
CBS-250	9.8425	250	242,00		4,50	+0,4	3,50		10,00		239,2		10	1,2	220,0	262,0	514,0	122,0	6,0	16,10	0,5
CBS-260	10.2362	260	252,00		4,50		3,50		10,00		247,5		10	1,2	230,0	272,0	536,0	114,0	6,0	15,50	0,5
CBS-270	10.6299	270	262,00		4,50		3,50		10,00		257,5		10	1,2	240,0	282,0	556,0	107,0	6,0	14,90	0,5
CBS-280	11.0236	280	272,00		4,50		3,50		10,00		267,5	+2,5	10	1,2	250,0	292,0	578,0	101,0	6,0	14,40	0,5
CBS-290	11.4173	290	282,00		4,50		3,50		10,00		277,5		10	1,2	260,0	302,0	598,0	95,4	6,0	13,90	0,4
CBS-300	11.8110	300	290,00		5,50		4,50		12,00		284,5		10	1,5	400,0	314,0	694,0	230,0	7,0	34,20	0,6
CBS-310	12.2047	310	300,00		5,50		4,50		12,00	-0,30	294,0		10	1,5	412,0	324,0	800,0	218,0	7,0	28,40	0,5
CBS-320	12.5984	320	310,00		5,50		4,50		12,00		304,0		10	1,5	420,0	334,0	824,0	207,0	7,0	27,60	0,5
CBS-340	13.3858	340	330,00		5,50	+0,5	4,50	-0,2	12,00		324,0		10	1,5	446,0	354,0	875,0	187,0	7,0	26,00	0,4
CBS-360	14.1732	360	350,00		5,50		4,50		12,00		343,0	+3,0	10	1,5	475,0	374,0	930,0	169,0	7,0	24,50	0,4
CBS-370	14.5669	370	360,00		5,50		4,50		12,00		353,0		10	1,5	485,0	384,0	955,0	162,0	7,0	23,80	0,4
CBS-380	14.9606	380	370,00		5,50		4,50		12,00		363,0		10	1,5	500,0	394,0	995,0	154,0	7,0	23,20	0,4
CBS-400	15.7480	400	390,00		5,50		4,50		12,00		383,0		10	1,5	525,0	414,0	1040,0	144,0	7,0	22,10	0,3

# Snap Ring, External, Metric

## Round Wire.

Once installed in the groove of a shaft, the portion of the ring protruding from the groove holds an assembly in place.

# CRS Constant Section DIN 7993 Type A

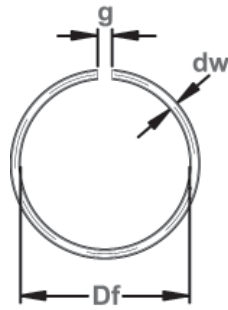

Free Diameter & Ring Dimensions

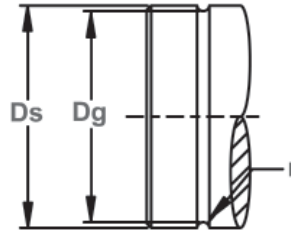

Shaft Diameter & Groove Dimensions

RING SIZE	SHAFT DIAMETER		GROOVE DIMENSIONS			RING DIMENSIONS & WEIGHT					R.P.M. X1000 (1/min)
			DIAMETER		RADIUS	WIRE DIA.	FREE DIAMETER		GAP	WEIGHT	
	Ds DEC	Ds mm	Dg	TOL.	r		dw	Df			
CRS-4	0.1575	4	3,2	±0,05	0,5	0,8	3,1	-0,2	1	0,044	175
CRS-5	0.1969	5	4,2		0,5	0,8	4,1		1	0,057	112
CRS-6	0.2362	6	5,2		0,5	0,8	5,1		1	0,069	77
CRS-7	0.2756	7	6,2		0,5	0,8	6,1	2	0,077	57	
CRS-8	0.3150	8	7,2		0,5	0,8	7,1	2	0,090	44	
CRS-10	0.3937	10	9,2		0,5	0,8	9,1	2	0,115	28	
CRS-12	0.4724	12	11,0		0,6	1,0	10,8	3	0,210	24	
CRS-14	0.5512	14	13,0		0,6	1,0	12,8	3	0,250	18	
CRS-16	0.6299	16	14,4		0,9	1,6	14,2	3	0,740	22	
CRS-18	0.7087	18	16,4		0,9	1,6	16,2	3	0,830	17	
CRS-20	0.7874	20	18,0	±0,10	1,1	2,0	17,7	-0,5	3	1,450	18
CRS-22	0.8661	22	20,0		1,1	2,0	19,7		3	1,600	15
CRS-24	0.9449	24	22,0		1,1	2,0	21,7		3	1,780	12
CRS-25	0.9843	25	23,0		1,1	2,0	22,7	3	1,840	11	
CRS-26	1.0236	26	24,0		1,1	2,0	23,7	3	1,910	10	
CRS-28	1.1024	28	26,0		1,1	2,0	25,7	3	2,070	9	
CRS-30	1.1811	30	28,0		1,1	2,0	27,7	3	2,220	8	
CRS-32	1.2598	32	29,5		1,4	2,5	29,1	4	3,670	9	
CRS-35	1.3780	35	32,5		1,4	2,5	32,1	4	3,980	7	
CRS-38	1.4961	38	35,5		1,4	2,5	35,1	4	4,400	6	
CRS-40	1.5748	40	37,5	1,4	2,5	37,1	4	4,640	6		
CRS-42	1.6535	42	39,5	1,4	2,5	39,0	4	4,870	5		
CRS-45	1.7717	45	42,5	1,4	2,5	42,0	4	5,230	4		
CRS-48	1.8898	48	45,5	1,4	2,5	45,0	4	5,600	4		
CRS-50	1.9685	50	47,5	1,4	2,5	47,0	4	5,830	4		
CRS-55	2.1654	55	51,8	±0,15	1,8	3,2	51,1	-0,8	4	10,510	4
CRS-60	2.3622	60	56,8		1,8	3,2	56,1		4	11,500	3
CRS-65	2.5591	65	61,8		1,8	3,2	61,1		4	12,490	3
CRS-70	2.7559	70	66,8		1,8	3,2	66,0	5	13,400	2	
CRS-75	2.9528	75	71,8		1,8	3,2	71,0	5	14,390	2	
CRS-80	3.1496	80	76,8		1,8	3,2	76,0	5	15,380	2	
CRS-85	3.3465	85	81,8		1,8	3,2	81,0	5	16,380	2	
CRS-90	3.5433	90	86,8		1,8	3,2	86,0	5	17,370	1	
CRS-95	3.7402	95	91,8		1,8	3,2	91,0	5	18,360	1	
CRS-100	3.9370	100	96,8		1,8	3,2	95,8	5	19,310	1	
CRS-105	4.1339	105	101,8	±0,15	1,8	3,2	100,8	-1,0	5	20,300	1
CRS-110	4.3307	110	106,8		1,8	3,2	105,8		5	21,290	1
CRS-115	4.5276	115	111,8		1,8	3,2	110,8		5	22,290	1
CRS-120	4.7244	120	116,8		1,8	3,2	115,8		5	23,280	1
CRS-125	4.9213	125	121,8		1,8	3,2	120,8		5	24,270	1

For alternate cutoff styles, contact Rotor Clip Technical Sales at +1.732.469.7333 (E-mail: tech@rotorclip.com)



# Snap Ring, Internal, Metric

## Round Wire.

Once installed in the groove of a housing/bore, the portion of the ring protruding from the groove holds an assembly in place.

# CRH Constant Section

## DIN 7993 Type B

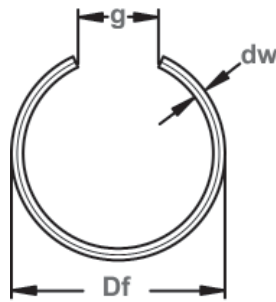

Free Diameter & Ring Dimensions

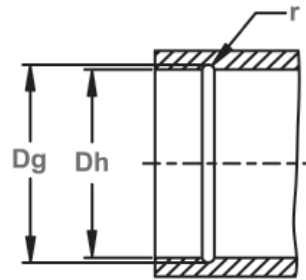

Housing Diameter & Groove Dimensions

RING SIZE	HOUSING DIAMETER		GROOVE DIMENSIONS			RING DIMENSIONS & WEIGHT				
	Dh DEC	Dh mm	DIAMETER		RADIUS	WIRE DIA.	FREE DIAMETER		GAP (g)	WEIGHT kg/1000
			Dg	TOL.	r		Df	TOL.		
CRH-7	0.2756	7	7,80	±0,05	0,5	0,8	7,9	+0,3	4	0,071
CRH-8	0.3150	8	8,80		0,5	0,8	8,9		4	0,083
CRH-10	0.3937	10	10,80		0,5	0,8	10,9		4	0,108
CRH-12	0.4724	12	13,00	±0,05	0,6	1,0	13,2	+0,4	6	0,196
CRH-14	0.5512	14	15,00		0,6	1,0	15,2		6	0,234
CRH-16	0.6299	16	17,60		0,9	1,6	17,8		8	0,706
CRH-18	0.7087	18	19,60	±0,10	0,9	1,6	19,8	+0,5	8	0,804
CRH-20	0.7874	20	22,00		1,1	2,0	22,3		10	1,320
CRH-22	0.8661	22	24,00		1,1	2,0	24,3		10	1,470
CRH-24	0.9449	24	26,00	±0,10	1,1	2,0	26,3	+0,5	10	1,630
CRH-25	0.9843	25	27,00		1,1	2,0	27,3		10	1,700
CRH-26	1.0236	26	28,00		1,1	2,0	28,3		10	1,790
CRH-28	1.1024	28	30,00	±0,10	1,1	2,0	30,3	+0,6	10	1,940
CRH-30	1.1811	30	32,00		1,1	2,0	32,3		10	2,100
CRH-32	1.2598	32	34,50		1,4	2,5	34,9		12	3,470
CRH-35	1.3780	35	37,50	±0,15	1,4	2,5	37,9	+0,8	12	3,850
CRH-38	1.4961	38	40,50		1,4	2,5	40,9		12	4,200
CRH-40	1.5748	40	42,50		1,4	2,5	42,9		12	4,430
CRH-42	1.6535	42	44,50	±0,15	1,4	2,5	45,0	+1,0	16	4,540
CRH-45	1.7717	45	47,50		1,4	2,5	48,8		16	4,890
CRH-48	1.8898	48	50,50		1,4	2,5	51,0		16	5,240
CRH-50	1.9685	50	52,50	±0,15	1,4	2,5	53,0	+1,0	16	5,510
CRH-55	2.1654	55	58,20		1,8	3,2	58,9		20	9,770
CRH-60	2.3622	60	63,20		1,8	3,2	63,9		20	10,760
CRH-65	2.5591	65	68,20	±0,15	1,8	3,2	68,9	+1,0	20	11,750
CRH-70	2.7559	70	73,20		1,8	3,2	74,0		25	12,440
CRH-75	2.9528	75	78,20		1,8	3,2	79,0		25	13,430
CRH-80	3.1496	80	83,20	±0,15	1,8	3,2	84,0	+1,2	25	14,420
CRH-85	3.3465	85	88,20		1,8	3,2	89,0		25	15,410
CRH-90	3.5433	90	93,20		1,8	3,2	94,0		25	16,400
CRH-95	3.7402	95	98,20	±0,15	1,8	3,2	99,0	+1,2	25	17,390
CRH-100	3.9370	100	103,20		1,8	3,2	104,2		32	17,980
CRH-105	4.1339	105	108,20		1,8	3,2	109,2		32	18,980
CRH-110	4.3307	110	113,20	±0,15	1,8	3,2	114,2	+1,2	32	19,970
CRH-115	4.5276	115	118,20		1,8	3,2	119,2		32	20,960
CRH-120	4.7244	120	123,20		1,8	3,2	124,2		32	21,950
CRH-125	4.9213	125	128,20	±0,15	1,8	3,2	129,2	32	22,940	

For alternate cutoff styles, contact Rotor Clip Technical Sales at +1.732.469.7333 (E-mail: tech@rotorclip.com)

# Constant Section Ring Optional **Cutoff Styles**®

The following cutoff styles represent “specials” requested by the marketplace over a period of many years. One of these configurations may suit your application requirements and may be substituted for any size ring listed in the catalog specification pages. Or, we can make any configuration your application requires. For more information, contact Rotor Clip technical sales: +1 732-469-7333, E-mail: tech@rotorclip.com.

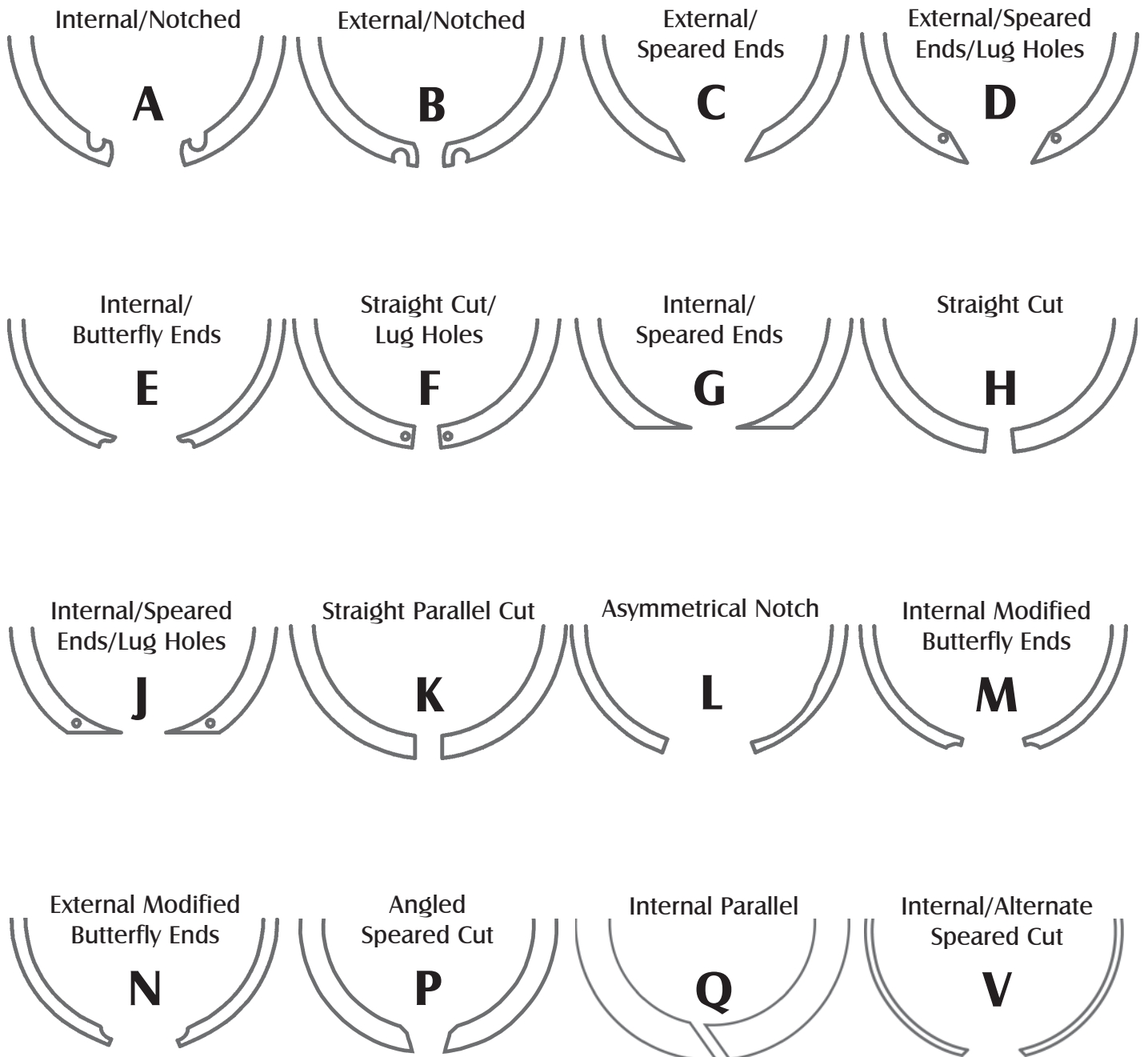

# C KL Spiral Housing Rings

**Internal, Light Duty**  
These single-turn snap rings are ideal for light duty applications.

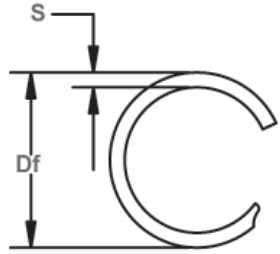

Free Diameter & Ring Measurements

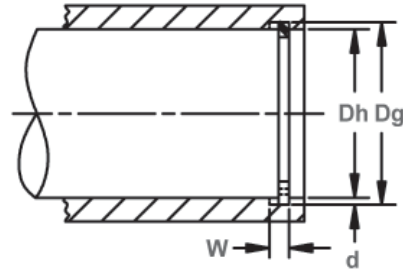
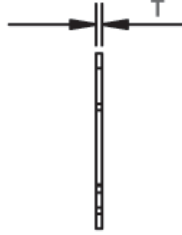

Housing Diameter & Groove Dimensions

RING NO.	HOUSING DIAMETER		GROOVE SIZE				FREE DIAMETER			RING SIZE THICKNESS		SECTION		THRUST LOAD (lbs.)	
			DIAMETER		WIDTH		DEPTH	DIAMETER		THICKNESS		SECTION		RING Safety factor of 3	GROOVE Safety factor of 2
	Dh	Dg	Tol.	W	Tol.	d	Df	Tol.	T	Tol.	S	Tol.			
KL-25*	.250	.262		.015		.006	.264		.012		.020		481	106	
KL-31*	.312	.326		.018		.007	.329	+ .010	.015		.025		750	154	
KL-37*	.375	.395		.018		.010	.398	- .000	.015		.030		901	265	
KL-43	.437	.463	+ .002	.018		.013	.466	+ .012/- .000	.015		.030		1050	402	
KL-50	.500	.528	- .002	.022		.014	.531		.018		.045		1300	500	
KL-56	.562	.590		.022		.014	.593		.018		.045		1460	560	
KL-62	.625	.653		.022		.014	.656		.018		.045		1630	620	
KL-68	.687	.715		.022		.014	.719		.018		.045		1790	680	
KL-75	.750	.779		.022		.015	.783	+ .013	.018		.045		1950	800	
KL-81	.812	.854		.026	+ .002	.021	.862	- .000	.021	+ .0015	.065		2460	1210	
KL-87	.875	.917	+ .003	.026	- .000	.021	.926		.021	- .0015	.065		2660	1300	
KL-93	.937	.979	- .003	.026		.021	.989		.021		.065		2840	1390	
KL-100	1.000	1.042		.026		.021	1.052		.021		.065		3040	1480	
KL-106	1.062	1.106		.031		.022	1.117		.025		.088		3500	1650	
KL-112	1.125	1.169		.031		.022	1.180		.025		.088		3710	1750	
KL-118	1.187	1.231		.031		.022	1.242		.025		.088		3920	1850	
KL-125	1.250	1.294	+ .004	.031		.022	1.307	+ .015	.025	- .000	.088		4120	1940	
KL-131	1.312	1.356	- .004	.031		.022	1.369		.025		.088		4330	2040	
KL-137	1.375	1.419		.031		.022	1.433		.025		.088		4540	2140	
KL-143	1.437	1.481		.031		.022	1.496		.025		.088		4740	2240	
KL-150	1.500	1.544		.031		.022	1.559		.025		.088		4950	2330	
KL-156	1.562	1.619		.039		.029	1.637		.031		.118	+ .004	6390	3200	
KL-162	1.625	1.682		.039		.029	1.701		.031		.118	- .004	6650	3330	
KL-168	1.687	1.744		.039		.029	1.763		.031		.118		6900	3460	
KL-175	1.750	1.807	+ .005	.039		.029	1.827	+ .020	.031	- .000	.118		7160	3590	
KL-181	1.812	1.869	- .005	.039		.029	1.890		.031		.118		7410	3710	
KL-187	1.875	1.932		.039		.029	1.953		.031		.118		7670	3840	
KL-193	1.937	1.994		.039		.029	2.016		.031		.118		7920	3970	
KL-200	2.000	2.057		.039		.029	2.079		.031		.118		8180	4100	
KL-206	2.062	2.138		.039		.038	2.162		.031		.158		8430	5540	
KL-212	2.125	2.201		.039	+ .003	.038	2.226		.031	+ .002	.158		8690	5710	
KL-218	2.187	2.263		.039	- .000	.038	2.289		.031	- .002	.158		8950	5870	
KL-225	2.250	2.326		.039		.038	2.352		.031		.158		9200	6040	
KL-231	2.312	2.388		.039		.038	2.415		.031		.158		9460	6210	
KL-237	2.375	2.451		.039		.038	2.478		.031		.158		9720	6380	
KL-243	2.437	2.513	+ .006	.039		.038	2.541	+ .025	.031	- .000	.158		9970	6550	
KL-250	2.500	2.576	- .006	.039		.038	2.605		.031		.158		10230	6720	
KL-256	2.562	2.638		.039		.038	2.667		.031		.158		10480	6880	
KL-262	2.625	2.701		.039		.038	2.731		.031		.158		10740	7050	
KL-268	2.687	2.763		.039		.038	2.794		.031		.158		10990	7220	
KL-275	2.750	2.826		.039		.038	2.857		.031		.158		11250	7390	
KL-281	2.812	2.888		.039		.038	2.920		.031		.158		11500	7550	
KL-287	2.875	2.951		.039		.038	2.983		.031		.158		11760	7720	
KL-293	2.937	3.013		.039		.038	3.046		.031		.158		12010	7890	
KL-300	3.000	3.076		.039		.038	3.110		.031		.158		12270	8060	

\* No Removal Notch.



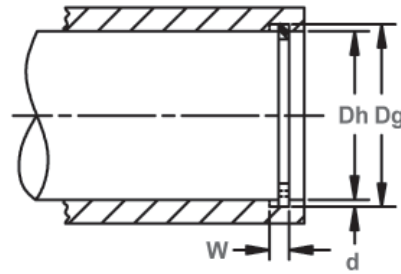
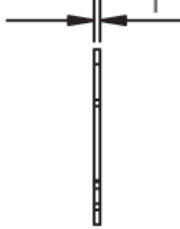
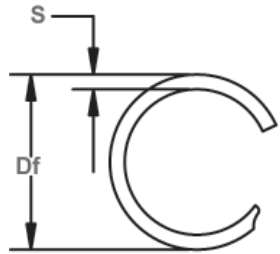

Free Diameter & Ring Measurements

Housing Diameter & Groove Dimensions

RING NO.	HOUSING DIAMETER (In.)	GROOVE SIZE					RING SIZE					THRUST LOAD (lbs.)		
		DIAMETER		WIDTH		DEPTH	FREE DIAMETER		THICKNESS		SECTION		RING Safety factor of 3	GROOVE Safety factor of 2
		Dh	Dg	Tol.	W	Tol.	d	Df	Tol.	T	Tol.	S	Tol.	
KL-306	3.062	3.154		.044		.046	3.188		.039		.188		15760	9960
KL-312	3.125	3.217		.044		.046	3.251		.039		.188		16080	10160
KL-318	3.187	3.279		.044		.046	3.314		.039		.188		16400	10360
KL-325	3.250	3.342		.044		.046	3.377		.039		.188		16720	10570
KL-331	3.312	3.404		.044		.046	3.440		.039		.188		17040	10770
KL-337	3.375	3.467		.044		.046	3.504		.039		.188		17370	10970
KL-343	3.437	3.529		.044		.046	3.566		.039		.188		17690	11180
KL-350	3.500	3.592		.044		.046	3.630		.039		.188		18010	11380
KL-356	3.562	3.654		.044		.046	3.692		.039		.188		18330	11580
KL-362	3.625	3.717	+ .006	.044	- .000	.046	3.756	+ .030	.039	- .000	.188		18650	11790
KL-368	3.687	3.779	- .006	.044		.046	3.819		.039		.188		18970	11990
KL-375	3.750	3.842		.044		.046	3.882		.039		.188		19300	12190
KL-381	3.812	3.904		.044		.046	3.945		.039		.188		19620	12400
KL-387	3.875	3.967		.044		.046	4.009		.039		.188		19940	12600
KL-393	3.937	4.029		.044		.046	4.071		.039		.188		20260	12800
KL-400	4.000	4.092		.044		.046	4.135		.039		.188		20580	13010
KL-412	4.125	4.235		.052		.055	4.279		.046		.225	+ .005	23850	16040
KL-425	4.250	4.360		.052		.055	4.405		.046		.225	- .005	24570	16520
KL-437	4.375	4.485		.052		.055	4.531		.046		.225		25290	17010
KL-450	4.500	4.610		.052		.055	4.658	+ .035	.046		.225		26010	17500
KL-462	4.625	4.735		.052		.055	4.784	- .000	.046		.225		26740	17980
KL-475	4.750	4.860		.052		.055	4.910		.046	+ .002	.225		27460	18470
KL-487	4.875	4.985		.052		.055	5.036		.046	- .002	.225		28180	18950
KL-500	5.000	5.110		.052		.055	5.163		.046		.225		28900	19440
KL-525	5.250	5.381		.067		.066	5.435		.061		.225		40240	24490
KL-550	5.500	5.638	+ .007	.067	+ .004	.069	5.694		.061		.225		42160	26830
KL-575	5.750	5.894	- .007	.067	- .000	.072	5.953		.061		.225		44080	29260
KL-600	6.000	6.150		.067		.075	6.212	+ .045	.061		.265		45990	31810
KL-625	6.250	6.406		.067		.078	6.470	- .000	.061		.265		47910	34460
KL-650	6.500	6.663		.067		.082	6.730		.061		.265		49830	37680
KL-675	6.750	6.919		.067		.085	6.988		.061		.265		51740	40560
KL-700	7.000	7.175		.067		.088	7.247		.061		.265		53660	43540
KL-725	7.250	7.431		.067		.091	7.505		.061		.265		55580	46640
KL-750	7.500	7.688		.067		.094	7.765		.061		.265		57490	49830
KL-775	7.750	7.944		.067		.097	8.023	+ .060	.061		.300		59410	53140
KL-800	8.000	8.200	+ .008	.067	- .008	.100	8.282	- .000	.061		.300		61320	56500
KL-825	8.250	8.456		.067		.103	8.541		.061		.300		63240	60000
KL-850	8.500	8.713		.067		.107	8.800		.061		.300		65160	64290
KL-875	8.750	8.969		.082		.110	9.059		.076		.345	+ .004	83570	68040
KL-900	9.000	9.225		.082		.113	9.317		.076		.345	- .008	85950	71890
KL-925	9.250	9.481		.082	+ .005	.116	9.576	+ .070	.076		.345		88340	75850
KL-950	9.500	9.738		.082	- .000	.119	9.835	- .000	.076		.345		90730	79910
KL-975	9.750	9.994		.082		.122	10.094		.076		.345		93120	84080
KL-1000	10.000	10.250		.082		.125	10.353		.076		.345		95500	88360

# CL Spiral Shaft Rings

**External, Light Duty**  
 These single-turn snap rings are ideal for light duty applications.

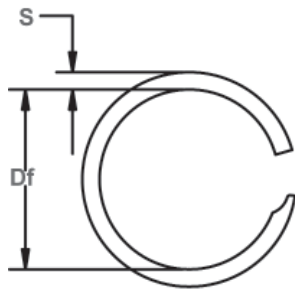

Free Diameter & Ring Measurements

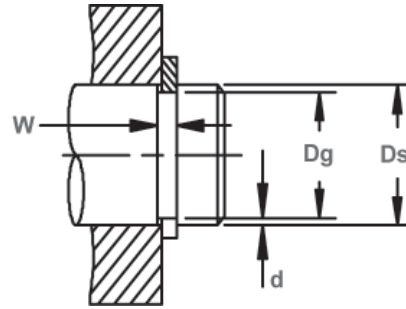

Shaft Diameter & Groove Dimensions

RING NO.	SHAFT DIAMETER (In.)	GROOVE SIZE					RING SIZE				SECTION		THURST LOAD (lbs.)		R.P.M. LIMITS Standard Material (Carbon Steel)
		DIAMETER		WIDTH		DEPTH	FREE DIAMETER			THICKNESS		RING Safety factor of 3	GROOVE Safety factor of 2		
		Dg	Tol.	W	Tol.	d	Df	Tol.	T	Tol.	S			Tol.	
CL-25*	.250	.238		.015		.006	.236		.012		.020		481	106	45227
CL-31*	.312	.297		.018		.008	.294	+.000	.015		.025		750	165	39946
CL-37*	.375	.351		.018		.012	.348	-.010	.015		.025		901	318	31161
CL-43	.437	.413	+.002	.018		.012	.410	+.000/-.012	.015		.035		1050	371	24067
CL-50	.500	.472	-.002	.022		.014	.467		.018		.045		1300	500	28030
CL-56	.562	.534		.022		.014	.529		.018		.045		1460	560	21060
CL-62	.625	.597		.022		.014	.591		.018		.045		1630	620	17850
CL-68	.687	.659		.022		.014	.652	+.000	.018		.045		1790	680	15340
CL-75	.750	.722		.022		.014	.715	-.013	.018		.045		1950	740	12350
CL-81	.812	.770		.026	+.002	.021	.762		.021	+.0015	.065		2460	1210	15380
CL-87	.875	.833	+.003	.026	-.000	.021	.825		.021	-.0015	.065		2660	1300	12800
CL-93	.937	.895	-.003	.026		.021	.886		.021		.065		2840	1390	11500
CL-100	1.000	.958		.026		.021	.949		.021		.065		3040	1480	9800
CL-106	1.062	1.018		.031		.022	1.008		.025		.088		3500	1650	11490
CL-112	1.125	1.081		.031		.022	1.071		.025		.088		3710	1750	9990
CL-118	1.187	1.143		.031		.022	1.132		.025		.088		3920	1850	9220
CL-125	1.250	1.206	+.004	.031		.022	1.194	+.000	.025		.088		4120	1940	8500
CL-131	1.312	1.268	-.004	.031		.022	1.255	-.015	.025		.088		4330	2040	7880
CL-137	1.375	1.331		.031		.022	1.318		.025		.088		4540	2140	7030
CL-143	1.437	1.393		.031		.022	1.379		.025		.088		4740	2240	6560
CL-150	1.500	1.456		.031		.022	1.442		.025		.088		4950	2330	5900
CL-156	1.562	1.505		.039		.029	1.488		.031		.118	+.004	6390	3200	7720
CL-162	1.625	1.568		.039		.029	1.550		.031		.118	-.004	6650	3330	7220
CL-168	1.687	1.630		.039		.029	1.612		.031		.118		6900	3460	6590
CL-175	1.750	1.693	+.005	.039		.029	1.674	+.000	.031		.118		7160	3590	6200
CL-181	1.812	1.755	-.005	.039		.029	1.736	-.020	.031		.118		7410	3710	5700
CL-187	1.875	1.818		.039		.029	1.798		.031		.118		7670	3840	5380
CL-193	1.937	1.880		.039		.029	1.859		.031		.118		7920	3970	5100
CL-200	2.000	1.943		.039		.029	1.922		.031		.118		8180	4100	4720
CL-206	2.062	1.986		.039		.038	1.963		.031		.158		8430	5540	5970
CL-212	2.125	2.049		.039		.038	2.026		.031		.158		8690	5710	5550
CL-218	2.187	2.111		.039		.038	2.087		.031		.158		8950	5870	5290
CL-225	2.250	2.174		.039		.038	2.149		.031	+.002	.158		9200	6040	5050
CL-231	2.312	2.236		.039	+.003	.038	2.211		.031	-.002	.158		9460	6210	4720
CL-237	2.375	2.299		.039	-.000	.038	2.273		.031		.158		9720	6380	4520
CL-243	2.437	2.361		.039		.038	2.335	+.000	.031		.158		9970	6550	4240
CL-250	2.500	2.424		.039		.038	2.397	-.025	.031		.158		10230	6720	4063
CL-256	2.562	2.486	+.006	.039		.038	2.458		.031		.158		10480	6880	3900
CL-262	2.625	2.549	-.006	.039		.038	2.521		.031		.158		10740	7050	3680
CL-268	2.687	2.611		.039		.038	2.582		.031		.158		10990	7220	3540
CL-275	2.750	2.674		.039		.038	2.644		.031		.158		11250	7390	3400
CL-281	2.812	2.736		.039		.038	2.706		.031		.158		11500	7550	3220
CL-287	2.875	2.799		.039		.038	2.768		.031		.158		11760	7720	3100
CL-293	2.937	2.861		.039		.038	2.830		.031		.158		12010	7890	2940
CL-300	3.000	2.924		.039		.038	2.892		.031		.158		12270	8060	2840
CL-306	3.062	2.970		.044		.046	2.938	+.000	.039		.188	+.005	15760	9960	3670
CL-312	3.125	3.033		.044		.046	3.001	-.030	.039		.188	-.005	16080	10160	3030

\* No Removal Notch.





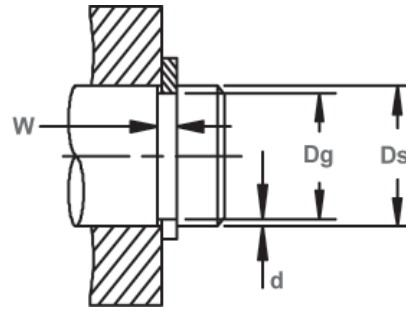
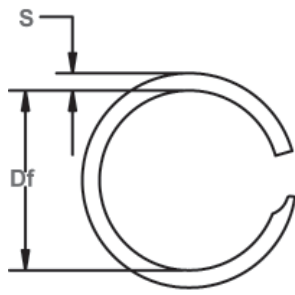

Free Diameter & Ring Measurements

Shaft Diameter & Groove Dimensions

RING NO.	SHAFT DIAMETER (In.)	GROOVE SIZE					RING SIZE				SECTION		THRUST LOAD (lbs.)		R.P.M. LIMITS Standard Material (Carbon Steel)
		DIAMETER		WIDTH		DEPTH	FREE DIAMETER			THICKNESS		RING Safety factor of 3	GROOVE Safety factor of 2		
		Dg	Tol.	W	Tol.	d	Df	Tol.	T	Tol.	S			Tol.	
CL-318	3.187	3.095		.044		.046	3.062		.039		.188		16400	10360	2930
CL-325	3.250	3.158		.044		.046	3.125		.039		.188		16720	10570	2790
CL-331	3.312	3.220		.044		.046	3.186		.039		.188		17040	10770	2700
CL-337	3.375	3.283		.044		.046	3.248		.039		.188		17370	10970	2630
CL-343	3.437	3.345		.044		.046	3.310		.039		.188		17690	11180	3500
CL-350	3.500	3.408	+ .006	.044	+ .003	.046	3.372	+ .000	.039		.188		18010	11380	2440
CL-356	3.562	3.47	- .006	.044	- .000	.046	3.433	- .030	.039		.188		18330	11580	2370
CL-362	3.625	3.533		.044		.046	3.496		.039		.188		18650	11790	2270
CL-368	3.687	3.595		.044		.046	3.557		.039		.188		18970	11990	2210
CL-375	3.750	3.658		.044		.046	3.620		.039		.188		19300	12190	2120
CL-381	3.812	3.720		.044		.046	3.681		.039		.188		19620	12400	2060
CL-387	3.875	3.783		.044		.046	3.743		.039		.188		19940	12600	2010
CL-393	3.937	3.845		.044		.046	3.805		.039		.188		20260	12800	1930
CL-400	4.000	3.908		.044		.046	3.867		.039		.188		20580	13010	1880
CL-412	4.125	4.015		.052		.055	3.973		.046		.225	+ .005	23850	16040	2090
CL-425	4.250	4.140		.052		.055	4.097		.046		.225	- .005	24570	16520	1960
CL-437	4.375	4.265		.052		.055	4.221		.046		.225		25290	17010	1850
CL-450	4.500	4.390		.052		.055	4.345	+ .000	.046		.225		26010	17500	1750
CL-462	4.625	4.515		.052		.055	4.468	- .035	.046		.225		26740	17980	1670
CL-475	4.750	4.640		.052		.055	4.592		.046	+ .002	.225		27460	18470	1580
CL-487	4.875	4.765	+ .007	.052		.055	4.715	- .002	.046	- .002	.225		28180	18950	1520
CL-500	5.000	4.890	- .007	.052		.055	4.839		.046		.225		28900	19440	1440
CL-525	5.250	5.119		.067	+ .004	.066	5.067		.061		.225		40240	24490	1310
CL-550	5.500	5.363		.067	- .000	.069	5.309		.061		.225		42160	26830	1190
CL-575	5.750	5.606		.067		.072	5.550		.061		.225		44080	29260	1090
CL-600	6.000	5.850		.067		.075	5.792	+ .000	.061		.225		45990	31810	
CL-625	6.250	6.094		.067		.078	6.033	- .045	.061		.265		47910	34460	
CL-650	6.500	6.338		.067		.081	6.275		.061		.265		49830	37220	
CL-675	6.750	6.581		.067		.085	6.515		.061		.265		51740	40560	
CL-700	7.000	6.825		.067		.088	6.757		.061		.265		53660	43540	
CL-725	7.250	7.069		.067		.091	6.998		.061		.300		55580	46640	
CL-750	7.500	7.313		.067		.094	7.240		.061		.300		57490	49830	
CL-775	7.750	7.556		.067		.097	7.480		.061		.300		59410	53140	
CL-800	8.000	7.800	+ .008	.067	- .008	.100	7.722	+ .000	.061		.300		61320	56550	
CL-825	8.250	8.044		.082		.103	7.964	- .060	.076		.345		78790	60070	
CL-850	8.500	8.288		.082		.106	8.205		.076		.345	+ .004	81180	63690	
CL-875	8.750	8.531		.082		.110	8.446		.076		.345	- .008	83570	68040	
CL-900	9.000	8.775		.082		.113	8.687		.076		.345		85950	71890	
CL-925	9.250	9.019		.082	+ .005	.116	8.929	+ .000	.076		.345		88340	75850	
CL-950	9.500	9.263		.082	- .005	.119	9.170	- .070	.076		.345		90730	79910	
CL-975	9.750	9.506		.082		.122	9.411		.076		.345		93120	84080	
CL-1000	10.000	9.750		.082		.125	9.653		.076		.345		95500	88360	

CONTACT FACTORY REGARDING MAX RPM LIMITS FOR LARGER DIAMETER RINGS



# KM Spiral Housing Rings

**Internal, Medium Duty**  
 These 2-turn rings provide 360° groove contact and are designed for applications with medium thrust loads.

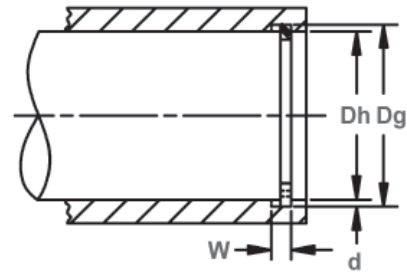
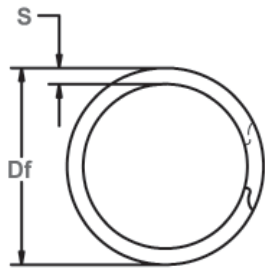

Free Diameter & Ring Measurements

Housing Diameter & Groove Dimensions

RING NO.	HOUSING DIAMETER (In.)	GROOVE SIZE					FREE DIAMETER		RING SIZE THICKNESS		SECTION		THRUST LOAD (lbs.)	
		DIAMETER		WIDTH		DEPTH							RING Safety factor of 3	GROOVE Safety factor of 2
		Dh	Dg	Tol.	W	Tol.	d	Df	Tol.	T	Tol.	S	Tol.	
KM-50	.500	.526		.030		.013	.532		.025		.045		2000	460
KM-51	.512	.538		.030		.013	.544		.025		.045		2050	470
KM-53	.531	.557		.030		.013	.564		.025		.045		2130	490
KM-56	.562	.588		.030		.013	.594		.025		.045		2250	520
KM-59	.594	.619	+ .002	.030		.013	.626		.025		.045		2380	550
KM-62	.625	.651	- .002	.030		.013	.658		.025		.045		2500	570
KM-65	.656	.682		.030		.013	.689		.025		.045		2630	600
KM-68	.687	.713		.030		.013	.720		.025		.045		2750	630
KM-71	.718	.744		.030		.013	.751		.025		.045		2870	660
KM-75	.750	.782		.036		.016	.790		.031		.065		3360	850
KM-77	.777	.808		.036		.016	.817	+ .013	.031		.065		3480	880
KM-78	.781	.812		.036	+ .003	.016	.821	- .000	.031		.065		3500	880
KM-81	.812	.843		.036	- .000	.016	.853		.031		.065		3640	920
KM-84	.843	.880		.036		.019	.889		.031		.065		3780	1130
KM-86	.866	.903		.036		.019	.913		.031		.065		3880	1160
KM-87	.875	.912	+ .003	.036		.019	.922		.031		.065		3920	1180
KM-90	.906	.943	- .003	.036		.019	.949		.031	+ .002	.065	+ .003	4060	1220
KM-93	.938	.975		.036		.019	.986		.031	- .002	.065	- .005	4200	1260
KM-96	.968	1.011		.042		.021	1.025		.037		.075		5180	1440
KM-98	.987	1.030		.042		.021	1.041		.037		.075		5280	1470
KM-100	1.000	1.043		.042		.021	1.054		.037		.075		5350	1480
KM-102	1.023	1.066		.042		.021	1.078		.037		.075		5470	1520
KM-103	1.031	1.074		.042		.021	1.084		.037		.075		5510	1530
KM-106	1.062	1.104		.042		.021	1.117		.037		.075		5680	1580
KM-109	1.093	1.135		.042		.021	1.147		.037		.075		5840	1620
KM-112	1.125	1.167		.042		.021	1.180		.037		.075		6020	1670
KM-115	1.156	1.198		.042		.021	1.210		.037		.075		6180	1720
KM-118	1.188	1.236		.048		.024	1.249		.043		.085		7380	2020
KM-121	1.218	1.266		.048		.024	1.278		.043		.085		7570	2070
KM-125	1.250	1.298	+ .004	.048		.024	1.312		.043		.085		7770	2120
KM-128	1.281	1.329	- .004	.048		.024	1.342	+ .015	.043		.085		7960	2170
KM-131	1.312	1.360		.048	+ .004	.024	1.374	- .000	.043		.085		8150	2230
KM-134	1.343	1.395		.048	- .000	.026	1.408		.043		.085		8350	2470
KM-137	1.375	1.427		.048		.026	1.442		.043		.095		8540	2530
KM-140	1.406	1.458		.048		.026	1.472		.043		.095		8740	2580
KM-143	1.437	1.489		.048		.026	1.504		.043		.095		8930	2640
KM-145	1.456	1.508		.048		.026	1.523		.043		.095		9050	2680
KM-146	1.468	1.520		.048		.026	1.535		.043		.095		9120	2700
KM-150	1.500	1.552		.048		.026	1.567		.043		.095		9320	2760

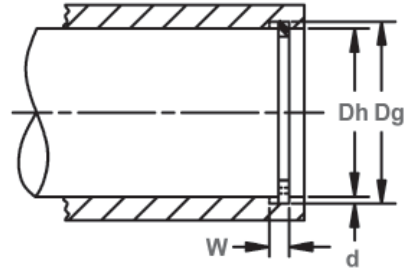
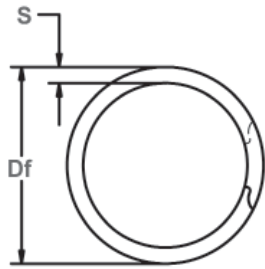

Free Diameter & Ring Measurements

Housing Diameter & Groove Dimensions

RING NO.	HOUSING DIAMETER		GROOVE SIZE				FREE DIAMETER			RING SIZE THICKNESS		SECTION		THRUST LOAD (lbs.)	
	(In.)	Dg	Diameter	WIDTH		DEPTH	Df	Tol.	T	Tol.	S	Tol.	RING Safety factor of 3	GROOVE Safety factor of 2	
				Dh	Tol.										d
KM-156	1.562	1.617		.056		.028	1.634		.049		.108		10100	3090	
KM-157	1.574	1.633		.056		.030	1.649		.049		.108		10180	3340	
KM-162	1.625	1.684		.056		.030	1.701		.049		.108		10510	3350	
KM-165	1.653	1.712		.056		.030	1.730		.049		.108		10690	3510	
KM-168	1.687	1.750	+.005 -.005	.056		.031	1.768	+.020 -.000	.049		.118		10910	3700	
KM-175	1.750	1.813		.056		.031	1.834		.049		.118		11310	3840	
KM-181	1.813	1.875		.056		.031	1.894		.049		.118		11720	3970	
KM-185	1.850	1.917		.056		.034	1.937		.049		.118		11960	4450	
KM-187	1.875	1.942		.056		.034	1.960		.049		.118		12120	4510	
KM-193	1.938	2.005		.056		.034	2.025		.049		.118		12530	4660	
KM-200	2.000	2.071		.056		.035	2.091		.049		.128		12930	4950	
KM-204	2.047	2.118		.056		.035	2.138		.049		.128		18240	5060	
KM-206	2.062	2.132		.056		.035	2.154		.049		.128	+.003 -.005	13330	5100	
KM-212	2.125	2.195		.056		.035	2.217		.049		.128		13740	5260	
KM-216	2.165	2.239		.056	+.004 -.000	.037	2.260		.049		.138	14000	5660		
KM-218	2.188	2.262		.056		.037	2.284		.049		.138	14150	5720		
KM-225	2.250	2.324		.056		.037	2.347		.049		.138	14550	5890		
KM-231	2.312	2.390		.056		.039	2.413		.049		.138	14950	6370		
KM-237	2.375	2.453		.056		.039	2.476		.049		.138	15360	6550		
KM-243	2.437	2.519		.056		.041	2.543		.049		.148	15760	7060		
KM-244	2.440	2.522		.056		.041	2.546		.049		.148	15780	7070		
KM-250	2.500	2.582		.056		.041	2.606	+.025 -.000	.049	+.003 -.003	.148	16160	7250		
KM-253	2.531	2.617		.056		.043	2.641		.049		.148	16360	7690		
KM-256	2.562	2.648		.056		.043	2.673		.049		.148	16560	7790		
KM-262	2.625	2.711		.056		.043	2.736		.049		.148	16970	7980		
KM-267	2.677	2.767	+.006 -.006	.056		.045	2.789		.049		.158	17310	8520		
KM-268	2.688	2.778		.056		.045	2.803		.049		.158	17380	8550		
KM-275	2.750	2.841		.056		.045	2.865		.049		.158	17780	8750		
KM-281	2.813	2.903		.056		.045	2.929		.049		.158	18190	8950		
KM-283	2.834	2.928		.056		.047	2.954		.049		.168	18320	9520		
KM-287	2.875	2.969		.056		.047	2.995		.049		.168	18590	9550		
KM-293	2.937	3.031		.056		.047	3.058		.049		.168	18990	9760		
KM-295	2.952	3.046		.056		.047	3.073		.049		.168	19090	9810		
KM-300	3.000	3.096		.068		.048	3.122		.061		.168	24150	10180		
KM-306	3.062	3.158		.068		.048	3.186		.061		.168	24650	10390		
KM-312	3.125	3.223		.068		.048	3.251		.061		.178	25150	10600		
KM-314	3.149	3.247		.068	+.005 -.000	.048	3.276		.061		.178	25350	10680		
KM-318	3.187	3.283		.068		.048	3.311	+.030 -.000	.061		.178	25650	10810		
KM-325	3.250	3.350		.068		.050	3.379		.061		.178	26160	11490		
KM-331	3.312	3.416		.068		.052	3.446		.061		.188	26660	12170		
KM-334	3.346	3.450		.068		.052	3.479		.061		.188	26930	12300		
KM-337	3.375	3.479		.068		.052	3.509		.061		.188	27170	12410		



# KM Spiral Housing Rings

**Internal, Medium Duty**  
 These 2-turn rings provide 360° groove contact and are designed for applications with medium thrust loads.

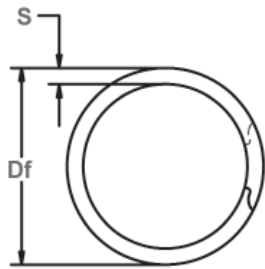

Free Diameter & Ring Measurements

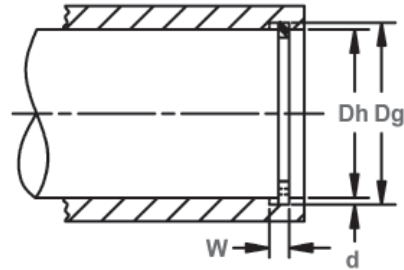

Housing Diameter & Groove Dimensions

RING NO.	HOUSING DIAMETER		GROOVE SIZE				RING SIZE			SECTION		THRUST LOAD (lbs.)		
	Dh (In.)	Dg	DIAMETER		WIDTH	DEPTH	FREE DIAMETER		THICKNESS		S	Tol.	RING Safety factor of 3	GROOVE Safety factor of 2
		Tol.	W	Tol.	d	Df	Tol.	T	Tol.					
KM-343	3.437	3.543		.068		.053	3.574		.061		.188		27660	12880
KM-350	3.500	3.606		.068		.053	3.636		.061		.188		28170	13110
KM-354	3.543	3.653		.068		.055	3.684		.061		.198		28520	13770
KM-356	3.562	3.672		.068		.055	3.703		.061		.198		28670	13850
KM-362	3.625	3.737		.068		.056	3.769		.061		.198		29180	14350
KM-368	3.687	3.799		.068		.056	3.832	.+.030	.061		.198		29680	14600
KM-374	3.740	3.852		.068		.056	3.885	-.000	.061		.198		30100	14800
KM-375	3.750	3.862		.068		.056	3.894		.061	.+.003	.198		30180	14840
KM-381	3.812	3.930		.068		.059	3.963		.061	-.003	.208		30680	15900
KM-387	3.875	3.993		.068		.059	4.025		.061		.208		31190	16160
KM-393	3.938	4.056		.068		.059	4.089		.061		.208		31700	16420
KM-400	4.000	4.124		.068		.062	4.157		.061		.218		32200	17530
KM-406	4.063	4.187		.068		.062	4.222		.061		.218		32700	17810
KM-412	4.125	4.249	.+.006	.068		.062	4.284		.061		.218		33200	18080
KM-418	4.188	4.311	-.006	.068	.+.005	.062	4.347		.061		.218		33710	18350
KM-425	4.250	4.380		.068	-.000	.065	4.416		.061		.228		34210	19530
KM-431	4.312	4.442		.068		.065	4.479		.061		.228		34710	19810
KM-433	4.330	4.460		.068		.065	4.497		.061		.228	.+.004	34850	19900
KM-437	4.375	4.505		.068		.065	4.543		.061		.228	-.006	35210	20100
KM-443	4.437	4.573		.068		.068	4.611		.061		.238		35710	21330
KM-450	4.500	4.636		.068		.068	4.674		.061		.238		36220	21630
KM-452	4.527	4.663		.068		.068	4.701		.061		.238		36440	21760
KM-456	4.562	4.698		.068		.068	4.737	.+.035	.061		.238		36720	21930
KM-462	4.625	4.765		.079		.070	4.803	-.000	.072		.250		43940	22890
KM-468	4.687	4.827		.079		.070	4.867		.072		.250		44530	23190
KM-472	4.724	4.864		.079		.070	4.903		.072		.250		44880	23370
KM-475	4.750	4.890		.079		.070	4.930		.072		.250		45130	23500
KM-481	4.812	4.952		.079		.070	4.993		.072		.250		45720	23810
KM-487	4.875	5.015		.079		.070	5.055		.072		.250		46310	24120
KM-492	4.921	5.061		.079		.070	5.102		.072		.250		46750	24350
KM-493	4.937	5.081		.079		.072	5.122		.072	.+.004	.250		46900	25130
KM-500	5.000	5.144		.079		.072	5.185		.072	-.004	.250		47500	25450
KM-511	5.118	5.262		.079		.072	5.304		.072		.250		48620	26050
KM-512	5.125	5.269		.079		.072	5.311		.072		.250		48690	26100
KM-525	5.250	5.393		.079		.072	5.436		.072		.250		49880	26720
KM-537	5.375	5.522		.079		.074	5.566		.072		.250		51060	28120
KM-550	5.500	5.647	.+.007	.079		.074	5.693	.+.045	.072		.250		52250	28770
KM-551	5.511	5.658	-.007	.079		.074	5.703	-.000	.072		.250		52360	28830
KM-562	5.625	5.772		.079		.074	5.818		.072		.250		53440	29400
KM-570	5.708	5.861		.079		.077	5.909		.072		.250		54230	31070
KM-575	5.750	5.903		.079		.077	5.950		.072		.250		54630	31300



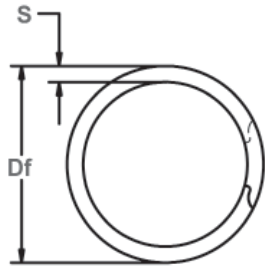

Free Diameter & Ring Measurements

Housing Diameter & Groove Dimensions

RING NO.	HOUSING DIAMETER (In.)	GROOVE SIZE					FREE DIAMETER				RING SIZE THICKNESS		SECTION		THRUST LOAD (lbs.)	
		DIAMETER		WIDTH		DEPTH	FREE DIAMETER			THICKNESS		SECTION		RING Safety factor of 3	GROOVE Safety factor of 2	
		Dg	Tol.	W	Tol.	d	Df	Tol.	T	Tol.	S	Tol.				
KM-587	5.875	6.028	+.007	.079	+.005	.077	6.077		.072		.250	+.004	55810	31980		
KM-590	5.905	6.058	-.007	.079	-.000	.077	6.106	+.045	.072		.250	-.006	56100	32140		
KM-600	6.000	6.153		.079		.077	6.202	-.000	.072		.250		57000	32660		
KM-612	6.125	6.297		.094		.086	6.349		.086		.312		69500	37200		
KM-625	6.250	6.422		.094		.086	6.474		.086		.312		70920	37990		
KM-629	6.299	6.471		.094		.086	6.524		.086		.312		71480	38290		
KM-637	6.375	6.547		.094		.086	6.601		.086		.312		72340	38750		
KM-650	6.500	6.672		.094		.086	6.726		.086		.312		73760	39510		
KM-662	6.625	6.807		.094		.091	6.863	+.055	.086		.312		75180	42620		
KM-669	6.692	6.874		.094		.091	6.931	-.000	.086		.312		75940	43050		
KM-675	6.750	6.932		.094		.091	6.987		.086		.312		76600	43420		
KM-687	6.875	7.057		.094		.091	7.114		.086		.312		78010	44220		
KM-700	7.000	7.182		.094		.091	7.239		.086		.312		79430	45030		
KM-708	7.086	7.278		.094		.096	7.337		.086		.312		80410	48080		
KM-712	7.125	7.317		.094		.096	7.376		.086		.312		80850	48350		
KM-725	7.250	7.442		.094		.096	7.501		.086		.312		82270	49200		
KM-737	7.375	7.567		.094		.096	7.628		.086		.312		83690	50050		
KM-748	7.480	7.672		.094		.096	7.734		.086		.312	+.004	84880	50760		
KM-750	7.500	7.692	+.008	.094	+.006	.096	7.754		.086		.312	-.008	85110	50890		
KM-762	7.625	7.827	-.008	.094	-.000	.101	7.890		.086		.312		86520	54440		
KM-775	7.750	7.952		.094		.101	8.014		.086	+.004	.312		87940	55330		
KM-787	7.875	8.077		.094		.101	8.131		.086	-.004	.312		89360	63360		
KM-800	8.000	8.202		.094		.101	8.266		.086		.312		90780	57110		
KM-825	8.250	8.462		.094		.106	8.528		.086		.375		93620	61820		
KM-826	8.267	8.479		.094		.106	8.546		.086		.375		93810	61940		
KM-846	8.464	8.676		.094		.106	8.744	+.065	.086		.375		96050	63420		
KM-850	8.500	8.712		.094		.106	8.780	-.000	.086		.375		96450	63690		
KM-875	8.750	8.972		.094		.111	9.041		.086		.375		99290	68650		
KM-885	8.858	9.080		.094		.111	9.151		.086		.375		100520	69500		
KM-900	9.000	9.222		.094		.111	9.293		.086		.375		102130	70620		
KM-905	9.055	9.287		.094		.116	9.359		.086		.375		102750	74250		
KM-925	9.250	9.482		.094		.116	9.555		.086		.375		104960	75850		
KM-944	9.448	9.680		.094		.116	9.755		.086		.375		107210	77470		
KM-950	9.500	9.732		.094		.116	9.806		.086		.375		107800	77900		
KM-975	9.750	9.992		.094		.121	10.068		.086		.375		110640	83390		
KM-1000	10.000	10.242		.094		.121	10.320		.086		.375		113470	85530		
KM-1025	10.250	10.502		.094		.126	10.582		.086		.375		116310	91290		
KM-1050	10.500	10.752		.094		.126	10.834		.086		.375		119150	93520		
KM-1075	10.750	11.012		.094		.131	11.095		.086		.375		121990	99540		
KM-1100	11.000	11.262		.094		.131	11.347		.086		.375		124820	101860		

# CM Spiral Shaft Rings

**External, Medium Duty**  
 These 2-turn rings provide 360° groove contact and are designed for applications with medium thrust loads.

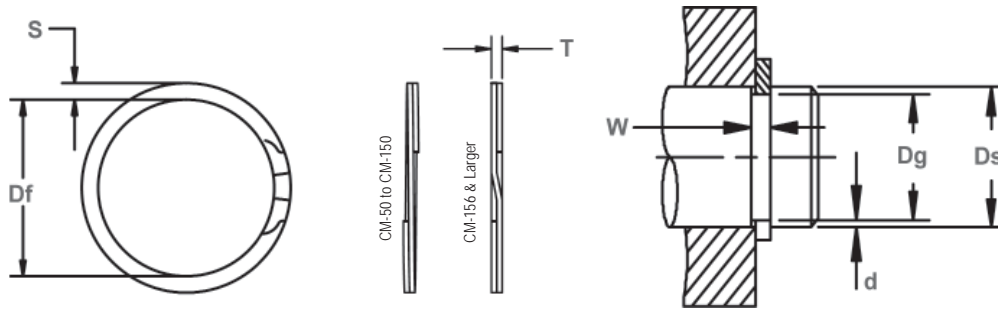

Free Diameter & Ring Measurements

Shaft Diameter & Groove Dimensions

RING NO.	SHAFT DIAMETER (In.)	GROOVE SIZE					FREE DIAMETER			RING SIZE THICKNESS		SECTION		THRUST LOAD (lbs.)		R.P.M. LIMITS Standard Material (Carbon Steel)
		DIAMETER		WIDTH		DEPTH	DIAMETER		THICKNESS		SECTION		RING Safety factor of 3	GROOVE Safety factor of 2		
		Ds	Dg	Tol.	W	Tol.	d	Df	Tol.	T	Tol.	S	Tol.			
CM-50	.500	.474		.030		.013	.467		.025		.045		2000	460	24650	
CM-53	.531	.505	+ .002	.030		.013	.498		.025		.045		2130	490	21280	
CM-55	.551	.525	- .002	.030		.013	.518		.025		.045		2210	510	19440	
CM-56	.562	.536		.030		.013	.529		.025		.045		2250	520	18520	
CM-59	.594	.569		.030		.013	.561		.025		.045		2380	550	17290	
CM-62	.625	.594		.030		.016	.585		.025		.055		2500	710	19500	
CM-65	.656	.625		.030		.016	.617		.025		.055		2630	740	16270	
CM-66	.669	.638		.030		.016	.629		.025		.055		2680	760	16510	
CM-68	.687	.656		.030		.016	.647		.025		.055		2750	780	15470	
CM-71	.718	.687		.030		.016	.679	+ .000	.025		.055		2880	810	13050	
CM-75	.750	.719		.036		.016	.710	- .013	.031		.065		3360	850	14290	
CM-78	.781	.750	+ .003	.036	+ .003	.016	.741		.031		.065		3500	880	12960	
CM-81	.812	.781	- .003	.036	- .000	.016	.771		.031		.065		3640	920	12470	
CM-84	.843	.812		.036		.016	.803		.031		.065		3780	950	10770	
CM-87	.875	.838		.036		.019	.828		.031		.065		3920	1180	10570	
CM-90	.906	.869		.036		.019	.860		.031		.065		4060	1220	9180	
CM-93	.937	.900		.036		.019	.889		.031	+ .002	.065	+ .003	4200	1260	9400	
CM-96	.968	.925		.042		.021	.916		.037	- .002	.075	- .005	5180	1440	8920	
CM-98	.984	.941		.042		.021	.930		.037		.075		5260	1460	9530	
CM-100	1.000	.957		.042		.021	.946		.037		.075		5350	1480	9160	
CM-102	1.023	.980		.042		.021	.968		.037		.075		5470	1520	9070	
CM-103	1.031	.988		.042		.021	.978		.037		.075		5510	1530	8080	
CM-106	1.062	1.020		.042		.021	1.007		.037		.075		5680	1580	8610	
CM-109	1.093	1.051		.042		.021	1.040		.037		.075		5840	1620	7350	
CM-112	1.125	1.083		.042		.021	1.070		.037		.075		6020	1670	7470	
CM-115	1.156	1.114		.042		.021	1.102		.037		.075		6180	1720	6700	
CM-118	1.188	1.140		.048		.024	1.127		.043		.085		7380	2020	7350	
CM-121	1.218	1.170		.048		.024	1.159		.043		.085		7570	2070	6340	
CM-125	1.250	1.202	+ .004	.048		.024	1.188	+ .000	.043		.085		7770	2120	6750	
CM-128	1.281	1.233	- .004	.048		.024	1.221	- .015	.043		.085		7960	2170	5860	
CM-131	1.312	1.264		.048	+ .004	.024	1.251		.043		.095		8150	2230	6310	
CM-134	1.343	1.295		.048	- .000	.024	1.282		.043		.095		8350	2280	5960	
CM-137	1.375	1.323		.048		.026	1.308		.043		.095		8540	2530	6110	
CM-140	1.406	1.354		.048		.026	1.340		.043		.095		8740	2580	5580	
CM-143	1.437	1.385		.048		.026	1.370		.043		.095		8930	2640	5490	
CM-146	1.468	1.416		.048		.026	1.402		.043		.095		9120	2700	5020	
CM-150	1.500	1.448		.048		.026	1.433		.043		.095		9320	2760	4940	

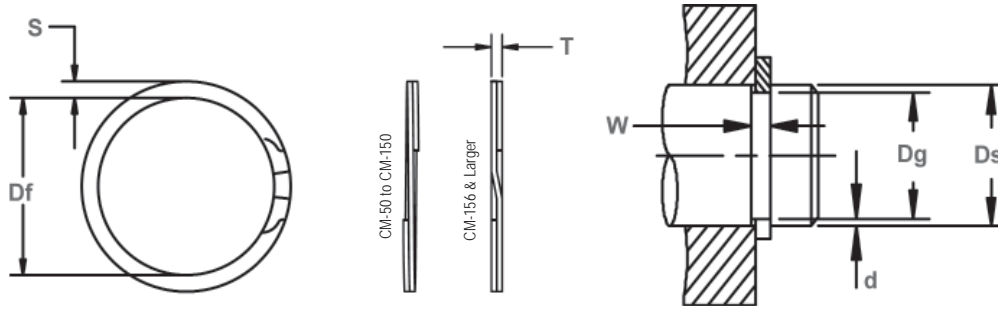

Free Diameter & Ring Measurements

Shaft Diameter & Groove Dimensions

RING NO.	SHAFT DIAMETER (In.)	GROOVE SIZE					FREE DIAMETER			RING SIZE THICKNESS		SECTION		THRUST LOAD (lbs.)		R.P.M. LIMITS Standard Material (Carbon Steel)
		DIAMETER		WIDTH		DEPTH							RING Safety factor of 3	GROOVE Safety factor of 2		
		Ds	Dg	Tol.	W	Tol.	d	Df	Tol.	T	Tol.	S	Tol.			
CM-156	1.562	1.507		.056		.028	1.490		.049		.108		10100	3090	5343	
CM-157	1.575	1.520		.056		.028	1.503		.049		.108		10190	3120	5240	
CM-162	1.625	1.566		.056		.030	1.549		.049		.108		10510	3450	4880	
CM-168	1.687	1.628		.056		.030	1.610		.049		.118		10910	3580	4930	
CM-175	1.750	1.691	+.005 -.005	.056		.030	1.673		.049		.118		11310	3710	4510	
CM-177	1.771	1.708		.056		.032	1.690		.049		.118		11450	4010	4410	
CM-181	1.813	1.749		.056		.032	1.730	+.000 -.020	.049		.118		11720	4100	4290	
CM-187	1.875	1.808		.056		.034	1.789		.049		.128		12120	4510	4240	
CM-193	1.938	1.871		.056		.034	1.844		.049		.128	+.003 -.005	12530	4660	4020	
CM-196	1.969	1.902		.056		.034	1.882		.049		.128		12730	4730	3860	
CM-200	2.000	1.929		.056		.035	1.909		.049		.128		12930	4950	3740	
CM-206	2.062	1.992		.056		.035	1.971		.049		.128		13330	5100	3550	
CM-212	2.125	2.051		.056	+.004 -.000	.037	2.029		.049		.128		13740	5560	3400	
CM-215	2.156	2.082		.056		.037	2.060		.049		.138		13940	5640	3490	
CM-216	2.165	2.091		.056		.037	2.070		.049	+.003 -.003	.138		14000	5660	3370	
CM-218	2.188	2.113		.056		.037	2.092		.049		.138		14150	5720	3290	
CM-225	2.250	2.176		.056		.037	2.153		.049		.138		14550	5890	3220	
CM-231	2.312	2.234		.056		.039	2.211		.049		.138		14950	6370	3020	
CM-236	2.362	2.284		.056		.039	2.261	+.000 -.025	.049		.138		15270	6510	2870	
CM-237	2.375	2.297		.056		.039	2.273		.049		.138		15360	6550	2890	
CM-243	2.437	2.355		.056		.041	2.331		.049		.148		15760	7060	2920	
CM-250	2.500	2.418	+.006 -.006	.056		.041	2.394		.049		.148		16160	7250	2750	
CM-255	2.559	2.473		.056		.043	2.449		.049		.148		16550	7780	2600	
CM-256	2.562	2.476		.056		.043	2.452		.049		.148		16560	7790	2600	
CM-262	2.625	2.539		.056		.043	2.514		.049		.148		16970	7980	2500	
CM-268	2.688	2.597		.056		.045	2.572		.049		.158		17380	8550	2470	
CM-275	2.750	2.660		.056		.045	2.635		.049		.158		17780	8750	2340	
CM-281	2.813	2.722		.056		.045	2.696		.049		.168	+.004 -.006	18190	8950	2380	
CM-287	2.875	2.781		.056		.047	2.755		.049		.168		18590	9550	2260	
CM-293	2.937	2.843		.056		.047	2.817		.049		.168		18990	9760	2140	
CM-295	2.952	2.858		.056		.047	2.831	+.000 -.030	.049		.168		19090	9810	2160	
CM-300	3.000	2.904		.068		.048	2.877		.061		.168		24150	10180	2080	
CM-306	3.062	2.966		.068		.048	2.938		.061		.168		24650	10390	2020	
CM-312	3.125	3.027		.068	+.005 -.000	.049	3.000		.061		.178		25150	10820	1980	
CM-314	3.149	3.051		.068		.049	3.023		.061		.178		25350	10910	1980	
CM-318	3.187	3.089		.068		.049	3.061		.061		.178		25650	11040	1930	
CM-325	3.250	3.150		.068		.050	3.121		.061		.178		26160	11490	1870	

# CM Spiral Shaft Rings

**External, Medium Duty**  
 These 2-turn rings provide 360° groove contact and are designed for applications with medium thrust loads.

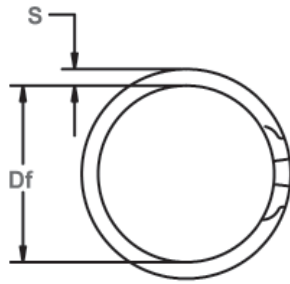

Free Diameter & Ring Measurements

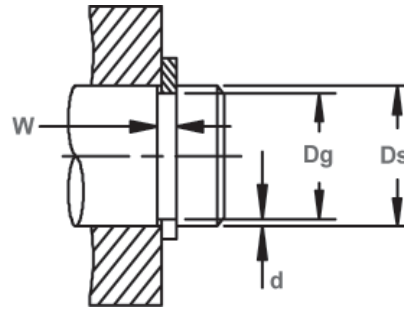
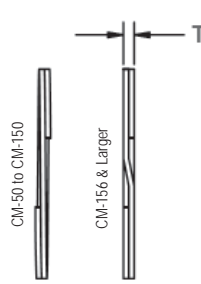

Shaft Diameter & Groove Dimensions

RING NO.	SHAFT DIAMETER (In.)	GROOVE SIZE					FREE DIAMETER			RING SIZE THICKNESS		SECTION		THRUST LOAD (lbs.)		R.P.M. LIMITS Standard Material (Carbon Steel)
		DIAMETER		WIDTH		DEPTH							RING Safety factor of 3	GROOVE Safety factor of 2		
		Ds	Dg	Tol.	W	Tol.	d	Df	Tol.	T	Tol.	S	Tol.			
CM-331	3.312	3.208		.068		.052	3.180		.061		.188		26660	12170	1840	
CM-334	3.343	3.239		.068		.052	3.210	+.000	.061		.188		26910	12290	1840	
CM-337	3.375	3.271		.068		.052	3.242	-.030	.061		.188		27170	12410	1790	
CM-343	3.437	3.331		.068		.053	3.301		.061		.188		27660	12880	1750	
CM-350	3.500	3.394		.068		.053	3.363		.061		.188		28170	13110	1700	
CM-354	3.543	3.433		.068		.055	3.402		.061		.198		28520	13770	1730	
CM-356	3.562	3.452		.068		.055	3.422		.061		.198		28670	13850	1680	
CM-362	3.625	3.515		.068		.055	3.483		.061		.198		29180	14090	1660	
CM-368	3.687	3.575		.068		.056	3.543		.061		.198		29680	14600	1600	
CM-374	3.740	3.628		.068		.056	3.597		.061		.198		30100	14800	1520	
CM-375	3.750	3.638		.068		.056	3.606		.061		.198		30180	14840	1530	
CM-381	3.812	3.700		.068		.056	3.668		.061	+.003	.198		30680	15090	1470	
CM-387	3.875	3.757		.068		.059	3.724		.061	-.003	.208		31190	16160	1500	
CM-393	3.938	3.820		.068		.059	3.784		.061		.208		31700	16420	1510	
CM-400	4.000	3.876	+.006	.068	+.005	.062	3.842		.061		.218	+.004	32200	17530	1470	
CM-406	4.063	3.939	-.006	.068	-.000	.062	3.906		.061		.218	-.006	32700	17810	1400	
CM-412	4.125	4.000		.068		.062	3.967		.061		.218		33200	18080	1350	
CM-413	4.134	4.010		.068		.062	3.975		.061		.218		33270	18120	1380	
CM-418	4.188	4.058		.068		.065	4.030	+.000	.061		.218		33710	19240	1360	
CM-425	4.250	4.120		.068		.065	4.084	-.040	.061		.228		34210	19530	1360	
CM-431	4.312	4.182		.068		.065	4.147		.061		.228		34710	19810	1300	
CM-433	4.331	4.200		.068		.065	4.164		.061		.228		34860	19900	1300	
CM-437	4.375	4.245		.068		.065	4.208		.061		.228		35210	20100	1290	
CM-443	4.437	4.307		.068		.065	4.271		.061		.228		35710	20390	1230	
CM-450	4.500	4.364		.068		.068	4.326		.061		.238		36220	21630	1270	
CM-456	4.562	4.422		.079		.070	4.384		.072		.250		43340	22570	1280	
CM-462	4.625	4.485		.079		.070	4.447		.072		.250		43940	22890	1240	
CM-468	4.687	4.547		.079		.070	4.508		.072		.250		44530	23190	1220	
CM-472	4.724	4.584		.079		.070	4.546		.072		.250		44880	23370	1180	
CM-475	4.750	4.610		.079		.070	4.571		.072		.250		45130	23500	1180	
CM-481	4.812	4.672		.079		.070	4.633		.072	+.004	.250		45720	23810	1140	
CM-487	4.875	4.735		.079		.070	4.695		.072	-.004	.250		46310	24120	1120	
CM-493	4.937	4.797		.079		.070	4.757		.072		.250		46900	24430	1090	
CM-500	5.000	4.856		.079		.072	4.820		.072		.250		47500	25450	1050	
CM-511	5.118	4.974		.079		.072	4.934		.072		.250		48620	26050	1000	
CM-512	5.125	4.981		.079		.072	4.939		.072		.250		48690	26080	1020	



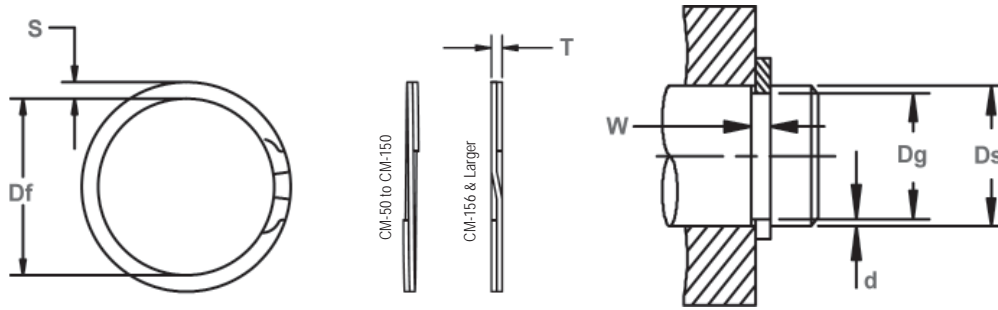

Free Diameter & Ring Measurements

Shaft Diameter & Groove Dimensions

RING NO.	SHAFT DIAMETER (In.)	GROOVE SIZE					FREE DIAMETER			RING SIZE THICKNESS		SECTION		THRUST LOAD (lbs.)		R.P.M. LIMITS Standard Material (Carbon Steel)
		DIAMETER		WIDTH		DEPTH							RING Safety factor of 3	GROOVE Safety factor of 2		
		Ds	Dg	Tol.	W	Tol.	d	Df	Tol.	T	Tol.	S	Tol.			
CM-525	5.250	5.107		.079		.072	5.064		.072		.250		49880	26720	970	
CM-537	5.375	5.228		.079		.074	5.187		.072		.250		51060	28120	900	
CM-550	5.500	5.353		.079		.074	5.308		.072		.250		52250	28770	890	
CM-551	5.511	5.364	+ .007	.079	+ .005	.074	5.320		.072		.250	+ .004	52360	28830	870	
CM-562	5.625	5.478	- .007	.079	- .000	.074	5.433	+ .000	.072		.250	- .006	53440	29420	840	
CM-575	5.750	5.597		.079		.077	5.550	- .050	.072		.250		54630	31300	820	
CM-587	5.875	5.722		.079		.077	5.674		.072		.250		55810	31980		
CM-590	5.905	5.752		.079		.077	5.705		.072		.250		56100	32140		
CM-600	6.000	5.847		.079		.077	5.798		.072		.250		57000	32660		
CM-612	6.125	5.953		.094		.086	5.903		.086		.312		69500	37230		
CM-625	6.250	6.078		.094		.086	6.026		.086		.312		70920	37990		
CM-629	6.299	6.127		.094		.086	6.076		.086		.312		71480	38290		
CM-637	6.375	6.203		.094		.086	6.152		.086		.312		72340	38750		
CM-650	6.500	6.328		.094		.086	6.274		.086		.312		73760	39510		
CM-662	6.625	6.443		.094		.091	6.390	+ .000	.086		.312		75180	42620		
CM-675	6.750	6.568		.094		.091	6.513	- .060	.086		.312		76600	43420		
CM-687	6.875	6.693		.094		.091	6.638		.086		.312		78010	44220		
CM-700	7.000	6.818		.094		.091	6.761		.086		.312		79430	45030		
CM-712	7.125	6.933		.094		.096	6.877		.086	+ .004	.312		80850	48350		
CM-725	7.250	7.058		.094		.096	6.999		.086	- .004	.312		82270	49200		
CM-737	7.375	7.183		.094		.096	7.125		.086		.312		83690	50050		
CM-750	7.500	7.308	+ .008	.094	+ .006	.096	7.250		.086		.312	+ .004	85110	50890		
CM-762	7.625	7.423	- .008	.094	- .000	.101	7.363		.086		.312	- .008	86520	54440		
CM-775	7.750	7.548		.094		.101	7.486		.086		.312		87940	55330		
CM-787	7.875	7.673		.094		.101	7.611		.086		.312		89360	56220		
CM-800	8.000	7.798		.094		.101	7.734		.086		.312		90780	57110		
CM-825	8.250	8.038		.094		.106	7.972		.086		.375		93620	61820		
CM-850	8.500	8.288		.094		.106	8.220	+ .000	.086		.375		96450	63690		
CM-875	8.750	8.528		.094		.111	8.459	- .070	.086		.375		99290	68650		
CM-900	9.000	8.778		.094		.111	8.707		.086		.375		102130	70620		
CM-925	9.250	9.018		.094		.116	8.945		.086		.375		104960	75850		
CM-950	9.500	9.268		.094		.116	9.194		.086		.375		107800	77900		
CM-975	9.750	9.508		.094		.121	9.432		.086		.375		110640	83390		
CM-1000	10.000	9.758		.094		.121	9.680		.086		.375		113470	85530		
CM-1025	10.250	9.998		.094		.126	9.918		.086		.375		116310	91290		
CM-1050	10.500	10.248		.094		.126	10.166		.086		.375		119150	93520		
CM-1075	10.750	10.488		.094		.131	10.405		.086		.375		121990	99540		
CM-1100	11.000	10.738		.094		.131	10.653		.086		.375		124820	101860		

CONTACT FACTORY REGARDING MAX RPM LIMITS FOR LARGER DIAMETER RINGS.



# KR Spiral Housing Rings

## Internal, Medium-Heavy Duty

These 2-turn and multi-turn rings provide 360° groove contact and are designed for applications with medium-high thrust loads.

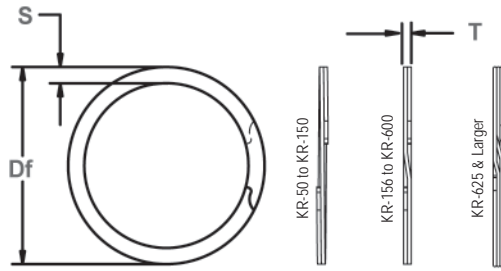

Free Diameter & Ring Measurements

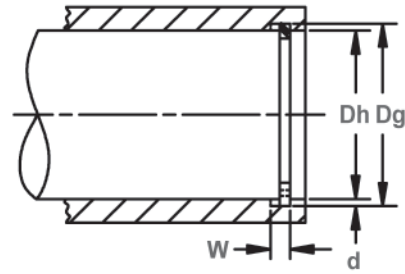

Housing Diameter & Groove Dimensions

RING NO.	HOUSING DIAMETER (In.)	GROOVE SIZE					RING SIZE						THRUST LOAD (lbs.)			
		DIAMETER			WIDTH		DEPTH		FREE DIAMETER		THICKNESS		SECTION		RING Safety factor of 3	GROOVE Safety factor of 2
		Dh	Dg	Tol.	W	Tol.	d	Df	Tol.	T	Tol.	S	Tol.			
KR-50	.500	.524	+.002/-0.002	.039		.012	.529		.035		.045		2530	420		
KR-51	.512	.536	+.003 -.003	.039	+.003 -.000	.012	.541	+.013 -.000	.035	+.002 -.002	.045	+.004 -.004	2590	430		
KR-56	.562	.592		.039		.015	.597		.035		.045		2840	600		
KR-62	.625	.659		.039		.017	.665		.035		.045		3160	750		
KR-68	.688	.724		.039		.018	.730		.035		.055		3480	880		
KR-75	.750	.790		.039		.020	.796		.035		.055		3790	1060		
KR-77	.777	.819		.046		.021	.825		.042		.065		4720	1150		
KR-81	.812	.857		.046		.023	.864		.042		.065		4930	1320		
KR-86	.866	.912		.046		.023	.919		.042		.065		5260	1410		
KR-87	.875	.922		.046		.024	.929		.042		.065		5310	1480		
KR-90	.901	.950		.046		.025	.957		.042		.065		5470	1590		
KR-93	.938	.989	.046	.026	.997	.042	.075	5690	1720							
KR-100	1.000	1.055	.046	.028	1.063	.042	.075	6070	1980							
KR-102	1.023	1.079	+.004 -.004	.046	+.004 -.000	.028	1.087	+.015 -.000	.042	+.003 -.003	.075	+.005 -.005	6210	2030		
KR-106	1.062	1.120		.056		.029	1.129		.050		.078		7010	2180		
KR-112	1.125	1.185		.056		.030	1.195		.050		.078		7420	2390		
KR-118	1.188	1.250		.056		.031	1.260		.050		.088		7840	2600		
KR-125	1.250	1.320		.056		.035	1.330		.050		.093		8250	3090		
KR-131	1.312	1.385		.056		.037	1.395		.050		.093		8660	3430		
KR-137	1.375	1.450		.056		.038	1.461		.050		.098		9070	3690		
KR-143	1.438	1.515		.056		.039	1.526		.050		.103		9490	3960		
KR-145	1.456	1.535		.056		.040	1.546		.050		.108		9610	4120		
KR-150	1.500	1.580		.056		.040	1.591		.050		.108		9900	4240		
KR-156	1.562	1.647	+.005 -.005	.068	+.005 -.000	.043	1.659	+.020 -.000	.062	+.003 -.003	.113	+.005 -.005	12780	4750		
KR-162	1.625	1.715		.068		.045	1.727		.062		.113		13290	5170		
KR-165	1.653	1.745		.068		.046	1.757		.062		.118		13520	5380		
KR-168	1.688	1.780		.068		.046	1.793		.062		.118		13810	5490		
KR-175	1.750	1.845		.068		.048	1.858		.062		.118		14320	5940		
KR-181	1.812	1.910		.068		.049	1.923		.062		.123		14820	6280		
KR-185	1.850	1.949		.068		.050	1.963		.062		.123		15130	6540		
KR-187	1.875	1.975		.068		.050	1.989		.062		.128		15340	6630		
KR-193	1.938	2.040		.068		.051	2.054		.062		.128		15850	6990		
KR-200	2.000	2.110		.068		.055	2.125		.062		.138		16360	7780		
KR-206	2.062	2.175	+.006 -.006	.086	+.005 -.000	.057	2.190	+.025 -.000	.078	+.003 -.003	.141	+.005 -.005	21220	8310		
KR-212	2.125	2.240		.086		.058	2.255		.078		.141		21870	8710		
KR-218	2.188	2.305		.086		.059	2.321		.078		.141		22520	9130		
KR-225	2.250	2.370		.086		.060	2.386		.078		.141		23160	9540		
KR-231	2.312	2.440		.086		.064	2.457		.078		.188		23800	10460		
KR-237	2.375	2.505		.086		.065	2.522		.078		.188		24440	10910		
KR-244	2.440	2.570		.086		.065	2.588		.078		.188		25110	11210		
KR-250	2.500	2.635		.086		.068	2.653		.078		.188		25730	12020		
KR-253	2.531	2.668		.086		.069	2.687		.078		.188		26050	12350		
KR-256	2.562	2.700		.103		.069	2.720		.093		.188		29940	12500		
KR-262	2.625	2.765	.103	.070	2.785	.093	.188	30680	12990							
KR-268	2.688	2.834	.103	.073	2.855	.093	.188	31410	13870							
KR-275	2.750	2.900	.103	.075	2.921	.093	.188	32140	14580							
KR-281	2.813	2.965	.103	.076	2.987	.093	.188	32880	15110							
KR-283	2.834	2.987	.103	.077	3.009	.093	.188	33120	15430							



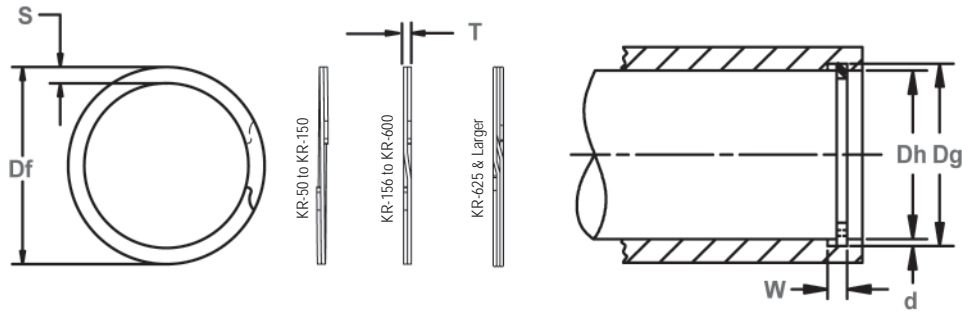

Free Diameter & Ring Measurements

Housing Diameter & Groove Dimensions

RING NO.	HOUSING DIAMETER		GROOVE SIZE				RING SIZE				THRUST LOAD (lbs.)			
	(In.)		DIAMETER		WIDTH		DEPTH		FREE DIAMETER		SECTION		RING Safety factor of 3	GROOVE Safety factor of 2
	Dh	Dg	Tol.	W	Tol.	d	Df	Tol.	T	Tol.	S	Tol.		
KR-287	2.875	3.030		.103		.078	3.053	+ .025	.093		.188		33600	15850
KR-300	3.000	3.165		.103		.083	3.188	- .000	.093		.188		35060	17600
KR-306	3.062	3.230		.120		.084	3.253		.111		.250		42710	18180
KR-312	3.125	3.295		.120		.085	3.318		.111		.250		43590	18780
KR-315	3.156	3.328		.120		.086	3.354		.111		.250		44040	19190
KR-325	3.250	3.426		.120		.088	3.450		.111		.250		45330	20220
KR-334	3.346	3.525		.120		.090	3.550		.111		.250		46670	21290
KR-346	3.464	3.650		.120		.093	3.675		.111		.250		48320	22770
KR-350	3.500	3.690		.120		.095	3.716	+ .030	.111		.250		48820	23500
KR-354	3.543	3.735	+ .006	.120	+ .005	.096	3.761	- .000	.111	+ .003	.250		49420	24040
KR-356	3.562	3.756	- .006	.120	- .000	.097	3.783		.111	- .003	.250		49690	24420
KR-362	3.625	3.822		.120		.099	3.849		.111		.250		50560	25370
KR-375	3.750	3.955		.120		.103	3.982		.111		.250		52310	27300
KR-387	3.875	4.087		.120		.106	4.115		.111		.250		54050	29030
KR-393	3.938	4.150		.120		.106	4.178		.111		.250		54930	29510
KR-400	4.000	4.220		.120		.110	4.248		.111		.250		55800	31100
KR-412	4.125	4.345		.120		.110	4.373		.111		.312		57540	32070
KR-425	4.250	4.470		.120		.110	4.500		.111		.312		59280	33050
KR-433	4.330	4.556		.120		.113	4.586	+ .035	.111		.312		60400	34590
KR-450	4.500	4.735		.120		.118	4.768	- .000	.111		.312		62770	37530
KR-462	4.625	4.865		.120		.120	4.897		.111		.312		64510	39230
KR-475	4.750	4.995		.120		.123	5.028		.111		.312		66260	41300
KR-500	5.000	5.260		.120		.130	5.295		.111		.312		69740	45950
KR-525	5.250	5.520		.139		.135	5.559		.127		.375		83790	50100
KR-537	5.375	5.645	+ .007	.139	+ .006	.135	5.685	+ .045	.127	+ .004	.375		85780	51290
KR-550	5.500	5.770	- .007	.139	- .000	.135	5.810	- .000	.127	- .004	.375		87780	52480
KR-575	5.750	6.020		.139		.135	6.062		.127		.375		91770	54870
KR-600	6.000	6.270		.139		.135	6.314		.127		.375		95760	57260
KR-625	6.250	6.530		.174		.140	6.576		.165		.312		129590	61850
KR-650	6.500	6.790		.174		.145	6.837	+ .055	.165		.312		134780	66620
KR-662	6.625	6.925		.174		.150	6.973	- .000	.165		.312		137370	70240
KR-675	6.750	7.055		.174		.153	7.104		.165		.312		139960	73000
KR-700	7.000	7.315		.174		.158	7.366		.165		.312		145140	78180
KR-725	7.250	7.575		.209		.163	7.628		.189		.375		172190	83530
KR-750	7.500	7.840		.209		.170	7.895		.189		.375		178130	90120
KR-775	7.750	8.100	+ .008	.209	+ .008	.175	8.156		.189	+ .005	.375		184070	95870
KR-800	8.000	8.360	- .008	.209	- .000	.180	8.418		.189	- .005	.375		190000	101790
KR-825	8.250	8.620		.209		.185	8.680		.189		.375		195940	107880
KR-850	8.500	8.880		.209		.190	8.942	+ .070	.189		.375		201880	114160
KR-875	8.750	9.145		.209		.198	9.209	- .000	.189		.375		207820	122460
KR-900	9.000	9.405		.209		.203	9.471		.189		.375		213750	129140
KR-925	9.250	9.669		.209		.210	9.736		.189		.375		219690	137310
KR-950	9.500	9.930		.209		.215	9.999		.189		.375		225630	144380
KR-975	9.750	10.189		.209		.220	10.260		.189		.375		231570	151620
KR-1000	10.000	10.450		.209		.225	10.552		.189		.375		237500	159040
KR-1050	10.500	10.970		.209		.235	11.072		.189		.375		249380	174420

# CR Spiral Shaft Rings

## External, Medium-Heavy Duty

These 2-turn and multi-turn rings provide 360° groove contact and are designed for applications with medium-high thrust loads.

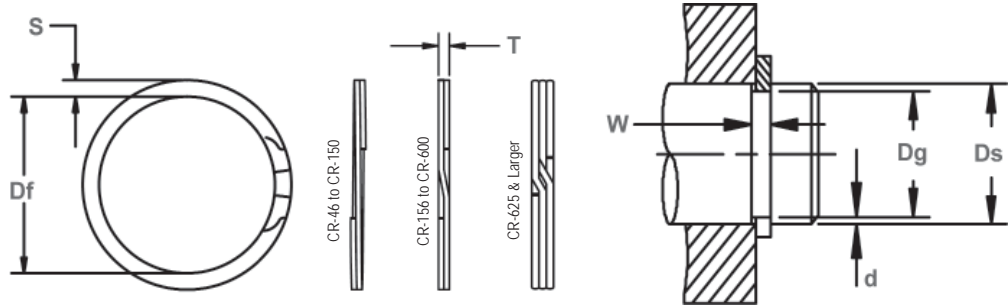

Free Diameter & Ring Measurements

Shaft Diameter & Groove Dimensions

RING NO.	SHAFT DIAMETER (In.)	GROOVE SIZE					FREE DIAMETER			RING SIZE THICKNESS		SECTION		THRUST LOAD (lbs.)		R.P.M. LIMITS Standard Material (Carbon Steel)
		DIAMETER		WIDTH		DEPTH							RING Safety factor of 3	GROOVE Safety factor of 2		
		Dg	Tol.	W	Tol.	d	Df	Tol.	T	Tol.	S	Tol.				
CR-46	.469	.443	+.002	.029		.013	.436		.025		.045		1800	430	28820	
CR-50	.500	.474	-.002	.039		.013	.469		.035		.045		2530	460	20780	
CR-55	.551	.524		.039		.014	.518		.035		.045		2790	550	18130	
CR-56	.562	.535		.039		.014	.529		.035		.045		2840	560	17270	
CR-59	.594	.565		.039		.015	.559		.035		.045		3000	630	15200	
CR-62	.625	.596		.039		.015	.590		.035		.055		3160	660	15700	
CR-66	.669	.638		.039		.016	.630		.035		.055		3380	760	15600	
CR-68	.688	.655	+.003	.046	+.003	.017	.648	+.000	.042		.065		4180	830	15600	
CR-75	.750	.715	-.003	.046	-.000	.018	.708	-.013	.042		.065		4550	950	12750	
CR-78	.781	.745		.046		.018	.738		.042		.065		4740	990	11590	
CR-81	.812	.776		.046		.018	.768		.042	+.002	.065		4930	1030	11300	
CR-87	.875	.835		.046		.020	.827		.042	-.002	.075		5310	1240	10660	
CR-93	.938	.894		.046		.022	.886		.042		.075		5690	1460	9100	
CR-98	.984	.940		.046		.022	.934		.042		.075		5970	1530	6980	
CR-100	1.000	.955		.046		.023	.947		.042		.075		6070	1630	7800	
CR-102	1.023	.977		.046		.023	.969		.042		.075		6210	1660	7400	
CR-106	1.062	1.015		.056		.024	1.005		.050		.088	+.004	7010	1800	8660	
CR-112	1.125	1.075		.056		.025	1.064		.050		.088	-.004	7420	1990	7960	
CR-118	1.188	1.135	+.004	.056		.027	1.126		.050		.088		7370	2270	6320	
CR-125	1.250	1.195	-.004	.056		.028	1.184	+.000	.050		.093		8250	2470	6500	
CR-131	1.312	1.250		.056		.031	1.240	-.015	.050		.098		8660	2880	5800	
CR-137	1.375	1.310		.056		.033	1.298		.050		.103		9070	3210	6000	
CR-143	1.438	1.370		.056		.034	1.359		.050		.103		9490	3460	5160	
CR-150	1.500	1.430		.056	+.004	.035	1.419		.050		.103		9900	3710	4670	
CR-156	1.562	1.490		.068	-.000	.036	1.476		.062		.108		12780	3980	5160	
CR-162	1.625	1.550		.068		.038	1.537		.062		.118		13290	4370	4690	
CR-168	1.687	1.610		.068		.039	1.598		.062		.118		13800	4650	4110	
CR-175	1.750	1.670	+.005	.068		.040	1.657	+.000	.062		.118		14320	4950	3930	
CR-177	1.771	1.689	-.005	.068		.041	1.676	-.020	.062		.123		14490	5130	3960	
CR-181	1.812	1.730		.068		.041	1.714		.062		.123		14820	5250	4170	
CR-187	1.875	1.790		.068		.043	1.774		.062		.123		15340	5700	3850	
CR-196	1.969	1.879		.068		.045	1.864		.062		.123		16110	6260	3320	
CR-200	2.000	1.910		.068		.045	1.894		.062	+.003	.128		16360	6360	3410	
CR-206	2.062	1.970		.086		.046	1.955		.078	-.003	.141		21220	6710	3340	
CR-212	2.125	2.027		.086		.049	2.012		.078		.141		21870	7360	3120	
CR-215	2.156	2.057		.086		.050	2.041		.078		.141		22190	7620	3120	
CR-225	2.250	2.145		.086		.053	2.129		.078		.141		23160	8430	2820	
CR-231	2.312	2.205	+.006	.086	+.005	.054	2.188	+.000	.078		.141		23800	8830	2730	
CR-237	2.375	2.265	-.006	.086	-.000	.055	2.248	-.025	.078		.141		24440	9230	2560	
CR-243	2.437	2.325		.086		.056	2.307		.078		.141		25080	9650	2480	
CR-250	2.500	2.385		.086		.058	2.366		.078		.188		25730	10250	3040	
CR-255	2.559	2.443		.086		.058	2.424		.078		.188	+.005	26340	10490	3430	
CR-262	2.625	2.505		.086		.060	2.485		.078		.188	-.005	27020	11130	2780	
CR-268	2.687	2.565		.086		.061	2.545		.078		.188		27660	11590	2630	

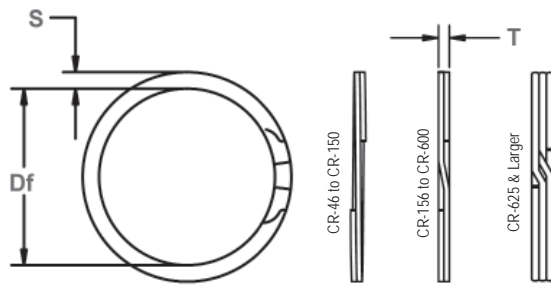

Free Diameter & Ring Measurements

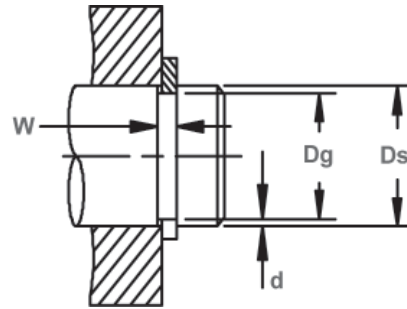

Shaft Diameter & Groove Dimensions

RING NO.	SHAFT DIAMETER (In.)	GROOVE SIZE					RING SIZE				SECTION		THRUST LOAD (lbs.)		R.P.M. LIMITS Standard Material (Carbon Steel)	
		DIAMETER		WIDTH		DEPTH	FREE DIAMETER			THICKNESS				RING Safety factor of 3		GROOVE Safety factor of 2
		Ds	Dg	Tol.	W	Tol.	d	Df	Tol.	T	Tol.	S	Tol.			
CR-275	2.750	2.625		.103		.063	2.604		.093		.188		32140	12250	2560	
CR-287	2.875	2.742		.103		.067	2.722		.093		.188		33600	13620	2260	
CR-293	2.937	2.801		.103		.068	2.780		.093		.188		34320	14120	2200	
CR-300	3.000	2.860		.103		.070	2.838		.093		.188		35060	14840	2150	
CR-306	3.062	2.920		.103		.071	2.897	+ .000	.093		.188		35790	15370	2090	
CR-312	3.125	2.980		.103		.073	2.957	- .030	.093		.188		36520	16130	1990	
CR-315	3.156	3.010		.103		.073	2.986		.093		.188		36880	16290	1990	
CR-325	3.250	3.100		.103		.075	3.075		.093		.188		37980	17230	1900	
CR-334	3.344	3.190		.103		.077	3.164		.093		.188		39080	18200	1810	
CR-343	3.437	3.280	+ .006	.103	+ .005	.079	3.254		.093	+ .003	.188	+ .005	40170	19190	1690	
CR-350	3.500	3.340	- .006	.120	- .000	.080	3.315		.111	- .003	.250	- .005	48820	19790	2020	
CR-354	3.543	3.381		.120		.081	3.356		.111		.250		49420	20290	1960	
CR-362	3.625	3.458		.120		.084	3.433		.111		.250		50560	21520	1860	
CR-368	3.687	3.517		.120		.085	3.490		.111		.250		51430	22150	1860	
CR-375	3.750	3.577		.120		.087	3.550		.111		.250		52310	23060	1790	
CR-387	3.875	3.696		.120		.090	3.670	+ .000	.111		.250		54050	24650	1620	
CR-393	3.938	3.756		.120		.091	3.730	- .040	.111		.250		54930	25330	1560	
CR-400	4.000	3.815		.120		.093	3.787		.111		.250		55800	26300	1560	
CR-425	4.250	4.065		.120		.093	4.032		.111		.250		59280	27940	1350	
CR-437	4.375	4.190		.120		.093	4.162		.111		.250		61030	28760	1250	
CR-450	4.500	4.310		.120		.095	4.280		.111		.250		62770	30220	1210	
CR-475	4.750	4.550		.120		.100	4.515		.111		.250		66260	33580	1160	
CR-500	5.000	4.790		.120		.105	4.755		.111		.250		69740	37110	1020	
CR-525	5.250	5.030		.139		.110	4.995		.127		.375		83790	40820	1280	
CR-550	5.500	5.265	+ .007	.139	+ .006	.118	5.229	+ .000	.127	+ .004	.375		87780	45880	1170	
CR-575	5.750	5.505	- .007	.139	- .000	.123	5.466	- .050	.127	- .004	.375		91770	49990	1100	
CR-600	6.000	5.745		.139		.128	5.705		.127		.375		95760	54290		
CR-625	6.250	5.985		.174		.133	5.942		.165		.312		129590	58760		
CR-650	6.500	6.225		.174		.138	6.182	+ .000	.165		.312		134780	63410		
CR-675	6.750	6.465		.174		.143	6.420	- .060	.165		.312		139960	68230		
CR-700	7.000	6.705		.174		.148	6.658		.165		.312		145140	73230		
CR-725	7.250	6.942		.174		.154	6.894		.165		.312	+ .006	172190	78290		
CR-750	7.500	7.180		.209		.160	7.130		.189		.375	- .006	178130	84820		
CR-775	7.750	7.420	+ .008	.209	+ .008	.165	7.368		.189	+ .005	.375		184070	90390		
CR-800	8.000	7.660	- .008	.209	- .000	.170	7.607		.189	- .005	.375		190000	96130		
CR-825	8.250	7.900		.209		.175	7.845	+ .000	.189		.375		195940	102050		
CR-850	8.500	8.140		.209		.180	8.083	- .070	.189		.375		201880	108150		
CR-875	8.750	8.383		.209		.184	8.321		.189		.375		207820	113800		
CR-900	9.000	8.620		.209		.190	8.560		.189		.375		213750	120870		
CR-925	9.250	8.860		.209		.195	8.798		.189		.375		219690	127500		
CR-950	9.500	9.100		.209		.200	9.036		.189		.375		225630	134300		
CR-975	9.750	9.338		.209		.206	9.273		.189		.375		231570	141970		
CR-1000	10.000	9.575		.209		.213	9.508		.189		.375		237500	150560		

CONTACT FACTORY REGARDING MAX RPM LIMITS FOR LARGER DIAMETER RINGS



# KG Spiral Housing Rings

**Internal, Heavy Duty**  
 These 2-turn rings provide 360° groove contact  
 and are ideal for applications  
 with high thrust loads.

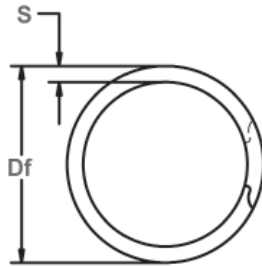

Free Diameter & Ring Measurements

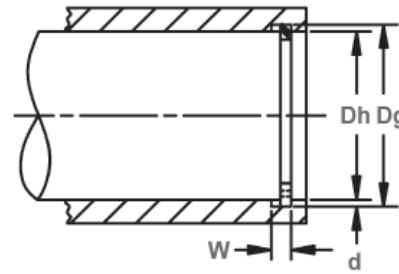

Housing Diameter & Groove Dimensions

RING NO.	HOUSING DIAMETER		GROOVE SIZE				FREE DIAMETER			RING SIZE THICKNESS		SECTION		THRUST LOAD (lbs.)	
	(In.)		DIAMETER		WIDTH		DEPTH		DIAMETER		SECTION		RING Safety factor of 3	GROOVE Safety factor of 2	
	Dh	Dg	Tol.	W	Tol.	d	Df	Tol.	T	Tol.	S	Tol.			
KG-25*	.250	.268		.020		.009	.270		.015		.020		561	159	
KG-31*	.312	.330		.020		.009	.333	+.010	.015		.025		700	198	
KG-37*	.375	.397		.029		.011	.400	-.000	.025		.030		1442	292	
KG-43	.437	.461		.029		.012	.464	+.012/-.000	.025		.035		1680	371	
KG-50	.500	.530	+.002	.039		.015	.538		.035		.045		2530	530	
KG-51	.512	.542	-.002	.039		.015	.550		.035		.045		2590	540	
KG-56	.562	.596		.039		.017	.605		.035		.055		2840	680	
KG-62	.625	.665		.039	+.003	.020	.675		.035		.055		3160	880	
KG-68	.688	.732		.039	-.000	.022	.743		.035		.065		3480	1070	
KG-75	.750	.796		.039		.023	.807		.035		.065		3790	1220	
KG-77	.777	.825		.046		.024	.836		.042		.075		4720	1320	
KG-81	.812	.862		.046		.025	.873		.042		.075		4930	1440	
KG-86	.866	.920		.046		.027	.931		.042	+.002	.075		5260	1650	
KG-87	.875	.931	+.003	.046		.028	.943	+.013	.042	-.002	.085		5310	1730	
KG-90	.901	.959	-.003	.046		.029	.972	-.000	.042		.085		5470	1850	
KG-93	.938	1.000		.046		.031	1.013		.042		.085	+.003	5690	2060	
KG-100	1.000	1.066		.046		.033	1.080		.042		.085	-.005	6070	2330	
KG-102	1.023	1.091		.046		.034	1.105		.042		.085		6210	2460	
KG-106	1.062	1.130		.056		.034	1.138		.050		.103		7010	2550	
KG-112	1.125	1.197		.056		.036	1.205		.050		.103		7420	2860	
KG-118	1.188	1.262		.056		.037	1.271		.050		.103		7840	3110	
KG-125	1.250	1.330	+.004	.056		.040	1.339		.050		.103		8250	3530	
KG-131	1.312	1.396	-.004	.056		.042	1.406		.050		.118		8660	3900	
KG-137	1.375	1.461		.056	+.004	.043	1.471		.050		.118		9070	4180	
KG-143	1.439	1.528		.056	-.000	.045	1.539		.050		.118		9490	4580	
KG-145	1.456	1.548		.056		.046	1.559		.050		.118		9610	4730	
KG-150	1.500	1.594		.056		.047	1.605		.050		.118		9900	4980	
KG-156	1.562	1.658		.068		.048	1.675		.062		.128		12780	5300	
KG-162	1.625	1.725	+.005	.068		.050	1.742	+.020	.062	+.003	.128		13290	5740	
KG-165	1.653	1.755	-.005	.068		.051	1.772	-.000	.062	-.003	.128		13520	5960	
KG-168	1.688	1.792		.068		.052	1.810		.062		.128		13810	6210	
KG-175	1.750	1.858		.068		.054	1.876		.062		.128		14320	6680	

\* No Removal Notch.

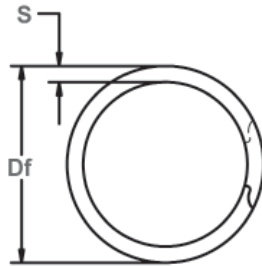

Free Diameter & Ring Measurements

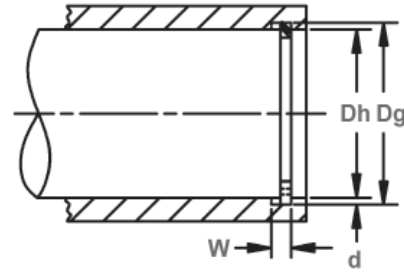
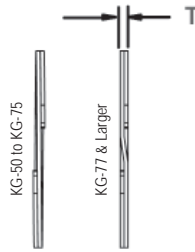

Housing Diameter & Groove Dimensions

RING NO.	HOUSING DIAMETER		GROOVE SIZE				FREE DIAMETER		RING SIZE		SECTION		THRUST LOAD (lbs.)	
			DIAMETER		WIDTH				DEPTH	THICKNESS			RING Safety factor of 3	GROOVE Safety factor of 2
	(In.)	Dh	Dg	Tol.	W	Tol.	d	Df	Tol.	T	Tol.	S	Tol.	
KG-181	1.812	1.922		.068		.055	1.940		.062		.128		14820	7050
KG-185	1.850	1.962	+.005	.068	+.004	.056	1.981	+.020	.062		.158	+.003	15130	7320
KG-187	1.875	1.989	-.005	.068	-.000	.057	2.008	-.000	.062		.158	-.005	15340	7560
KG-193	1.938	2.056		.068		.059	2.075		.062		.158		15850	8080
KG-200	2.000	2.122		.068		.061	2.142		.062		.158		16360	8620
KG-206	2.062	2.186		.086		.062	2.201		.078		.168		21220	9040
KG-212	2.125	2.251		.086		.063	2.267		.078		.168		21870	9460
KG-218	2.188	2.318		.086		.065	2.334		.078		.168		22520	10050
KG-225	2.250	2.382		.086		.066	2.399		.078		.168		23160	10500
KG-231	2.312	2.450		.086		.069	2.467	+.025	.078		.200		23800	11280
KG-237	2.375	2.517		.086		.071	2.535	-.000	.078		.200		24440	11920
KG-244	2.440	2.584		.086		.072	2.602		.078	+.003	.200		25110	12420
KG-250	2.500	2.648		.086		.074	2.667		.078	-.003	.200		25730	13080
KG-253	2.531	2.681		.086		.075	2.700		.078		.200		26050	13420
KG-256	2.562	2.714	+.006	.103	+.005	.076	2.733		.093		.225		29940	13760
KG-262	2.625	2.781	-.006	.103	-.000	.078	2.801		.093		.225		30680	14470
KG-268	2.688	2.848		.103		.080	2.868		.093		.225	+.004	31410	15200
KG-275	2.750	2.914		.103		.082	2.934	+.030	.093		.225	-.006	32140	15940
KG-281	2.813	2.980		.103		.084	3.001	-.000	.093		.225		32880	16700
KG-283	2.834	3.006		.103		.086	3.027		.093		.225		33120	17230
KG-287	2.875	3.051		.103		.088	3.072		.093		.225		33600	17880
KG-300	3.000	3.182		.103		.091	3.204		.093		.225		35060	18300
KG-306	3.062	3.248		.120		.093	3.271		.111		.281		42710	20130
KG-312	3.125	3.315		.120		.095	3.338		.111		.281		43590	20990
KG-315	3.157	3.348		.120		.096	3.371	+.035	.111		.281		44040	21420
KG-325	3.250	3.446		.120		.098	3.470	-.000	.111		.281		45330	22510
KG-334	3.346	3.546		.120		.100	3.571		.111		.281		46670	23650
KG-347	3.464	3.675		.120		.105	3.701		.111		.281		48320	25710



# KG Spiral Housing Rings

**Internal, Heavy Duty**  
 These 2-turn rings provide 360° groove contact  
 and are ideal for applications  
 with high thrust loads.

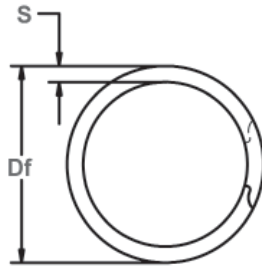

Free Diameter & Ring Measurements

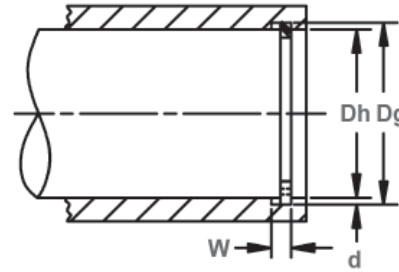

Housing Diameter & Groove Dimensions

RING NO.	HOUSING DIAMETER		GROOVE SIZE				FREE DIAMETER			RING SIZE		SECTION		THURST LOAD (lbs.)	
			DIAMETER		WIDTH					DEPTH	THICKNESS			T	Tol.
	(In.)	Dg	Tol.	W	Tol.	d	Df	Tol.	S	Tol.					
KG-350	3.500	3.710		.120		.105	3.736		.111		.281	+.004 -.006	48820	25980	
KG-354	3.543	3.755		.120		.106	3.781		.111		.281		49420	26550	
KG-356	3.562	3.776		.120		.107	3.802		.111		.281		49690	26940	
KG-362	3.625	3.841		.120		.108	3.868		.111		.281		50560	27670	
KG-375	3.750	3.974		.120		.112	4.002		.111		.312		52310	29690	
KG-387	3.875	4.107		.120		.116	4.136		.111		.312		54050	31770	
KG-393	3.938	4.174		.120		.118	4.203		.111		.312		54930	32850	
KG-400	4.000	4.240		.120		.120	4.270		.111		.312		55800	33930	
KG-412	4.125	4.365		.120		.120	4.369		.111		.312		57540	34990	
KG-425	4.250	4.490		.120		.120	4.501		.111		.312		59280	36050	
KG-433	4.330	4.570		.120		.120	4.588		.111		.312	60400	36730		
KG-450	4.500	4.740		.120		.120	4.770		.111		.312	62770	38170		
KG-462	4.625	4.865		.120		.120	4.899		.111		.312	64510	39230		
KG-475	4.750	4.995		.120		.123	5.030		.111		.312	66260	41300		
KG-500	5.000	5.260		.120		.130	5.297		.111		.312	69740	45950		
KG-525	5.250	5.520		.139		.135	5.559		.127		.350	+.004 -.008	83790	50100	
KG-537	5.375	5.645		.139		.135	5.690		.127		.350		85780	51290	
KG-550	5.500	5.770		.139		.135	5.810		.127		.350		87780	52480	
KG-575	5.750	6.020		.139		.135	6.062		.127		.350		91770	54870	
KG-600	6.000	6.270		.139		.135	6.314		.127		.350		95760	57260	
KG-625	6.250	6.530		.174		.140	6.576		.156		.380		122520	61850	
KG-650	6.500	6.790		.174		.145	6.838		.156		.380		127420	66620	
KG-662	6.625	6.925		.174		.150	6.974		.156		.380		129870	70240	
KG-675	6.750	7.055		.174		.153	7.105		.156		.380		132320	73000	
KG-700	7.000	7.315		.174		.158	7.366		.156		.380		137230	78180	
KG-725	7.250	7.575		.209		.163	7.628		.187		.418	170370	83530		
KG-750	7.500	7.840		.209		.170	7.895		.187		.418	176240	90120		
KG-775	7.750	8.100		.209		.175	8.157		.187		.418	182120	95870		



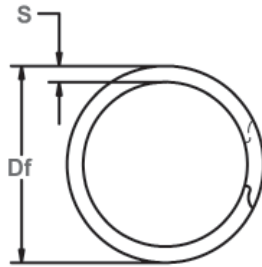

Free Diameter & Ring Measurements

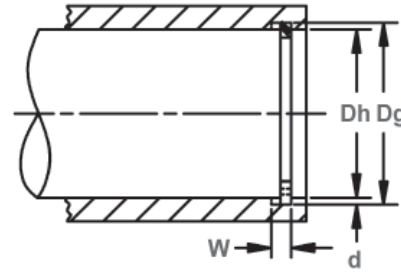
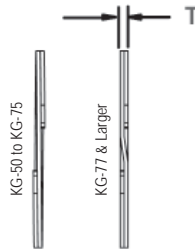

Housing Diameter & Groove Dimensions

RING NO.	HOUSING DIAMETER		GROOVE SIZE				FREE DIAMETER			RING SIZE THICKNESS		SECTION		THRUST LOAD (lbs.)	
			DIAMETER		WIDTH									DEPTH	RING Safety factor of 3
	(In.)														
KG-800	8.000	8.360		.209		.180	8.419		.187		.418		187990	101790	
KG-825	8.250	8.620		.209		.185	8.680		.187		.437		193870	107880	
KG-850	8.500	8.880		.209		.190	8.942		.187		.437		199740	114160	
KG-875	8.750	9.145	+.008	.209		.198	9.209	+.070	.187		.437	+.004	-0.008	205620	122460
KG-900	9.000	9.405													
KG-925	9.250	9.669		.209		.210	9.737		.187		.437		217370	137310	
KG-950	9.500	9.930		.209		.215	10.000		.187		.500		223240	144380	
KG-975	9.750	10.189		.209		.220	10.260		.187		.500		229120	150620	
KG-1000	10.000	10.450		.209		.225	10.523		.187		.500		234990	159040	
KG-1025	10.250	10.711		.209		.235	10.786		.187		.500		246740	174420	
KG-1050	10.500	10.970		.209		.231	11.047		.187		.500		240870	167370	
KG-1075	10.750	11.234		.209	+.008	.242	11.313		.187	+.005	.500		252620	183890	
KG-1100	11.000	11.495		.209		.248	11.575		.187		.500	258490	192830		
KG-1125	11.250	11.756	+.010	.209	-.010	.253	11.838		.187	-.005	.500		264370	201190	
KG-1150	11.500	12.018				.209	.259	12.102	.187		.562	270240	210540		
KG-1175	11.750	12.279		.209		.265	12.365	+.120	.187		.562	+.005	-0.015	276120	220100
KG-1200	12.000	12.540		.209	.270	12.628	.187		.562		281990			229020	
KG-1225	12.250	12.801		.209		.276	12.891		.187		.562		287860	238990	
KG-1250	12.500	13.063		.209		.282	13.154		.187		.562		293740	249170	
KG-1275	12.750	13.324		.209		.287	13.417		.187		.562		299610	258660	
KG-1300	13.000	13.585		.209		.293	13.680		.187		.662		305490	269240	
KG-1325	13.250	13.846		.209		.298	13.943		.187		.662		311360	279100	
KG-1350	13.500	14.108		.209		.304	14.207		.187		.662		317240	290100	
KG-1375	13.750	14.369	+.012	.209	-.012	.310	14.470	+.140	.187		.662			323110	301300
KG-1400	14.000	14.630				.315	14.732		.187		.662			328990	311730
KG-1425	14.250	14.891		.209		.321	14.995		.187		.662		334860	323340	
KG-1450	14.500	15.153		.209		.327	15.259		.187		.750		340740	335160	
KG-1475	14.750	15.414		.209		.332	15.522		.187		.750		346610	346150	
KG-1500	15.000	15.675		.209		.338	15.785		.187		.750		352490	358380	

# CG Spiral Shaft Rings

**External, Heavy Duty**  
 These 2-turn rings provide 360° groove contact and are ideal for applications with high thrust loads.

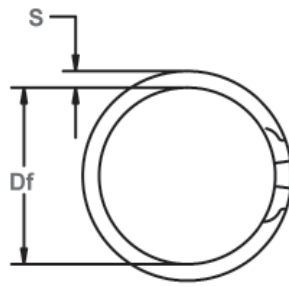

Free Diameter & Ring Measurements

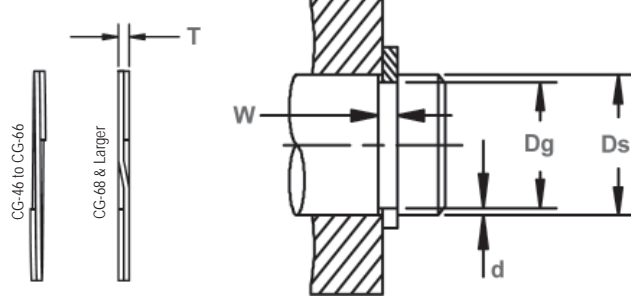

Shaft Diameter & Groove Dimensions

RING NO.	SHAFT DIAMETER (In.)	GROOVE SIZE					RING SIZE					THRUST LOAD (lbs.)		R.P.M. LIMITS Standard Material (Carbon Steel)	
		DIAMETER		WIDTH		DEPTH	FREE DIAMETER		THICKNESS		SECTION		RING Safety factor of 3		GROOVE Safety factor of 2
		Dg	Tol.	W	Tol.	d	Df	Tol.	T	Tol.	S	Tol.			
CG-25*	.250	.230		.029		.010	.228		.021		.020		961	177	36651
CG-31*	.312	.290		.029		.011	.287	+ .000	.025		.025		1200	243	31364
CG-37*	.375	.352		.029		.012	.349	- .010	.025		.030		1442	305	23025
CG-43	.437	.412	+ .002	.029		.013	.409	+ .000/- .012	.025		.035		1680	386	18019
CG-46	.469	.443	- .002	.029		.013	.439		.025		.045		1880	430	21450
CG-50	.500	.468		.039		.016	.464		.035		.050		2530	570	20600
CG-55	.551	.519		.039		.016	.514		.035		.050		2790	620	18260
CG-56	.562	.530		.039		.016	.525		.035		.050		2840	640	17400
CG-59	.594	.559		.039	+ .003	.018	.554		.035		.050		3000	760	15390
CG-62	.625	.588	- .000	.039		.019	.583		.035		.055		3160	840	14730
CG-66	.669	.629		.039		.020	.623		.035		.055		3380	950	13860
CG-68	.688	.646		.046		.021	.641		.042		.065		4180	1020	13510
CG-75	.750	.704	+ .003	.046		.023	.698		.042		.065		4550	1220	12190
CG-78	.781	.733	- .003	.046		.024	.727		.042	+ .002	.065		4740	1330	11110
CG-81	.812	.762		.046		.025	.756	+ .000	.042	- .002	.065	+ .003	4930	1440	10150
CG-87	.875	.821		.046		.027	.814	- .013	.042		.075	- .005	5310	1670	10340
CG-93	.938	.882		.046		.028	.875		.042		.075		5690	1860	8760
CG-98	.984	.926		.046		.029	.919		.042		.085		5970	2020	8640
CG-100	1.000	.940		.046		.030	.932		.042		.085		6070	2120	8940
CG-102	1.023	.961		.046		.031	.953		.042		.085		6210	2240	8500
CG-106	1.062	.998		.056		.032	.986		.050		.103		7010	2400	11260
CG-112	1.125	1.059		.056		.033	1.047		.050		.103		7420	2620	9820
CG-118	1.188	1.118		.056		.035	1.105		.050		.103		7840	2940	9040
CG-125	1.250	1.176	+ .004	.056		.037	1.163		.050		.103		8250	3270	8042
CG-131	1.312	1.232	- .004	.056	+ .004	.040	1.218		.050		.118		8660	3710	8280
CG-137	1.375	1.291		.056	- .000	.042	1.277		.050		.118		9070	4080	7430
CG-143	1.438	1.350		.056		.044	1.336		.050		.118		9490	4470	6700
CG-150	1.500	1.406		.056		.047	1.385		.050		.118		9900	4980	6540
CG-156	1.562	1.468	+ .005	.068		.047	1.453	+ .000	.062	+ .003	.128		12780	5190	6110
CG-162	1.625	1.529	- .005	.068		.048	1.513	- .020	.062	- .003	.128		13290	5510	5750

\* No Removal Notch.

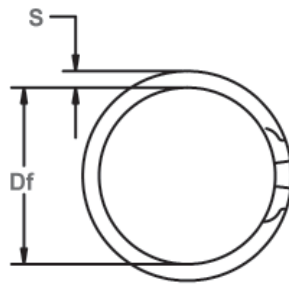

Free Diameter & Ring Measurements

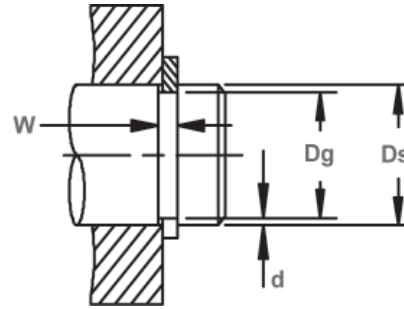
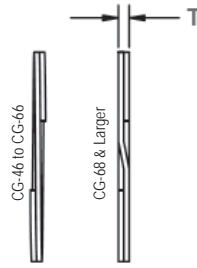

Shaft Diameter & Groove Dimensions

RING NO.	SHAFT DIAMETER		GROOVE SIZE				FREE DIAMETER			RING SIZE THICKNESS		SECTION		THRUST LOAD (lbs.)		R.P.M. LIMITS Standard Material (Carbon Steel)
	Ds	Dg	DIAMETER		DEPTH	DIAMETER		T	Tol.	S	Tol.	RING Safety factor of 3	GROOVE Safety factor of 2			
			W	Tol.		Df	Tol.									
CG-168	1.687	1.589		.068		.049	1.573		.062		.128	13800	5840	5260		
CG-175	1.750	1.650		.068		.050	1.633		.062		.128	14320	6190	4970		
CG-177	1.771	1.669	+ .005	.068	+ .004	.051	1.651	+ .000	.062		.128	14490	6380	4990		
CG-181	1.812	1.708	- .005	.068	- .000	.052	1.690	- .020	.062		.128	14820	6660	4720		
CG-187	1.875	1.769		.068		.053	1.751		.062		.158	15340	7020	4540		
CG-196	1.969	1.857		.068		.056	1.838		.062		.158	16110	7790	4730		
CG-200	2.000	1.886		.068		.057	1.867		.062		.158	16360	8060	4560		
CG-206	2.062	1.946		.086		.058	1.932		.078		.168	21220	8450	3810		
CG-212	2.125	2.003		.086		.061	1.989		.078		.168	21870	9160	3560		
CG-215	2.156	2.032		.086		.062	2.018		.078		.168	22190	9450	3450		
CG-225	2.250	2.120		.086		.065	2.105		.078		.168	23160	10340	3240		
CG-231	2.312	2.178		.086		.067	2.163	+ .000	.078	+ .003	.168	23800	10950	3040		
CG-237	2.375	2.239		.086		.068	2.223	- .025	.078	- .003	.200	24440	11420	3380		
CG-243	2.437	2.299		.086		.069	2.283		.078		.200	25080	11890	3180		
CG-250	2.500	2.360		.086		.070	2.343		.078		.200	25730	12370	3090		
CG-255	2.559	2.419		.086		.070	2.402		.078		.200	26340	12660	2920		
CG-262	2.625	2.481	+ .006	.086	+ .005	.072	2.464		.078		.200	27020	13360	2750		
CG-268	2.687	2.541	- .006	.086	- .000	.073	2.523		.078		.200	27660	13870	2680		
CG-275	2.750	2.602		.103		.074	2.584		.093		.225	32140	14390	2790		
CG-287	2.875	2.721		.103		.077	2.702		.093		.225	33600	15650	2590		
CG-293	2.937	2.779		.103		.079	2.760		.093		.225	34320	16400	2460		
CG-300	3.000	2.838		.103		.081	2.818		.093		.225	35060	17180	2410		
CG-306	3.062	2.898		.103		.082	2.878	+ .000	.093		.225	35790	17750	2290		
CG-312	3.125	2.957		.103		.084	2.936	- .030	.093		.225	36520	18560	2240		
CG-315	3.156	2.986		.103		.085	2.965		.093		.225	36880	18960	2190		
CG-325	3.250	3.076		.103		.087	3.054		.093		.225	37980	19990	2100		
CG-334	3.344	3.166		.103		.089	3.144		.093		.225	39080	21040	1960		
CG-343	3.437	3.257		.103		.090	3.234		.093		.225	40170	21870	1880		

# CG Spiral Shaft Rings

**External, Heavy Duty**  
 These 2-turn rings provide 360° groove contact and are ideal for applications with high thrust loads.

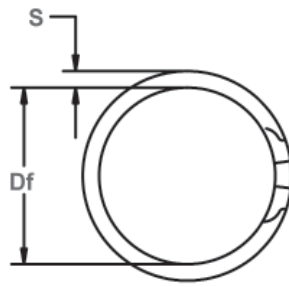

Free Diameter & Ring Measurements

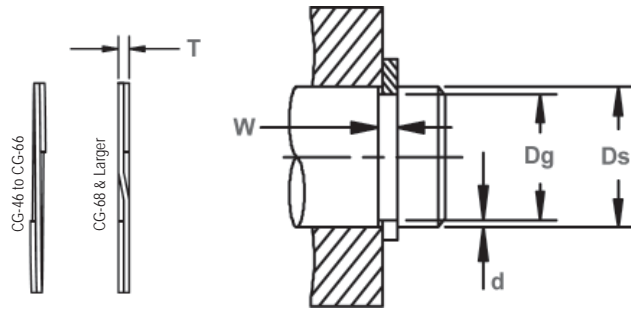

Shaft Diameter & Groove Dimensions

RING NO.	SHAFT DIAMETER (In.)	GROOVE SIZE					RING SIZE				SECTION		THRUST LOAD (lbs.)		R.P.M. LIMITS Standard Material (Carbon Steel)
		DIAMETER		WIDTH		DEPTH	FREE DIAMETER		THICKNESS		S	Tol.	RING Safety factor of 3	GROOVE Safety factor of 2	
		Ds	Dg	Tol.	W	Tol.	d	Df	Tol.	T					
CG-350	3.500	3.316		.120		.092	3.293		.111		.270		48820	22760	2090
CG-354	3.543	3.357		.120		.093	3.333		.111		.270		49420	23290	2080
CG-362	3.625	3.435		.120		.095	3.411		.111		.270		50560	24340	1970
CG-368	3.687	3.493		.120		.097	3.469		.111		.270		51430	25280	1890
CG-375	3.750	3.552	+ .006	.120	+ .005	.099	3.527	+ .000	.111	+ .003	.270	+ .004	52310	26240	1860
CG-387	3.875	3.673	- .006	.120	- .000	.101	3.647	- .035	.111	- .003	.270	- .006	54050	27670	1750
CG-393	3.938	3.734		.120		.102	3.708		.111		.270		54930	28390	1690
CG-400	4.000	3.792		.120		.104	3.765		.111		.270		55800	29410	1660
CG-425	4.250	4.065		.120		.093	4.037		.111		.270		59280	27940	1440
CG-437	4.375	4.190		.120		.093	4.161		.111		.270		61030	28760	1360
CG-450	4.500	4.310		.120		.095	4.280		.111		.270		62770	30220	1300
CG-475	4.750	4.550		.120		.100	4.518		.111		.270		66260	36930	1180
CG-500	5.000	4.790		.120		.105	4.756		.111		.270		69740	37110	1080
CG-525	5.250	5.030		.139		.110	4.995		.127		.350		83790	40820	1210
CG-550	5.500	5.265	+ .007	.139	+ .006	.118	5.228	+ .000	.127	+ .004	.350		87780	45880	1120
CG-575	5.750	5.505	- .007	.139	- .000	.123	5.466	- .050	.127	- .004	.350		91770	49990	1030
CG-600	6.000	5.745		.139		.128	5.705		.127		.350		95760	54290	
CG-625	6.250	5.985		.174		.133	5.938		.156		.418		122520	58760	
CG-650	6.500	6.225		.174		.138	6.181	+ .000	.156		.418		127420	63410	
CG-675	6.750	6.465		.174		.143	6.410	- .060	.156		.418	+ .004	132330	68230	
CG-700	7.000	6.705		.174		.148	6.648		.156		.418	- .008	137230	73230	
CG-725	7.250	6.942	+ .008	.174	+ .008	.154	6.891		.156	+ .005	.418		142130	78920	
CG-750	7.500	7.180	- .008	.209	- .000	.160	7.130		.187	- .005	.437		176240	84820	
CG-775	7.750	7.420		.209		.165	7.368	+ .000	.187		.437		182120	90390	
CG-800	8.000	7.660		.209		.170	7.606	- .070	.187		.437		187990	96130	
CG-825	8.250	7.900		.209		.175	7.845		.187		.437		193870	102050	
CG-850	8.500	8.140		.209		.180	8.083		.187		.437		199740	108150	

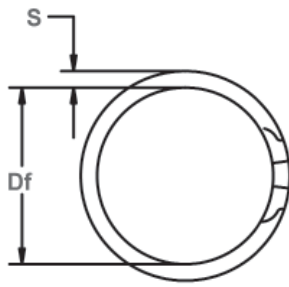

Free Diameter & Ring Measurements

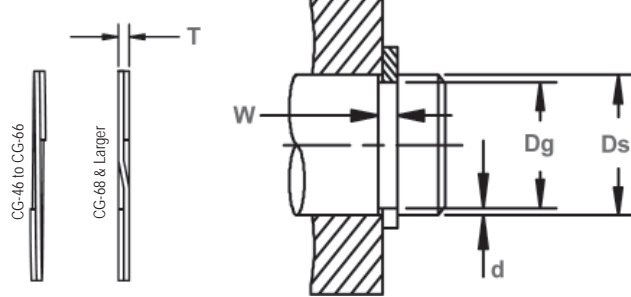

Shaft Diameter & Groove Dimensions

RING NO.	SHAFT DIAMETER (In.)	GROOVE SIZE					RING SIZE				SECTION		THRUST LOAD (lbs.)		R.P.M. LIMITS Standard Material (Carbon Steel)
		DIAMETER		WIDTH		DEPTH	FREE DIAMETER		THICKNESS		S	Tol.	RING Safety factor of 3	GROOVE Safety factor of 2	
		Dg	Tol.	W	Tol.	d	Df	Tol.	T	Tol.					
CG-875	8.750	8.383		.209		.184	8.324		.187		.437	+0.04 -0.006	205620	113800	CONTACT FACTORY LIMITS REGARDING MAX RPM LARGER DIAMETER RINGS
CG-900	9.000	8.620		.209		.190	8.560		.187		.500		211490	120870	
CG-925	9.250	8.860	+ .008	.209		.195	8.798	+ .000	.187		.500		217370	127500	
CG-950	9.500	9.100	- .008	.209		.200	9.036	- .070	.187		.500		223240	134300	
CG-975	9.750	9.338		.209		.206	9.275		.187		.500		229120	141970	
CG-1000	10.000	9.575		.209		.213	9.508		.187		.500		234990	150560	
CG-1025	10.250	9.814		.209		.218	9.745		.187		.500		240870	157950	
CG-1050	10.500	10.054		.209		.223	9.984		.187		.500		246740	165510	
CG-1075	10.750	10.293		.209		.229	10.221		.187		.500		252620	174010	
CG-1100	11.000	10.533		.209		.234	10.459		.187		.500		258490	181950	
CG-1125	11.250	10.772	+ .010	.209	+ .008	.239	10.692	+ .000	.187	+ .005	.500		264360	190060	
CG-1150	11.500	11.011	- .010	.209	- .000	.245	10.934	- .090	.187	- .005	.562		270240	199160	
CG-1175	11.750	11.250		.209		.250	11.171		.187		.562	+ .005	276120	207640	
CG-1200	12.000	11.490		.209		.255	11.410		.187		.562	- .010	281990	216300	
CG-1225	12.250	11.729		.209		.261	11.647		.187		.562		287860	226000	
CG-1250	12.500	11.969		.209		.266	11.885		.187		.562		293740	235030	
CG-1275	12.750	12.208		.209		.271	12.124		.187		.562		299610	244240	
CG-1300	13.000	12.448		.209		.276	12.361		.187		.662		305490	253620	
CG-1325	13.250	12.687		.209		.282	12.598		.187		.662		311360	264120	
CG-1350	13.500	12.927		.209		.287	12.837		.187		.662		317240	273870	
CG-1375	13.750	13.166		.209		.292	13.074	+ .000	.187		.662		323110	283800	
CG-1400	14.000	13.405	+ .012	.209		.298	13.311	- .110	.187		.662		328990	294900	
CG-1425	14.250	13.644	- .012	.209		.303	13.548		.187		.662		334860	305200	
CG-1450	14.500	13.884		.209		.308	13.787		.187		.750		340740	315680	
CG-1475	14.750	14.123		.209		.314	14.024		.187		.750		346610	327380	
CG-1500	15.000	14.363		.209		.319	14.262		.187		.750		352490	338230	

# KLR Spiral Housing Rings

## Internal, Heavy-Duty Snap Ring

These single-turn snap rings are ideal for applications involving high thrust loads.

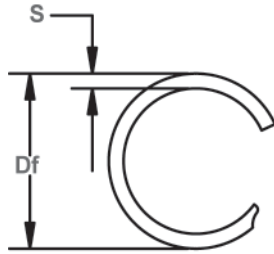

Free Diameter & Ring Measurements

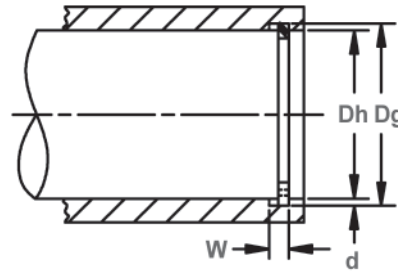
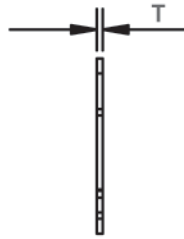

Housing Diameter & Groove Dimensions

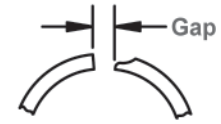

End Design

RING NO.	HOUSING DIAMETER (In.)	GROOVE SIZE				RING SIZE						THRUST LOAD (lbs.)	
		DIAMETER		WIDTH		FREE DIAMETER		THICKNESS		SECTION		RING Safety factor of 3	GROOVE Safety factor of 2
		Dh	Dg Tol.	W Tol.	Df Tol.	T Tol.	S Tol.						
KLR-50	.500	.524		.043	.529		.037		.055		2325	424	
KLR-56	.562	.586	+.004	.043	.591		.037		.055		2613	477	
KLR-62	.625	.657	-.000	.043	.665	+.013	.037		.065		2906	707	
KLR-68	.687	.719		.043	.726	-.000	.037		.065		3194	777	
KLR-75	.750	.790	+.005	.043	.797		.037		.075		3487	1060	
KLR-81	.812	.852	-.000	.043	.860		.037		.075		3775	1148	
KLR-87	.875	.915		.043	.924		.037		.075		4068	1237	
KLR-93	.937	.985		.051	1.000		.045		.085		5334	1590	
KLR-100	1.000	1.048	+.008	.051	1.058		.045		.085		5693	1696	
KLR-106	1.062	1.110	-.000	.051	1.121		.045		.094		6045	1802	
KLR-112	1.125	1.181		.051	1.192		.045	±.002	.094	±.004	6404	2227	
KLR-118	1.187	1.243		.051	1.252	+.015	.045		.094		6757	2349	
KLR-125	1.250	1.316		.051	1.336	-.000	.045		.094		7116	2916	
KLR-131	1.312	1.378		.051	1.391		.045		.094		7469	3060	
KLR-137	1.375	1.453		.063	1.470		.057		.128		9307	3791	
KLR-143	1.437	1.515	+.010	.063	1.529		.057		.128		9727	3961	
KLR-150	1.500	1.578	-.000	.063	1.592		.057		.128		10153	4135	
KLR-156	1.562	1.666		.073	1.687		.067		.158		12400	5741	
KLR-162	1.625	1.729		.073	1.746		.067		.158		12901	5973	
KLR-168	1.687	1.791		.073	1.808	+.020	.067		.158		13393	6201	
KLR-175	1.750	1.862	-.000	.073	1.885	-.000	.067		.158		13893	6927	
KLR-181	1.812	1.924		.073	1.942		.067		.158		14385	7173	
KLR-187	1.875	1.987		.073	2.007		.067		.158		14885	7422	
KLR-193	1.937	2.055		.085	2.074		.076		.200		16649	8078	
KLR-200	2.000	2.118		.085	2.143		.076		.200		17191	8341	
KLR-206	2.062	2.180		.085	2.200		.076		.200		17724	8599	
KLR-212	2.125	2.243		.085	2.264		.076		.200		18265	8862	
KLR-218	2.187	2.305		.085	2.327	+.025	.076		.200		18798	9121	
KLR-225	2.250	2.368		.085	2.389	-.000	.076		.200		19340	9384	
KLR-231	2.312	2.430	+.012	.085	2.453		.076		.200		19873	9642	
KLR-237	2.375	2.493	-.000	.085	2.517		.076		.200		20414	9905	
KLR-243	2.437	2.555		.085	2.582		.076		.200		20947	10163	
KLR-250	2.500	2.618		.085	2.643		.076		.200		21488	10426	
KLR-256	2.562	2.680		.104	2.705		.095		.200		26225	10685	
KLR-262	2.625	2.743		.104	2.777		.095	±.003	.200	±.005	26870	10947	
KLR-268	2.687	2.805		.104	2.828		.095		.200		27504	11206	
KLR-275	2.750	2.868		.104	2.899		.095		.200		28149	11469	
KLR-281	2.812	2.930		.104	2.958	+.030	.095		.200		28784	11727	
KLR-287	2.875	2.993		.104	3.022	-.000	.095		.200		29429	11990	
KLR-293	2.937	3.055		.104	3.084		.095		.200		30063	12249	
KLR-300	3.000	3.118		.104	3.145		.095		.200		30708	12511	
KLR-306	3.062	3.184		.104	3.218		.095		.200		31343	13203	
KLR-312	3.125	3.263	+.013	.104	3.294		.095		.237		31988	15242	
KLR-318	3.187	3.325	-.000	.104	3.357		.095		.237		32622	15544	
KLR-325	3.250	3.388		.104	3.420		.095		.237		33267	15851	

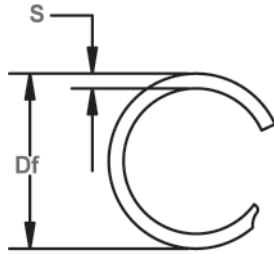

Free Diameter & Ring Measurements

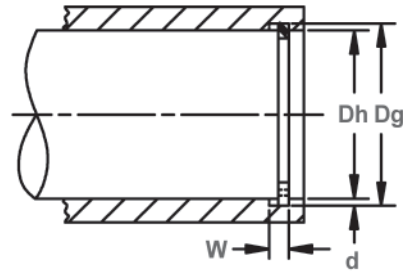
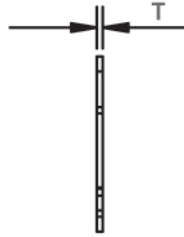

Housing Diameter & Groove Dimensions

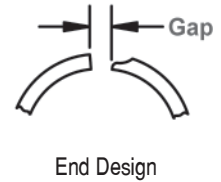

End Design

RING NO.	HOUSING DIAMETER (In.)	GROOVE SIZE				RING SIZE						THRUST LOAD (lbs.)	
		DIAMETER		WIDTH		FREE DIAMETER		THICKNESS		SECTION		RING Safety factor of 3	GROOVE Safety factor of 2
		Dg	Tol.	W	Tol.	Df	Tol.	T	Tol.	S	Tol.		
KLR-331	3.312	3.450		.124		3.483		.115		.248		38952	16154
KLR-337	3.375	3.513		.124		3.547		.115		.248		39693	16461
KLR-343	3.437	3.575		.124		3.609		.115		.248		40422	16763
KLR-350	3.500	3.638		.124		3.673		.115		.248		41163	17071
KLR-356	3.562	3.700	+ .013	.124		3.728	+ .035	.115	± .003	.248		41892	17373
KLR-362	3.625	3.763	- .000	.124		3.799	- .000	.115		.248		42633	17680
KLR-368	3.687	3.825		.124		3.862		.115		.248		43362	17983
KLR-375	3.750	3.888		.124		3.922		.115		.248		44103	18290
KLR-381	3.812	3.950		.124		3.988		.115		.248		44832	18592
KLR-387	3.875	4.013		.124		4.044		.115		.248		45573	18900
KLR-393	3.937	4.075		.124		4.114		.115		.248		46302	19202
KLR-400	4.000	4.158		.163		4.223		.153		.265	± .005	60283	22337
KLR-412	4.125	4.283	+ .021	.163		4.329		.153		.265		62166	23035
KLR-425	4.250	4.408	- .000	.163		4.452		.153		.265		64050	23733
KLR-437	4.375	4.533		.163		4.576		.153		.265		65934	24431
KLR-450	4.500	4.658		.163		4.703	+ .050	.153		.265		67818	25129
KLR-462	4.625	4.783		.163		4.829	- .000	.153		.265		69702	25827
KLR-475	4.750	4.908		.163		4.945		.153		.265		71585	26525
KLR-487	4.875	5.033		.163		5.082		.153		.265		73469	27223
KLR-500	5.000	5.158		.163		5.207		.153		.265		75353	27921
KLR-525	5.250	5.408	+ .024	.163	+ .007	5.460		.153	± .004	.265		79121	29317
KLR-550	5.500	5.658	- .000	.163	- .000	5.719		.153		.265		82888	30713
KLR-575	5.750	5.908		.163		5.965		.153		.265		86656	32109
KLR-600	6.000	6.196		.163		6.256		.153		.316		90424	41563
KLR-625	6.250	6.446		.163		6.508	+ .055	.153		.316		94191	43295
KLR-650	6.500	6.696		.163		6.760	- .000	.153		.316		97959	45027
KLR-675	6.750	6.946		.163		7.013		.153		.316		101727	46759
KLR-700	7.000	7.196		.163		7.266		.153		.316		105494	48490
KLR-725	7.250	7.446		.163		7.541		.153		.316		109262	50222
KLR-750	7.500	7.696		.163		7.762		.153		.316		113030	51954
KLR-775	7.750	7.946		.163		8.023		.153		.316	± .006	116797	53686
KLR-800	8.000	8.196	+ .028	.163		8.276		.153		.316		120565	55418
KLR-825	8.250	8.486	- .000	.203		8.580		.192		.373		147399	68813
KLR-850	8.500	8.736		.203		8.821		.192		.373		151866	70898
KLR-875	8.750	8.986		.203		9.073	+ .070	.192		.373		156332	72983
KLR-900	9.000	9.236		.203		9.326	- .000	.192		.373		160799	75068
KLR-925	9.250	9.486		.203		9.580		.192		.373		165265	77154
KLR-950	9.500	9.736		.203		9.831		.192	± .005	.373		169732	79239
KLR-975	9.750	9.986		.203		10.083		.192		.373		174199	81324
KLR-1000	10.000	10.314		.203		10.414		.192		.435		178665	110977
KLR-1025	10.250	10.564	+ .031	.203		10.660		.192		.435		183132	113751
KLR-1050	10.500	10.814	- .000	.203		10.919		.192		.435	± .007	187599	116526
KLR-1075	10.750	11.064		.203		11.171		.192		.435		192065	119300
KLR-1100	11.000	11.314		.203		11.440	+ .120-.000	.192		.435		196532	122074

# CLR Spiral Shaft Rings

## External, Heavy-Duty Snap Ring

These single-turn snap rings are ideal for applications involving high thrust loads.

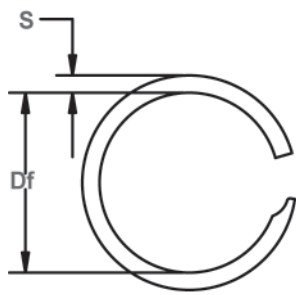

Free Diameter & Ring Measurements

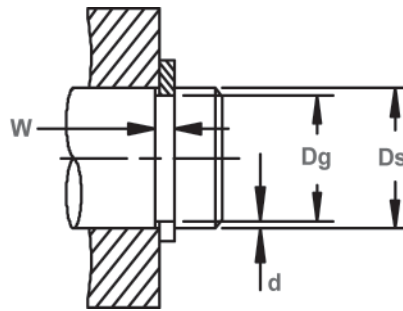

Shaft Diameter & Groove Dimensions

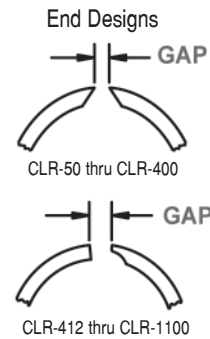

CLR-412 thru CLR-1100

RING NO.	SHAFT DIAMETER (In.)	GROOVE SIZE				FREE DIAMETER		RING SIZE THICKNESS		SECTION		THRUST LOAD (lbs.)		R.P.M. LIMITS Standard Material (Carbon Steel)
		DIAMETER		WIDTH		Df	Tol.	T	Tol.	S	Tol.	RING Safety factor of 3	GROOVE Safety factor of 2	
		Dg	Tol.	W	Tol.									
CLR-50	.500	.476		.043		.471		.037		.055		2325	424	32573
CLR-56	.562	.532	+ .000	.043		.524		.037		.055		2613	596	32410
CLR-62	.625	.595	- .004	.043		.590		.037		.065		2906	663	22107
CLR-68	.687	.655		.043		.649		.037		.065		3194	777	19520
CLR-75	.750	.710		.051		.701	+ .000	.045		.075		4241	1060	22451
CLR-81	.812	.772	+ .000	.051		.764	- .013	.045		.075		4592	1148	17414
CLR-87	.875	.831	- .005	.051		.820		.045		.075		4948	1361	17374
CLR-93	.937	.893		.051		.886		.045		.085		5334	1457	12757
CLR-100	1.000	.952	+ .000	.051		.933		.045		.085		5693	1696	18675
CLR-106	1.062	1.014	- .008	.051		1.004		.045	± .002	.085	+ .003	6045	1802	11446
CLR-112	1.125	1.077		.063		1.069		.057		.128	- .005	7615	1909	12107
CLR-118	1.187	1.131		.063		1.116		.057		.128		8035	2349	15056
CLR-125	1.250	1.188		.063		1.176	+ .000	.057		.128		8461	2739	11970
CLR-131	1.312	1.242		.063		1.223	- .015	.057		.128		8881	3246	13786
CLR-137	1.375	1.297		.063		1.282		.057		.128		9307	3791	11008
CLR-143	1.437	1.359		.073		1.344		.067		.158		11408	3961	11594
CLR-150	1.500	1.422		.073		1.402		.067		.158		11908	4135	12178
CLR-156	1.562	1.470	+ .000	.073	+ .006	1.457		.067		.158		12400	5079	9004
CLR-162	1.625	1.533	- .010	.073	- .000	1.517		.067		.158		12901	5284	9118
CLR-168	1.687	1.595		.073		1.578	+ .000	.067		.158		13393	5485	8595
CLR-175	1.750	1.658		.073		1.640	- .020	.067		.158		13893	5690	8101
CLR-181	1.812	1.720		.073		1.697		.067		.158		14385	5892	8470
CLR-187	1.875	1.783		.073		1.767		.067		.158		14885	6097	6440
CLR-193	1.937	1.819		.085		1.800		.076		.200		16649	8078	8047
CLR-200	2.000	1.882		.085		1.862		.076		.200		17191	8341	7650
CLR-206	2.062	1.944		.085		1.924		.076		.200		17724	8599	7103
CLR-212	2.125	2.007		.085		1.987		.076		.200		18265	8862	6603
CLR-218	2.187	2.069		.085		2.048		.076		.200		18798	9121	6316
CLR-225	2.250	2.132		.085		2.110	+ .000	.076		.200		19340	9384	6040
CLR-231	2.312	2.194		.085		2.171	- .025	.076		.200		19873	9642	5786
CLR-237	2.375	2.257		.085		2.226		.076		.200	+ .004	20414	9905	6343
CLR-243	2.437	2.319		.085		2.296		.076		.200	- .006	20947	10163	5089
CLR-250	2.500	2.382		.085		2.357		.076		.200		21488	10426	4994
CLR-256	2.562	2.444	+ .000	.104		2.415		.095	± .003	.200		26252	10685	5118
CLR-262	2.625	2.507	- .012	.104		2.486		.095		.200		26898	10947	4073
CLR-268	2.687	2.569		.104		2.537		.095		.200		27533	11206	4797
CLR-275	2.750	2.632		.104		2.607		.095		.200		28179	11469	3981
CLR-281	2.812	2.694		.104		2.665		.095		.200		28814	11727	4074
CLR-287	2.875	2.757		.104		2.727		.095		.200		29460	11990	3927
CLR-293	2.937	2.819		.104		2.789	+ .000	.095		.200		30095	12249	3727
CLR-300	3.000	2.882		.104		2.852	- .030	.095		.200		30740	12511	3537
CLR-306	3.062	2.944		.104		2.916		.095		.200		31376	12770	3245
CLR-312	3.125	2.987		.104		2.955		.095		.237		32021	15242	3853
CLR-318	3.187	3.049		.104		3.016		.095		.237	± .005	32657	15544	3731
CLR-325	3.250	3.112		.104		3.079		.095		.237		33302	15851	3557



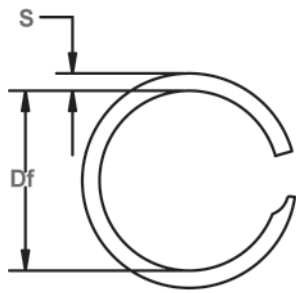

Free Diameter & Ring Measurements

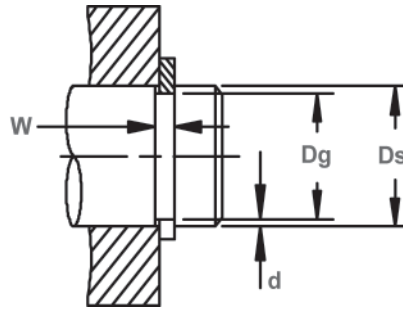

Shaft Diameter & Groove Dimensions

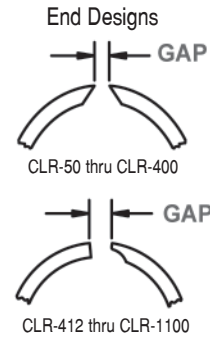

CLR-412 thru CLR-1100

RING NO.	SHAFT DIAMETER (In.)	GROOVE SIZE				FREE DIAMETER		RING SIZE THICKNESS		SECTION		THRUST LOAD (lbs.)		R.P.M. LIMITS Standard Material (Carbon Steel)
		DIAMETER		WIDTH		Df	Tol.	T	Tol.	S	Tol.	RING Safety factor of 3	GROOVE Safety factor of 2	
		Dg	Tol.	W	Tol.									
CLR-331	3.312	3.174		.124		3.140	+.000-.030	.115		.248		39088	16154	3595
CLR-337	3.375	3.237		.124		3.203		.115		.248		39831	16461	3433
CLR-343	3.437	3.299		.124		3.264		.115		.248		40563	16763	3334
CLR-350	3.500	3.362		.124		3.326		.115		.248		41307	17071	3236
CLR-356	3.562	3.424		.124		3.378		.115		.248		42038	17373	3528
CLR-362	3.625	3.487	+.000	.124		3.451	+.000	.115	±.003	.248		42782	17680	2970
CLR-368	3.687	3.549	-.014	.124		3.512	-.035	.115		.248		43514	17983	2890
CLR-375	3.750	3.612		.124		3.570		.115		.248		44257	18290	2964
CLR-381	3.812	3.674		.124		3.636		.115		.248		44989	18592	2701
CLR-387	3.875	3.737		.124		3.689		.115		.248		45732	18900	2934
CLR-393	3.937	3.799		.124		3.760		.115		.248	±.005	46464	19202	2529
CLR-400	4.000	3.862		.124		3.828		.115		.248		47208	19509	2264
CLR-412	4.125	3.967	+.000	.163		3.930		.153		.265		62126	23035	2367
CLR-425	4.250	4.092	-.021	.163		4.050		.153		.265		64008	23733	2350
CLR-437	4.375	4.217		.163		4.174		.153		.265		65891	24431	2215
CLR-450	4.500	4.342		.163		4.297	+.000	.153		.265		67774	25129	2116
CLR-462	4.625	4.467		.163		4.421	-.051	.153		.265		69656	25827	2001
CLR-475	4.750	4.592		.163		4.530		.153		.265		71539	26525	2193
CLR-487	4.875	4.717		.163		4.668		.153		.265		73421	27223	1816
CLR-500	5.000	4.842		.163		4.792		.153		.265		75304	27921	1724
CLR-525	5.250	5.092	+.000	.163	+.007	5.039		.153	±.004	.265		79069	29317	
CLR-550	5.500	5.342	-.024	.163	-.000	5.292		.153		.265		82834	30713	
CLR-575	5.750	5.592		.163		5.535		.153		.265		86599	32109	
CLR-600	6.000	5.804		.163		5.744		.153		.316		90365	41563	
CLR-625	6.250	6.054		.163		5.992	+.000	.153		.316		94130	43295	
CLR-650	6.500	6.304		.163		6.236	-.060	.153		.316		97985	45027	
CLR-675	6.750	6.554		.163		6.486		.153		.316	±.006	101727	46759	
CLR-700	7.000	6.804		.163		6.734		.153		.316		105494	48490	
CLR-725	7.250	7.054		.163		6.993		.153		.316		109262	50222	
CLR-750	7.500	7.304		.163		7.219		.153		.316		113030	51954	
CLR-775	7.750	7.554		.163		7.477		.153		.316		116797	53686	
CLR-800	8.000	7.764	+.000	.203		7.683	+.000	.192		.435		142932	66727	
CLR-825	8.250	8.014	-.028	.203		7.940	-.070	.192		.435		147399	68813	
CLR-850	8.500	8.264		.203		8.179		.192		.435		151866	70898	
CLR-875	8.750	8.514		.203		8.427		.192		.435		156332	72983	
CLR-900	9.000	8.764		.203		8.673		.192		.435		160799	75068	
CLR-925	9.250	9.014		.203		8.922		.192		.435	±.007	165265	77154	
CLR-950	9.500	9.240		.203		9.130		.192	±.005	.435		169732	87297	
CLR-975	9.750	9.490		.203		9.393		.192		.435		174199	98594	
CLR-1000	10.000	9.686		.203		9.586		.192		.500		178665	110977	
CLR-1025	10.250	9.936	+.000	.203		9.826	+.000	.192		.500		183132	113751	
CLR-1050	10.500	10.186	-.031	.203		10.081	-.091	.192		.500		187599	116526	
CLR-1075	10.750	10.436		.203		10.329		.192		.500		192056	119300	
CLR-1100	11.000	10.686		.203		10.584		.192		.500		196532	122074	

CONTACT FACTORY REGARDING MAX RPM LIMITS FOR LARGER DIAMETER RINGS



# DKR Spiral Housing Rings

## DIN 472 Groove

**Internal, Heavy Duty DIN**  
 These 2-turn rings are ideal for applications with high thrust loads and are designed to fit into a groove established by DIN specifications.

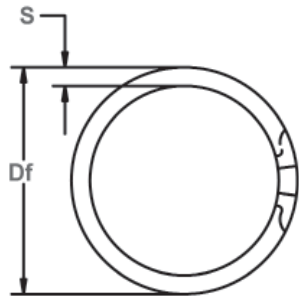

Free Diameter & Ring Measurements

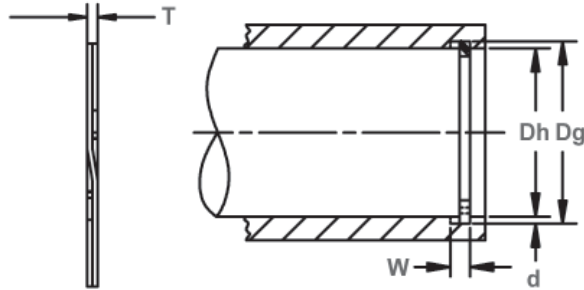

Housing Diameter & Groove Dimensions

RING NO.	HOUSING DIAMETER (mm)	GROOVE SIZE					RING SIZE					THRUST LOAD (N)			
		DIAMETER			WIDTH		DEPTH	FREE DIAMETER			THICKNESS		SECTION	RING Safety factor of 3	GROOVE Safety factor of 2
		Dh	Dg	Tol.	W	Tol.	d	Df	Tol.	T	Tol.	S	Tol.		
DKR-13	13	13,6		1,10		0,3	13,72		0,99		1,40		13474	1901	
DKR-14	14	14,6	+0,11	1,10		0,3	14,75		0,99		1,40		14510	2047	
DKR-15	15	15,7	-0,00	1,10		0,4	15,85		0,99		1,40		15547	2559	
DKR-16	16	16,8		1,10		0,4	16,97		0,99		1,65		16583	3119	
DKR-17	17	17,8		1,10		0,4	17,98	+0,33	0,99		1,65		17620	3314	
DKR-18	18	19,0		1,10		0,5	19,18	-0,00	0,99		1,91		18656	4386	
DKR-19	19	20,0	+0,13	1,10		0,5	20,19		0,99		1,91		19693	4630	
DKR-20	20	21,0	-0,00	1,10		0,5	21,21		0,99		1,91		20729	4874	
DKR-21	21	22,0		1,10		0,5	22,23		0,99		1,91		21766	5117	
DKR-22	22	23,0		1,10		0,5	23,23		0,99		1,91		22802	5361	
DKR-23	23	24,1		1,30		0,6	24,33		1,14		2,18		23853	6165	
DKR-24	24	25,2		1,30	+0,14	0,6	25,45		1,14	±0,05	2,18	±0,10	24891	7018	
DKR-25	25	26,2	+0,21	1,30	-0,00	0,6	26,45		1,14		2,18		25928	7310	
DKR-26	26	27,2	-0,00	1,30		0,6	27,48		1,14		2,18		26965	7603	
DKR-27	27	28,4		1,30		0,7	28,68		1,14		2,41		28002	9211	
DKR-28	28	29,4		1,30		0,7	29,69		1,14		2,41		29039	9552	
DKR-29	29	30,4		1,30		0,7	30,71		1,14		2,41		30076	9893	
DKR-30	30	31,4		1,30		0,7	31,71	+0,38	1,14		2,41		31113	10235	
DKR-31	31	32,7		1,30		0,9	33,02	-0,00	1,14		2,41		32150	12842	
DKR-32	32	33,7		1,30		0,9	34,04		1,14		2,41		33187	13256	
DKR-33	33	34,7	+0,25	1,30		0,9	35,05		1,14		2,41		34224	13670	
DKR-34	34	35,7	-0,00	1,60		0,9	36,07		1,44		3,25		44541	14085	
DKR-35	35	37,0		1,60		1,0	37,38		1,44		3,25		45851	17058	
DKR-36	36	38,0		1,60		1,0	38,39		1,44		3,25		47161	17545	
DKR-37	37	39,0		1,60		1,0	39,40		1,44		3,25		48471	18032	
DKR-38	38	40,0		1,60		1,0	40,41		1,44		3,25		49781	18520	

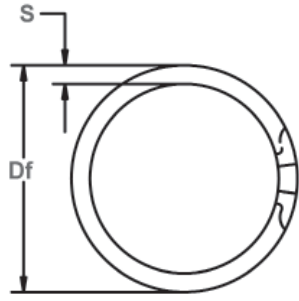

Free Diameter & Ring Measurements

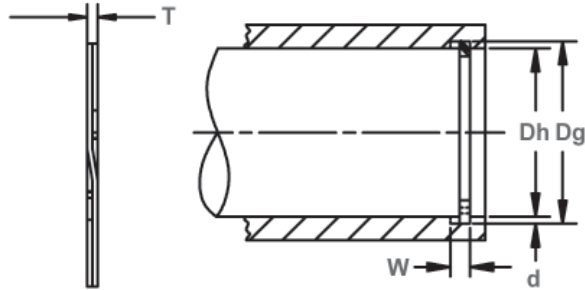

Housing Diameter & Groove Dimensions

RING NO.	HOUSING DIAMETER (mm)	GROOVE SIZE					RING SIZE						THRUST LOAD (N)			
		DIAMETER			WIDTH		DEPTH	FREE DIAMETER			THICKNESS		SECTION		RING Safety factor of 3	GROOVE Safety factor of 2
		Dh	Dg	Tol.	W	Tol.	d	Df	Tol.	T	Tol.	S	Tol.			
DKR-40	40	42,5		1,85		1,3	42,93		1,69		4,01		61498	24368		
DKR-41	41	43,5	+0,25	1,85		1,3	43,94		1,69		4,01		63036	24977		
DKR-42	42	44,5	-0,00	1,85		1,3	44,96	+0,51	1,69	±0,05	4,01	±0,10	64573	25586		
DKR-45	45	47,5		1,85		1,3	47,98	-0,00	1,69		4,01		69186	27414		
DKR-47	47	49,5		1,85		1,3	49,99		1,69		4,01		72261	28633		
DKR-48	48	50,5		1,85		1,3	51,00		1,69		4,01		73798	29242		
DKR-50	50	53,0		2,15		1,5	53,54		1,93		5,08		87790	36552		
DKR-51	51	54,0		2,15		1,5	54,54		1,93		5,08		89546	37283		
DKR-52	52	55,0		2,15		1,5	55,55		1,93		5,08		91302	38014		
DKR-55	55	58,0		2,15		1,5	58,57		1,93		5,08		96569	40207		
DKR-56	56	59,0		2,15	+0,14	1,5	59,59	+0,63	1,93		5,08		98325	40938		
DKR-57	57	60,0		2,15	-0,00	1,5	60,60	-0,00	1,93		5,08		100081	41669		
DKR-58	58	61,0		2,15		1,5	61,62		1,93		5,08		101836	42400		
DKR-60	60	63,0	+0,30	2,15		1,5	63,63		1,93		5,08		105348	43863		
DKR-62	62	65,0	-0,00	2,15		1,5	65,66		1,93	±0,08	5,08	±0,12	108860	45325		
DKR-63	63	66,0		2,15		1,5	66,67		1,93		5,08		110615	46056		
DKR-64	64	67,0		2,15		1,5	67,67		1,93		5,08		112371	46787		
DKR-65	65	68,0		2,65		1,5	68,67		2,41		5,08		135725	47518		
DKR-67	67	70,0		2,65		1,5	70,67		2,41		5,08		139901	48980		
DKR-68	68	71,0		2,65		1,5	71,67		2,41		5,08		141989	49711		
DKR-70	70	73,0		2,65		1,5	73,67		2,41		5,08		146165	51173		
DKR-72	72	75,0		2,65		1,5	75,67	+0,76	2,41		5,08		150341	52635		
DKR-75	75	78,0		2,65		1,5	78,68	-0,00	2,41		5,08		156605	54828		
DKR-76	76	79,0		2,65		1,5	79,68		2,41		5,08		158694	55559		
DKR-78	78	81,0	+0,35	2,65		1,5	81,69		2,41		5,08		162870	57021		
DKR-80	80	83,5	-0,00	2,65		1,8	84,19		2,41		6,05	±0,13	167046	68231		



# DKR Spiral Housing Rings

## DIN 472 Groove

**Internal, Heavy Duty DIN**  
 These 2-turn rings are ideal for applications with high thrust loads and are designed to fit into a groove established by DIN specifications.

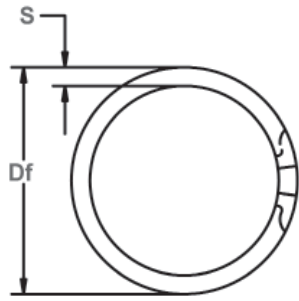

Free Diameter & Ring Measurements

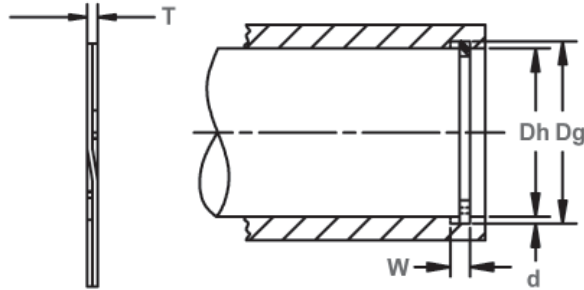

Housing Diameter & Groove Dimensions

RING NO.	HOUSING DIAMETER (mm)	GROOVE SIZE					RING SIZE						THRUST LOAD (N)			
		DIAMETER			WIDTH		DEPTH	FREE DIAMETER			THICKNESS		SECTION		RING Safety factor of 3	GROOVE Safety factor of 2
		Dg	Tol.		W	Tol.	d	Df	Tol.	T	Tol.	S	Tol.			
DKR-82	82	85,5		2,65	+0,14 -0,00	1,8	86,20	+0,76 -0,00	2,41		6,05		171222	69936		
DKR-85	85	88,5		3,15		1,8	89,20		2,91		6,05		214309	72495		
DKR-88	88	91,5	+0,35	3,15		1,8	92,21		2,91		6,05		221873	75054		
DKR-90	90	93,5	-0,00	3,15		1,8	94,21	+0,89	2,91	±0,08	6,05		226915	76759		
DKR-92	92	95,5		3,15		1,8	96,22	-0,00	2,91		6,05		231958	78465		
DKR-95	95	98,5		3,15		1,8	99,24		2,91		6,05		239522	81024		
DKR-98	98	101,5		3,15		1,8	102,26		2,91		6,05		247068	83583		
DKR-100	100	103,5		3,15		1,8	104,29		2,91		6,05		252128	85288		
DKR-102	102	106,0		4,15		2,0	106,79		3,89		6,73		343778	99422		
DKR-105	105	109,0		4,15		2,0	109,79		3,89		6,73	±0,13	353889	102346		
DKR-108	108	112,0	+0,54	4,15		2,0	112,80		3,89		6,73		364000	105270		
DKR-110	110	114,0	-0,00	4,15		2,0	114,83		3,89		6,73		370741	107220		
DKR-112	112	116,0		4,15	+0,18	2,0	116,84		3,89		6,73		377482	109169		
DKR-115	115	119,0		4,15	-0,00	2,0	119,86	+1,30	3,89		6,73		387593	112093		
DKR-120	120	124,0		4,15		2,0	124,92	-0,00	3,89		6,73		404445	116967		
DKR-125	125	129,0		4,15		2,0	129,97		3,89	±0,10	6,73		421297	121840		
DKR-127	127	131,0		4,15		2,0	131,97		3,89		6,73		428038	123790		
DKR-130	130	134,0		4,15		2,0	135,00		3,89		6,73		438149	126714		
DKR-135	135	139,0	+0,63	4,15		2,0	140,03		3,89		6,73		455001	131588		
DKR-140	140	144,0	-0,00	4,15		2,0	145,11		3,89		6,73		471852	136461		
DKR-145	145	149,0		4,15		2,0	150,11		3,89		6,73		488704	141335		
DKR-150	150	155,0		4,15		2,5	156,13		3,89		7,92		505556	182761		
DKR-155	155	160,0		4,15		2,5	161,19	+1,40	3,89		7,92	±0,15	522408	188853		
DKR-160	160	165,0		4,15		2,5	166,22	-0,00	3,89		7,92		539260	194945		
DKR-165	165	170,0		4,15		2,5	171,27		3,89		7,92		556112	201037		
DKR-170	170	175,0		4,15		2,5	176,33		3,89		7,92		572964	207129		

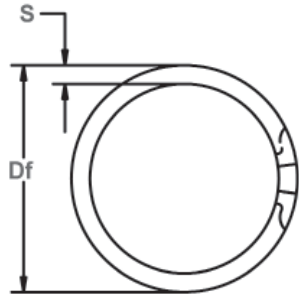

Free Diameter & Ring Measurements

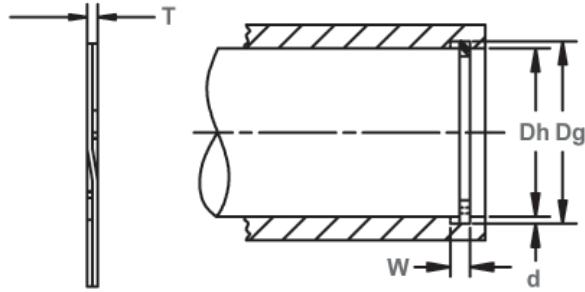

Housing Diameter & Groove Dimensions

RING NO.	HOUSING DIAMETER (mm)	GROOVE SIZE					RING SIZE						THRUST LOAD (N)			
		DIAMETER			WIDTH		DEPTH	FREE DIAMETER			THICKNESS		SECTION		RING Safety factor of 3	GROOVE Safety factor of 2
		Dg	Tol.		W	Tol.	d	Df	Tol.	T	Tol.	S	Tol.			
DKR-175	175	180,0	+0,63 -0,00	4,15		2,5	181,36	+1,40	3,89		7,92		589815	213221		
DKR-180	180	185,0	+0,72 -0,00	4,15	+0,18 -0,00	2,5	186,39	-0,00	3,89	±0,10	7,92	±0,15	606667	219313		
DKR-185	185	190,0		4,15		2,5	191,44	3,89	7,92		623519		225405			
DKR-190	190	195,0		4,15		2,5	196,47	3,89	7,92		640371		231497			
DKR-195	195	200,0		4,15		2,5	201,52	3,89	7,92		657223		237589			
DKR-200	200	205,0		4,15		2,5	206,58	3,89	7,92		674075		243681			
DKR-210	210	216,0		5,15		3,0	217,58	+1,78	4,86		9,53		884268	307038		
DKR-220	220	226,0		5,15		3,0	227,66	-0,00	4,86		9,53		926376	321659		
DKR-230	230	236,0		5,15		3,0	237,72	4,86	9,53		968484		336280			
DKR-240	240	246,0		5,15		3,0	247,80	4,86	9,53		1010592		350900			
DKR-250	250	256,0		5,15		3,0	257,89	4,86	9,53		1052700		365521			
DKR-260	260	268,0	5,15	4,0	269,93	4,86	11,18	1094808	506856							
DKR-270	270	278,0	+0,81 -0,00	5,15	4,0	280,01	4,86	11,18	1136916	526351						
DKR-280	280	288,0	5,15	4,0	290,09	4,86	11,18	1179024	545845							
DKR-290	290	298,0	5,15	4,0	300,15	4,86	±0,13	11,18	1221132	565340						
DKR-300	300	308,0	5,15	4,0	310,24	+3,05	4,86	11,18	1263241	584834						
DKR-310	310	320,0	+0,89 -0,00	6,20	+0,22 -0,00	5,0	322,25	-0,00	5,87	±0,19	12,70	±0,19	1576625	755411		
DKR-320	320	330,0		6,20		5,0	332,33	5,87	12,70		1627484		779779			
DKR-330	330	340,0		6,20		5,0	342,42	5,87	12,70		1678342		804147			
DKR-340	340	350,0		6,20		5,0	352,50	5,87	12,70		1729201		828515			
DKR-350	350	360,0		6,20		5,0	362,56	5,87	12,70		1780060		852883			
DKR-360	360	370,0		6,20		5,0	372,64	+3,56 -0,00	5,87		12,70		1830919	877251		
DKR-370	370	380,0		6,20		5,0	382,73	5,87	12,70		1881778		901619			
DKR-380	380	390,0		6,20		5,0	392,79	5,87	12,70		1932637		925987			
DKR-390	390	400,0		6,20		5,0	402,84	5,87	12,70		1983496		950355			
DKR-400	400	410,0		6,20		5,0	412,93	5,87	12,70		2034354		974723			

# DCR Spiral Shaft Rings

## DIN 471 Groove

**External, Heavy Duty DIN**  
 These 2-turn rings are ideal for applications with high thrust loads and are designed to fit into a groove established by DIN specifications.

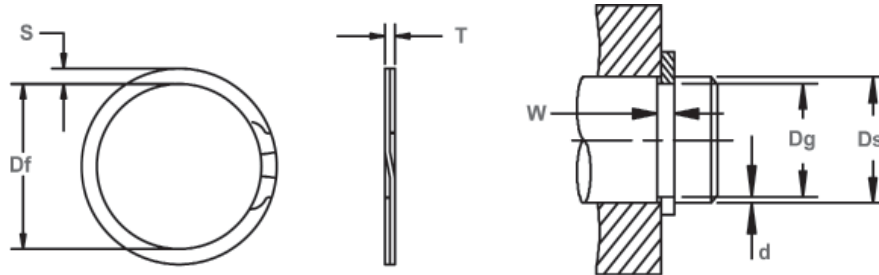

Free Diameter & Ring Measurements

Shaft Diameter & Groove Dimensions

RING NO.	SHAFT DIAMETER (mm)	GROOVE SIZE					RING SIZE						THRUST LOAD (N)		R.P.M. LIMITS Standard Material (Carbon Steel)
		DIAMETER		WIDTH		DEPTH	FREE DIAMETER		THICKNESS		SECTION		RING Safety factor of 3	GROOVE Safety factor of 2	
		Dg	Tol.	W	Tol.	d	Df	Tol.	T	Tol.	S	Tol.			
DCR-13	13	12,4		1,10		0,3	12,27		0,99		1,4		13474	1901	22915
DCR-14	14	13,4		1,10		0,3	13,26		0,99		1,4		14510	2047	19967
DCR-15	15	14,3	+0,00	1,10		0,4	14,15		0,99		1,4		15547	2559	17836
DCR-16	16	15,2	-0,11	1,10		0,4	15,04		0,99		1,65		16583	3119	18132
DCR-17	17	16,2		1,10		0,4	16,04		0,99		1,65		17620	3314	15677
DCR-18	18	17,0		1,30		0,5	16,83		1,14		1,91		18668	4386	16195
DCR-19	19	18,0		1,30		0,5	17,83	+0,00	1,14		1,91		19705	4630	14221
DCR-20	20	19,0		1,30		0,5	18,82	-0,33	1,14		1,91		20742	4874	12948
DCR-21	21	20,0	+0,00	1,30		0,5	19,79		1,14		1,91		21779	5117	12475
DCR-22	22	21,0	-0,13	1,30		0,5	20,78		1,14		1,91		22816	5361	11421
DCR-23	23	22,0		1,30		0,5	21,77		1,14		1,91		23853	5605	10495
DCR-24	24	22,9		1,30		0,6	22,66		1,14		2,18		24891	6433	10825
DCR-25	25	23,9		1,30		0,6	23,65		1,14		2,18		25928	6701	10020
DCR-26	26	24,9	+0,00	1,30		0,6	24,64		1,14		2,18		26965	6969	9301
DCR-27	27	25,6	-0,21	1,30		0,7	25,34		1,14	±0,05	2,18	±0,10	28002	9211	8721
DCR-28	28	26,6		1,60		0,7	26,34		1,44		2,39		36681	9552	8609
DCR-29	29	27,6		1,60		0,7	27,33		1,44		2,39		37991	9893	8060
DCR-30	30	28,6		1,60		0,7	28,32		1,44		2,39		39301	10235	7562
DCR-32	32	30,3		1,60		0,9	30,00	+0,00	1,44		3,25		41921	13256	8686
DCR-33	33	31,3		1,60	+0,14	0,9	30,99	-0,38	1,44		3,25		43231	13670	8205
DCR-34	34	32,3		1,60	-0,00	0,9	31,98		1,44		3,25		44541	14085	7763
DCR-35	35	33,0		1,60		1,0	32,66		1,44		3,25		45851	17058	7628
DCR-36	36	34,0		1,85		1,0	33,65		1,69		4,01		55349	17545	8474
DCR-38	38	36,0	+0,00	1,85		1,0	35,64		1,69		4,01		58424	18520	7556
DCR-40	40	37,5	-0,25	1,85		1,3	37,11		1,69		4,01		61498	24368	7181
DCR-42	42	39,5		1,85		1,3	39,09		1,69		4,01		64573	25586	6546
DCR-45	45	42,5		1,85		1,3	42,06	+0,00	1,69		4,01		69186	27414	5740
DCR-46	46	43,5		1,85		1,3	43,05	-0,51	1,69		4,01		70723	28023	5505
DCR-47	47	44,5		1,85		1,3	44,04		1,69		4,01		72261	28633	5283
DCR-48	48	45,5		1,85		1,3	45,03		1,69		4,01		73798	29242	5075
DCR-50	50	47,0		2,15		1,5	46,53		1,93		5,08		87790	36552	5651
DCR-52	52	49,0		2,15		1,5	48,51		1,93		5,08		91302	38014	5251
DCR-54	54	51,0		2,15		1,5	50,50		1,93		5,08		94813	39476	4842
DCR-55	55	52,0		2,15		1,5	51,49		1,93		5,08		96569	40207	4680
DCR-56	56	53,0		2,15		1,5	52,48	+0,00	1,93		5,08		98325	40938	4525
DCR-58	58	55,0		2,15		1,5	54,43	-0,63	1,93		5,08		101836	42400	4359
DCR-60	60	57,0		2,15		1,5	56,42		1,93		5,08		105348	43863	4050
DCR-62	62	59,0		2,15		1,5	58,42		1,93		5,08	±0,12	108860	45325	3738
DCR-63	63	60,0		2,15		1,5	59,39		1,93		5,08		110615	46056	3691
DCR-65	65	62,0	+0,00	2,65		1,5	61,39		2,41	±0,08	5,08		135725	47518	3430
DCR-67	67	64,0	-0,30	2,65		1,5	63,37		2,41		5,08		139901	48980	3239
DCR-68	68	65,0		2,65		1,5	64,34		2,41		5,08		141989	49711	3201
DCR-70	70	67,0		2,65		1,5	66,34		2,41		5,08		146165	51173	2982
DCR-72	72	69,0		2,65		1,5	68,33		2,41		5,08		150341	52635	2805
DCR-75	75	72,0		2,65		1,5	71,33	+0,00	2,41		5,08		156605	54828	2537
DCR-77	77	74,0		2,65		1,5	73,33	-0,76	2,41		5,08		160782	56290	2379
DCR-78	78	75,0		2,65		1,5	74,33		2,41		5,08		162870	57021	2304
DCR-80	80	76,5		2,65		1,8	75,81		2,41		6,05	±0,13	167046	68231	2576
DCR-82	82	78,5		2,65		1,8	77,81		2,41		6,05		171222	69936	2425

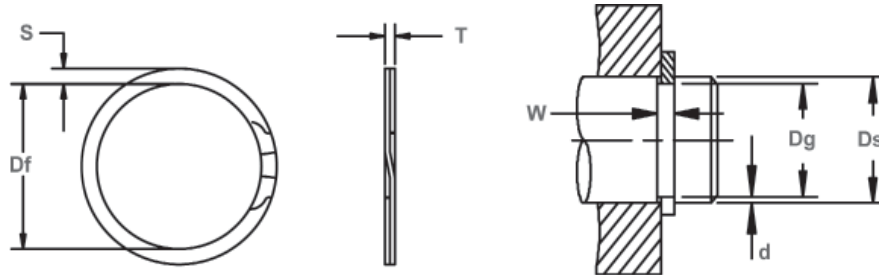

Free Diameter & Ring Measurements

Shaft Diameter & Groove Dimensions

RING NO.	SHAFT DIAMETER (mm)	GROOVE SIZE					RING SIZE					THRUST LOAD (N)		R.P.M. LIMITS Standard Material (Carbon Steel)	
		DIAMETER		WIDTH		DEPTH	FREE DIAMETER		THICKNESS		SECTION		RING Safety factor of 3		GROOVE Safety factor of 2
		Dg	Tol.	W	Tol.	d	Df	Tol.	T	Tol.	S	tol.			
DCR-85	85	81,5		3,15		1,8	80,80	+0,00 -0,76	2,91		6,35		214309	72495	2333
DCR-88	88	84,5		3,15		1,8	83,80		2,91		6,35		221873	75054	2143
DCR-90	90	86,5	+0,00	3,15		1,8	85,80	+0,00	2,91	±0,08	6,35		226915	76759	2029
DCR-95	95	91,5	-0,35	3,15		1,8	90,80	-0,89	2,91		6,35		239522	81024	1777
DCR-98	98	94,5		3,15		1,8	93,79		2,91		6,35		247086	83583	1659
DCR-100	100	96,5		3,15		1,8	95,79		2,91		6,35		252128	85288	1579
DCR-102	102	98,0		4,15		2,0	97,29		3,89		6,73		343778	99422	1530
DCR-105	105	101,0		4,15		2,0	100,28		3,89		6,73	±0,13	353889	102346	1435
DCR-108	108	104,0	+0,00	4,15		2,0	103,25		3,89		6,73		364000	105270	1368
DCR-110	110	106,0	-0,54	4,15		2,0	105,23		3,89		6,73		370741	107220	1391
DCR-115	115	111,0		4,15		2,0	110,19		3,89		6,73		387593	112093	1280
DCR-120	120	116,0		4,15		2,0	115,16	+0,00	3,89		6,73		404445	116967	1175
DCR-125	125	121,0		4,15		2,0	120,12	-1,30	3,89		6,73		421297	121840	1088
DCR-130	130	126,0		4,15		2,0	125,07		3,89		6,73		438149	126714	1017
DCR-135	135	131,0		4,15		2,0	130,02		3,89		6,73		455001	131588	952
DCR-140	140	136,0		4,15		2,0	134,98		3,89		6,73		471852	136461	888
DCR-145	145	141,0		4,15		2,0	139,93		3,89	±0,10	6,73		488704	141335	835
DCR-150	150	145,0	+0,00	4,15	+0,18	2,5	143,91		3,89		7,92		505556	182761	788
DCR-155	155	150,0	-0,63	4,15	-0,00	2,5	148,89		3,89		7,92		522408	188853	733
DCR-160	160	155,0		4,15		2,5	153,85		3,89		7,92		539260	194945	690
DCR-165	165	160,0		4,15		2,5	158,80	+0,00	3,89		7,92		556112	201037	753
DCR-170	170	165,0		4,15		2,5	163,75	-1,52	3,89		7,92		572964	207129	715
DCR-175	175	170,0		4,15		2,5	168,73		3,89		7,92		589815	213221	671
DCR-180	180	175,0		4,15		2,5	173,69		3,89		7,92		606667	219313	636
DCR-185	185	180,0		4,15		2,5	178,66		3,89		7,92	±0,15	623519	225405	601
DCR-190	190	185,0		4,15		2,5	183,59		3,89		7,92		640371	231497	577
DCR-195	195	190,0		4,15		2,5	188,54		3,89		7,92		657223	237589	551
DCR-200	200	195,0		4,15		2,5	193,54		3,89		7,92		674075	243681	518
DCR-205	205	199,0	+0,00	5,15		3,0	197,54	+0,00	4,86		11,18		863214	299727	495
DCR-210	210	204,0	-0,72	5,15		3,0	202,54	-1,78	4,86		11,18		884268	307038	466
DCR-220	220	214,0		5,15		3,0	212,47		4,86		11,18		926376	321659	425
DCR-230	230	224,0		5,15		3,0	222,40		4,86		11,18		968484	336280	527
DCR-240	240	234,0		5,15		3,0	232,33		4,86		11,18		1010592	350900	486
DCR-250	250	244,0		5,15		3,0	242,24		4,86		11,18		1052700	365521	451
DCR-260	260	252,0		5,15		4,0	250,19		4,86		12,70		1094808	506856	424
DCR-270	270	262,0		5,15		4,0	260,15	+0,00	4,86		12,70		1136916	526351	390
DCR-280	280	272,0	+0,00	5,15		4,0	270,08	-2,30	4,86		12,70		1179024	545845	363
DCR-290	290	282,0	-0,81	5,15		4,0	279,98		4,86	±0,13	12,70		1221132	565340	382
DCR-300	300	292,0		5,15		4,0	289,92		4,86		12,70		1263241	584834	357
DCR-310	310	300,0		6,20		5,0	297,84		5,87		15,88		576625	755411	342
DCR-320	320	310,0		6,20		5,0	307,84		5,87		15,88		627484	779779	316
DCR-330	330	320,0		6,20		5,0	317,75		5,87		15,88	±0,19	1678342	804147	299
DCR-340	340	330,0		6,20		5,0	327,69		5,87		15,88		729201	828515	343
DCR-350	350	340,0	+0,00	6,20	+0,22	5,0	337,64	+0,00	5,87		15,88		1780060	852883	322
DCR-360	360	350,0	-0,89	6,20	-0,00	5,0	347,57	-2,80	5,87		15,88		1830919	877251	305
DCR-370	370	360,0		6,20		5,0	357,48		5,87		15,88		1881778	901619	291
DCR-380	380	370,0		6,20		5,0	367,41		5,87		15,88		1932637	925987	276
DCR-390	390	380,0		6,20		5,0	377,34		5,87		15,88		1983496	950355	262
DCR-400	400	390,0		6,20		5,0	387,25		5,87		15,88		2034354	974723	251



# DKL Spiral Housing Rings

## DIN 472 Groove

### Internal, Heavy-Duty, Metric

These snap rings are ideal for applications with high thrust loads and are designed to fit into a groove established by DIN specifications.

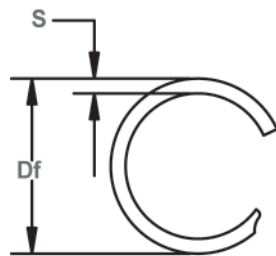

Free Diameter & Ring Measurements

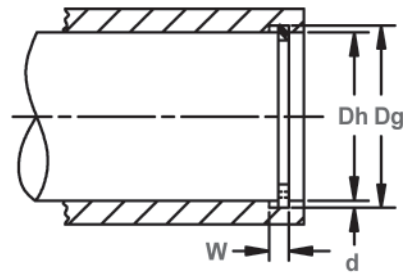
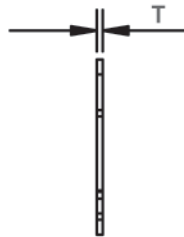

Housing Diameter & Groove Dimensions

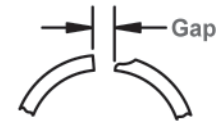

End Design

RING NO.	HOUSING DIAMETER (mm)	GROOVE SIZE				RING SIZE						THRUST LOAD (N)	
		DIAMETER		WIDTH		FREE DIAMETER		THICKNESS		SECTION		RING Safety factor of 3	GROOVE Safety factor of 2
		Dh	Dg	Tol.	W	Tol.	Df	Tol.	T	Tol.	S		
DKL-13	13	13,60		1,10		13,73		0,94		1,40		10591	1931
DKL-14	14	14,60	+0,11	1,10		14,74		0,94		1,40		11396	2077
DKL-15	15	15,70	-0,00	1,10		15,85		0,94		1,40		12224	2602
DKL-16	16	16,80		1,10		16,90		0,94		1,65		13029	3172
DKL-17	17	17,80		1,10		17,97	+0,33	0,94		1,65		13838	3367
DKL-18	18	19,00		1,10		19,18	-0,00	0,94		1,90		14666	4457
DKL-19	19	20,00	+0,13	1,10		20,25		0,94		1,90		15471	5702
DKL-20	20	21,00	-0,00	1,10		21,20		0,94		1,90		16276	4951
DKL-21	21	22,00		1,10		22,21		0,94		1,90		17103	5200
DKL-22	22	23,00		1,10		23,22		0,94		1,90		17913	5445
DKL-23	23	24,00		1,10		24,23		0,94		1,90		18736	5698
DKL-24	24	25,20	+0,21	1,30		25,40		1,15		2,15		23927	6539
DKL-25	25	26,20	-0,00	1,30		26,45		1,15	±0,05	2,15	±0,10	24914	6806
DKL-26	26	27,20		1,30		27,46		1,15		2,15		25929	7082
DKL-27	27	28,20		1,30		28,47		1,15		2,38		26916	7353
DKL-28	28	29,40		1,30		29,68		1,15		2,38		27904	9702
DKL-29	29	30,40		1,30		30,69	+0,38	1,15		2,38		28918	10053
DKL-30	30	31,40		1,30		31,79	-0,00	1,15		2,38		29905	10395
DKL-31	31	32,70		1,30		33,01		1,15		2,38		30893	12660
DKL-32	32	33,70		1,30		33,93		1,15		2,38		31907	13073
DKL-33	33	34,70		1,30	+0,14	35,03		1,15		2,38		32895	13478
DKL-34	34	35,70		1,60	-0,00	36,04		1,44		3,25		40319	13892
DKL-35	35	37,00	+0,25	1,60		37,35		1,44		3,25		41493	16899
DKL-36	36	38,00	-0,00	1,60		38,36		1,44		3,25		42663	17375
DKL-37	37	39,00		1,60		39,37		1,44		3,25		43868	17869
DKL-38	38	40,00		1,60		40,44		1,44		3,25		45043	18344
DKL-40	40	42,50		1,85		42,86		1,69		4,01		55621	24265
DKL-41	41	43,50		1,85		43,91		1,69		4,01		56995	24866
DKL-42	42	44,50		1,85		44,92	+0,51	1,69		4,01		58410	25484
DKL-45	45	47,50		1,85		47,88	-0,00	1,69		4,01		62578	27303
DKL-47	47	49,50		1,85		49,97		1,69		4,01		65331	28504
DKL-48	48	50,50		1,85		50,98		1,69		4,01		66741	29118
DKL-50	50	53,00		2,15		53,50		1,93		5,08		75282	36529
DKL-51	51	54,00		2,15		54,43		1,93		5,08		76776	37249
DKL-52	52	55,00		2,15		55,52		1,93		5,08		78266	37974
DKL-55	55	58,00		2,15		58,55		1,93		5,08		82777	40163
DKL-56	56	59,00		2,15		59,56	+0,63	1,93		5,08		84307	40906
DKL-57	57	60,00	+0,30	2,15		60,68	-0,00	1,93		5,08		85797	41631
DKL-58	58	61,00	-0,00	2,15		61,58		1,93	±0,08	5,08	±0,13	87287	42352
DKL-60	60	63,00		2,15		63,60		1,93		5,08		90308	43819
DKL-62	62	65,00		2,15		65,58		1,93		5,08		93328	45283
DKL-63	63	66,00		2,15		66,63		1,93		5,08		94823	46008
DKL-64	64	67,00		2,65		67,64		2,41		5,08		114742	46751
DKL-65	65	68,00		2,65		68,70		2,41		5,08		116517	47471
DKL-67	67	70,00		2,65		70,54	+0,76	2,41		5,08		120115	48939
DKL-68	68	71,00		2,65		71,84	-0,00	2,41		5,08		121890	49660
DKL-70	70	73,00		2,65		73,64		2,41		5,08		125489	51128





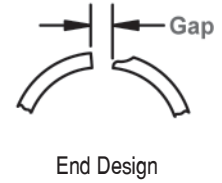
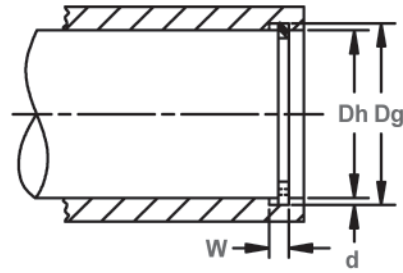
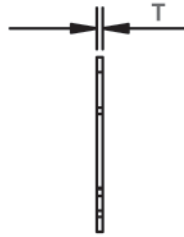
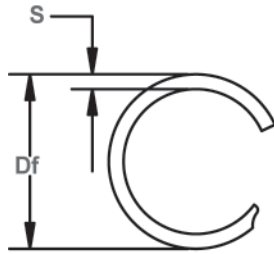

Free Diameter & Ring Measurements

Housing Diameter & Groove Dimensions

RING NO.	HOUSING DIAMETER (mm)	GROOVE SIZE				RING SIZE				THRUST LOAD (N)			
		DIAMETER		WIDTH		FREE DIAMETER		THICKNESS		SECTION	RING Safety factor of 3	GROOVE Safety factor of 2	
		Dh	Dg	Tol.	W	Tol.	Df	Tol.	T				Tol.
DKL-72	72	75.00	+0,30	2,65	+0,14	75,72	+0,76	2,41	±0,08	5,08	±0,13	129083	52591
DKL-75	75	78,00	-0,00	2,65		78,75		2,41		5,08			
DKL-76	76	79,00		2,65		79,88		2,41		5,08			
DKL-78	78	81,00	+0,35	2,65	-0,00	81,73	-0,00	2,41	±0,08	5,08	±0,13	139830	56968
DKL-80	80	83,50		2,65		84,30		2,41		6,02			
DKL-82	82	85,50		2,65		86,32		2,41		6,02			
DKL-85	85	88,50	-0,00	3,15	+0,89	89,35	-0,00	2,91	±0,10	6,30	±0,15	175046	72595
DKL-88	88	91,50		3,15		92,38		2,91		6,30			
DKL-90	90	93,50		3,15		94,70		2,91		6,30			
DKL-92	92	95,50	3,15	96,50	2,91	6,30							
DKL-95	95	98,50	3,15	99,62	2,91	6,30							
DKL-98	98	101,50	3,15	102,71	2,91	6,30							
DKL-100	100	103,50	3,15	104,50	2,91	6,30							
DKL-102	102	106,00	4,15	107,27	3,89	6,73							
DKL-105	105	109,00	4,15	109,96	3,89	6,73							
DKL-108	108	112,00	4,15	113,09	3,89	6,73							
DKL-110	110	114,00	4,15	115,10	3,89	6,73							
DKL-112	112	116,00	4,15	117,12	3,89	6,73							
DKL-115	115	119,00	4,15	120,15	3,89	6,73							
DKL-120	120	124,00	4,15	125,60	3,89	6,73							
DKL-125	125	129,00	4,15	130,25	3,89	6,73							
DKL-127	127	131,00	4,15	132,27	3,89	6,73							
DKL-130	130	134,00	4,15	135,30	3,89	6,73							
DKL-135	135	139,00	4,15	140,35	3,89	6,73							
DKL-140	140	144,00	4,15	145,26	3,89	6,73							
DKL-145	145	149,00	4,15	150,45	3,89	6,73							
DKL-150	150	155,00	4,15	156,50	3,89	8,03							
DKL-155	155	160,00	4,15	161,55	3,89	8,03							
DKL-160	160	165,00	4,15	166,60	3,89	8,03							
DKL-165	165	170,00	4,15	171,70	3,89	8,03							
DKL-170	170	175,00	4,15	176,70	3,89	8,03							
DKL-175	175	180,00	4,15	181,75	3,89	8,03							
DKL-180	180	185,00	4,15	186,80	3,89	8,03							
DKL-185	185	190,00	4,15	191,85	3,89	8,03							
DKL-190	190	195,00	4,15	197,15	3,89	8,03							
DKL-195	195	200,00	4,15	201,95	3,89	8,03							
DKL-200	200	205,00	4,15	207,00	3,89	8,03							
DKL-210	210	216,00	5,15	217,93	4,87	9,48							
DKL-220	220	226,00	5,15	228,20	4,87	9,48							
DKL-230	230	236,00	5,15	238,30	4,87	9,48							
DKL-240	240	246,00	5,15	248,40	4,87	9,48							
DKL-250	250	256,00	5,15	258,50	4,87	9,48							
DKL-260	260	268,00	5,15	270,77	4,87	11,05							
DKL-270	270	278,00	5,15	280,70	4,87	11,05							
DKL-280	280	288,00	5,15	290,57	4,87	11,05							
DKL-290	290	298,00	5,15	300,90	4,87	11,05							
DKL-300	300	308,00	5,15	311,00	4,87	11,05							

# DCL Spiral Housing Rings

## DIN 471 Groove

### External, Heavy Duty, Metric

These snap rings are ideal for applications with high thrust loads and are designed to fit into a groove established by DIN specifications.

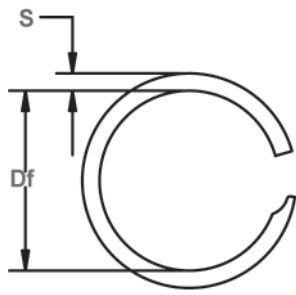

Free Diameter & Ring Measurements

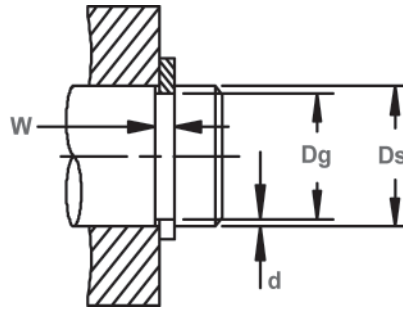

Shaft Diameter & Groove Dimensions

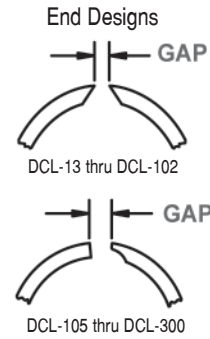

DCL-105 thru DCL-300

RING NO.	SHAFT DIAMETER (mm)	GROOVE SIZE				RING SIZE				SECTION		THRUST LOAD (N)		R.P.M. LIMITS Standard Material (Carbon Steel)
		DIAMETER		WIDTH		FREE DIAMETER		THICKNESS		S	Tol.	RING Safety factor of 3	GROOVE Safety factor of 2	
		Dg	Tol.	W	Tol.	Df	Tol.	T	Tol.					
DCL-13	13	12,4		1,10		12,27		0,94		1,40		10591	1931	31185
DCL-14	14	13,4		1,10		13,31		0,94		1,40		11396	2077	21602
DCL-15	15	14,3	+0,00	1,10		14,15		0,94		1,40		12224	2602	24273
DCL-16	16	15,2	-0,11	1,10		14,98		0,94		1,65		13029	3172	29110
DCL-17	17	16,2		1,10		16,06		0,94		1,65		13838	3367	19841
DCL-18	18	17,0		1,30		16,82		1,15		1,90		17953	4457	22605
DCL-19	19	18,0		1,30		17,81	+0,00	1,15		1,90		18941	4702	20417
DCL-20	20	19,0		1,30		18,80	-0,33	1,15		1,90		19928	4951	18532
DCL-21	21	20,0	+0,00	1,30		19,79		1,15		1,90		20942	5200	16896
DCL-22	22	21,0	-0,13	1,30		20,83		1,15		1,90		21930	5445	13523
DCL-23	23	22,0		1,30		21,77		1,15		1,90		22939	5698	14213
DCL-24	24	22,9		1,30		22,50		1,15		2,15		23927	6539	19083
DCL-25	25	23,9		1,30		23,70		1,15		2,15		24914	6806	11982
DCL-26	26	24,9	+0,00	1,30		24,64		1,15	±0,05	2,15	±0,10	25929	7082	12494
DCL-27	27	25,9	-0,21	1,30		25,50		1,15		2,15		26916	7353	14320
DCL-28	28	26,6		1,60		26,32		1,44		3,25		33179	9702	15229
DCL-29	29	27,6		1,60		27,15		1,44		3,25		34385	10053	18016
DCL-30	30	28,6		1,60	+0,14	28,35		1,44		3,25		35559	10395	12189
DCL-32	32	30,3		1,60	-0,00	29,87	+0,00	1,44		3,25		37939	13073	14215
DCL-33	33	31,3		1,60		31,07	-0,38	1,44		3,25		39113	13478	9511
DCL-34	34	32,3		1,60		31,96		1,44		3,25		40319	13892	10847
DCL-35	35	33,0		1,60		32,57		1,44		3,25		41493	16899	11685
DCL-36	36	34,0		1,85		33,64		1,69		4,01		50038	17375	11640
DCL-38	38	36,0	+0,00	1,85		35,62		1,69		4,01		52827	18344	10520
DCL-40	40	37,5	-0,25	1,85		37,02		1,69		4,01		55621	24265	10841
DCL-42	42	39,5		1,85		39,08		1,69		4,01		58410	25484	8972
DCL-45	45	42,5		1,85		42,05	+0,00	1,69		4,01		62578	27303	7861
DCL-46	46	43,5		1,85		43,10	-0,51	1,69		4,01		63952	27904	7006
DCL-47	47	44,5		1,85		44,03		1,69		4,01		65331	28504	7232
DCL-48	48	45,5		1,85		44,89		1,69		4,01		66741	29118	7881
DCL-50	50	47,0		2,15		46,50		1,93		5,08		75282	36529	7885
DCL-52	52	49,0		2,15		48,48		1,93		5,08		78266	37974	7318
DCL-54	54	51,0		2,15		50,46		1,93		5,08		81287	39438	6811
DCL-55	55	52,0		2,15		51,45		1,93		5,08		82777	40163	6576
DCL-56	56	53,0		2,15		52,44	+0,00	1,93		5,08		84307	40906	6354
DCL-58	58	55,0		2,15		54,42	-0,63	1,93		5,08		87287	42352	5942
DCL-60	60	57,0		2,15		56,55		1,93		5,08		90308	43819	4793
DCL-62	62	59,0	+0,00	2,15		58,32		1,93	±0,08	5,08	±0,13	93328	45283	5490
DCL-63	63	60,0	-0,30	2,15		59,37		1,93		5,08		94823	46008	5071
DCL-65	65	62,0		2,65		61,35		2,41		5,08		116641	47471	4806
DCL-67	67	64,0		2,65		63,35		2,41		5,08		120240	48939	4463
DCL-68	68	65,0		2,65		64,45	+0,00	2,41		5,08		122019	49660	3945
DCL-70	70	67,0		2,65		66,22	-0,76	2,41		5,08		125618	51128	4411
DCL-72	72	69,0		2,65		68,62		2,41		5,08		129221	52591	3947

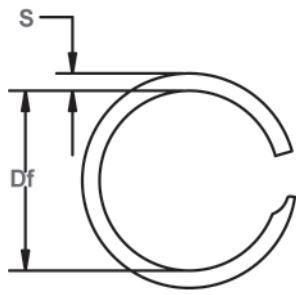

Free Diameter & Ring Measurements

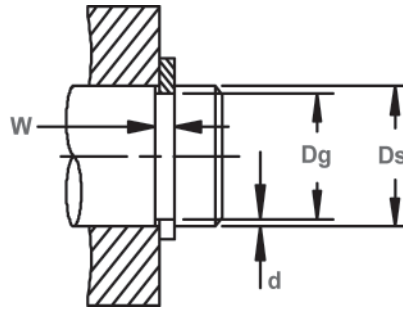

Shaft Diameter & Groove Dimensions

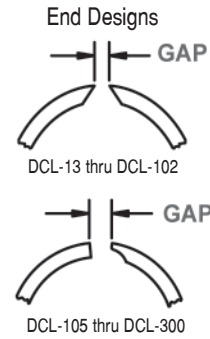

DCL-105 thru DCL-300

RING NO.	SHAFT DIAMETER (mm)	GROOVE SIZE				FREE DIAMETER		RING SIZE THICKNESS		SECTION		THRUST LOAD (N)		R.P.M. LIMITS Standard Material (Carbon Steel)
		DIAMETER		WIDTH								RING Safety factor of 3	GROOVE Safety factor of 2	
		Ds	Dg	Tol.	W	Tol.	Df	Tol.	T	Tol.	S	Tol.		
DCL-75	75	72,0		2,65		71,25		2,41		5,08		134599	54780	3648
DCL-77	77	74,0	+0,00	2,65	+0,14	73,23		2,41		5,08		138153	56230	3467
DCL-78	78	75,0	-0,30	2,65	-0,00	74,06	+0,00	2,41		5,08		139977	56968	3731
DCL-80	80	76,50		2,65		75,70	-0,76	2,41		6,02		143575	68342	3747
DCL-82	82	78,50		2,65		77,68		2,41		6,02		147134	70033	3574
DCL-85	85	81,50		3,15		80,65		2,91	±0,08	6,30		175656	72595	3476
DCL-88	88	84,50		3,15		83,60		2,91		6,30		181906	75175	3252
DCL-90	90	86,50	+0,00	3,15		85,80	+0,00	2,91		6,30		185998	76865	2731
DCL-95	95	91,50	-0,35	3,15		90,68	-0,89	2,91		6,30		196340	81140	2598
DCL-98	98	94,50		3,15		93,70		2,91		6,30		202536	83702	2377
DCL-100	100	96,50		3,15		95,50		2,91		6,30		206682	85415	2542
DCL-102	102	98,50		3,15		97,23		2,91		6,30	±0,13	210828	87127	2746
DCL-105	105	100,00		4,15		99,83		3,89		6,73		276951	102687	2640
DCL-108	108	104,00	+0,00	4,15		102,87		3,89		6,73		284855	105619	2418
DCL-110	110	106,00	-0,54	4,15		104,90		3,89		6,73		290149	107580	2279
DCL-115	115	111,00		4,15		109,85	+0,00	3,89		6,73		303346	112473	2090
DCL-120	120	116,00		4,15		115,06	-1,30	3,89		6,73		316478	117344	1694
DCL-125	125	121,00		4,15		119,75		3,89		6,73		329676	122237	1778
DCL-130	130	126,00		4,15		124,70		3,89		6,73		342873	127130	1647
DCL-135	135	131,00		4,15		129,65		3,89		6,73		356071	132023	1530
DCL-140	140	136,00		4,15		134,42		3,89		6,73		369269	136916	1519
DCL-145	145	141,00		4,15		139,55		3,89	±0,10	6,73		382467	141809	1331
DCL-150	150	145,00	+0,00	4,15	+0,18	143,50		3,89		8,03		395665	181986	1470
DCL-155	155	150,00	-0,63	4,15	-0,00	148,45		3,89		8,03		408796	188026	1379
DCL-160	160	155,00		4,15		153,40	+0,00	3,89		8,03		421994	194094	1296
DCL-165	165	160,00		4,15		158,40	-1,52	3,89		8,03		435192	200166	1201
DCL-170	170	165,00		4,15		163,30		3,89		8,03		448683	206237	1151
DCL-175	175	170,00		4,15		168,25		3,89		8,03	±0,15	461890	212305	1088
DCL-180	180	175,00		4,15		173,20		3,89		8,03		475097	218377	1030
DCL-185	185	180,00		4,15		177,62		3,89		8,03		488232	224417	1115
DCL-190	190	185,00		4,15		183,35		3,89		8,03		501439	230489	860
DCL-195	195	190,00		4,15		188,05		3,89		8,03		514646	236556	880
DCL-200	200	195,00		4,15		193,00	+0,00	3,89		8,03		527853	242628	837
DCL-205	205	199,00	+0,00	5,15		196,95	-1,78	4,87		11,05		641438	299454	1068
DCL-210	210	204,00	-0,72	5,15		201,67		4,87		11,05		657096	306763	1077
DCL-220	220	214,00		5,15		211,80		4,87		11,05		688327	321344	932
DCL-230	230	224,00		5,15		221,70		4,87		11,05		719638	335961	854
DCL-240	240	234,00		5,15		231,89		4,87		11,05		750953	350578	735
DCL-250	250	244,00		5,15		241,50		4,87	±0,13	11,05	±0,18	782264	365199	726
DCL-260	260	252,00		5,15		249,59		4,87		12,70		813500	505300	743
DCL-270	270	262,00	+0,00	5,15		259,30	+0,00	4,87		12,70		844811	524748	718
DCL-280	280	272,00	-0,81	5,15		268,83	-2,30	4,87		12,70		876126	544200	714
DCL-290	290	282,00		5,15		279,10		4,87		12,70		907357	563599	624
DCL-300	300	292,00		5,15		289,00		4,87		12,70		938673	583051	584

# KLM Spiral Housing Rings

Internal, Light-Duty, Metric

These single-turn snap rings are ideal for light duty applications.

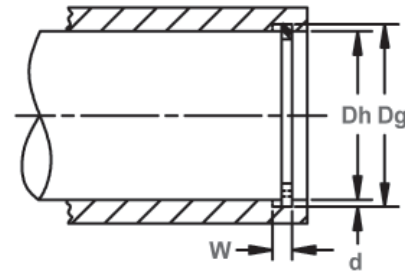
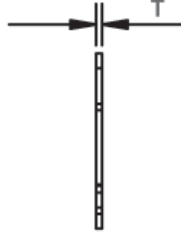
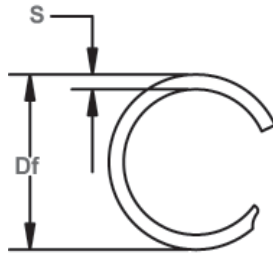

Free Diameter & Ring Measurements

Housing Diameter & Groove Dimensions

RING NO.	HOUSING DIAMETER (mm)		GROOVE SIZE				RING SIZE				THRUST LOAD (kN)			
			DIAMETER		WIDTH		FREE DIAMETER		THICKNESS		SECTION		RING Safety factor of 3	GROOVE Safety factor of 2
			Dh	Dg	Tol.	W	Tol.	Df	Tol.	T	Tol.	S		
KLM-6*	6	6.30		0.38		6.35		0.30		0.51		1.99	0.44	
KLM-7*	7	7.32		0.38		7.38	+0.25	0.30		0.51		2.32	0.55	
KLM-8*	8	8.36		0.46		8.44	-0.00	0.38		0.64		3.18	0.70	
KLM-9*	9	9.46		0.46		9.54		0.38		0.76		3.58	1.00	
KLM-10*	10	10.50		0.46		10.58	+0.30	0.38		0.76		3.98	1.24	
KLM-11	11	11.60		0.46		11.68	-0.00	0.38		0.89		4.39	1.63	
KLM-12	12	12.66	±0.05	0.46		12.74		0.38		0.89		4.77	1.93	
KLM-13	13	13.72		0.56		13.80		0.46		1.14		6.26	2.28	
KLM-14	14	14.72		0.56		14.80		0.46		1.14		6.74	2.46	
KLM-15	15	15.72		0.56		15.80		0.46		1.14		7.22	2.63	
KLM-16	16	16.72		0.56		16.80		0.46		1.14		7.71	2.81	
KLM-17	17	17.72		0.56	+0.05	17.82		0.46	±0.04	1.14		8.19	2.98	
KLM-18	18	18.72		0.56	-0.00	18.82	+0.33	0.46		1.14		8.67	3.16	
KLM-19	19	19.76		0.56		19.86	-0.00	0.46		1.14		9.15	3.52	
KLM-20	20	21.06		0.66		21.26		0.53		1.65		11.10	5.17	
KLM-21	21	22.06		0.66		22.27		0.53		1.65		11.65	5.42	
KLM-22	22	23.06	±0.08	0.66		23.28		0.53		1.65		12.21	5.68	
KLM-24	24	25.06		0.66		25.29		0.53		1.65		13.32	6.20	
KLM-25	25	26.06		0.66		26.30		0.53		1.65		13.87	6.46	
KLM-26	26	27.06		0.66		27.31		0.53		1.65		14.43	6.72	
KLM-28	28	29.12		0.79		29.40		0.64		2.24	±0.10	16.30	7.64	
KLM-29	29	30.12		0.79		30.41		0.64		2.24		16.88	7.91	
KLM-30	30	31.12		0.79		31.42		0.64		2.24		17.47	8.19	
KLM-31	31	32.12	±0.10	0.79		32.43	+0.38	0.64		2.24		18.05	8.46	
KLM-32	32	33.12		0.79		33.44	-0.00	0.64		2.24		18.63	8.73	
KLM-34	34	35.12		0.79		35.45		0.64		2.24		19.80	9.28	
KLM-35	35	36.12		0.79		36.47		0.64		2.24		20.38	9.55	
KLM-36	36	37.12		0.79		37.48		0.64		2.24		20.96	9.83	
KLM-37	37	38.12		0.79		38.49		0.64		2.24		21.54	10.10	
KLM-38	38	39.12		0.79		39.50		0.64		2.24		22.12	10.37	
KLM-40	40	41.48		0.99		41.94		0.79		3.00		28.75	14.43	
KLM-42	42	43.48		0.99		43.96		0.79		3.00		30.19	15.15	
KLM-45	45	46.48		0.99		46.99	+0.51	0.79		3.00		32.34	16.23	
KLM-47	47	48.48	±0.13	0.99		49.00	-0.00	0.79		3.00		33.78	16.95	
KLM-48	48	49.48		0.99		50.01		0.79		3.00		34.50	17.31	
KLM-50	50	51.48		0.99	+0.08	52.04		0.79	±0.05	3.00		35.93	18.03	
KLM-52	52	53.94		0.99	-0.00	54.55		0.79		4.01		37.37	24.58	
KLM-55	55	56.94		0.99		57.57		0.79		4.01		39.53	26.00	
KLM-56	56	57.94		0.99		58.58		0.79		4.01		40.25	26.47	
KLM-58	58	59.94		0.99		60.60	+0.64	0.79		4.01		41.68	27.42	
KLM-60	60	61.94	±0.15	0.99		62.64	-0.00	0.79		4.01		43.12	28.36	
KLM-62	62	63.94		0.99		64.67		0.79		4.01		44.56	29.31	
KLM-63	63	64.94		0.99		65.69		0.79		4.01		45.28	29.78	
KLM-65	65	66.94		0.99		67.70		0.79		4.01		46.72	30.73	

\* No Removal Notch.

ALL DIMENSIONS IN MILLIMETERS UNLESS OTHERWISE STATED.

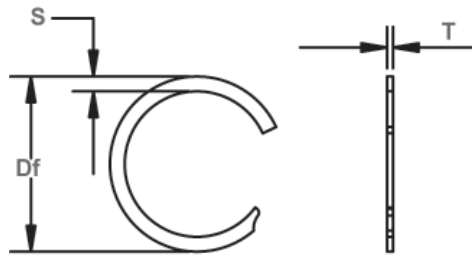

Free Diameter & Ring Measurements

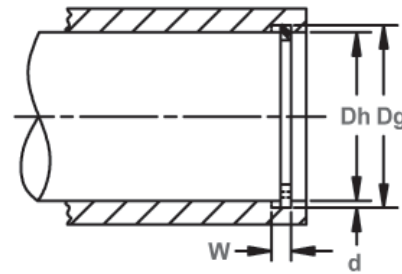

Housing Diameter & Groove Dimensions

RING NO.	HOUSING DIAMETER (mm)	GROOVE SIZE				RING SIZE				THRUST LOAD (kN)			
		DIAMETER		WIDTH		FREE DIAMETER		THICKNESS		SECTION		RING Safety factor of 3	GROOVE Safety factor of 2
		Dh	Dg	Tol.	W	Tol.	Df	Tol.	T	Tol.	S		
KLM-68	68	69.94	±0.15	0.99	+0.08 -0.00	70.72	+0.64 -0.00	0.79	±0.10	4.01	±0.10	48.87	32.15
KLM-70	70	71.94		0.99		72.74		0.79		4.01		50.31	33.09
KLM-72	72	73.94		0.99		74.77		0.79		4.01		51.75	34.04
KLM-75	75	76.94		0.99		77.80		0.79		4.01		53.90	35.46
KLM-78	78	80.34		1.12		81.20		0.99		4.78		70.25	44.48
KLM-80	80	82.34		1.12		83.23		0.99		4.78		72.05	45.62
KLM-82	82	84.34		1.12		85.25		0.99		4.78		73.85	46.76
KLM-85	85	87.34		1.12		88.29		0.99		4.78		76.55	48.47
KLM-88	88	90.34		1.12		91.32		0.99		4.78		79.26	50.18
KLM-90	90	92.34		1.12		93.36		0.99		4.78		81.06	51.32
KLM-92	92	94.34	1.12	95.37	0.99	4.78	82.86	52.46					
KLM-95	95	97.34	1.12	98.39	0.99	4.78	85.56	54.17					
KLM-98	98	100.34	1.12	101.41	0.99	4.78	88.26	55.88					
KLM-100	100	102.34	1.12	103.43	0.99	4.78	90.06	57.02					
KLM-102	102	104.34	1.12	105.44	0.99	4.78	91.87	58.16					
KLM-105	105	107.80	1.32	108.92	1.17	5.72	106.44	71.64					
KLM-110	110	112.80	1.32	113.98	1.17	5.72	111.51	75.05					
KLM-112	112	114.80	1.32	116.01	1.17	5.72	113.54	76.42					
KLM-115	115	117.88	1.32	119.12	1.17	5.72	116.58	80.71					
KLM-120	120	123.00	1.32	124.30	1.17	5.72	121.65	87.73					
KLM-125	125	128.12	1.32	129.47	1.17	5.72	126.71	95.04					
KLM-130	130	133.26	1.32	134.66	1.17	5.72	131.78	103.27					
KLM-135	135	138.38	1.70	139.83	1.55	5.72	181.30	111.19					
KLM-140	140	143.50	1.70	145.00	1.55	5.72	188.01	119.40					
KLM-150	150	153.76	1.70	155.30	1.55	6.73	201.44	137.44					
KLM-155	155	158.88	1.70	160.46	1.55	6.73	208.16	146.36					
KLM-160	160	164.00	1.70	165.64	1.55	6.73	214.87	155.96					
KLM-165	165	169.13	1.70	170.82	1.55	6.73	221.59	165.86					
KLM-170	170	174.25	1.70	175.99	1.55	6.73	228.30	176.06					
KLM-175	175	179.38	1.70	181.17	1.55	6.73	235.02	186.57					
KLM-180	180	184.50	1.70	186.35	1.55	6.73	241.73	197.38					
KLM-185	185	189.63	1.70	191.52	1.55	6.73	248.45	208.50					
KLM-190	190	194.75	1.70	196.70	1.55	6.73	255.16	219.92					
KLM-195	195	199.88	1.70	201.87	1.55	7.62	261.88	231.65					
KLM-200	200	205.00	1.70	207.05	1.55	7.62	268.59	243.68					
KLM-210	210	215.25	1.70	217.40	1.55	7.62	282.02	268.66					
KLM-220	220	225.50	2.08	227.76	1.93	8.76	367.88	294.85					
KLM-230	230	235.75	2.08	238.11	1.93	8.76	384.60	322.27					
KLM-240	240	246.00	2.08	248.46	1.93	8.76	401.33	350.90					
KLM-250	250	256.25	2.08	258.81	1.93	8.76	418.05	380.75					
KLM-260	260	266.50	2.08	269.17	1.93	9.65	434.77	411.82					
KLM-270	270	276.75	2.08	279.52	1.93	9.65	451.49	444.11					
KLM-280	280	287.00	2.08	289.87	1.93	9.65	468.21	477.61					
KLM-290	290	297.25	2.08	300.22	1.93	9.65	484.94	512.34					
KLM-300	300	307.50	2.08	310.58	1.93	9.65	501.66	548.28					

ALL DIMENSIONS IN MILLIMETERS UNLESS OTHERWISE STATED.

# CLM Spiral Shaft Rings

**External, Light-Duty, Metric**

These single-turn snap rings are ideal for light duty applications.

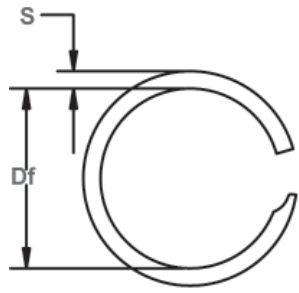

Free Diameter & Ring Measurements

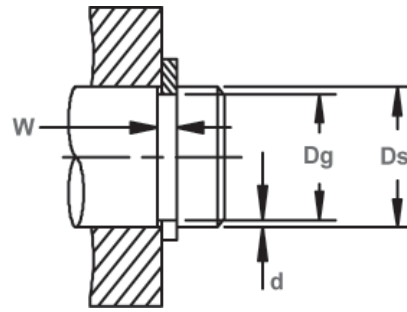

Shaft Diameter & Groove Dimensions

RING NO.	SHAFT DIAMETER (mm)	GROOVE SIZE				FREE DIAMETER		RING SIZE THICKNESS		SECTION		THRUST LOAD (kN)		R.P.M. LIMITS Standard Material (Carbon Steel)
		DIAMETER		WIDTH		Df	Tol.	T	Tol.	S	Tol.	RING Safety factor of 3	GROOVE Safety factor of 2	
		Ds	Dg	Tol.	W									
CLM-6*	6	5.70		0.38		5.65		0.30		0.51		1.99	0.44	51561
CLM-7*	7	6.64		0.38		6.58		0.30		0.51		2.23	0.61	39742
CLM-8*	8	7.60		0.46		7.52	+0.00	0.38		0.64		3.18	0.78	40518
CLM-9*	9	8.50		0.46		8.42	-0.25	0.38		0.76		3.58	1.11	35627
CLM-10*	10	9.40		0.46		9.32	+0.00	0.38		0.89		3.98	1.46	31833
CLM-11	11	10.40		0.46		10.32	-0.30	0.38		0.89		4.38	1.61	25202
CLM-12	12	11.34	±0.05	0.56		11.22		0.46		1.14		5.78	1.93	30875
CLM-13	13	12.28		0.56		12.15		0.46		1.14		6.26	2.28	26805
CLM-14	14	13.28		0.56	+0.05	13.15		0.46		1.14		6.74	2.46	22359
CLM-15	15	14.28		0.56	-0.00	14.14		0.46		1.14		7.22	2.63	19625
CLM-16	16	15.28		0.56		15.13		0.46		1.14		7.71	2.81	17364
CLM-17	17	16.28		0.56		16.13	+0.00	0.46	±0.04	1.14		8.19	2.98	14958
CLM-18	18	17.28		0.56		17.12	-0.33	0.46		1.14		8.67	3.16	13439
CLM-19	19	18.28		0.56		18.11		0.46		1.14		9.15	3.33	12140
CLM-20	20	19.28		0.56		19.10		0.46		1.14		9.63	3.51	11066
CLM-21	21	19.94		0.66		19.74		0.53		1.65		11.65	5.42	15326
CLM-22	22	20.94	±0.08	0.66		20.73		0.53		1.65		12.21	5.68	13341
CLM-24	24	22.94		0.66		22.72		0.53		1.65		13.32	6.20	11035
CLM-25	25	23.94		0.66		23.71		0.53		1.65	±0.10	13.87	6.46	10214
CLM-26	26	24.88		0.79		24.63		0.64		2.24		15.14	7.10	12483
CLM-28	28	26.88		0.79		26.62		0.64		2.24		16.30	7.64	10648
CLM-29	29	27.88		0.79		27.61		0.64		2.24		16.88	7.91	9973
CLM-30	30	28.88		0.79		28.59	+0.00	0.64		2.24		17.47	8.19	9534
CLM-32	32	30.88	±0.10	0.79		30.57	-0.38	0.64		2.24		18.63	8.73	8437
CLM-34	34	32.88		0.79		32.56		0.64		2.24		19.80	9.28	7398
CLM-35	35	33.88		0.79		33.55		0.64		2.24		20.38	9.55	7004
CLM-36	36	34.88		0.79		34.54		0.64		2.24		20.96	9.83	6641
CLM-38	38	36.88		0.79		36.52		0.64		2.24		22.12	10.37	5994
CLM-40	40	38.52		0.99	+0.08	38.09		0.79		3.00		28.75	14.43	7573
CLM-42	42	40.52	±0.13	0.99	-0.00	40.07	+0.00	0.79		3.00		30.19	15.15	6888
CLM-45	45	43.52		0.99		43.04	-0.51	0.79		3.00		32.34	16.23	6021
CLM-48	48	46.52		0.99		46.01		0.79		3.00		34.50	17.31	5309
CLM-50	50	48.52		0.99		47.99		0.79		3.00		35.93	18.03	4901
CLM-52	52	50.06		0.99		49.48		0.79		4.01		37.37	24.58	6057
CLM-55	55	53.06	±0.15	0.99		52.46		0.79	±0.05	4.01		39.53	26.00	5380
CLM-56	56	54.06		0.99		53.44		0.79		4.01		40.25	26.47	5238
CLM-58	58	56.06		0.99		55.42	+0.00	0.79		4.01		41.68	27.42	4890
CLM-60	60	58.06		0.99		57.40	-0.64	0.79		4.01		43.12	28.36	4575
CLM-62	62	60.06		0.99		59.37		0.79		4.01		44.56	29.31	4323
CLM-63	63	61.06		0.99		60.35		0.79		4.01		45.28	29.78	4220
CLM-65	65	63.06		0.99		62.33		0.79		4.01		46.72	30.73	3967

\* No Removal Notch.

ALL DIMENSIONS IN MILLIMETERS UNLESS OTHERWISE STATED.

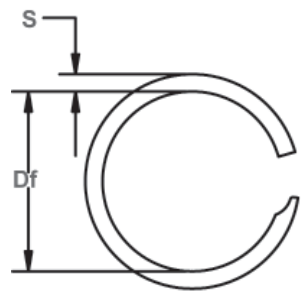

Free Diameter & Ring Measurements

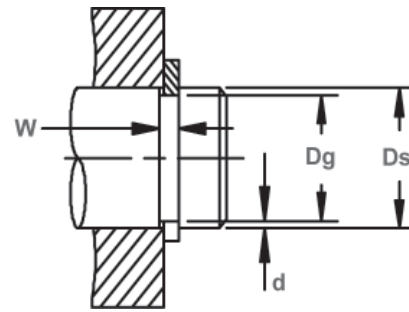
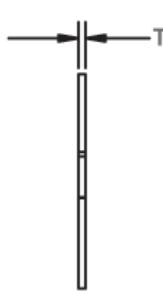

Shaft Diameter & Groove Dimensions

RING NO.	SHAFT DIAMETER (mm)	GROOVE SIZE				RING SIZE				SECTION		THRUST LOAD (kN)		R.P.M. LIMITS Standard Material (Carbon Steel)	
		DIAMETER		WIDTH		FREE DIAMETER		THICKNESS		S	Tol.	RING Safety factor of 3	GROOVE Safety factor of 2		
		Ds	Dg	Tol.	W	Tol.	Df	Tol.	T						Tol.
CLM-68	68	66.06	±0.15	0.99	+0.08 -0.00	65.31	+0.00	0.79	±0.05	4.01	±0.10	48.87	32.15	3602	
CLM-70	70	68.06		0.99		67.29		-0.64		0.79		4.01	50.31	33.09	3402
CLM-72	72	70.06		0.99		69.27		0.79		4.01		51.75	34.04	3218	
CLM-75	75	73.06		0.99		72.25	0.79	4.01		53.90		35.45	2949		
CLM-78	78	75.66		1.12		74.85	0.99	4.78		70.25		44.48	3158		
CLM-80	80	77.66		1.12		76.82	0.99	4.78		72.05		45.62	3025		
CLM-82	82	79.66		1.12		78.79	0.99	4.78		73.85		46.76	2900		
CLM-85	85	82.66		1.12		81.76	+0.00	4.78		76.55		48.47	2703		
CLM-88	88	85.66		1.12		84.73	-0.76	4.78		79.26		50.18	2526		
CLM-90	90	87.66		1.12		86.69	0.99	4.78		81.06		51.32	2443		
CLM-95	95	92.66	1.12	91.66	0.99	4.78	85.56	54.17	2174						
CLM-100	100	97.66	1.12	96.62	0.99	4.78	90.06	57.02	1955						
CLM-105	105	102.20	±0.18	1.32	+0.10 -0.00	101.13	+0.00	1.17	±0.13	5.72	±0.15	106.44	71.64	2082	
CLM-110	110	107.20		1.32		106.08		1.17		5.72		111.51	75.05	1902	
CLM-115	115	112.20		1.32		111.03		+0.00		5.72		116.58	78.47	1745	
CLM-120	120	117.20		1.32		115.98	-0.89	5.72		121.65		81.88	1606		
CLM-125	125	122.20		1.32		120.93	1.17	5.72		126.71		85.29	1483		
CLM-130	130	127.20		1.32		125.88	1.17	5.72		131.78		88.70	1374		
CLM-135	135	131.63		1.70		130.31	1.55	5.72		181.90		111.03	1270		
CLM-140	140	136.50		1.70		135.13	1.55	5.72		188.01		119.40	1186		
CLM-150	150	146.25		1.70		144.83	1.55	5.72		201.44		137.07	1022		
CLM-155	155	151.13		1.70		149.66	+0.00	5.72		208.16		146.36	961		
CLM-160	160	156.00	1.70	154.44	-1.14	5.72	214.87	155.96	1060						
CLM-165	165	160.88	1.70	159.27	1.55	6.73	221.59	165.86	1000						
CLM-170	170	165.75	1.70	164.09	1.55	6.73	228.30	176.06	945						
CLM-175	175	170.63	1.70	168.92	1.55	6.73	235.02	186.57	894						
CLM-180	180	175.50	1.70	173.75	1.55	6.73	241.73	197.38	848						
CLM-185	185	180.38	1.70	178.57	1.55	7.62	248.45	208.50	898						
CLM-190	190	185.25	1.70	183.40	1.55	7.62	255.16	219.92	854						
CLM-195	195	190.13	1.70	188.22	+0.00	7.62	261.88	231.65	813						
CLM-200	200	195.00	1.70	193.05	-1.52	7.62	268.59	243.68	775						
CLM-210	210	204.75	±0.20	2.08	+0.13 -0.00	202.70	+0.00	1.93	±0.15	8.76	±0.15	351.16	268.66	802	
CLM-220	220	214.50		2.08		212.36		1.93		8.76		367.88	294.85	734	
CLM-230	230	224.25		2.08		222.01		1.93		8.76		384.60	322.27	674	
CLM-240	240	234.00		2.08		231.66	1.93	8.76		401.33		350.90	622		
CLM-250	250	243.75		2.08		241.31	1.93	8.76		418.05		380.75	575		
CLM-260	260	253.50		2.08		250.97	+0.00	9.65		434.77		411.82	582		
CLM-270	270	263.25		2.08		260.62	-1.78	9.65		451.49		444.11	541		
CLM-280	280	273.00		2.08		270.27	1.93	9.65		468.21		477.61	505		
CLM-290	290	282.75		2.08		279.92	1.93	9.65		484.94		512.34	472		
CLM-300	300	292.50		2.08		289.58	1.93	9.65		501.66		548.28	443		

ALL DIMENSIONS IN MILLIMETERS UNLESS OTHERWISE STATED.



# MKM Spiral Housing Rings

## Internal, Medium Duty, Metric

These 2-turn rings provide 360° groove contact and are designed for applications with medium thrust loads.

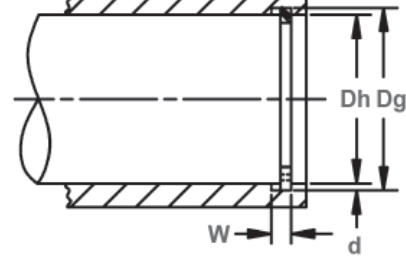
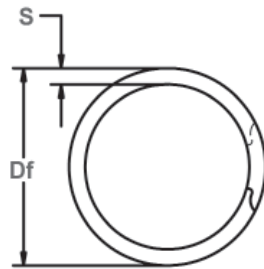

Free Diameter & Ring Measurements

Housing Diameter & Groove Dimensions

RING NO.	HOUSING DIAMETER (mm)	GROOVE SIZE				RING SIZE			THRUST LOAD (N)				
		DIAMETER		WIDTH		FREE DIAMETER		THICKNESS		SECTION			
		Dh	Dg	Tol.	W	Tol.	Df	Tol.	T	Tol.	S	Tol.	RING Safety factor of 3
MKM-12	12	12.66		0.75		12.78		0.64		1.14		8484	1591
MKM-13	13	13.72		0.75		13.84		0.64		1.14		9191	2008
MKM-14	14	14.72	+0.00	0.75		14.85		0.64		1.14		9898	2311
MKM-15	15	15.72	-0.10	0.75		15.85		0.64		1.14		10605	2621
MKM-16	16	16.72		0.75		16.85		0.64		1.14		11312	2953
MKM-17	17	17.72		0.75		17.85		0.64		1.14		12091	3308
MKM-18	18	18.72		0.75		18.85		0.64		1.14		12726	3685
MKM-19	19	19.86		0.91	+0.08	20.00	+0.33	0.80		1.65		15145	3627
MKM-20	20	20.86		0.91	-0.00	21.10	-0.00	0.80		1.65		15942	4196
MKM-21	21	21.86		0.91		22.04		0.80		1.65		16739	4444
MKM-22	22	23.00	+0.00	0.91		23.18		0.80		1.65		17536	5657
MKM-23	23	24.00	-0.15	0.91		24.19		0.80	+0.05	1.65		18333	6166
MKM-24	24	25.00		0.91		25.20		0.80	-0.05	1.65		19131	6697
MKM-25	25	26.26		1.07		26.45		0.94		1.90		23415	7653
MKM-26	26	27.26		1.07		27.50		0.94		1.90		24352	8376
MKM-28	28	29.26		1.07		29.50		0.94		1.90		26225	9596
MKM-29	29	30.26		1.07		30.50		0.94		1.90		27161	10242
MKM-30	30	31.32		1.22		31.55		1.10		2.16		32881	9817
MKM-32	32	33.32		1.22		33.57		1.10		2.16		35073	11131
MKM-33	33	34.32	+0.00	1.22		34.57		1.10		2.16		36169	11789
MKM-34	34	35.32	-0.20	1.22		35.57	+0.40	1.10		2.16		37265	12469
MKM-35	35	36.42		1.22		36.70	-0.00	1.10		2.40	+0.08	38361	14414
MKM-36	36	37.42		1.22		37.70		1.10		2.40	-0.13	39457	15194
MKM-37	37	38.42		1.22		38.70		1.10		2.40		40553	15997
MKM-38	38	39.42		1.22		39.70		1.10		2.40		41649	16824
MKM-39	39	40.60		1.42		40.90		1.25		2.75		44350	16130
MKM-40	40	41.60		1.42		41.90		1.25		2.75		45487	16904
MKM-41	41	42.60		1.42		42.92		1.25		2.75		46624	17780
MKM-42	42	43.60		1.42		43.93		1.25		2.75		47761	18636
MKM-43	43	44.72	+0.00	1.42		45.00		1.25		3.00		48899	20883
MKM-44	44	45.72	-0.25	1.42		46.02	+0.50	1.25		3.00		50036	21903
MKM-45	45	46.72		1.42		47.08	-0.00	1.25		3.00		51173	23143
MKM-47	47	48.80		1.42		49.18		1.25		3.00		53447	26412
MKM-48	48	49.80		1.42		50.18		1.25		3.00		54584	27474
MKM-50	50	51.92		1.42	+0.10	52.30		1.25		3.25		56859	31907
MKM-52	52	53.92		1.42	-0.00	54.30		1.25		3.25		59133	34360
MKM-53	53	54.92		1.42		55.32		1.25	+0.08	3.25		60270	35132
MKM-55	55	57.00		1.42		57.38		1.25	-0.08	3.50		62545	37976
MKM-56	56	58.00		1.42		58.40		1.25		3.50		63682	38667
MKM-58	58	60.00		1.42		60.43		1.25		3.50		65956	40048
MKM-59	59	61.08		1.42		61.54		1.25		3.50		67093	42368
MKM-60	60	62.14		1.42		62.57	+0.63	1.25		3.50		68231	44329
MKM-61	61	63.24	+0.00	1.42		63.65	-0.00	1.25		3.76		69368	47174
MKM-62	62	64.24	-0.30	1.42		64.70		1.25		3.76		70505	47947
MKM-63	63	65.24		1.42		65.70		1.25		3.76		71642	48720
MKM-64	64	66.34		1.42		66.77		1.25		3.76		72779	51703
MKM-65	65	67.34		1.42		67.82		1.25		3.76		73916	52511
MKM-66	66	68.34		1.42		68.80		1.25		3.76		75054	53319





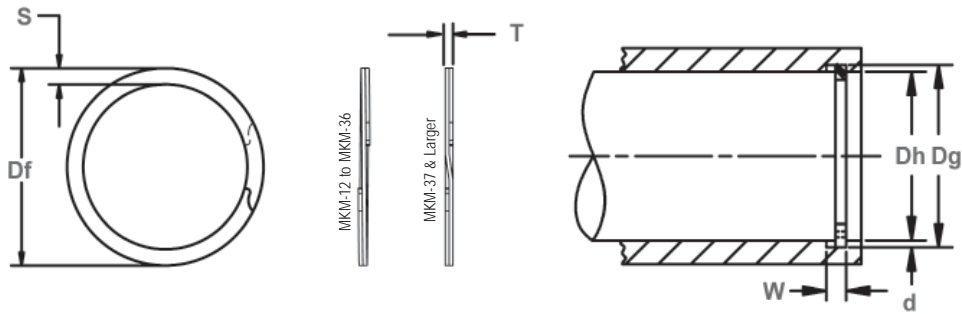

Free Diameter & Ring Measurements

Housing Diameter & Groove Dimensions

RING NO.	HOUSING DIAMETER (mm)	GROOVE SIZE				RING SIZE						THRUST LOAD (N)	
		DIAMETER		WIDTH		FREE DIAMETER		THICKNESS		SECTION		RING Safety factor of 3	GROOVE Safety factor of 2
		Dh	Dg	Tol.	W	Tol.	Df	Tol.	T	Tol.	S		
MKM-67	67	69.40	+0.00 -0.30	1.42	+0.10 -0.00	69.90	+0.63 -0.00	1.25	+0.08 -0.08	3.76	+0.08 -0.13	76191	55515
MKM-68	68	70.44		1.42		70.94		1.25		4.01		77328	57282
MKM-69	69	71.44		1.42		71.94		1.25		4.01		78465	58125
MKM-70	70	72.44		1.42		72.94		1.25		4.01		79602	58967
MKM-71	71	73.44		1.42		73.99		1.25		4.01		80740	59809
MKM-72	72	74.54		1.42		75.04		1.25		4.27		81877	63137
MKM-75	75	77.54		1.42		78.07		1.25		4.27		85288	65768
MKM-78	78	80.60		1.73		81.21		1.55		4.27		109988	70015
MKM-80	80	82.64		1.73		83.22		1.55		4.52		112808	72915
MKM-82	82	84.70		1.73		85.28		1.55		4.52		115628	76436
MKM-85	85	87.80	1.73	88.38	1.55	4.78	119858	82167					
MKM-88	88	90.84	1.73	91.45	1.55	4.78	124089	86282					
MKM-90	90	92.94	1.73	93.58	1.55	5.03	126909	91350					
MKM-92	92	95.00	1.73	95.66	1.55	5.03	129729	95286					
MKM-95	95	98.00	1.73	98.69	1.55	5.03	133959	98393					
MKM-98	98	101.14	1.73	101.83	1.55	5.28	138190	106237					
MKM-100	100	103.14	1.73	103.83	1.55	5.28	141010	108405					
MKM-102	102	105.30	1.73	106.00	1.55	5.54	143830	116208					
MKM-105	105	108.30	1.73	109.00	1.55	5.54	148060	119626					
MKM-108	108	111.46	1.73	112.22	1.55	5.80	152291	129009					
MKM-110	110	113.46	1.73	114.25	1.55	5.80	155111	131398					
MKM-112	112	115.60	1.73	116.44	1.55	6.05	157931	139201					
MKM-115	115	118.60	1.73	119.44	1.55	6.05	162161	142929					
MKM-120	120	123.70	2.00	124.54	1.83	6.35	199779	153286					
MKM-125	125	128.70	2.00	129.59	1.83	6.35	208103	159673					
MKM-130	130	133.80	2.00	134.71	1.83	6.35	216427	170548					
MKM-135	135	138.80	2.00	139.74	1.83	6.35	224752	177108					
MKM-140	140	143.90	2.00	144.87	1.83	6.35	233076	188501					
MKM-145	145	149.00	2.00	150.04	1.83	6.35	241400	200239					
MKM-150	150	154.00	2.00	155.07	1.83	6.35	249724	207144					
MKM-155	155	159.60	2.40	160.72	2.18	7.92	307401	246156					
MKM-160	160	164.60	2.40	165.74	2.18	7.92	317318	254096					
MKM-165	165	169.60	2.40	170.77	2.18	7.92	327234	262037					
MKM-170	170	174.80	2.40	176.05	2.18	7.92	337150	281716					
MKM-175	175	179.80	2.40	181.05	2.18	7.92	347066	290001					
MKM-180	180	185.08	2.40	186.38	2.18	7.92	356982	315687					
MKM-185	185	190.08	2.40	191.10	2.18	7.92	366899	324456					
MKM-190	190	195.08	2.40	196.45	2.18	7.92	376815	333225					
MKM-195	195	200.34	2.40	201.74	2.18	7.92	386731	359498					
MKM-200	200	205.34	2.40	206.76	2.18	7.92	396647	368716					
MKM-210	210	215.60	2.40	217.10	2.18	9.52	416479	406002					
MKM-220	220	225.84	2.40	227.40	2.18	9.52	436312	443564					
MKM-230	230	236.10	2.40	237.73	2.18	9.52	456144	484371					
MKM-240	240	246.10	2.40	247.80	2.18	9.52	475976	505431					
MKM-250	250	256.36	2.40	258.10	2.18	9.52	495809	548931					
MKM-260	260	266.60	2.40	268.43	2.18	9.52	515641	592431					
MKM-270	270	276.60	2.40	278.50	2.18	9.52	535474	615217					
MKM-280	280	286.86	2.40	288.82	2.18	9.52	555306	663136					

# MCM Spiral Shaft Rings

## External, Medium Duty, Metric

These 2-turn rings provide 360° groove contact and are designed for applications with medium thrust loads.

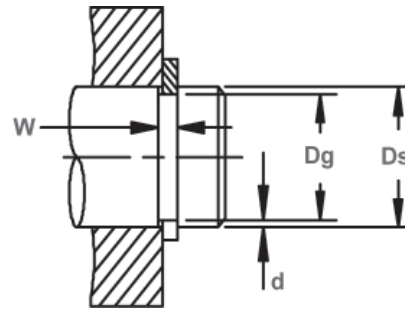
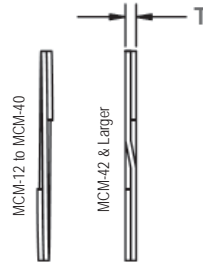
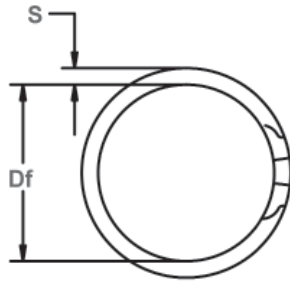

Free Diameter & Ring Measurements

Shaft Diameter & Groove Dimensions

RING NO.	SHAFT DIAMETER (mm)	GROOVE SIZE				RING SIZE				SECTION		THRUST LOAD (N)	
		DIAMETER		WIDTH		FREE DIAMETER		THICKNESS		S	Tol.	RING Safety factor of 3	GROOVE Safety factor of 2
		Dg	Tol.	W	Tol.	Df	Tol.	T	Tol.				
MCM-12	12	11.34		0.75		11.17		0.64		1.14		8484	2246
MCM-13	13	12.28		0.75		12.15		0.64		1.14		9191	2951
MCM-14	14	13.28		0.75		13.15		0.64		1.14		9898	3480
MCM-15	15	14.28		0.75		14.15		0.64		1.14		10605	3729
MCM-16	16	15.14		0.75		14.98		0.64		1.40		11312	4750
MCM-17	17	16.14		0.75		15.98		0.64		1.40		12091	5047
MCM-18	18	17.14	+ 0.10	0.75		16.98		0.64		1.40		12726	5344
MCM-19	19	18.14	-0.00	0.91	+ 0.08	17.98	+ 0.00	0.80		1.65		15145	5573
MCM-20	20	19.14		0.91	-0.00	18.98	-0.33	0.80		1.65		15942	5938
MCM-21	21	20.14		0.91		19.98		0.80		1.65		16739	6235
MCM-22	22	21.00		0.91		20.82		0.80	+0.05	1.65		17536	7595
MCM-23	23	22.00		0.91		21.82		0.80	-0.05	1.65		18333	7941
MCM-24	24	23.00		0.91		22.80		0.80		1.65		19131	8286
MCM-25	25	23.84		1.07		23.64		0.94		1.90		23415	10012
MCM-26	26	24.84	+ 0.13	1.07		24.61		0.94		1.90		24352	10412
MCM-27	27	25.84	-0.00	1.07		25.61		0.94		1.90		25288	10813
MCM-28	28	26.84		1.07		26.61		0.94		1.90		26225	11213
MCM-29	29	27.84		1.07		27.61		0.94		1.90		27161	11614
MCM-30	30	28.68		1.22		28.45		1.10		2.16		32881	13671
MCM-32	32	30.68		1.22		30.43	+ 0.00	1.10		2.16		35073	14583
MCM-33	33	31.68		1.22		31.42	-0.38	1.10		2.40		36169	15039
MCM-34	34	32.68	+ 0.20	1.22		32.43		1.10		2.40	+ 0.08	37265	15494
MCM-35	35	33.60	-0.00	1.22		33.32		1.10		2.40	-0.13	38361	16917
MCM-36	36	34.60		1.22		34.32		1.10		2.40		39457	17400
MCM-37	37	35.66		1.22		35.36		1.10		2.40		40553	17883
MCM-38	38	36.60		1.22		36.32		1.10		2.40		41649	18367
MCM-39	39	37.48		1.42		37.25		1.25		2.75		44350	20466
MCM-40	40	38.48		1.42		38.18		1.25		2.75		45487	20991
MCM-42	42	40.40		1.42	+ 0.10	40.10		1.25		2.75		47761	23200
MCM-43	43	41.38	+ 0.25	1.42	-0.00	41.04	+ 0.00	1.25		3.00		48899	24049
MCM-44	44	42.38	-0.00	1.42		42.06	-0.50	1.25		3.00		50036	24609
MCM-45	45	43.28		1.42		42.95		1.25		3.00		51173	26722
MCM-47	47	45.22		1.42		44.85		1.25		3.25		53447	29207
MCM-48	48	46.20		1.42		45.85		1.25	+ 0.08	3.25		54584	29829
MCM-50	50	48.20		1.42		47.82		1.25	-0.08	3.25		56859	31072
MCM-52	52	50.00		1.42		49.62		1.25		3.25		59133	35905
MCM-53	53	51.00		1.42		50.62		1.25		3.25		60270	36595
MCM-54	54	52.00		1.42		51.62		1.25		3.25		61408	37286
MCM-55	55	53.00		1.42		52.62		1.25		3.50		62545	37976
MCM-56	56	54.00	+ 0.30	1.42		53.62	+ 0.00	1.25		3.50		63682	38667
MCM-58	58	55.86	-0.00	1.42		55.43	-0.63	1.25		3.50		65956	42851
MCM-59	59	56.86		1.42		56.43		1.25		3.50		67093	43590
MCM-60	60	57.86		1.42		57.43		1.25		3.50		68231	44329
MCM-61	61	58.76		1.42		58.36		1.25		3.50		69368	47174
MCM-62	62	59.76		1.42		59.30		1.25		3.76		70505	47947

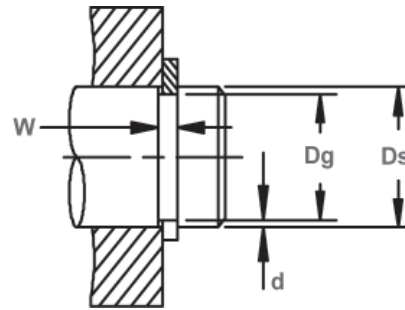
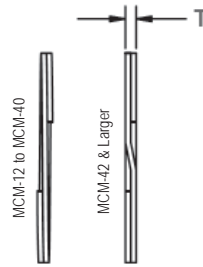
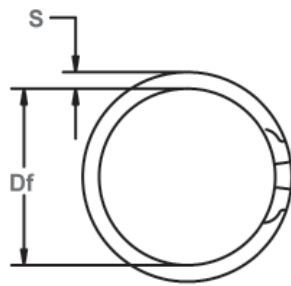

Free Diameter & Ring Measurements

Shaft Diameter & Groove Dimensions

RING NO.	SHAFT DIAMETER (mm)	GROOVE SIZE				FREE DIAMETER		RING SIZE THICKNESS		SECTION		THRUST LOAD (N)	
		DIAMETER		WIDTH		Df	Tol.	T	Tol.	S	Tol.	RING Safety factor of 3	GROOVE Safety factor of 2
		Dg	Tol.	W	Tol.								
MCM-63	63	60.76		1.42		60.30		1.25		3.76		71642	48720
MCM-64	64	61.76		1.42		61.25		1.25		3.76		72779	49494
MCM-65	65	62.66		1.42		62.20	+0.00	1.25		3.76		73916	50267
MCM-66	66	63.64		1.42		63.16	-0.63	1.25		3.76	+0.08	75054	53775
MCM-67	67	64.56		1.42	+0.10	64.16		1.25		3.76	-0.13	76191	56440
MCM-68	68	65.56		1.42	-0.00	65.08		1.25		4.00		77328	57282
MCM-69	69	66.56		1.42		66.06		1.25		4.00		78465	58125
MCM-70	70	67.56		1.42		67.08		1.25		4.00		79602	58967
MCM-71	71	68.56		1.42		68.04		1.25		4.00		80740	59809
MCM-72	72	69.50		1.42		69.00	+0.00	1.25	+0.08	4.27	-0.08	81877	62143
MCM-75	75	72.46	+0.30	1.42		71.93	-0.76	1.25	-0.08	4.27		85288	65768
MCM-78	78	75.40	-0.00	1.73		74.84		1.55		4.27		109988	70015
MCM-80	80	77.36		1.73		76.80		1.55		4.52		112808	72915
MCM-82	82	79.30		1.73		78.72		1.55		4.52		115628	76436
MCM-85	85	82.20		1.73		81.62		1.55		4.77		119858	82167
MCM-88	88	85.16		1.73		84.53		1.55		4.77		124089	86282
MCM-90	90	87.06		1.73		86.43		1.55		5.03		126909	91350
MCM-95	95	92.00		1.73		91.37		1.55		5.03		133959	98393
MCM-100	100	96.86		1.73		96.10	+0.00	1.55		5.28		141010	108405
MCM-105	105	101.70		1.73	+0.13	100.94	-1.00	1.55		5.53	+0.10	148060	119626
MCM-110	110	106.54		1.73	-0.00	105.75		1.55		5.80	-0.15	155111	131398
MCM-115	115	111.40		1.73		110.59		1.55		6.05		162161	142929
MCM-120	120	116.30		2.00		115.49		1.83		6.35		199779	153286
MCM-125	125	121.30		2.00		120.44		1.83		6.35		208103	159673
MCM-130	130	126.20		2.00		125.34		1.83		6.35		216427	170548
MCM-135	135	131.10		2.00		130.20		1.83		6.35		224752	181769
MCM-140	140	136.08	+0.35	2.00		135.14	+0.00	1.83		6.35		233076	189468
MCM-145	145	141.00	-0.00	2.00		140.00	-1.30	1.83		6.35		241400	200293
MCM-150	150	146.00		2.00		145.00		1.83		6.35		249724	207144
MCM-155	155	150.40		2.40		149.33		2.18		7.92		307401	246156
MCM-160	160	155.40		2.40		154.31		2.18		7.92		317318	254096
MCM-165	165	160.40		2.40		159.23	+0.00	2.18		7.92		327234	262037
MCM-170	170	165.20		2.40		164.00	-1.52	2.18	+0.10	7.92	-0.10	337150	281716
MCM-175	175	170.20		2.40		169.00		2.18	-0.10	7.92		347066	290001
MCM-180	180	175.00		2.40		173.78		2.18		7.92		356982	310716
MCM-185	185	180.00		2.40		178.70		2.18		7.92		366899	319347
MCM-190	190	185.00	+0.40	2.40	+0.15	183.70		2.18		7.92	+0.10	376815	327978
MCM-195	195	189.80	-0.00	2.40	-0.00	188.43		2.18		7.92	-0.20	386731	350073
MCM-200	200	194.80		2.40		193.43		2.18		7.92		396647	359049
MCM-210	210	204.40		2.40		202.93		2.18		9.52		416479	406002
MCM-220	220	214.20		2.40		212.65	+0.00	2.18		9.52		436312	440526
MCM-230	230	224.20		2.40		222.60	-1.78	2.18		9.52		456144	460550
MCM-240	240	234.00		2.40		232.32		2.18		9.52		475976	497145
MCM-250	250	243.60		2.40		241.83		2.18		9.52		495809	552383
MCM-260	260	253.40		2.40		251.57		2.18		9.52		515641	592431
MCM-270	270	263.20		2.40		261.30		2.18		9.52		535474	633806
MCM-280	280	273.00		2.40		271.04		2.18		9.52		555306	676670



# MKR Spiral Housing Rings

## Internal, Medium-Heavy Duty Metric

These 2-turn and multi-turn rings provide 360° groove contact and are designed for applications with medium-high thrust loads.

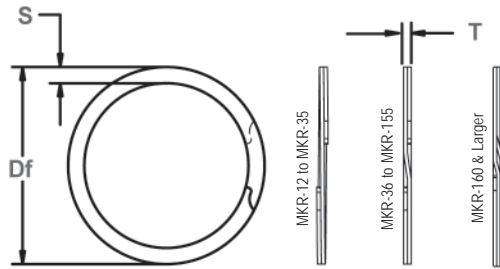

Free Diameter & Ring Measurements

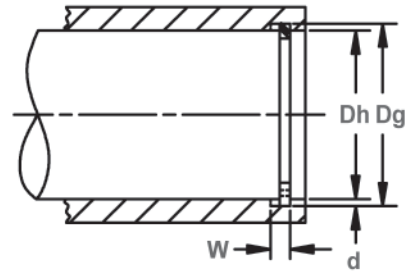

Housing Diameter & Groove Dimensions

RING NO.	HOUSING DIAMETER (mm)	GROOVE SIZE				RING SIZE						THRUST LOAD (N)	
		DIAMETER		WIDTH		FREE DIAMETER		THICKNESS		SECTION		RING Safety factor of 3	GROOVE Safety factor of 2
		Dh	Dg	Tol.	W	Tol.	Df	Tol.	T	Tol.	S		
MKR-12	12	12.60	+0.08 -0.08	1.00	+0.08 -0.00	12.73	+0.33 -0.00	0.89	+0.05 -0.05	1.14	+0.08 -0.13	10641	929
MKR-13	13	13.60		1.00		13.73		0.89		1.14		11528	1067
MKR-14	14	14.76		1.00		14.89		0.89		1.14		12415	1555
MKR-15	15	15.86		1.00		16.01		0.89		1.14		13302	2026
MKR-16	16	16.86		1.00		17.01		0.89		1.14		14188	2275
MKR-17	17	17.90		1.00		18.05		0.89		1.40		15075	2711
MKR-18	18	18.90		1.00		19.05		0.89		1.40		15962	3005
MKR-19	19	20.00		1.00		20.15		0.89		1.40		16849	3700
MKR-20	20	21.06		1.17		21.21		1.07		1.65		21323	3707
MKR-21	21	22.12		1.17		22.30		1.07		1.65		22389	4352
MKR-22	22	23.16	1.17	23.34	1.07	1.65	23455	4910					
MKR-23	23	24.22	1.17	24.50	1.07	1.65	24521	5831					
MKR-24	24	25.26	1.17	25.46	1.07	1.90	25587	6398					
MKR-25	25	26.40	1.17	26.60	1.07	1.90	26653	7693					
MKR-26	26	27.42	1.17	27.62	1.07	1.90	27719	8389					
MKR-28	28	29.48	+0.10 -0.10	1.42	+0.10 -0.00	29.71	+0.38 -0.00	1.27	+0.08 -0.08	1.98	+0.10 -0.15	32350	7734
MKR-29	29	30.52		1.42		30.77		1.27		1.98		33506	8531
MKR-30	30	31.56		1.42		31.81		1.27		2.24		34661	9422
MKR-32	32	33.80		1.42		34.05		1.27		2.50		36972	12416
MKR-33	33	34.84		1.42		35.12		1.27		2.50		38127	13561
MKR-34	34	35.88		1.42		36.16		1.27		2.50		39283	14638
MKR-35	35	36.90		1.42		37.18		1.27		2.50		40438	15603
MKR-36	36	37.90		1.42		38.18		1.27		2.50		41593	16429
MKR-37	37	39.00		1.42		39.28		1.27		2.75		42749	18368
MKR-38	38	40.00		1.42		40.28		1.27		2.75		43904	19289
MKR-39	39	41.06	1.42	41.37	1.27	2.75	45059	21028					
MKR-40	40	42.14	+0.13 -0.13	1.73	+0.10 -0.00	42.44	+0.50 -0.00	1.57	+0.08 -0.08	3.00	+0.10 -0.15	57132	18286
MKR-41	41	43.24		1.73		43.54		1.57		3.00		58560	20065
MKR-42	42	44.34		1.73		44.64		1.57		3.00		59988	21951
MKR-43	43	45.36		1.73		45.69		1.57		3.00		61417	23283
MKR-44	44	46.38		1.73		46.81		1.57		3.00		62845	25023
MKR-45	45	47.40		1.73		47.73		1.57		3.00		64273	25764
MKR-47	47	49.54		1.73		49.84		1.57		3.25		67130	29617
MKR-48	48	50.54		1.73		50.90		1.57		3.25		68558	31168
MKR-50	50	52.64		1.73		53.00		1.57		3.50		71415	35192
MKR-52	52	54.84		2.18		55.22		1.98		3.58		93667	32153
MKR-53	53	55.88	2.18	56.26	1.98	3.58	95468	33791					
MKR-55	55	57.94	2.18	58.34	1.98	3.58	99071	37098					
MKR-56	56	58.94	2.18	59.34	1.98	3.58	100872	38358					
MKR-58	58	61.20	2.18	61.63	1.98	4.77	104475	49567					
MKR-59	59	62.22	2.18	62.65	1.98	4.77	106276	47432					
MKR-60	60	63.30	2.18	63.73	1.98	4.77	108077	50494					
MKR-61	61	64.30	2.18	64.76	1.98	4.77	109879	52323					
MKR-62	62	65.36	2.18	65.82	1.98	4.77	111680	54926					
MKR-63	63	66.40	2.18	66.86	1.98	4.77	113481	57265					
MKR-64	64	67.40	2.18	67.90	1.98	4.77	115282	59331					
MKR-65	65	68.50	2.62	69.00	2.36	4.77	132909	50522					
MKR-66	66	69.50	2.62	70.03	2.36	4.77	134954	52189					



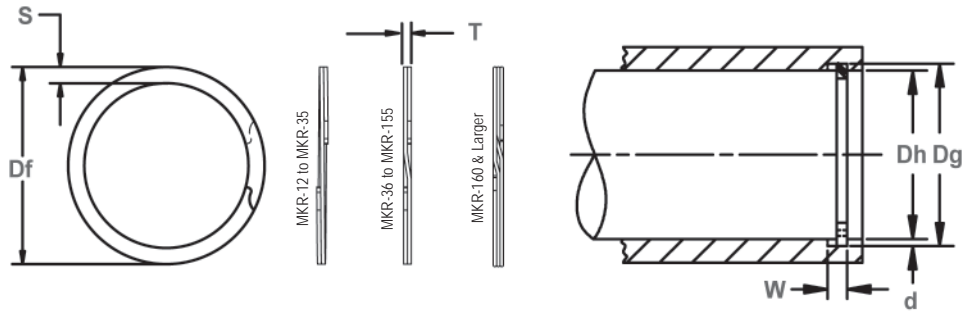

Free Diameter & Ring Measurements

Housing Diameter & Groove Dimensions

RING NO.	HOUSING DIAMETER (mm)	GROOVE SIZE				RING SIZE						THRUST LOAD (N)	
		DIAMETER		WIDTH		FREE DIAMETER		THICKNESS		SECTION		RING Safety factor of 3	GROOVE Safety factor of 2
		Dh	Dg	Tol.	W	Tol.	Df	Tol.	T	Tol.	S		
MKR-67	67	70.60		2.62		71.13		2.36		4.77		136998	55235
MKR-68	68	71.66		2.62		72.19		2.36		4.77		139043	57735
MKR-69	69	72.74		2.62		73.27	+0.63	2.36		4.77		141088	60650
MKR-70	70	73.80		2.62		74.33	-0.00	2.36		4.77		143133	63315
MKR-71	71	74.80		2.62		75.36		2.36		4.77		145177	65251
MKR-72	72	75.86		2.62		76.42		2.36		4.77		147222	68052
MKR-75	75	79.00		2.62		79.58		2.36		4.77		153356	76340
MKR-78	78	82.26		3.05		82.95		2.82		6.35	+0.10	190578	75542
MKR-80	80	84.36		3.30		85.02		2.82		6.35	-0.15	195464	80623
MKR-82	82	86.40		3.05		87.06		2.82		6.35		200351	85092
MKR-85	85	89.58	+0.15	3.05	+0.13	90.21		2.82	+0.08	6.35		207681	94335
MKR-88	88	92.78	-0.15	3.05	-0.00	93.44	+0.76	2.82	-0.08	6.35		215011	105482
MKR-90	90	94.88		3.05		95.54	-0.00	2.82		6.35		219897	112323
MKR-92	92	97.00		3.05		97.68		2.82		6.35		224784	120232
MKR-95	95	100.20		3.05		100.88		2.82		6.35		232114	132913
MKR-98	98	103.40		3.05		104.11		2.82		6.35		239444	146909
MKR-100	100	105.40		3.05		106.11		2.82		6.35		244330	152534
MKR-102	102	107.60		3.05		108.31		2.82		6.35		249217	164421
MKR-105	105	110.60		3.05		111.34		2.82		7.92		256547	176970
MKR-108	108	113.60		3.05		114.36		2.82		7.92		263877	186814
MKR-110	110	115.74		3.05		116.50		2.82		7.92		268763	198334
MKR-112	112	117.84		3.05		118.60	+0.90	2.82		7.92		273650	208838
MKR-115	115	121.00		3.05		121.83	-0.00	2.82		7.92		280980	227125
MKR-120	120	126.20		3.05		127.04		2.82		7.92		293197	254750
MKR-125	125	131.50		3.05		132.39		2.82		7.92		305413	280507
MKR-130	130	136.70		3.05		137.61		2.82		7.92		317630	300704
MKR-135	135	141.90		3.53		142.90		3.23		9.52		377802	314888
MKR-140	140	146.90	+0.18	3.53	+0.15	147.91	+1.14	3.23	+0.10	9.52		391795	333502
MKR-145	145	151.90	-0.18	3.53	-0.00	152.97	-0.00	3.23	-0.10	9.52		405788	345412
MKR-150	150	156.90		3.53		158.02		3.23		9.52	+0.10	419780	357323
MKR-155	155	161.90		3.53		163.04		3.23		9.52	-0.20	433773	369234
MKR-160	160	167.10		4.42		168.27		4.20		7.92		582234	392192
MKR-165	165	172.36		4.42		173.55	+1.40	4.20		7.92		600429	419259
MKR-170	170	177.70		4.42		178.94	-0.00	4.20		7.92		618624	451919
MKR-175	175	182.80		4.42		184.09		4.20		7.92		636819	471252
MKR-180	180	188.00		4.42		189.30		4.20		7.92		655014	497145
MKR-185	185	193.24	+0.20	5.30	+0.20	194.59		4.80	+0.13	9.52		769381	526283
MKR-190	190	198.64	-0.20	5.30	-0.00	200.04		4.80	-0.13	9.52		790175	566745
MKR-195	195	203.74		5.30		205.14		4.80		9.52		810969	588392
MKR-200	200	208.90		5.30		210.37		4.80		9.52		831763	614527
MKR-210	210	219.40		5.30		220.92	+1.78	4.80		9.52		873351	681503
MKR-220	220	229.90		5.30		231.52	-0.00	4.80		9.52		914940	751932
MKR-230	230	240.20		5.30		241.90		4.80		9.52		956528	809932
MKR-240	240	250.90		5.30		252.65		4.80		9.52		998116	903147
MKR-250	250	260.90		5.30		262.70		4.80		9.52		1039704	940778
MKR-260	260	271.40		5.30		273.20		4.80		9.52		1081292	1023290
MKR-270	270	281.40		5.30		283.20		4.80		9.52		1122880	1062648
MKR-280	280	291.40		5.30		293.30		4.80		9.52		1164468	1102005

# MCR Spiral Shaft Rings

## External, Medium-Heavy Duty, Metric

These 2-turn and multi-turn rings provide 360° groove contact and are designed for applications with medium-high thrust loads.

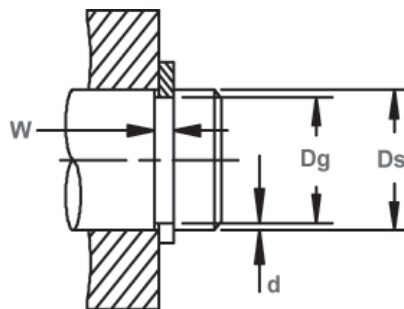
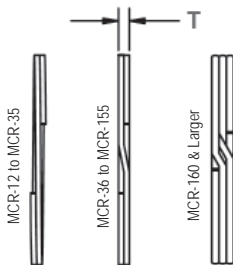
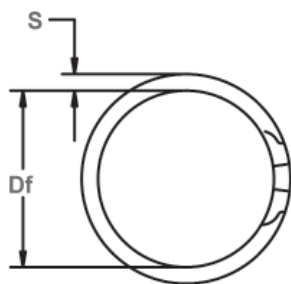

Free Diameter & Ring Measurements

Shaft Diameter & Groove Dimensions

RING NO.	SHAFT DIAMETER (mm)	GROOVE SIZE				FREE DIAMETER		RING SIZE THICKNESS		SECTION		THRUST LOAD (N)		
		Ds	Dg	Tol.	W	Tol.	Df	Tol.	T	Tol.	S	Tol.	RING Safety factor of 3	GROOVE Safety factor of 2
MCR-12	12	11.34		1.00		11.21		0.89		1.14		10641	1384	
MCR-13	13	12.34		1.00		12.21		0.89		1.14		11528	1678	
MCR-14	14	13.30		1.00		13.15		0.89		1.14		12415	2069	
MCR-15	15	14.28		1.00		14.13		0.89		1.14		13302	2499	
MCR-16	16	15.28		1.00		15.13		0.89		1.40		14188	2837	
MCR-17	17	16.20		1.00		16.05		0.89		1.40		15075	3609	
MCR-18	18	17.14		1.17		16.96		1.07		1.65		19190	3571	
MCR-19	19	18.12	+0.08	1.17	+0.08	17.94	+0.00	1.07		1.65		20256	4148	
MCR-20	20	19.08	-0.08	1.17	-0.00	18.90	-0.33	1.07		1.65		21323	4878	
MCR-21	21	20.08		1.17		19.88		1.07		1.65		22389	5397	
MCR-22	22	20.94		1.17		20.74		1.07		1.90		23455	6765	
MCR-23	23	21.94		1.17		21.74		1.07		1.90		24521	7511	
MCR-24	24	22.94		1.17		22.74		1.07	+0.05	1.90		25587	8297	
MCR-25	25	23.88		1.17		23.68		1.07	-0.05	1.90		26653	9608	
MCR-26	26	24.84		1.17		24.69		1.07		1.90		27719	10412	
MCR-27	27	25.80		1.42		25.55		1.27		2.24		31195	8706	
MCR-28	28	26.80		1.42		26.55		1.27		2.24		32350	9487	
MCR-29	29	27.74		1.42		27.46		1.27		2.24		33506	10629	
MCR-30	30	28.68		1.42		28.40		1.27		2.24		34661	12032	
MCR-32	32	30.60		1.42		30.32		1.27		2.50		36972	14621	
MCR-33	33	31.50	+0.10	1.42		31.22	+0.00	1.27		2.50	+0.08	38127	16774	
MCR-34	34	32.40	-0.10	1.42		32.12	-0.40	1.27		2.50	-0.13	39283	18781	
MCR-35	35	33.36		1.42		33.06		1.27		2.75		40438	19917	
MCR-36	36	34.28		1.42		33.98		1.27		2.75		41953	21377	
MCR-37	37	35.28		1.42	+0.10	34.88		1.27		2.75		42749	21971	
MCR-38	38	36.20		1.42	-0.00	35.90		1.27		2.75		43904	23614	
MCR-39	39	37.70		1.73		37.40		1.58		3.00		56058	22989	
MCR-40	40	38.12		1.73		37.76		1.58		3.00		57496	24462	
MCR-42	42	40.08		1.73		39.72		1.58		3.00		60370	27840	
MCR-43	43	41.08		1.73		40.69	+0.00	1.58		3.00		61808	28503	
MCR-44	44	41.96	+0.13	1.73		41.60	-0.50	1.58		3.25		63245	29166	
MCR-45	45	42.90	-0.13	1.73		42.54		1.58		3.25		64683	32625	
MCR-47	47	44.80		1.73		44.39		1.58		3.25		67557	35698	
MCR-48	48	45.80		1.73		45.39		1.58	+0.08	3.25		68995	36457	
MCR-50	50	47.70		1.73		47.29		1.58	-0.08	3.25		71870	39703	
MCR-52	52	49.66		2.18		49.28		1.98		3.58		93667	42009	
MCR-53	53	50.60		2.18		50.25		1.98		3.58		95468	43914	
MCR-54	54	51.50		2.18		51.11		1.98		3.58		97270	46607	
MCR-55	55	52.46		2.18		52.05		1.98		3.58		99071	48230	
MCR-56	56	53.46	+0.15	2.18	+0.13	53.06	+0.00	1.98		3.58		100872	49107	
MCR-58	58	55.26	-0.15	2.18	-0.00	54.83	-0.63	1.98		3.58		104475	54865	
MCR-59	59	56.26		2.18		55.75		1.98		3.58		106276	55811	
MCR-60	60	57.20		2.18		56.77		1.98		3.58		108077	58000	
MCR-61	61	58.20		2.18		57.73		1.98		3.58		109879	58967	
MCR-62	62	59.16		2.18		58.70		1.98		3.58		111680	60790	

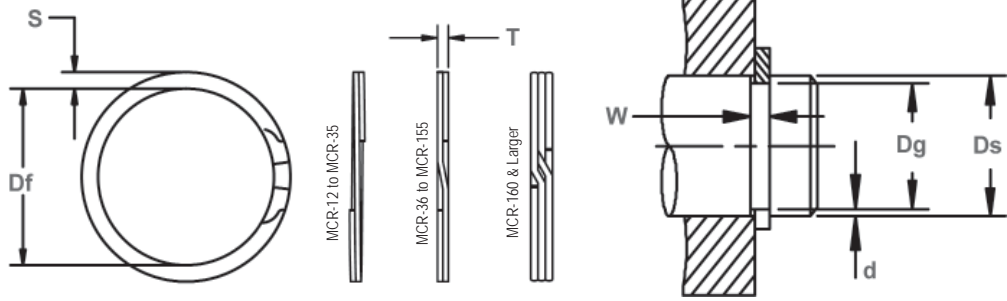

Free Diameter & Ring Measurements

Shaft Diameter & Groove Dimensions

RING NO.	SHAFT DIAMETER (mm)	GROOVE SIZE				FREE DIAMETER		RING SIZE THICKNESS		SECTION		THRUST LOAD (N)	
		DIAMETER		WIDTH		Df	Tol.	T	Tol.	S	Tol.	Ring Safety factor of 3	Groove Safety factor of 2
		Dg	Tol.	W	Tol.								
MCR-63	63	60.10		2.18		59.62		1.98		4.77		113481	63075
MCR-64	64	61.10		2.18		60.62		1.98		4.77		115282	64076
MCR-65	65	62.10		2.18		61.62	+0.00	1.98		4.77		117084	65078
MCR-66	66	63.04		2.18		62.58	-0.63	1.98		4.77		118885	67446
MCR-67	67	63.90		2.18		64.38		1.98		4.77		120686	71706
MCR-68	68	64.90		2.18		64.40		1.98		4.77		122488	72777
MCR-69	69	65.90		2.18		65.38		1.98		4.77		124289	73847
MCR-70	70	66.86		2.62		66.33		2.36		4.77		143133	75884
MCR-71	71	67.70		2.62		67.15		2.36		4.77		145177	80890
MCR-72	72	68.70		2.62		68.20		2.36		4.77		147222	82029
MCR-75	75	71.54	+0.15	2.62	+0.13	71.00	+0.00	2.36	+0.08	4.77	+0.10	153356	89590
MCR-78	78	74.40	-0.15	2.62	-0.00	73.82	-0.75	2.36	-0.08	4.77	-0.15	159491	96943
MCR-80	80	76.30		2.62		75.69		2.36		4.77		163580	102191
MCR-82	82	78.20		2.62		77.57		2.36		4.77		167670	107577
MCR-85	85	81.10		2.62		80.44		2.36		4.77		173804	114447
MCR-88	88	84.00		2.62		83.34		2.36		4.77		179938	121524
MCR-90	90	85.90		3.05		85.27		2.82		6.35		219897	127393
MCR-95	95	90.60		3.05		89.91		2.82		6.35		232114	144310
MCR-100	100	95.40		3.05		94.70		2.82		6.35		244330	158810
MCR-105	105	100.32		3.05		99.61	+0.00	2.82		6.35		256547	169651
MCR-110	110	105.32		3.05		104.60	-1.00	2.82		6.35		268763	177729
MCR-115	115	110.16		3.05		109.40		2.82		6.35		280980	192160
MCR-120	120	114.92		3.05		114.03		2.82		6.35		293197	210458
MCR-125	125	119.70		3.05		118.81		2.82		6.35		305413	228721
MCR-130	130	124.56		3.05		123.65		2.82		6.35		317630	244153
MCR-135	135	129.40		3.53		128.50		3.23		9.52		377802	261001
MCR-140	140	134.06	+0.18	3.53	+0.15	133.15	+0.00	3.23	+0.10	9.52		391795	287101
MCR-145	145	138.80	-0.18	3.53	-0.00	137.80	-1.27	3.23	-0.10	9.52		405788	310370
MCR-150	150	143.64		3.53		142.60		3.23		9.52		419780	329359
MCR-155	155	148.50		3.53		147.43		3.23		9.52		433773	347829
MCR-160	160	153.30		4.42		152.11		4.20		7.92		582234	370097
MCR-165	165	158.00		4.42		156.81		4.20		7.92		600429	398752
MCR-170	170	162.80		4.42		161.61	+0.00	4.20		7.92		618624	422573
MCR-175	175	167.60		4.42		166.41	-1.52	4.20		7.92		636819	447085
MCR-180	180	172.40		4.42		171.20		4.20		7.92	+0.10	655014	472288
MCR-185	185	177.40		4.42		176.18		4.20		7.92	-0.20	673208	485407
MCR-190	190	182.40	+0.20	5.30	+0.20	181.13		4.80	+0.13	9.52		790175	498526
MCR-195	195	186.60	-0.20	5.30	-0.00	185.33		4.80	-0.13	9.52		810969	565503
MCR-200	200	191.52		5.30		190.14		4.80		9.52		831763	585526
MCR-210	210	201.20		5.30		199.80		4.80		9.52		873351	638003
MCR-220	220	210.80		5.30		209.30	+0.00	4.80		9.52		914940	698765
MCR-230	230	220.36		5.30		218.74	-1.78	4.80		9.52		956528	765465
MCR-240	240	230.00		5.30		228.30		4.80		9.52		998116	828575
MCR-250	250	239.40		5.30		237.70		4.80		9.52		1039704	914885
MCR-260	260	249.20		5.30		247.50		4.80		9.52		1081292	969433
MCR-270	270	259.10		5.30		257.33		4.80		9.52		1122880	1016040
MCR-280	280	269.00		5.30		267.17		4.80		9.52		1164468	1063338



# MKG Spiral Housing Rings

## Internal, Heavy Duty, Metric

These 2-turn rings provide 360° groove contact and are ideal for applications with high thrust loads.

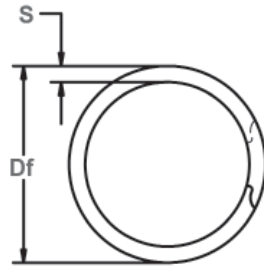

Free Diameter & Ring Measurements

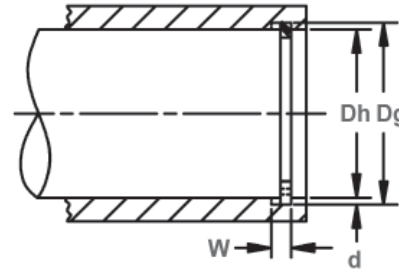

Housing Diameter & Groove Dimensions

RING NO.	HOUSING DIAMETER (mm)	GROOVE SIZE				RING SIZE				THRUST LOAD (N)			
		DIAMETER		WIDTH		FREE DIAMETER		THICKNESS		SECTION		RING Safety factor of 3	GROOVE Safety factor of 2
		Dg	Tol.	W	Tol.	Df	Tol.	T	Tol.	S	Tol.		
MKG-12	12	12.70		0.70		12.89		0.60		1.14		7954	1794
MKG-13	13	13.75		1.00		13.95		0.89		1.14		11528	1421
MKG-14	14	14.85	+0.05	1.00		15.07		0.89		1.40		12415	1925
MKG-15	15	15.90	-0.05	1.00		16.14		0.89		1.40		13302	2318
MKG-16	16	16.95		1.00		17.15		0.89		1.40		14188	2660
MKG-17	17	18.05		1.00		18.32		0.89		1.65		15075	3507
MKG-18	18	19.10		1.00		19.39		0.89		1.65		15962	4089
MKG-19	19	20.17		1.00	+0.08	20.48		0.89		1.65		16849	4817
MKG-20	20	21.22		1.00	-0.00	21.51		0.89		1.90		17736	5556
MKG-21	21	22.26		1.00		22.56		0.89	+0.05	1.90		18622	6286
MKG-22	22	23.37		1.20		23.65		1.07	-0.05	1.90		23455	6200
MKG-23	23	24.42	+0.08	1.20		24.69		1.07		2.16		24521	7040
MKG-24	24	25.47	-0.08	1.20		25.73		1.07		2.16		25587	7819
MKG-25	25	26.67		1.20		27.03		1.07		2.16		26653	9992
MKG-26	26	27.77		1.20		28.07	+0.35	1.07		2.16	+0.08	27719	11102
MKG-27	27	28.87		1.40		29.11	-0.00	1.27		2.62	-0.13	31195	9571
MKG-28	28	29.87		1.40		30.10		1.27		2.62		32350	10153
MKG-29	29	30.95		1.40		31.21		1.27		2.62		33506	11428
MKG-30	30	32.00		1.40		32.28		1.27		2.62		34661	12552
MKG-31	31	33.05		1.40		33.32		1.27		2.62		35817	13599
MKG-32	32	34.00		1.40		34.23		1.27		2.62		36972	13830
MKG-34	34	36.20		1.40		36.46		1.27		3.00		39283	17447
MKG-35	35	37.30		1.40		37.55		1.27		3.00		40438	19195
MKG-36	36	38.40	+0.10	1.40	+0.10	38.68		1.27		3.00		41593	21326
MKG-37	37	39.40	-0.10	1.40	-0.00	39.60		1.27		3.00		42749	21876
MKG-38	38	40.50		1.40		40.77		1.27		3.00		43904	24484
MKG-40	40	42.50		1.75		42.91		1.57		3.25		57132	22319
MKG-42	42	44.60		1.75		45.01		1.57		3.25		59988	25347
MKG-45	45	47.70		1.75		48.13		1.57		3.25		64273	29964
MKG-46	46	48.80		1.75		49.28		1.57		3.25		65701	32717
MKG-47	47	49.90		1.75		50.32		1.57		4.01		67130	35606
MKG-48	48	51.00		1.75		51.46		1.57	+0.08	4.01		68558	38663
MKG-50	50	53.20		1.75		53.66		1.57	-0.08	4.01		71415	44490
MKG-52	52	55.45		2.15		55.91		1.98		4.27		93667	40681
MKG-55	55	58.55		2.15		59.28		1.98		4.27		99071	48699
MKG-57	57	60.65	+0.15	2.15	+0.20	60.93	+0.65	1.98		4.27	+0.10	102673	49284
MKG-58	58	61.75	-0.15	2.15	-0.00	62.66	-0.00	1.98		5.08	-0.15	104475	91487
MKG-60	60	63.95		2.15		64.39		1.98		5.08		108077	99943
MKG-62	62	65.95		2.15		66.40		1.98		5.08		111680	109065
MKG-63	63	67.05		2.15		67.74		1.98		5.08		113481	121272





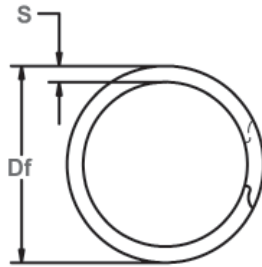

Free Diameter & Ring Measurements

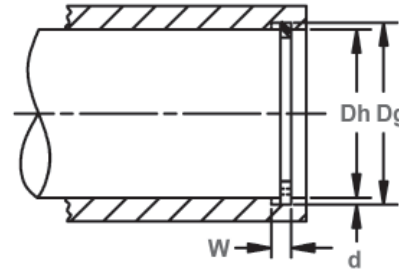

Housing Diameter & Groove Dimensions

RING NO.	HOUSING DIAMETER (mm)	GROOVE SIZE				RING SIZE						THRUST LOAD (N)	
		DIAMETER		WIDTH		FREE DIAMETER		THICKNESS		SECTION		RING Safety factor of 3	GROOVE Safety factor of 2
		Dg	Tol.	W	Tol.	Df	Tol.	T	Tol.	S	Tol.		
MKG-65	65	69.15		2.55		69.63		2.29		5.72		128967	62641
MKG-68	68	72.35		2.55		72.86	+0.75	2.29		5.72		134919	71755
MKG-70	70	74.55		2.55		75.06	-0.00	2.29		5.72		138887	79264
MKG-72	72	76.65		2.55		77.18		2.29		5.72		142855	85617
MKG-75	75	79.85		2.55		80.40		2.29		5.72		148808	96681
MKG-78	78	82.95		2.95		83.53		2.72		7.14		183820	91487
MKG-80	80	85.15		2.95		85.74		2.72		7.14		188533	99943
MKG-82	82	87.35		2.95		87.96		2.72		7.14		193246	109065
MKG-85	85	90.55	+0.15	2.95		91.18		2.72		7.14		200316	121272
MKG-88	88	93.75	-0.15	2.95		94.41		2.72		7.14		207386	134554
MKG-90	90	95.85		2.95	+0.20	96.51		2.72	+0.08	7.14		212100	142716
MKG-92	92	97.95		2.95	-0.00	98.64		2.72	-0.08	7.14		216813	151766
MKG-95	95	101.15		2.95		101.86	+0.90	2.72		7.92		223883	168598
MKG-98	98	104.35		2.95		105.09	-0.00	2.72		7.92		230953	185160
MKG-100	100	106.50		2.95		107.29		2.72		7.92		235666	197997
MKG-102	102	108.60		2.95		109.42		2.72		7.92		240380	209267
MKG-105	105	111.70		2.95		112.52		2.72		7.92		247450	224146
MKG-108	108	114.80		2.95		115.64		2.72		7.92		254520	240221
MKG-110	110	116.90		2.95		117.77		2.72		7.92		259233	253044
MKG-115	115	122.10		2.95		123.00		2.72		7.92		271016	281888
MKG-120	120	127.20	+0.20	2.95		128.14		2.72		7.92		282799	298287
MKG-125	125	132.30	-0.20	2.95		133.28		2.72		7.92		294583	315031
MKG-130	130	137.40		2.95		138.40		2.72		7.92		306366	332121
MKG-135	135	142.50		3.40		143.53		3.12		8.89	+0.10	364936	349555
MKG-140	140	146.70		3.40		148.64	+1.25	3.12	+0.10	8.89	-0.20	378452	367335
MKG-145	145	152.70		3.40		153.79	-0.00	3.12	-0.10	8.89		391968	385460
MKG-150	150	157.80		3.40		158.93		3.12		8.89		405485	403930
MKG-155	155	162.90		3.40		164.05		3.12		8.89		419001	422746
MKG-160	160	168.00		4.25		169.18		3.78		9.65		524011	429949
MKG-165	165	173.15		4.25		174.42	+1.40	3.78		9.65		540386	464261
MKG-170	170	178.25		4.25		179.55	-0.00	3.78		9.65		556761	484199
MKG-175	175	183.45		4.25	+0.25	184.78		3.78		9.65		573137	510523
MKG-180	180	188.65		4.25	-0.00	190.01		3.78		9.65		589512	537538
MKG-185	185	193.85		5.10		195.25		4.55		10.62		729309	530579
MKG-190	190	199.05	+0.25	5.10		200.50		4.55	+0.13	10.62		749020	572409
MKG-200	200	209.25	-0.25	5.10		210.76		4.55	-0.13	10.62		788442	638693
MKG-210	210	219.65		5.10		221.22	+1.80	4.55		10.62		827864	699628
MKG-220	220	230.25		5.10		231.91	-0.00	4.55		10.62		867286	778515
MKG-230	230	240.85		5.10		242.59		4.55		10.62		906709	861546
MKG-240	240	251.25		5.10		253.06		4.55		10.62		946131	932147
MKG-250	250	261.65		5.10		263.12		4.55		10.62		985553	1005511

# MCG Spiral Shaft Rings

## External, Heavy Duty, Metric

These 2-turn rings provide 360° groove contact and are ideal for applications with high thrust loads.

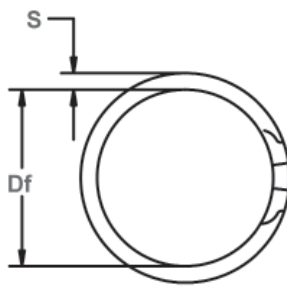

Free Diameter & Ring Measurements

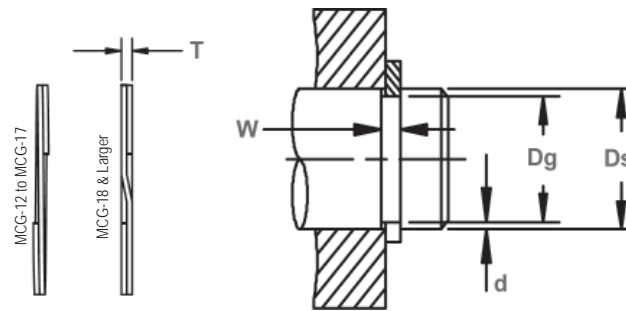

Shaft Diameter & Groove Dimensions

RING NO.	SHAFT DIAMETER (mm)	GROOVE SIZE				RING SIZE						THRUST LOAD (N)	
		DIAMETER		WIDTH		FREE DIAMETER		THICKNESS		SECTION		RING Safety factor of 3	GROOVE Safety factor of 2
		Dg	Tol.	W	Tol.	Df	Tol.	T	Tol.	S	Tol.		
MCG-12	12	11.29		0.70		11.18		0.60		1.14		7954	2461
MCG-13	13	12.24	+0.06	1.00		12.13		0.89		1.27		11528	1930
MCG-14	14	13.19	-0.06	1.00		13.06		0.89		1.27		12415	2384
MCG-15	15	14.09		1.00		13.98		0.89		1.27		13302	3181
MCG-16	16	15.03		1.00		14.90		0.89		1.40		14188	3811
MCG-17	17	16.03		1.00		15.82		0.89		1.40		15075	4107
MCG-18	18	16.93		1.20		16.80		1.07		1.65		19190	4561
MCG-19	19	17.88		1.20		17.73		1.07		1.65		20256	5309
MCG-20	20	18.78	+0.07	1.20	+0.08	18.62		1.07		1.65		21323	6427
MCG-21	21	19.73	-0.07	1.20	-0.00	19.57		1.07		1.65		22389	7470
MCG-22	22	20.63		1.20		20.45	+0.00	1.07	+0.05	1.91	+0.08	23455	8686
MCG-23	23	21.58		1.20		21.39	-0.33	1.07	-0.05	1.91	-0.13	24521	9906
MCG-24	24	22.53		1.20		22.35		1.07		1.91		25587	11366
MCG-25	25	23.43		1.20		23.25		1.07		2.16		26653	13132
MCG-26	26	24.43		1.20		24.21		1.07		2.16		27719	14085
MCG-27	27	25.35		1.40		25.04		1.27		2.62		31195	10968
MCG-28	28	26.30		1.40		26.00		1.27		2.62		32350	12439
MCG-29	29	27.27		1.40		26.95		1.27		2.62		33506	13626
MCG-30	30	28.25	+0.10	1.40	+0.10	27.92		1.27		2.62		34661	14898
MCG-31	31	29.17	-0.10	1.40	-0.00	28.84		1.27		2.62		35817	16835
MCG-32	32	30.10		1.40		29.77		1.27		2.62		36972	18840
MCG-34	34	31.90		1.40		31.54		1.27		3.00		39283	23123
MCG-35	35	32.80		1.40		32.44		1.27		3.00		40438	25932
MCG-36	36	33.75		1.40		33.40		1.27		3.00		41593	27964
MCG-37	37	34.67	+0.15	1.40		34.24		1.27		3.00		42749	29763
MCG-38	38	35.65	-0.15	1.40		35.18		1.27		3.00		43904	30830

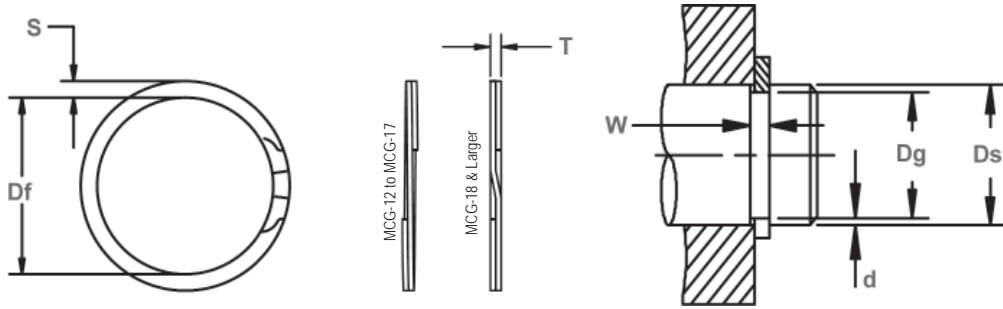

Free Diameter & Ring Measurements

Shaft Diameter & Groove Dimensions

RING NO.	SHAFT DIAMETER (mm)	GROOVE SIZE				RING SIZE						THRUST LOAD (N)	
		DIAMETER		WIDTH		FREE DIAMETER		THICKNESS		SECTION		RING Safety factor of 3	GROOVE Safety factor of 2
		Dg	Tol.	W	Tol.	Df	Tol.	T	Tol.	S	Tol.		
MCG-40	40	37.55	+0.15 -0.15	1.75	+0.10 -0.00	37.15	+0.00 -0.51	1.57	+0.08 -0.08	3.25	+0.08 -0.13	57132	30470
MCG-42	42	39.45		1.75		39.02		1.57		3.25		59988	35208
MCG-45	45	42.25		1.75		41.77		1.57		3.25		64273	42723
MCG-46	46	43.15		1.75		42.67		1.57		3.25		65701	45261
MCG-47	47	44.31		1.75		43.81		1.57		4.01		67130	43649
MCG-48	48	45.05		1.75		44.48		1.57		4.01		68558	48886
MCG-50	50	47.05		1.75		46.69		1.57		4.01		71415	50923
MCG-52	52	48.95		2.15		48.60		1.98		4.27		93667	53451
MCG-54	54	50.85		2.15		50.52		1.98		4.27		97270	58725
MCG-55	55	51.65		2.15		51.26		1.98		4.27		99071	63610
MCG-57	57	53.60	+0.20 -0.20	2.15	+0.13 -0.00	53.17	+0.00 -0.64	1.98	+0.10 -0.15	4.27	+0.10 -0.15	102673	66907
MCG-58	58	54.50		2.15		54.08		1.98		4.27		104475	70084
MCG-60	60	56.50		2.15		56.05		1.98		5.08		108077	72500
MCG-62	62	58.40		2.15		57.99		1.98		5.08		111680	77057
MCG-65	65	61.40		2.15		60.92		1.98		5.08		117084	80786
MCG-68	68	64.30		2.15		63.80		1.98		5.08		122488	86862
MCG-70	70	66.20		2.55		65.70		2.29		5.72		138887	91834
MCG-72	72	68.10		2.55		67.57		2.29		5.72		142855	96943
MCG-75	75	71.00		2.55		70.47		2.29		5.72		148808	103572
MCG-78	78	73.80		2.55		73.25		2.29		5.72		154760	113101
MCG-80	80	75.70	2.55	75.12	2.29	5.72	158728	118762					
MCG-82	82	77.60	2.55	77.00	2.29	5.72	162696	124562					
MCG-85	85	80.40	2.55	79.79	2.29	5.72	168649	134989					
MCG-88	88	83.30	2.95	82.67	2.72	6.86	207386	142791					
MCG-90	90	85.20	2.95	84.54	2.72	6.86	212110	149144					
MCG-95	95	90.00	2.95	89.32	2.72	6.86	223883	163989					
MCG-100	100	94.80	2.95	94.09	2.72	6.86	235666	179525					



# MKA Spiral Housing Rings

**Internal, Aerospace, Metric**

Dimensions Conform to Metric Aerospace

Specification MA 4017\*.

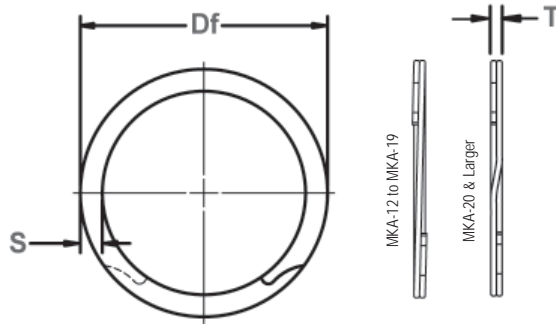

Free Diameter & Ring Measurements

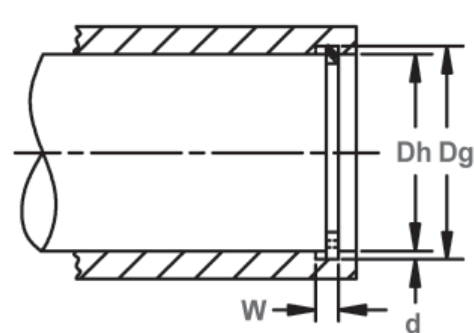

Housing Diameter & Groove Dimensions

RING NO.	HOUSING DIAMETER (mm)	GROOVE SIZE				RING SIZE				THRUST LOAD (N)		
		DIAMETER		WIDTH		FREE DIAMETER		THICKNESS		SECTION S	RING Safety factor of 3	GROOVE Safety factor of 2
		Dh	Dg	Tol.	W	Tol.	Df	Tol.	T			
MKA-12	12.00	12.70	±0.05	0.70	+0.15/-0.00	12.89	±0.35	0.60	±0.05	1.02-1.22	7950	2050
MKA-13	13.00	13.75		1.00	13.95	0.89		1.02-1.22		12110	2410	
MKA-14	14.00	14.85		1.00	15.07	0.89		1.27-1.47		13040	2930	
MKA-15	15.00	15.90		1.00	16.14	0.89		1.27-1.47		13970	3290	
MKA-16	16.00	16.95		1.00	17.15	0.89		1.27-1.47		14900	3740	
MKA-17	17.00	18.05		1.00	18.32	0.89		1.52-1.73		15830	4390	
MKA-18	18.00	19.10		1.00	19.39	0.89		1.52-1.73		16760	4820	
MKA-19	19.00	20.17		1.00	20.48	0.89		1.52-1.73		17690	5460	
MKA-20	20.00	21.22		1.00	21.51	0.89		1.78-1.98		18620	5940	
MKA-21	21.00	22.27		1.00	22.56	0.89		1.78-1.98		19550	6550	
MKA-22	22.00	23.37	±0.075	1.20	23.65	±0.35	1.07	±0.05	1.78-1.98	24630	7390	
MKA-23	23.00	24.42		1.20	24.69		1.07		2.03-2.24	25750	7950	
MKA-24	24.00	25.47		1.20	25.73		1.07		2.03-2.24	26870	8650	
MKA-25	25.00	26.67		1.20	27.03		1.07		2.03-2.24	27990	10230	
MKA-26	26.00	27.77		1.20	28.07		1.07		2.03-2.24	29110	11270	
MKA-27	27.00	28.87		1.40	29.11		1.27		2.49-2.69	31170	12360	
MKA-28	28.00	29.87		1.40	30.10		1.27		2.49-2.69	32330	12820	
MKA-29	29.00	30.95		1.40	31.21		1.27		2.49-2.69	33480	13840	
MKA-30	30.00	32.00		1.40	32.28		1.27		2.49-2.69	34640	14610	
MKA-31	31.00	33.05		1.40	33.32		1.27		2.49-2.69	35790	15550	
MKA-32	32.00	34.00	1.40	34.23	1.27	2.49-2.69	36950	15880				
MKA-34	34.00	36.20	1.40	36.46	1.27	2.87-3.07	39260	18210				
MKA-35	35.00	37.30	±0.10	1.40	37.55	±0.51	1.27	±0.075	2.87-3.07	40410	19600	
MKA-36	36.00	38.40		1.40	38.68		1.27		2.87-3.07	41560	21040	
MKA-37	37.00	39.40		1.40	39.60		1.27		2.87-3.07	42720	21620	
MKA-38	38.00	40.50		1.40	40.77		1.27		2.87-3.07	43870	23130	
MKA-40	40.00	42.50		1.75	42.91		1.57		3.12-3.33	57090	24350	
MKA-42	42.00	44.60		1.75	45.01		1.57		3.12-3.33	59950	26590	
MKA-45	45.00	47.70		1.75	48.13		1.57		3.12-3.33	64230	29590	
MKA-46	46.00	48.80		1.75	49.28		1.57		3.12-3.33	65660	31370	
MKA-47	47.00	49.90		1.75	50.32		1.57		3.89-4.09	67080	33190	
MKA-48	48.00	51.00		1.75	51.46		1.57		3.89-4.09	68510	35070	
MKA-50	50.00	53.20	1.75	53.66	1.57	3.89-4.09	71370	38960				
MKA-52	52.00	53.79	±0.125	1.42	54.30	±0.50	1.25	±0.075	3.12-3.33	59090	22790	
MKA-53	53.00	54.79		1.42	55.32		1.25		3.12-3.33	60230	23230	
MKA-55	55.00	56.85	±0.15	1.42	57.38	±0.63	1.25	±0.08	3.38-3.58	62500	24910	
MKA-56	56.00	57.85		1.42	58.40		1.25		3.38-3.58	63640	25360	
MKA-58	58.00	59.85		1.42	60.43		1.25		3.38-3.58	65910	26270	
MKA-59	59.00	60.93		1.42	61.54		1.25		3.38-3.58	67050	27870	
MKA-60	60.00	61.99		1.42	62.57		1.25		3.38-3.58	68180	29220	
MKA-61	61.00	63.09		1.42	63.65		1.25		3.63-3.84	69320	31190	
MKA-62	62.00	64.09		1.42	64.70		1.25		3.63-3.84	70460	31700	
MKA-63	63.00	65.09		1.42	65.70		1.25		3.63-3.84	71590	32220	
MKA-64	64.00	66.19		1.42	66.77		1.25		3.63-3.84	72730	34290	
MKA-65	65.00	67.19		1.42	67.82		1.25		3.63-3.84	73870	34820	
MKA-66	66.00	68.19	1.42	68.80	1.25	3.63-3.84	75000	35360				
MKA-67	67.00	69.25	1.42	69.90	1.25	3.63-3.84	76140	36870				

ALL DIMENSIONS IN MILLIMETERS UNLESS OTHERWISE STATED.

\*Contact factory on particulars for rings to meet aerospace specifications.



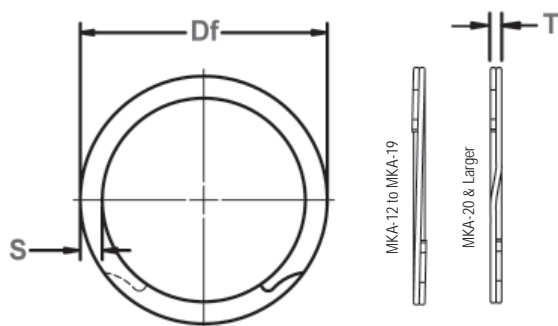

Free Diameter & Ring Measurements

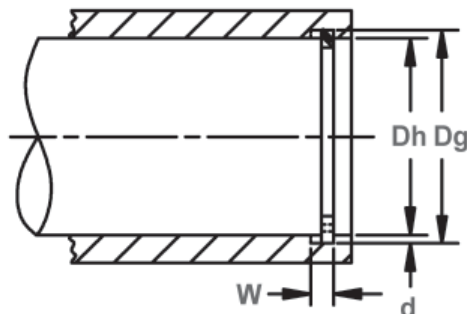

Housing Diameter & Groove Dimensions

RING NO.	HOUSING DIAMETER (mm)		GROOVE SIZE				RING SIZE				THRUST LOAD (N)	
			DIAMETER		WIDTH		FREE DIAMETER		THICKNESS		SECTION	RING Safety factor of 3
	Dh	Dg	Tol.	W	Tol.	Df	Tol.	T	Tol.	S		
MKA-68	68.00	70.29		1.42		70.94		1.25		3.88-4.09	77270	38090
MKA-69	69.00	71.29		1.42		71.94		1.25		3.88-4.09	78410	38650
MKA-70	70.00	72.29		1.42	+0.10	72.94	+0.63	1.25		3.88-4.09	79550	39210
MKA-71	71.00	73.29		1.42	-0.00	73.99	-0.00	1.25		3.88-4.09	80680	39770
MKA-72	72.00	74.39		1.42		75.04		1.25		4.11-4.39	81510	40910
MKA-75	75.00	77.39		1.42		78.07		1.25		4.11-4.39	85230	43830
MKA-78	78.00	80.45		1.73		81.21		1.55		4.11-4.39	109910	46730
MKA-80	80.00	82.49		1.73		83.22		1.55		4.37-4.62	112730	48700
MKA-82	82.00	84.55		1.73		85.28		1.55		4.37-4.62	115550	51120
MKA-85	85.00	87.65		1.73		88.38		1.55	±0.08	4.62-4.88	119780	55060
MKA-88	88.00	90.69		1.73		91.45	+0.76	1.55		4.62-4.88	124000	57860
MKA-90	90.00	92.79	±0.15	1.73		93.58	-0.00	1.55		4.88-5.13	126820	61370
MKA-92	92.00	94.85		1.73		95.66		1.55		4.88-5.13	129640	64070
MKA-95	95.00	97.85		1.73		98.69		1.55		4.88-5.13	133870	66160
MKA-98	98.00	100.99		1.73	+0.13	101.83		1.55		5.13-5.38	138090	71590
MKA-100	100.00	102.99		1.73	-0.00	103.83		1.55		5.13-5.38	140910	73050
MKA-102	102.00	105.15		1.73		106.00		1.55		5.38-5.64	143730	78490
MKA-105	105.00	108.15		1.73		109.00		1.55		5.38-5.64	147960	80800
MKA-108	108.00	111.31		1.73		112.22		1.55		5.64-5.89	152190	87310
MKA-110	110.00	113.31		1.73		114.25		1.55		5.64-5.89	155000	62140
MKA-112	112.00	115.45		1.73		116.44	+0.90	1.55		5.89-6.15	157820	94370
MKA-115	115.00	118.45		1.73		119.44	-0.00	1.55		5.89-6.15	162050	96890
MKA-120	120.00	123.55		2.00		124.54		1.83		6.20-6.45	199640	104030
MKA-125	125.00	128.55		2.00		129.59		1.83		6.20-6.45	207960	108360
MKA-130	130.00	133.65		2.00		134.71		1.83		6.20-6.45	216280	115860
MKA-135	135.00	138.62		2.00		139.74		1.83		6.20-6.45	224600	119000
MKA-140	140.00	143.72	±0.18	2.00		144.87	+1.14	1.83		6.20-6.45	232920	126820
MKA-145	145.00	148.82		2.00		150.04	-0.00	1.83		6.20-6.45	241230	134880
MKA-150	150.00	153.82		2.00		155.07		1.83		6.20-6.45	249550	139530
MKA-155	155.00	159.40		2.40		160.72		2.18		7.72-8.03	307190	166080
MKA-160	160.00	164.40		2.40		165.74		2.18		7.72-8.03	317100	171433
MKA-165	165.00	169.40		2.40		170.77	+1.40	2.18		7.72-8.03	327010	176790
MKA-170	170.00	174.60		2.40		176.05	-0.00	2.18		7.72-8.03	336920	190430
MKA-175	175.00	179.60		2.40		181.05		2.18	±0.10	7.72-8.03	346830	196030
MKA-180	180.00	184.88		2.40		186.38		2.18		7.72-8.03	356740	213900
MKA-185	185.00	189.88		2.40		191.10		2.18		7.72-8.03	366650	219840
MKA-190	190.00	194.88	±0.20	2.40	+0.15	196.45		2.18		7.72-8.03	376560	225790
MKA-195	195.00	200.14		2.40	-0.00	201.74		2.18		7.72-8.03	386460	244070
MKA-200	200.00	205.14		2.40		206.76		2.18		7.72-8.03	396370	250330
MKA-210	210.00	215.40		2.40		217.10	+1.65	2.18		9.32-9.63	416490	276140
MKA-220	220.00	225.64		2.40		227.40	-0.00	2.18		9.32-9.63	436010	257150
MKA-230	230.00	235.90		2.40		237.73		2.18		9.32-9.63	455830	330450
MKA-240	240.00	245.90		2.40		247.80		2.18		9.32-9.63	475650	344810
MKA-250	250.00	256.16		2.40		258.10		2.18		9.32-9.63	495470	375010
MKA-260	260.00	266.40		2.40		268.43		2.18		9.32-9.63	515290	405210
MKA-270	270.00	276.40		2.40		278.50		2.18		9.32-9.63	535100	420790
MKA-280	280.00	286.66		2.40		288.82		2.18		9.32-9.63	554920	454100

ALL DIMENSIONS IN MILLIMETERS UNLESS OTHERWISE STATED.



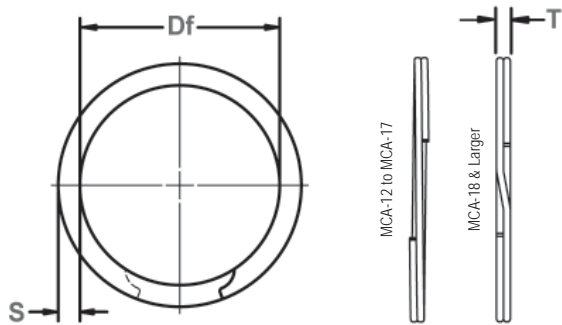

Free Diameter & Ring Measurements

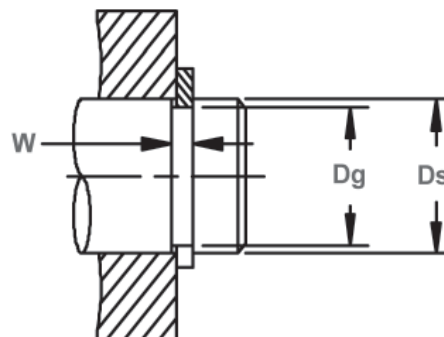

Shaft Diameter & Groove Dimensions

RING NO.	SHAFT DIAMETER (mm)	GROOVE SIZE				RING SIZE				THRUST LOAD (N)		R.P.M. LIMITS Standard Material (Carbon Steel)	
		DIAMETER		WIDTH		FREE DIAMETER		THICKNESS		SECTION S	RING Safety factor of 3		GROOVE Safety factor of 2
		Ds	Dg	Tol.	W	Tol.	Df	Tol.	T				
MCA-12	12	11.29	±0.06	0.70	+0.08 -0.00	11.18	+0.00 -0.33	0.60	±0.05	1.02-1.22	7950	2100	22153
MCA-13	13	12.24		1.00		12.13		0.89		1.14-1.35	12100	2410	20094
MCA-14	14	13.19		1.00		13.06		0.89		1.14-1.35	13040	2800	18471
MCA-15	15	14.09	1.00	13.98		0.89		1.14-1.35		13970	3360	14543	
MCA-16	16	15.02	1.00	14.90		0.89		1.27-1.48		14900	3820	14149	
MCA-17	17	16.02	1.00	15.82		0.89		1.27-1.48		15830	4060	15923	
MCA-18	18	16.92	1.20	16.80		1.07		1.52-1.73		20150	4730	12233	
MCA-19	19	17.87	1.20	17.73		1.07		1.52-1.73		21270	5270	11685	
MCA-20	20	18.77	±0.075	1.20		18.62		1.07		1.52-1.73	22390	6040	10810
MCA-21	21	19.72	±0.075	1.20		19.57		1.07		1.52-1.73	23510	6550	9641
MCA-22	22	20.62	±0.075	1.20	20.45	1.07	1.78-1.98	24630	7390	10397			
MCA-23	23	21.57	±0.075	1.20	21.39	1.07	1.78-1.98	25750	8070	9652			
MCA-24	24	22.52	±0.10	1.20	22.35	1.07	1.78-1.98	26870	8650	8479			
MCA-25	25	23.42	±0.10	1.20	23.25	1.07	2.03-2.24	27990	9620	8524			
MCA-26	26	24.42	±0.10	1.20	24.21	1.07	2.03-2.24	29110	10000	8642			
MCA-27	27	25.35	±0.10	1.40	25.04	1.27	2.49-2.69	31170	10910	11357			
MCA-28	28	26.30	±0.10	1.40	26.00	1.27	2.49-2.69	32330	11590	10259			
MCA-29	29	27.27	±0.10	1.40	26.95	1.27	2.49-2.69	33480	12290	9765			
MCA-30	30	28.25	±0.10	1.40	27.92	1.27	2.49-2.69	34640	12860	9149			
MCA-31	31	29.17	±0.10	1.40	28.84	1.27	2.49-2.69	35790	13890	8495			
MCA-32	32	30.10	±0.10	1.40	29.77	1.27	2.49-2.69	36950	14960	7778			
MCA-34	34	31.90	±0.15	1.40	31.54	1.27	2.87-3.07	39260	17390	7982			
MCA-35	35	32.80	±0.15	1.40	32.44	1.27	2.87-3.07	40410	18750	7485			
MCA-36	36	33.75	±0.15	1.40	33.40	1.27	2.87-3.07	41560	19810	6903			
MCA-37	37	34.67	±0.15	1.40	34.24	1.27	2.87-3.07	42720	21080	7227			
MCA-38	38	35.65	±0.15	1.40	35.18	1.27	2.87-3.07	43870	21650	7174			
MCA-40	40	37.55	±0.15	1.75	37.15	1.57	3.12-3.33	57090	23960	6172			
MCA-42	42	39.45	±0.15	1.75	39.02	1.57	3.12-3.33	59990	26180	5715			
MCA-45	45	42.25	±0.15	1.75	41.77	1.57	3.12-3.33	64230	30240	5158			
MCA-46	46	43.15	±0.15	1.75	42.67	+0.00	3.12-3.33	65660	32040	4909			
MCA-47	47	44.31	±0.15	1.75	43.81	-0.51	3.89-4.09	67080	30900	5570			
MCA-48	48	45.05	±0.15	1.75	44.48	1.57	3.89-4.09	68510	34600	5744			
MCA-50	50	47.05	±0.15	1.75	46.69	1.57	3.89-4.09	71370	36040	4084			
MCA-52	52	50.15	±0.15	1.42	49.62	+0.00/-0.50	3.12-3.33	59090	23550	3616			
MCA-53	53	51.15	±0.15	1.42	50.62	1.25	3.12-3.33	60230	24000	3450			
MCA-54	54	52.15	±0.15	1.42	51.62	1.25	3.12-3.33	61370	24460	3295			
MCA-55	55	53.15	±0.15	1.42	52.62	1.25	3.38-3.58	62500	24910	3360			
MCA-56	56	54.15	±0.15	1.42	53.62	1.25	3.38-3.58	63640	25370	3215			
MCA-58	58	56.01	±0.15	1.42	55.43	+0.00	3.38-3.58	65910	28250	3111			
MCA-59	59	57.01	±0.15	1.42	56.43	-0.63	3.38-3.58	67050	28730	2982			
MCA-60	60	58.01	±0.15	1.42	57.43	1.25	3.38-3.58	68180	29220	2862			
MCA-61	61	58.91	±0.15	1.42	58.36	1.25	3.38-3.58	69320	31190	2683			
MCA-62	62	59.91	±0.15	1.42	59.30	1.25	3.63-3.84	70460	31710	2884			
MCA-63	63	60.91	±0.15	1.42	60.30	1.25	3.63-3.84	71590	32220	2773			
MCA-64	64	61.91	±0.15	1.42	61.25	1.25	3.63-3.84	72730	32730	2780			

ALL DIMENSIONS IN MILLIMETERS UNLESS OTHERWISE STATED.  
\*Contact factory on particulars for rings to meet aerospace specifications.

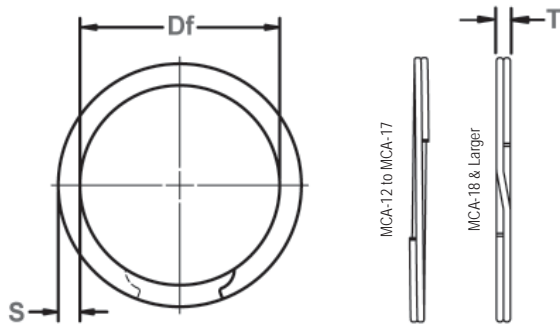

Free Diameter & Ring Measurements

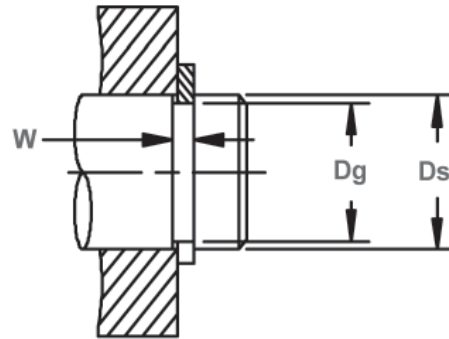

Shaft Diameter & Groove Dimensions

RING NO.	SHAFT DIAMETER (mm)	GROOVE SIZE				RING SIZE				SECTION	THRUST LOAD (N)		R.P.M. LIMITS Standard Material (Carbon Steel)
		DIAMETER		WIDTH		FREE DIAMETER		THICKNESS			RING Safety factor of 3	GROOVE Safety factor of 2	
		Ds	Dg	Tol.	W	Tol.	Df	Tol.	T				
MCA-65	65	62.81		1.42		62.20		1.25		3.63-3.84	73870	34820	2577
MCA-66	66	63.79		1.42		63.16	+0.00	1.25		3.63-3.84	75000	35680	2526
MCA-67	67	64.71		1.42		64.16	-0.63	1.25		3.63-3.84	76140	37530	2275
MCA-68	68	65.71		1.42	+0.10	65.08		1.25		3.89-4.09	77270	38090	2486
MCA-69	69	66.71		1.42	-0.00	66.06		1.25		3.89-4.09	78410	38650	2438
MCA-70	70	67.71		1.42		67.08		1.25		3.89-4.09	79550	39210	2315
MCA-71	71	68.71		1.42		68.04		1.25		3.89-4.09	80680	39770	2309
MCA-72	72	69.65		1.42		69.00	+0.00	1.25		4.11-4.37	81820	41380	2321
MCA-75	75	72.61		1.42		71.93	-0.76	1.25		4.11-4.37	85230	43830	2152
MCA-78	78	75.55		1.73		74.84		1.55	±0.08	4.11-4.37	109910	46730	2007
MCA-80	80	77.51		1.73		76.80		1.55		4.37-4.62	112730	48700	1981
MCA-82	82	79.45	±0.15	1.73		78.72		1.55		4.37-4.62	115550	51120	1895
MCA-85	85	82.35		1.73		81.62		1.55		4.62-4.88	119780	55060	1825
MCA-88	88	85.31		1.73		84.53		1.55		4.62-4.88	124000	57860	1737
MCA-90	90	87.21		1.73		86.43		1.55		4.88-5.13	126820	61370	1721
MCA-95	95	92.15		1.73		91.37		1.55		4.88-5.13	133870	66160	1509
MCA-100	100	97.01		1.73		96.10		1.55		5.13-5.38	140910	73050	1508
MCA-105	105	101.85		1.73	+0.13	100.94	+0.00	1.55		5.38-5.64	147960	80780	1399
MCA-110	110	106.69		1.73	-0.00	105.75	-1.00	1.55		5.64-5.89	155000	88930	1323
MCA-115	115	111.55		1.73		110.59		1.55		5.89-6.15	162050	96890	1248
MCA-120	120	116.45		2.00		115.49		1.83		6.20-6.45	199640	104030	1176
MCA-125	125	121.45		2.00		120.44		1.83		6.20-6.45	207960	108360	1092
MCA-130	130	126.35		2.00		125.34		1.83		6.20-6.45	216280	115860	993
MCA-135	135	131.27		2.00		130.20		1.83		6.20-6.45	224600	122950	934
MCA-140	140	136.25	±0.175	2.00		135.14	+0.00	1.83		6.20-6.45	232920	128190	870
MCA-145	145	141.17		2.00		140.00	-1.30	1.83		6.20-6.45	241230	135590	821
MCA-150	150	146.17		2.00		145.00		1.83		6.20-6.45	249550	140260	755
MCA-155	155	150.60		2.40		149.33		2.18		7.72-8.03	307190	166080	891
MCA-160	160	155.60		2.40		154.31		2.18		7.72-8.03	317100	171430	831
MCA-165	165	160.60		2.40		159.23	+0.00	2.18		7.72-8.03	327010	176790	795
MCA-170	170	165.40		2.40		164.00	-1.52	2.18		7.72-8.03	336920	190430	749
MCA-175	175	170.40		2.40		169.00		2.18		7.72-8.03	346830	196030	697
MCA-180	180	175.20		2.40		173.78		2.18	±0.10	7.72-8.03	356740	210400	657
MCA-185	185	180.20		2.40		178.70		2.18		7.72-8.03	366650	216240	631
MCA-190	190	185.20	±0.20	2.40		183.70		2.18		7.72-8.03	376560	220080	591
MCA-195	195	190.00		2.40	+0.15	188.43		2.18		7.72-8.03	386470	237420	569
MCA-200	200	195.00		2.40	-0.00	193.43		2.18		7.72-8.03	396370	243510	534
MCA-210	210	204.60		2.40		202.93		2.18		9.32-9.63	416190	276140	579
MCA-220	220	214.40		2.40		212.65	+0.00	2.18		9.32-9.63	436010	300010	530
MCA-230	230	224.40		2.40		222.60	-1.78	2.18		9.32-9.63	455830	313640	482
MCA-240	240	234.20		2.40		232.32		2.18		9.32-9.63	475650	328970	444
MCA-250	250	243.80		2.40		241.83		2.18		9.32-9.63	495470	377440	413
MCA-260	260	253.60		2.40		251.57		2.18		9.32-9.63	515290	405210	381
MCA-270	270	263.40		2.40		261.30		2.18		9.32-9.63	535100	433940	354
MCA-280	280	273.20		2.40		271.04		2.18		9.32-9.63	554920	463650	328

ALL DIMENSIONS IN MILLIMETERS UNLESS OTHERWISE STATED.

# NKG TruWave® Housing Ring

## Internal, Spiral, Inch

The waves in this spiral ring compensate for accumulated tolerances.

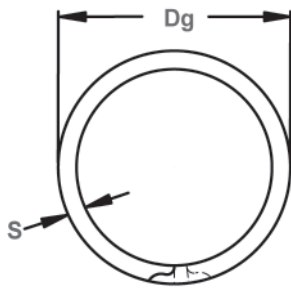

Free Diameter & Ring Measurements

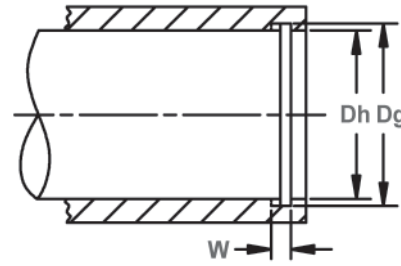
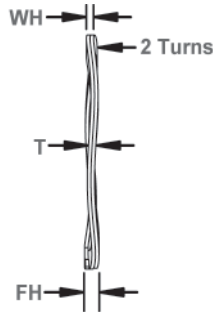

Shaft Diameter & Groove Dimensions

RING NO.	HOUSING DIAMETER	LOAD (lbs.) @ WORK HEIGHT	FREE HEIGHT (max.)	NUMBER OF WAVES	GROOVE SIZE		RING SIZE	
					DIAMETER	WIDTH	THICKNESS	SECTION
	Dh	WH	FH	Dg	W min.	T	S	
NKG-75	.750	25 @ .080	.114	3	.796	.119	.035	.065
NKG-87	.875	30 @ .085	.110	3	.931	.115	.042	.085
NKG-100	1.000	34 @ .085	.120	3	1.066	.125	.042	.085
NKG-112	1.125	38 @ .100	.125	3	1.197	.130	.050	.128
NKG-125	1.250	40 @ .100	.135	3	1.330	.140	.050	.128
NKG-137	1.375	45 @ .100	.125	4	1.461	.130	.050	.128
NKG-150	1.500	50 @ .100	.135	4	1.594	.140	.050	.128
NKG-162	1.625	55 @ .110	.135	4	1.725	.140	.062	.158
NKG-175	1.750	60 @ .110	.140	4	1.858	.145	.062	.158
NKG-187	1.875	63 @ .110	.141	4	1.989	.146	.062	.158
NKG-200	2.000	65 @ .110	.150	4	2.122	.155	.062	.158
NKG-212	2.125	70 @ .130	.170	4	2.251	.175	.078	.188
NKG-225	2.250	75 @ .130	.175	4	2.382	.180	.078	.188
NKG-237	2.375	80 @ .130	.180	4	2.517	.185	.078	.188
NKG-250	2.500	84 @ .130	.183	4	2.648	.188	.078	.188
NKG-262	2.625	88 @ .170	.220	4	2.781	.225	.093	.225
NKG-275	2.750	94 @ .170	.229	4	2.914	.234	.093	.225
NKG-287	2.875	97 @ .170	.225	4	3.051	.230	.093	.225
NKG-300	3.000	100 @ .170	.230	4	3.182	.235	.093	.225
NKG-312	3.125	103 @ .185	.250	4	3.315	.255	.111	.281
NKG-325	3.250	106 @ .185	.250	4	3.446	.255	.111	.281
NKG-350	3.500	115 @ .185	.245	4	3.710	.250	.111	.281
NKG-362	3.625	117 @ .185	.250	4	3.841	.250	.111	.281
NKG-375	3.750	121 @ .185	.255	4	3.974	.260	.111	.312
NKG-387	3.875	126 @ .185	.260	4	4.107	.265	.111	.312
NKG-400	4.000	130 @ .185	.255	4	4.240	.260	.111	.312
NKG-412	4.125	134 @ .185	.258	4	4.365	.263	.111	.312
NKG-425	4.250	140 @ .185	.264	4	4.490	.269	.111	.312
NKG-450	4.500	150 @ .185	.250	5	4.740	.255	.111	.312
NKG-475	4.750	160 @ .185	.252	5	4.995	.257	.111	.312
NKG-500	5.000	170 @ .185	.247	5	5.260	.252	.111	.312

NOTE: SIZES -312 THRU -500 ARE CRIMPED.



## External, Spiral, Inch

The waves in this spiral ring compensate for accumulated tolerances.

# NCG TruWave® Shaft Ring

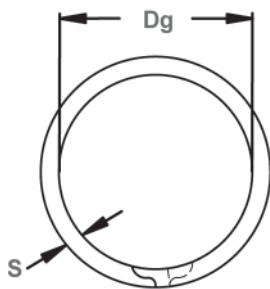

Free Diameter & Ring Measurements

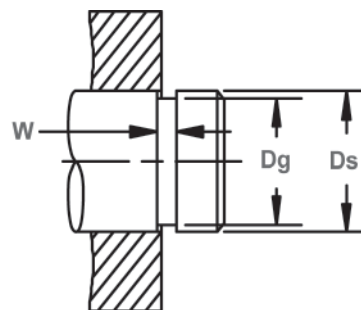
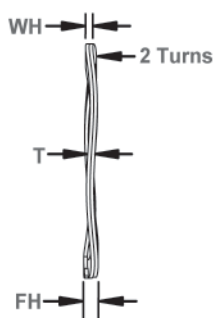

Shaft Diameter & Groove Dimensions

RING NO.	SHAFT DIAMETER	LOAD (lbs.) @ WORK HEIGHT	FREE HEIGHT (max.)	NUMBER OF WAVES	GROOVE SIZE		RING SIZE	
					DIAMETER	WIDTH	THICKNESS	SECTION
					Ds	WH	FH	Dg
NCG-75	.750	25 @ .085	.115	3	.704	.120	.042	.065
NCG-87	.875	30 @ .085	.131	3	.821	.136	.042	.075
NCG-100	1.000	34 @ .085	.129	3	.940	.134	.042	.085
NCG-112	1.125	38 @ .100	.137	3	1.059	.142	.050	.128
NCG-125	1.250	40 @ .100	.145	3	1.176	.150	.050	.128
NCG-137	1.375	45 @ .100	.130	4	1.291	.135	.050	.128
NCG-150	1.500	50 @ .100	.126	4	1.406	.131	.050	.128
NCG-162	1.625	55 @ .110	.138	4	1.529	.143	.062	.158
NCG-175	1.750	60 @ .110	.137	4	1.650	.142	.062	.158
NCG-187	1.875	63 @ .110	.140	4	1.769	.145	.062	.158
NCG-200	2.000	65 @ .110	.145	4	1.886	.150	.062	.158
NCG-212	2.125	70 @ .130	.170	4	2.003	.175	.078	.188
NCG-225	2.250	75 @ .130	.175	4	2.120	.180	.078	.188
NCG-237	2.375	80 @ .130	.175	4	2.239	.180	.078	.188
NCG-250	2.500	84 @ .130	.171	4	2.360	.176	.078	.188
NCG-262	2.625	88 @ .130	.181	4	2.481	.190	.078	.188
NCG-275	2.750	94 @ .170	.217	4	2.602	.222	.093	.225
NCG-287	2.875	97 @ .170	.217	4	2.721	.222	.093	.225
NCG-300	3.000	100 @ .170	.225	4	2.838	.230	.093	.225
NCG-312	3.125	103 @ .170	.230	4	2.957	.235	.093	.225
NCG-325	3.250	106 @ .170	.225	4	3.076	.230	.093	.225
NCG-350	3.500	115 @ .185	.245	4	3.316	.250	.111	.281
NCG-362	3.625	117 @ .185	.250	4	3.435	.255	.111	.281
NCG-375	3.750	121 @ .185	.258	4	3.552	.263	.111	.281
NCG-387	3.875	126 @ .185	.255	4	3.673	.260	.111	.281
NCG-400	4.000	130 @ .185	.268	4	3.792	.273	.111	.281
NCG-412	4.125	134 @ .185	.263	4	3.919	.268	.111	.281
NCG-425	4.250	140 @ .185	.248	5	4.065	.253	.111	.281
NCG-450	4.500	150 @ .185	.256	5	4.310	.261	.111	.281
NCG-475	4.750	160 @ .185	.253	5	4.550	.258	.111	.281
NCG-500	5.000	170 @ .185	.259	5	4.790	.264	.111	.281

NOTE: SIZES -275 THRU -500 ARE CRIMPED.





# SST Wave Springs

## Single Turn, Inch

Ideal for short deflection applications with low to medium forces. Offered in a number of waves and material thicknesses. Designed for a wide range of bore and rod diameters.

### Wave Spring Measurements

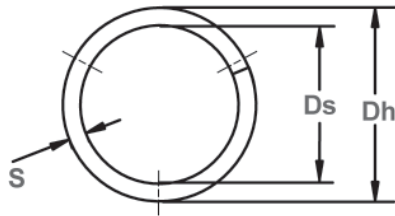

Overlap: Sizes -50 to -162  
3 Waves

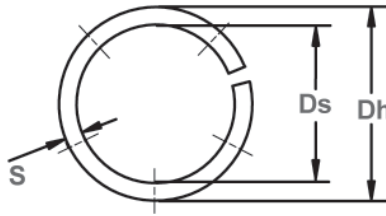

Gap: Sizes -175 & up  
\*Multiple Waves  
(see table)

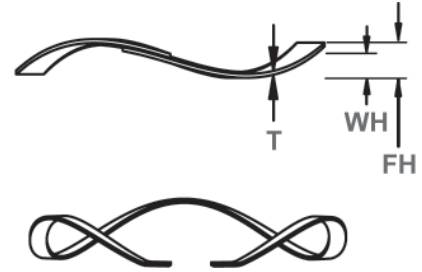

Optional End Design  
(Patent Pending)

WAVE SPRING NO.	OPERATES IN HOUSING DIAMETER	SHAFT DIAMETER CLEARANCE	LOAD (lb)	WORK HEIGHT	FREE HEIGHT Ref.	NO. OF WAVES*	THICKNESS	SECTION	SPRING RATE Ref. Lb/in.
	Dh	Ds		WH	FH		T	S	
SST-50	.500	.400	7	.050	.085	3	.008	.040	200
SST-62	.625	.480	10	.050	.095	3	.010	.058	222
SST-75	.750	.500	14	.062	.160	3	.010	.078	143
SST-87	.875	.620	16	.062	.130	3	.012	.094	235
SST-100	1.000	.780	18	.062	.160	3	.012	.094	184
SST-112	1.125	.840	20	.078	.130	3	.016	.133	385
SST-125	1.250	.960	22	.078	.150	3	.016	.133	306
SST-137	1.375	1.090	24	.078	.190	3	.016	.133	214
SST-150	1.500	1.170	26	.078	.170	3	.018	.143	283
SST-162	1.625	1.310	28	.078	.200	3	.018	.143	230
SST-175	1.750	1.440	30	.078	.140	4	.018	.143	484
SST-187	1.875	1.560	32	.078	.150	4	.018	.143	444
SST-200	2.000	1.680	34	.093	.140	4	.024	.150	723
SST-212	2.125	1.800	36	.093	.150	4	.024	.150	632
SST-225	2.250	1.930	38	.093	.170	4	.024	.150	494
SST-237	2.375	1.990	40	.093	.160	4	.024	.178	597
SST-250	2.500	2.120	42	.093	.170	4	.024	.178	545
SST-262	2.625	2.240	44	.093	.190	4	.024	.178	454
SST-275	2.750	2.340	46	.109	.170	4	.030	.188	754
SST-287	2.875	2.470	48	.109	.180	4	.030	.188	676
SST-300	3.000	2.590	50	.109	.190	4	.030	.188	617
SST-312	3.125	2.710	52	.109	.210	4	.030	.188	515
SST-325	3.250	2.750	54	.109	.200	4	.030	.233	593
SST-337	3.375	2.840	56	.109	.220	4	.030	.233	505
SST-350	3.500	3.000	58	.109	.230	4	.030	.233	479
SST-362	3.625	3.120	60	.109	.240	4	.030	.233	458
SST-375	3.750	3.250	62	.109	.260	4	.030	.233	411
SST-387	3.875	3.370	64	.109	.300	4	.030	.233	335
SST-400	4.000	3.500	66	.109	.190	5	.030	.233	815
SST-412	4.125	3.620	67	.109	.200	5	.030	.233	736
SST-425	4.250	3.740	69	.109	.210	5	.030	.233	683
SST-437	4.375	3.860	70	.109	.210	5	.030	.233	693
SST-450	4.500	3.990	72	.109	.230	5	.030	.233	595
SST-462	4.625	4.110	73	.125	.270	5	.030	.233	503
SST-475	4.750	4.240	75	.125	.310	5	.030	.233	405
SST-487	4.875	4.370	76	.125	.290	5	.030	.233	461

Wave Spring Measurements

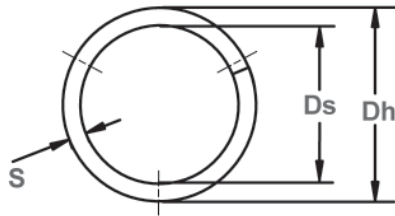

Overlap: Sizes -50 to -162  
3 Waves

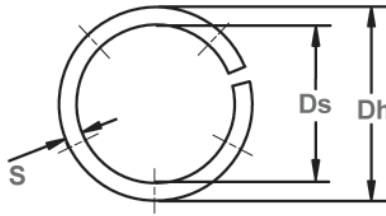

Gap: Sizes -175 & up  
\*Multiple Waves  
(see table)

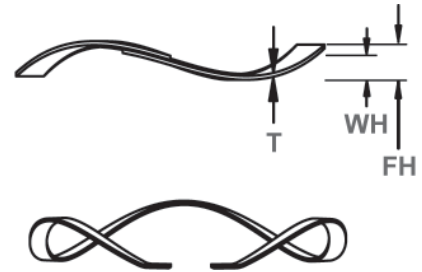

Optional End Design  
(Patent Pending)

WAVE SPRING NO.	OPERATES IN HOUSING DIAMETER	SHAFT DIAMETER CLEARANCE	LOAD (lb)	WORK HEIGHT	FREE HEIGHT Ref.	NO. OF WAVES*	THICKNESS	SECTION	SPRING RATE Ref. Lb/in.
	Dh	Ds		WH	FH		T	S	
SST-500	5.000	4.490	78	.125	.310	5	.030	.233	422
SST-512	5.125	4.610	80	.125	.340	5	.030	.233	372
SST-525	5.250	4.740	82	.125	.370	5	.030	.233	335
SST-537	5.375	4.860	84	.125	.380	5	.030	.233	329
SST-550	5.500	4.990	86	.125	.250	6	.030	.233	688
SST-562	5.625	5.110	88	.125	.270	6	.030	.233	607
SST-575	5.750	5.240	90	.125	.280	6	.030	.233	581
SST-587	5.875	5.360	92	.125	.300	6	.030	.233	526
SST-600	6.000	5.490	94	.125	.300	6	.030	.233	537
SST-612	6.125	5.610	96	.125	.310	6	.030	.233	519
SST-625	6.250	5.730	98	.125	.340	6	.030	.233	456
SST-637	6.375	5.860	100	.125	.350	6	.030	.233	444
SST-650	6.500	5.980	102	.125	.390	6	.030	.233	385
SST-675	6.750	6.230	104	.125	.420	6	.030	.233	353
SST-700	7.000	6.160	106	.156	.320	6	.032	.375	646
SST-725	7.250	6.440	108	.156	.350	6	.032	.375	557
SST-750	7.500	6.690	110	.156	.360	6	.032	.375	539
SST-775	7.750	6.940	114	.156	.380	6	.032	.375	509
SST-800	8.000	7.190	118	.156	.390	6	.032	.375	504
SST-825	8.250	7.440	122	.156	.430	6	.032	.375	445
SST-850	8.500	7.680	126	.156	.340	7	.032	.375	685
SST-875	8.750	7.930	130	.156	.340	7	.032	.375	707
SST-900	9.000	8.180	134	.156	.290	8	.032	.375	1,000
SST-950	9.500	8.680	142	.156	.240	9	.032	.375	1,690
SST-1000	10.000	9.170	150	.156	.290	9	.032	.375	1,119
SST-1050	10.500	9.670	158	.156	.310	9	.032	.375	1,026
SST-1100	11.000	10.170	166	.156	.350	9	.032	.375	856
SST-1150	11.500	10.660	174	.156	.360	9	.032	.375	853
SST-1200	12.000	11.160	182	.156	.440	9	.032	.375	641
SST-1250	12.500	11.660	190	.156	.350	10	.032	.375	979
SST-1300	13.000	12.160	198	.156	.410	10	.032	.375	780
SST-1350	13.500	12.650	206	.156	.430	10	.032	.375	752
SST-1400	14.000	13.150	214	.156	.300	12	.032	.375	1,486
SST-1450	14.500	13.650	221	.156	.320	12	.032	.375	1,348
SST-1500	15.000	14.130	230	.156	.350	12	.032	.375	1,186
SST-1550	15.500	14.640	239	.156	.310	13	.032	.375	1,552
SST-1600	16.000	15.140	248	.156	.340	13	.032	.375	1,348



# NST Wave Springs

**Single Turn, Narrow, Inch**

Ideal for short deflection applications where space is minimal.

## Wave Spring Measurements

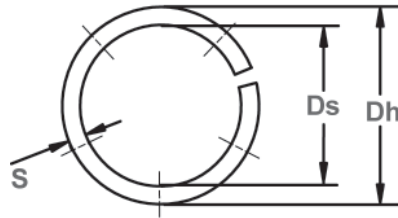

Gap Type  
\*Multiple Waves  
(see table)

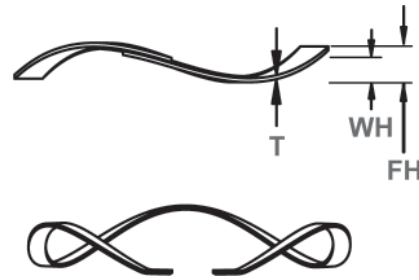

Optional End Design  
(Patent Pending)

WAVE SPRING NO.	OPERATES IN HOUSING DIAMETER		SHAFT DIAMETER CLEARANCE	LOAD (lb)	WORK HEIGHT		FREE HEIGHT Ref.	NO. OF WAVES*	THICKNESS	SECTION	SPRING RATE Ref. Lb/in.
	Dh	Ds			WH	FH			T	S	
NST-325	3.250	2.820		54	.109	.200	4	.03	.188	593	
NST-337	3.375	2.940		56	.109	.220	4	.03	.188	505	
NST-350	3.500	3.070		58	.109	.260	4	.03	.188	384	
NST-362	3.625	3.190		60	.109	.270	4	.03	.188	373	
NST-375	3.750	3.320		62	.109	.280	4	.03	.188	363	
NST-387	3.875	3.440		64	.109	.310	4	.03	.188	318	
NST-400	4.000	3.570		66	.109	.200	5	.03	.188	725	
NST-412	4.125	3.690		67	.109	.200	5	.03	.188	736	
NST-425	4.250	3.820		69	.109	.240	5	.03	.188	527	
NST-437	4.375	3.940		70	.109	.210	5	.03	.188	693	
NST-450	4.500	4.070		72	.109	.280	5	.03	.188	421	
NST-462	4.625	4.190		73	.125	.270	5	.03	.188	503	
NST-475	4.750	4.320		75	.125	.320	5	.03	.188	385	
NST-487	4.875	4.440		76	.125	.320	5	.03	.188	390	
NST-500	5.000	4.570		78	.125	.350	5	.03	.188	347	
NST-512	5.125	4.690		80	.125	.350	5	.03	.188	356	
NST-525	5.250	4.820		82	.125	.360	5	.03	.188	349	
NST-537	5.375	4.940		84	.125	.440	5	.03	.188	267	
NST-550	5.500	5.070		86	.125	.280	6	.03	.188	555	
NST-562	5.625	5.190		88	.125	.290	6	.03	.188	533	
NST-575	5.750	5.320		90	.125	.340	6	.03	.188	419	
NST-587	5.875	5.440		92	.125	.340	6	.03	.188	428	
NST-600	6.000	5.570		94	.125	.340	6	.03	.188	437	
NST-612	6.125	5.690		96	.125	.280	7	.03	.188	619	
NST-625	6.250	5.820		98	.125	.280	7	.03	.188	632	
NST-637	6.375	5.940		100	.125	.300	7	.03	.188	571	
NST-650	6.500	6.070		102	.125	.300	7	.03	.188	583	
NST-675	6.750	6.320		104	.125	.300	7	.03	.188	594	
NST-700	7.000	6.480		106	.156	.320	7	.03	.233	646	
NST-725	7.250	6.730		108	.156	.330	7	.03	.233	621	
NST-750	7.500	6.980		110	.156	.360	7	.03	.233	539	
NST-775	7.750	7.230		114	.156	.380	7	.03	.233	509	

# Single Turn, Metric

Ideal for short deflection applications with low to medium forces. Offered in a number of waves and material thicknesses. Designed for a wide range of bore and rod diameters.

# MST Wave Springs



## Wave Spring Measurements

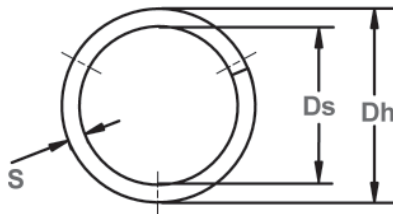

Overlap: Sizes -35 to -374  
3 Waves

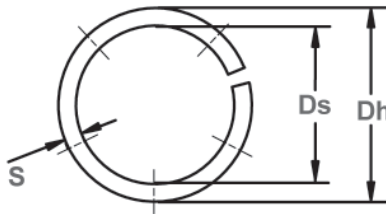

Gap: Sizes -394 & up  
\*Multiple Waves  
(see table)

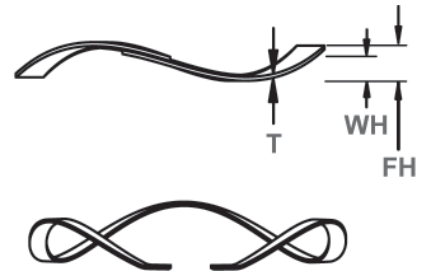

Optional End Design  
(Patent Pending)

WAVE SPRING NO.	CLINGS IN HOUSING DIAMETER	SHAFT DIAMETER CLEARANCE	LOAD (N)	WORK HEIGHT	FREE HEIGHT Ref.	NO. OF WAVES*	THICKNESS	SECTION	SPRING RATE Ref. N/mm
	Dh	Ds		WH	FH		T	S	
MST-35	9.0	6.86	25.8	1.00	1.50	3	0.20	0.81	52
MST-39	10.0	7.49	27.6	1.00	1.57	3	0.20	1.02	48
MST-43	11.0	8.46	29.4	1.00	1.83	3	0.20	1.02	35
MST-47	12.0	9.17	33.4	1.00	1.57	3	0.25	1.17	59
MST-51	13.0	9.53	37.8	1.00	1.57	3	0.25	1.47	66
MST-63	16.0	11.28	44.5	1.57	2.29	3	0.25	1.98	65
MST-75	19.0	14.28	53.4	1.57	3.05	3	0.25	1.98	35
MST-87	22.0	16.46	62.3	1.57	2.79	3	0.30	2.39	48
MST-95	24.0	18.46	66.7	1.57	3.56	3	0.30	2.39	35
MST-102	26.0	18.22	71.2	1.98	2.54	3	0.41	3.38	111
MST-110	28.0	20.22	75.6	1.98	2.79	3	0.41	3.38	85
MST-118	30.0	22.22	84.5	1.98	3.30	3	0.41	3.38	66
MST-126	32.0	24.22	89.0	1.98	3.81	3	0.41	3.38	52
MST-138	35.0	27.22	97.9	1.98	4.57	3	0.41	3.38	38
MST-146	37.0	28.72	102.3	1.98	3.81	3	0.46	3.63	58
MST-158	40.0	31.72	111.2	1.98	5.08	3	0.46	3.63	37
MST-165	42.0	33.72	115.7	1.98	3.05	4	0.46	3.63	99
MST-185	47.0	38.72	129.0	1.98	3.81	4	0.46	3.63	68
MST-205	52.0	43.11	142.4	2.36	3.56	4	0.61	3.81	121
MST-217	55.0	46.11	151.3	2.36	3.81	4	0.61	3.81	100
MST-244	62.0	51.69	169.1	2.36	4.32	4	0.61	4.52	85
MST-268	68.0	57.17	186.9	2.77	4.32	4	0.76	4.78	131
MST-276	70.0	59.17	191.3	2.77	4.32	4	0.76	4.78	119
MST-284	72.0	61.17	195.8	2.77	4.57	4	0.76	4.78	108
MST-295	75.0	64.17	204.7	2.77	5.08	4	0.76	4.78	94
MST-315	80.0	68.66	218.0	2.77	5.59	4	0.76	4.78	76
MST-335	85.0	71.38	231.4	2.77	5.59	4	0.76	5.92	83
MST-354	90.0	76.38	249.2	2.77	6.35	4	0.76	5.92	68
MST-374	95.0	81.38	262.5	2.77	7.37	4	0.76	5.92	57
MST-394	100.0	86.38	275.9	2.77	4.57	5	0.76	5.92	157
MST-413	105.0	91.38	289.2	2.77	5.08	5	0.76	5.92	134
MST-433	110.0	96.38	302.6	2.77	5.33	5	0.76	5.92	115
MST-453	115.0	101.38	315.9	3.18	6.35	5	0.76	5.92	99
MST-472	120.0	106.38	329.3	3.18	7.11	5	0.76	5.92	86
MST-492	125.0	111.38	342.6	3.18	7.62	5	0.76	5.92	76
MST-512	130.0	116.38	356.0	3.18	8.64	5	0.76	5.92	67
MST-532	135.0	121.38	369.3	3.18	9.40	5	0.76	5.92	59
MST-551	140.0	126.38	382.7	3.18	6.86	6	0.76	5.92	108
MST-571	145.0	131.38	396.0	3.18	7.37	6	0.76	5.92	97
MST-591	150.0	136.38	404.9	3.18	7.87	6	0.76	5.92	87
MST-630	160.0	146.38	440.5	3.18	9.40	6	0.76	5.92	71
MST-650	165.0	151.38	453.9	3.18	10.41	6	0.76	5.92	64
MST-669	170.0	156.38	467.2	3.18	11.18	6	0.76	5.92	58

ALL DIMENSIONS IN MILLIMETERS UNLESS OTHERWISE STATED.





# MST Wave Springs

## Single Turn, Metric

Ideal for short deflection applications with low to medium forces. Offered in a number of waves and material thicknesses. Designed for a wide range of bore and rod diameters.

### Wave Spring Measurements

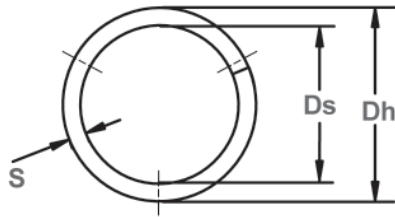

Overlap: Sizes -35 to -374  
3 Waves

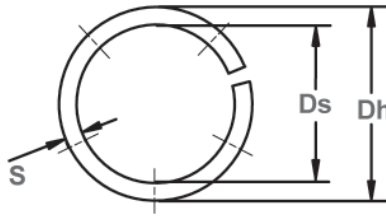

Gap: Sizes -394 & up  
\*Multiple Waves  
(see table)

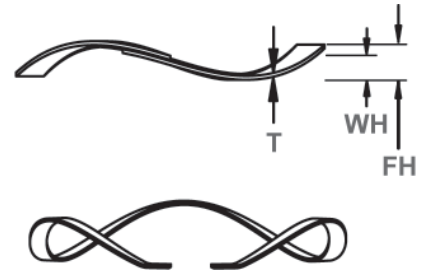

Optional End Design  
(Patent Pending)

WAVE SPRING NO.	CLINGS IN HOUSING DIAMETER	SHAFT DIAMETER CLEARANCE	LOAD (N)	WORK HEIGHT	FREE HEIGHT Ref.	NO. OF WAVES*	THICKNESS	SECTION	SPRING RATE Ref. N/mm
	Dh	Ds		WH	FH		T	S	
MST-689	175.0	154.16	480.6	3.96	8.13	6	0.81	9.53	116
MST-709	180.0	159.16	493.9	3.96	8.64	6	0.81	9.53	105
MST-728	185.0	164.16	507.3	3.96	9.14	6	0.81	9.53	97
MST-748	190.0	169.16	520.6	3.96	9.91	6	0.81	9.53	88
MST-787	200.0	179.16	547.3	3.96	7.11	7	0.81	9.53	174
MST-807	205.0	184.16	560.7	3.96	7.37	7	0.81	9.53	161
MST-827	210.0	189.16	578.5	3.96	7.87	7	0.81	9.53	149
MST-847	215.0	194.16	591.8	3.96	8.38	7	0.81	9.53	138
MST-866	220.0	199.16	605.2	3.96	8.64	7	0.81	9.53	128
MST-886	225.0	204.16	618.5	3.96	7.11	8	0.81	9.53	203
MST-906	230.0	209.16	631.9	3.96	6.10	9	0.81	9.53	303
MST-925	235.0	214.16	645.2	3.96	6.35	9	0.81	9.53	283
MST-945	240.0	219.16	658.6	3.96	6.35	9	0.81	9.53	265
MST-984	250.0	229.16	685.3	3.96	6.86	9	0.81	9.53	232
MST-1024	260.0	239.16	712.0	3.96	7.37	9	0.81	9.53	205
MST-1043	265.0	244.16	725.3	3.96	7.62	9	0.81	9.53	193
MST-1063	270.0	249.16	743.1	3.96	8.13	9	0.81	9.53	182
MST-1102	280.0	259.16	769.8	3.96	8.64	9	0.81	9.53	162
MST-1142	290.0	269.16	796.5	3.96	9.40	9	0.81	9.53	144
MST-1181	300.0	279.16	823.2	3.96	10.41	9	0.81	9.53	129
MST-1221	310.0	289.16	849.9	3.96	7.11	9	1.07	9.53	264
MST-1260	320.0	299.16	876.6	3.96	7.62	9	1.07	9.53	239
MST-1339	340.0	319.16	934.5	3.96	8.64	9	1.07	9.53	198
MST-1378	350.0	329.16	961.1	3.96	9.40	9	1.07	9.53	180
MST-1417	360.0	339.16	987.9	3.96	7.62	10	1.07	9.53	271
MST-1457	370.0	349.16	1014.6	3.96	8.13	10	1.07	9.53	249
MST-1496	380.0	359.16	1041.3	3.96	8.64	10	1.07	9.53	229
MST-1535	390.0	369.16	1072.4	3.96	9.14	10	1.07	9.53	211
MST-1575	400.0	379.16	1099.1	3.96	9.65	10	1.07	9.53	196
MST-1614	410.0	382.82	1125.8	3.96	8.38	10	1.07	12.70	251
MST-1654	420.0	392.82	1152.5	3.96	8.89	10	1.07	12.70	233
MST-1693	430.0	402.82	1179.2	3.96	7.62	11	1.07	12.70	317
MST-1732	440.0	412.82	1205.9	3.96	8.13	11	1.07	12.70	295
MST-1811	460.0	432.82	1263.7	3.96	8.89	11	1.07	12.70	256
MST-1890	480.0	452.82	1317.1	3.96	8.13	12	1.07	12.70	318
MST-1969	500.0	472.82	1370.5	3.96	8.89	12	1.07	12.70	280
MST-2126	540.0	512.82	1481.8	3.96	8.89	13	1.07	12.70	303
MST-2284	580.0	552.82	1593.0	3.96	8.89	14	1.07	12.70	327

ALL DIMENSIONS IN MILLIMETERS UNLESS OTHERWISE STATED.

# Bearing Interchange Chart

This chart pairs metric single turn wave springs with the appropriate standard bearing number.



## Wave Spring Measurements

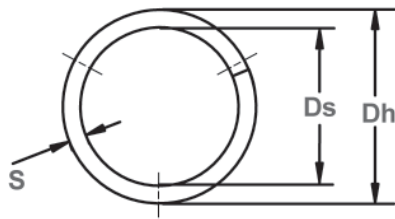

Overlap: Sizes -35 to -374  
3 Waves

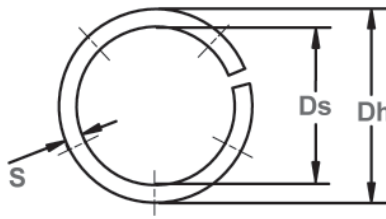

Gap: Sizes -394 & up  
\*Multiple Waves  
(see table)

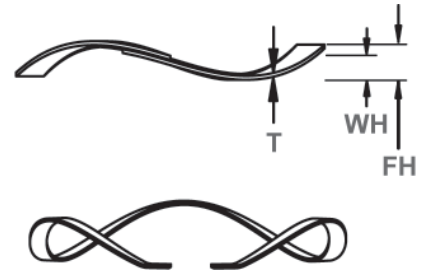

Optional End Design  
(Patent Pending)

WAVE SPRING NO.	BEARING O.D. (mm)	BEARING NUMBERS						
		EXTRA SMALL	EXTREMELY LIGHT	EXTRA LIGHT	NARROW	LIGHT	MEDIUM	HEAVY
MST-35	9	03,18/4						
MST-39	10	23						
MST-43	11	18/5,19,4						
MST-47	12	4						
MST-51	13	18/6,19/5,24,33						
MST-63	16	34	-	-	-	-	-	-
MST-75	19	35,36	-	-	-	-	-	-
MST-87	22	37,38	00	-	-	-	-	-
MST-95	24	38KV	01	-	-	-	-	-
MST-102	26	39	-	100	-	-	-	-
MST-110	28	-	02	101	-	-	-	-
MST-118	30	-	03	-	200	-	-	-
MST-126	32	-	-	102	02	201	-	-
MST-138	35	-	-	103	-	202	300	-
MST-146	37	-	04	-	03	-	301	-
MST-158	40	-	-	-	-	203	-	-
MST-165	42	-	05	104	04	-	302	-
MST-185	47	-	06	105	-	204	303	-
MST-205	52	-	-	-	05	205	304	-
MST-217	55	-	07	106	-	-	-	-
MST-244	62	-	08	107	06	206	305	403
MST-268	68	-	09	108	-	-	-	-
MST-276	70	-	-	-	07	-	-	-
MST-284	72	-	10	-	-	207	306	404
MST-295	75	-	-	109	-	-	-	-
MST-315	80	-	11	110	08	208	307	405
MST-335	85	-	12	-	09	209	-	-
MST-354	90	-	13	111	10	210	308	406
MST-374	95	-	-	112	-	-	-	-
MST-394	100	-	14	113	11	211	309	407
MST-413	105	-	15	-	12	-	-	-
MST-433	110	-	16	114	-	212	310	408
MST-453	115	-	-	115	13	-	-	-
MST-472	120	-	17	-	14	213	311	409
MST-492	125	-	18	116	-	214	-	-
MST-512	130	-	19	117	15	215	312	410
MST-532	135	-	-	-	16	-	-	-
MST-551	140	-	20	118	-	216	313	411
MST-571	145	-	21	119	17	-	-	-
MST-591	150	-	22	120	18	217	314	412
MST-630	160	-	-	121	19	218	315	413
MST-650	165	-	24	-	20	-	-	-
MST-669	170	-	-	122	-	219	316	-

WAVE SPRING NO.	BEARING O.D. (mm)	BEARING NUMBERS						
		EXTRA SMALL	EXTREMELY LIGHT	EXTRA LIGHT	NARROW	LIGHT	MEDIUM	HEAVY
MST-689	175	-	-	-	22	-	-	-
MST-709	180	-	26	124	21	220	317	414
MST-728	185	-	-	-	22	-	-	-
MST-748	190	-	28	-	24	221	318	415
MST-787	200	-	-	126	-	222	319	416
MST-807	205	-	-	-	26	-	-	-
MST-827	210	-	30	128	-	-	-	417
MST-847	215	-	-	-	-	224	320	-
MST-866	220	-	32	-	28	-	-	-
MST-886	225	-	-	130	-	-	321	418
MST-906	230	-	34	-	-	226	-	-
MST-925	235	-	-	-	30	-	-	-
MST-945	240	-	-	132	-	-	322	-
MST-984	250	-	36	-	32	228	-	419
MST-1024	260	-	38	134	-	-	324	-
MST-1043	265	-	-	-	34	-	-	420
MST-1063	270	-	-	-	-	230	-	-
MST-1102	280	-	40	136	36	-	326	-
MST-1142	290	-	-	138	-	232	-	421
MST-1181	300	-	-	-	38	-	328	-
MST-1221	310	-	-	140	-	234	-	-
MST-1260	320	-	-	-	40	236	330	422
MST-1339	340	-	-	144	42	238	332	-
MST-1378	350	-	-	-	44	-	-	-
MST-1417	360	-	-	148	-	240	334	-
MST-1457	370	-	-	-	46	-	-	-
MST-1496	380	-	-	-	-	-	336	-
MST-1535	390	-	-	-	48	-	-	-
MST-1575	400	-	-	152	-	244	338	-
MST-1614	410	-	-	-	50	-	-	-
MST-1654	420	-	-	156	-	-	340	-
MST-1693	430	-	-	-	52	-	-	-
MST-1732	440	-	-	-	-	248	342	-
MST-1811	460	-	-	160	56	-	344	-
MST-1890	480	-	-	164	-	252	-	-
MST-1969	500	-	-	-	64	256	348	-
MST-2126	540	-	-	-	-	260	352	-
MST-2284	580	-	-	-	-	264	356	-



# WSL, WSM, WSR Wave Springs

## Multi Turn, Inch

Used for low to medium force applications with greater travel compared to single-turn springs. Utilizes nearly half the space as helical compression springs while producing the same force.

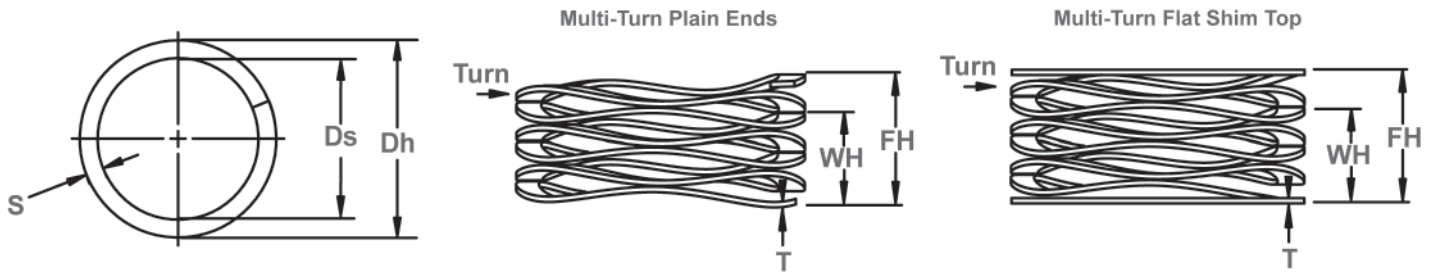

Wave Spring Measurements

WAVE SPRING NO.	PILOTS & OPERATES IN HOUSING DIAMETER			SHAFT DIAMETER CLEARANCE	LOAD (lbs.)	WORK HEIGHT	FREE HEIGHT Ref.	NUMBER OF WAVES	NUMBER OF TURNS	THICKNESS	SECTION	SPRING RATE Ref. Lb/in.
	Dh DEC	Dh FRAC	Dh mm							T	S	
				Ds		WH	FH					
WSL-25 A*	.250	1/4	6.4	.150	2	.033	.075	2.5	3	.006	.024	48
WSL-25 B*	.250	1/4	6.4	.150	2	.050	.100	2.5	4	.006	.024	40
WSL-25 C*	.250	1/4	6.4	.150	2	.060	.125	2.5	5	.006	.024	31
WSL-25 D*	.250	1/4	6.4	.150	2	.075	.150	2.5	6	.006	.024	27
WSL-25 E*	.250	1/4	6.4	.150	2	.085	.175	2.5	7	.006	.024	22
WSL-25 F*	.250	1/4	6.4	.150	2	.095	.200	2.5	8	.006	.024	19
WSL-25 G*	.250	1/4	6.4	.150	2	.120	.225	2.5	9	.006	.024	19
WSL-25 H*	.250	1/4	6.4	.150	2	.140	.275	2.5	11	.006	.024	15
WSL-25 I*	.250	1/4	6.4	.150	2	.170	.325	2.5	13	.006	.024	13
WSM-25 A*	.250	1/4	6.4	.150	5	.037	.075	2.5	3	.008	.024	132
WSM-25 B*	.250	1/4	6.4	.150	5	.048	.100	2.5	4	.008	.024	96
WSM-25 C*	.250	1/4	6.4	.150	5	.065	.125	2.5	5	.008	.024	83
WSM-25 D*	.250	1/4	6.4	.150	5	.075	.150	2.5	6	.008	.024	67
WSM-25 E*	.250	1/4	6.4	.150	5	.090	.175	2.5	7	.008	.024	59
WSM-25 F*	.250	1/4	6.4	.150	5	.100	.200	2.5	8	.008	.024	50
WSM-25 G*	.250	1/4	6.4	.150	5	.120	.225	2.5	9	.008	.024	48
WSM-25 H*	.250	1/4	6.4	.150	5	.148	.275	2.5	11	.008	.024	39
WSM-25 I*	.250	1/4	6.4	.150	5	.175	.325	2.5	13	.008	.024	33
WSL-31 A	.312	5/16	7.9	.200	3	.070	.114	2.5	3	.008	.032	68
WSL-31 B	.312	5/16	7.9	.200	3	.096	.152	2.5	4	.008	.032	54
WSL-31 C	.312	5/16	7.9	.200	3	.118	.190	2.5	5	.008	.032	42
WSL-31 D	.312	5/16	7.9	.200	3	.145	.228	2.5	6	.008	.032	36
WSL-31 E	.312	5/16	7.9	.200	3	.165	.266	2.5	7	.008	.032	30
WSL-31 F	.312	5/16	7.9	.200	3	.195	.304	2.5	8	.008	.032	28
WSL-31 G	.312	5/16	7.9	.200	3	.215	.342	2.5	9	.008	.032	24
WSL-31 H	.312	5/16	7.9	.200	3	.262	.418	2.5	11	.008	.032	19
WSL-31 I	.312	5/16	7.9	.200	3	.309	.494	2.5	13	.008	.032	16
WSM-31 A	.312	5/16	7.9	.200	6	.072	.114	2.5	3	.010	.032	143
WSM-31 B	.312	5/16	7.9	.200	6	.096	.152	2.5	4	.010	.032	107
WSM-31 C	.312	5/16	7.9	.200	6	.123	.190	2.5	5	.010	.032	90
WSM-31 D	.312	5/16	7.9	.200	6	.144	.228	2.5	6	.010	.032	71
WSM-31 E	.312	5/16	7.9	.200	6	.176	.266	2.5	7	.010	.032	67
WSM-31 F	.312	5/16	7.9	.200	6	.197	.304	2.5	8	.010	.032	56
WSM-31 G	.312	5/16	7.9	.200	6	.227	.342	2.5	9	.010	.032	52
WSM-31 H	.312	5/16	7.9	.200	6	.278	.418	2.5	11	.010	.032	43
WSM-31 I	.312	5/16	7.9	.200	6	.336	.494	2.5	13	.010	.032	38

\*Not available with shim ends.

PART NUMBERS SHOWN REFLECT MULTI-TURN WAVE SPRINGS WITH PLAIN ENDS.

THE LETTERS SHOWN AFTER THE PART NUMBERS REPRESENT THE NUMBER OF TURNS. WHEN ORDERING, PARTS SHOULD BE PRESENTED WITH THE PART NUMBER, FOLLOWED BY THE MATERIAL, AND THEN THE NUMBER OF TURNS (i.e. WSL-37ST A, WSM-50ST B, WSR-75ST C, ETC.)

FOR FLAT SHIM TOP WAVE SPRINGS, ADD AN 'P' TO THE END OF THE PART NUMBER (i.e. WSL-37ST AP, WSM-50ST BP, WSR-75ST CP, ETC.)

MATERIAL CODES: ST = CARBON STEEL. SQ = 17-7 PH/C STAINLESS STEEL. SPECIAL ALLOYS AVAILABLE UPON REQUEST.



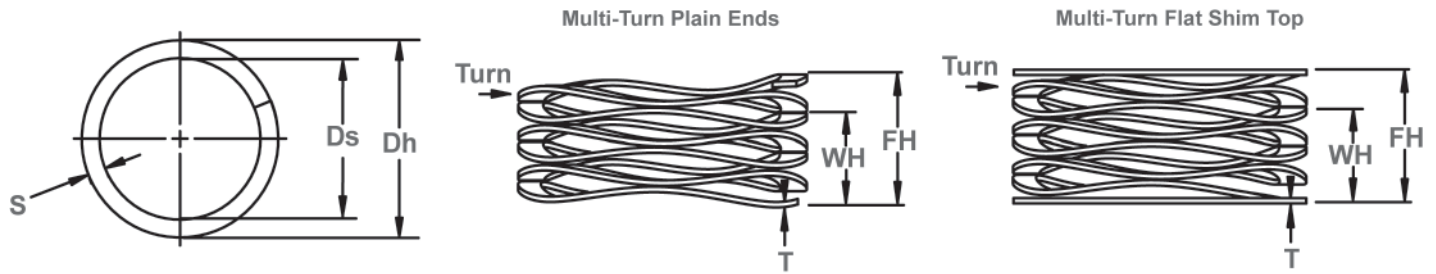

Wave Spring Measurements

WAVE SPRING NO.	PILOTS & OPERATES IN HOUSING DIAMETER			SHAFT DIAMETER CLEARANCE	LOAD (lbs.)	WORK HEIGHT	FREE HEIGHT Ref.	NUMBER OF WAVES	NUMBER OF TURNS	THICKNESS	SECTION	SPRING RATE Ref. Lb/in.
	Dh DEC	Dh FRAC	Dh mm							T	S	
				Ds		WH	FH					
WSL-37 A	.375	3/8	9.5	.250	4	.062	.150	2.5	3	.008	.032	45
WSL-37 B	.375	3/8	9.5	.250	4	.098	.200	2.5	4	.008	.032	39
WSL-37 C	.375	3/8	9.5	.250	4	.108	.250	2.5	5	.008	.032	28
WSL-37 D	.375	3/8	9.5	.250	4	.135	.300	2.5	6	.008	.032	24
WSL-37 E	.375	3/8	9.5	.250	4	.150	.350	2.5	7	.008	.032	20
WSL-37 F	.375	3/8	9.5	.250	4	.184	.400	2.5	8	.008	.032	19
WSL-37 G	.375	3/8	9.5	.250	4	.195	.450	2.5	9	.008	.032	16
WSL-37 H	.375	3/8	9.5	.250	4	.228	.500	2.5	10	.008	.032	15
WSL-37 I	.375	3/8	9.5	.250	4	.240	.550	2.5	11	.008	.032	13
WSM-37 A	.375	3/8	9.5	.250	7	.081	.150	2.5	3	.011	.032	101
WSM-37 B	.375	3/8	9.5	.250	7	.119	.200	2.5	4	.011	.032	86
WSM-37 C	.375	3/8	9.5	.250	7	.145	.250	2.5	5	.011	.032	67
WSM-37 D	.375	3/8	9.5	.250	7	.180	.300	2.5	6	.011	.032	58
WSM-37 E	.375	3/8	9.5	.250	7	.202	.350	2.5	7	.011	.032	47
WSM-37 F	.375	3/8	9.5	.250	7	.240	.400	2.5	8	.011	.032	44
WSM-37 G	.375	3/8	9.5	.250	7	.262	.450	2.5	9	.011	.032	37
WSM-37 H	.375	3/8	9.5	.250	7	.298	.500	2.5	10	.011	.032	35
WSM-37 I	.375	3/8	9.5	.250	7	.327	.550	2.5	11	.011	.032	31
WSL-43 A	.437	7/16	11.1	.281	4	.063	.165	2.5	3	.008	.040	39
WSL-43 B	.437	7/16	11.1	.281	4	.093	.220	2.5	4	.008	.040	31
WSL-43 C	.437	7/16	11.1	.281	4	.109	.275	2.5	5	.008	.040	24
WSL-43 D	.437	7/16	11.1	.281	4	.143	.330	2.5	6	.008	.040	21
WSL-43 E	.437	7/16	11.1	.281	4	.160	.385	2.5	7	.008	.040	18
WSL-43 F	.437	7/16	11.1	.281	4	.195	.440	2.5	8	.008	.040	16
WSL-43 G	.437	7/16	11.1	.281	4	.210	.495	2.5	9	.008	.040	14
WSL-43 H	.437	7/16	11.1	.281	4	.240	.550	2.5	10	.008	.040	13
WSL-43 I	.437	7/16	11.1	.281	4	.260	.605	2.5	11	.008	.040	12
WSM-43 A	.437	7/16	11.1	.281	8	.082	.165	2.5	3	.011	.046	96
WSM-43 B	.437	7/16	11.1	.281	8	.115	.220	2.5	4	.011	.046	76
WSM-43 C	.437	7/16	11.1	.281	8	.142	.275	2.5	5	.011	.046	60
WSM-43 D	.437	7/16	11.1	.281	8	.179	.330	2.5	6	.011	.046	53
WSM-43 E	.437	7/16	11.1	.281	8	.198	.385	2.5	7	.011	.046	43
WSM-43 F	.437	7/16	11.1	.281	8	.231	.440	2.5	8	.011	.046	38
WSM-43 G	.437	7/16	11.1	.281	8	.255	.495	2.5	9	.011	.046	33
WSM-43 H	.437	7/16	11.1	.281	8	.290	.550	2.5	10	.011	.046	31
WSM-43 I	.437	7/16	11.1	.281	8	.319	.605	2.5	11	.011	.046	28

PART NUMBERS SHOWN REFLECT MULTI-TURN WAVE SPRINGS WITH PLAIN ENDS.

THE LETTERS SHOWN AFTER THE PART NUMBERS REPRESENT THE NUMBER OF TURNS. WHEN ORDERING, PARTS SHOULD BE PRESENTED WITH THE PART NUMBER, FOLLOWED BY THE MATERIAL, AND THEN THE NUMBER OF TURNS (i.e. WSL-37ST A, WSM-50ST B, WSR-75ST C, ETC.)

FOR FLAT SHIM TOP WAVE SPRINGS, ADD AN 'P' TO THE END OF THE PART NUMBER (i.e. WSL-37ST AP, WSM-50ST BP, WSR-75ST CP, ETC.)

MATERIAL CODES: ST = CARBON STEEL. SQ = 17-7 PH/C STAINLESS STEEL. SPECIAL ALLOYS AVAILABLE UPON REQUEST.

# WSL, WSM, WSR Wave Springs

## Multi Turn, Inch

Used for low to medium force applications with greater travel compared to single-turn springs. Utilizes nearly half the space as helical compression springs while producing the same force.

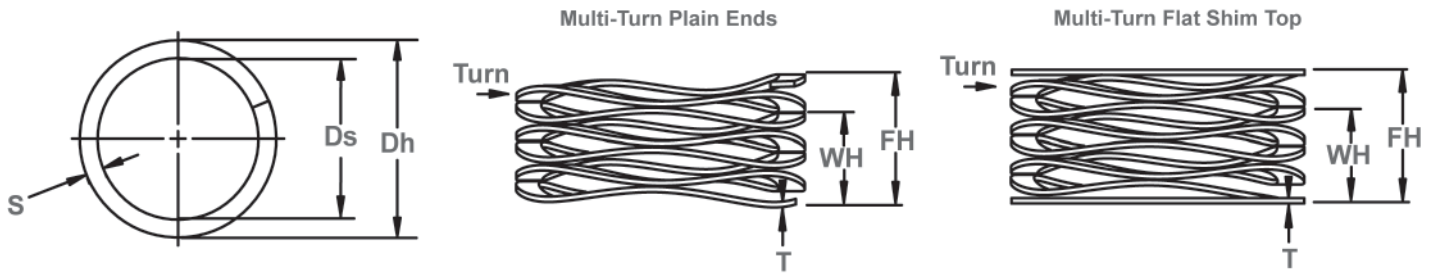

Wave Spring Measurements

WAVE SPRING NO.	PILOTS & OPERATES IN HOUSING DIAMETER			SHAFT DIAMETER CLEARANCE	LOAD (lbs.)	WORK HEIGHT	FREE HEIGHT Ref.	NUMBER OF WAVES	NUMBER OF TURNS	THICKNESS	SECTION	SPRING RATE Ref. Lb/in.
	Dh DEC	Dh FRAC	Dh mm									
				Ds		WH	FH			T	S	
WSL-50 A	.500	1/2	12.7	.312	5	.062	.180	2.5	3	.008	.056	42
WSL-50 B	.500	1/2	12.7	.312	5	.090	.240	2.5	4	.008	.056	33
WSL-50 C	.500	1/2	12.7	.312	5	.107	.300	2.5	5	.008	.056	26
WSL-50 D	.500	1/2	12.7	.312	5	.136	.360	2.5	6	.008	.056	22
WSL-50 E	.500	1/2	12.7	.312	5	.150	.420	2.5	7	.008	.056	19
WSL-50 F	.500	1/2	12.7	.312	5	.180	.480	2.5	8	.008	.056	17
WSL-50 G	.500	1/2	12.7	.312	5	.195	.540	2.5	9	.008	.056	14
WSL-50 H	.500	1/2	12.7	.312	5	.220	.600	2.5	10	.008	.056	13
WSL-50 I	.500	1/2	12.7	.312	5	.240	.660	2.5	11	.008	.056	12
WSM-50 A	.500	1/2	12.7	.312	10	.065	.180	2.5	3	.010	.058	87
WSM-50 B	.500	1/2	12.7	.312	10	.092	.240	2.5	4	.010	.058	68
WSM-50 C	.500	1/2	12.7	.312	10	.114	.300	2.5	5	.010	.058	54
WSM-50 D	.500	1/2	12.7	.312	10	.147	.360	2.5	6	.010	.058	47
WSM-50 E	.500	1/2	12.7	.312	10	.162	.420	2.5	7	.010	.058	39
WSM-50 F	.500	1/2	12.7	.312	10	.196	.480	2.5	8	.010	.058	35
WSM-50 G	.500	1/2	12.7	.312	10	.207	.540	2.5	9	.010	.058	30
WSM-50 H	.500	1/2	12.7	.312	10	.246	.600	2.5	10	.010	.058	28
WSM-50 I	.500	1/2	12.7	.312	10	.264	.660	2.5	11	.010	.058	25
WSL-56 A	.562	9/16	14.3	.375	5	.080	.195	2.5	3	.009	.058	43
WSL-56 B	.562	9/16	14.3	.375	5	.125	.260	2.5	4	.009	.058	37
WSL-56 C	.562	9/16	14.3	.375	5	.135	.325	2.5	5	.009	.058	26
WSL-56 D	.562	9/16	14.3	.375	5	.180	.390	2.5	6	.009	.058	24
WSL-56 E	.562	9/16	14.3	.375	5	.190	.455	2.5	7	.009	.058	19
WSL-56 F	.562	9/16	14.3	.375	5	.230	.520	2.5	8	.009	.058	17
WSL-56 G	.562	9/16	14.3	.375	5	.260	.585	2.5	9	.009	.058	15
WSL-56 H	.562	9/16	14.3	.375	5	.285	.650	2.5	10	.009	.058	14
WSL-56 I	.562	9/16	14.3	.375	5	.315	.715	2.5	11	.009	.058	13
WSM-56 A	.562	9/16	14.3	.375	11	.086	.195	2.5	3	.012	.060	101
WSM-56 B	.562	9/16	14.3	.375	11	.123	.260	2.5	4	.012	.060	80
WSM-56 C	.562	9/16	14.3	.375	11	.145	.325	2.5	5	.012	.060	61
WSM-56 D	.562	9/16	14.3	.375	11	.187	.390	2.5	6	.012	.060	54
WSM-56 E	.562	9/16	14.3	.375	11	.209	.455	2.5	7	.012	.060	45
WSM-56 F	.562	9/16	14.3	.375	11	.253	.520	2.5	8	.012	.060	41
WSM-56 G	.562	9/16	14.3	.375	11	.273	.585	2.5	9	.012	.060	35
WSM-56 H	.562	9/16	14.3	.375	11	.318	.650	2.5	10	.012	.060	33
WSM-56 I	.562	9/16	14.3	.375	11	.343	.715	2.5	11	.012	.060	30

PART NUMBERS SHOWN REFLECT MULTI-TURN WAVE SPRINGS WITH PLAIN ENDS.

THE LETTERS SHOWN AFTER THE PART NUMBERS REPRESENT THE NUMBER OF TURNS. WHEN ORDERING, PARTS SHOULD BE PRESENTED WITH THE PART NUMBER, FOLLOWED BY THE MATERIAL, AND THEN THE NUMBER OF TURNS (i.e. WSL-37ST A, WSM-50ST B, WSR-75ST C, ETC.)

FOR FLAT SHIM TOP WAVE SPRINGS, ADD AN 'P' TO THE END OF THE PART NUMBER (i.e. WSL-37ST AP, WSM-50ST BP, WSR-75ST CP, ETC.)

MATERIAL CODES: ST = CARBON STEEL. SQ = 17-7 PH/C STAINLESS STEEL. SPECIAL ALLOYS AVAILABLE UPON REQUEST.

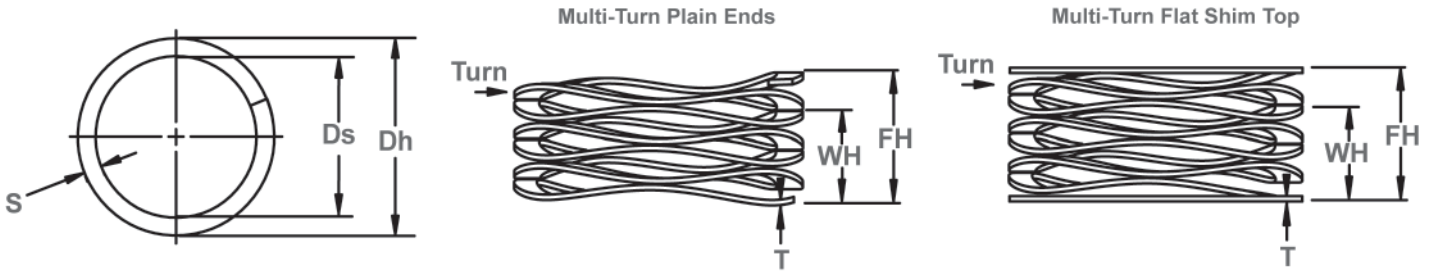

Wave Spring Measurements

WAVE SPRING NO.	PILOTS & OPERATES IN HOUSING DIAMETER			SHAFT DIAMETER CLEARANCE	LOAD (lbs.)	WORK HEIGHT	FREE HEIGHT Ref.	NUMBER OF WAVES	NUMBER OF TURNS	THICKNESS	SECTION	SPRING RATE Ref. Lb/in.
	Dh DEC	Dh FRAC	Dh mm									
						WH	FH			T	S	
WSL-62 A	.625	5/8	15.9	.450	6	.055	.180	2.5	3	.010	.058	48
WSL-62 B	.625	5/8	15.9	.450	6	.068	.240	2.5	4	.010	.058	35
WSL-62 C	.625	5/8	15.9	.450	6	.085	.300	2.5	5	.010	.058	28
WSL-62 D	.625	5/8	15.9	.450	6	.106	.360	2.5	6	.010	.058	24
WSL-62 E	.625	5/8	15.9	.450	6	.128	.420	2.5	7	.010	.058	21
WSL-62 F	.625	5/8	15.9	.450	6	.165	.540	2.5	9	.010	.058	16
WSL-62 G	.625	5/8	15.9	.450	6	.202	.660	2.5	11	.010	.058	13
WSL-62 H	.625	5/8	15.9	.450	6	.238	.780	2.5	13	.010	.058	11
WSM-62 A	.625	5/8	15.9	.450	12	.104	.180	3.5	3	.010	.058	158
WSM-62 B	.625	5/8	15.9	.450	12	.130	.240	3.5	4	.010	.058	109
WSM-62 C	.625	5/8	15.9	.450	12	.175	.300	3.5	5	.010	.058	96
WSM-62 D	.625	5/8	15.9	.450	12	.206	.360	3.5	6	.010	.058	78
WSM-62 E	.625	5/8	15.9	.450	12	.246	.420	3.5	7	.010	.058	69
WSM-62 F	.625	5/8	15.9	.450	12	.317	.540	3.5	9	.010	.058	54
WSM-62 G	.625	5/8	15.9	.450	12	.386	.660	3.5	11	.010	.058	44
WSM-62 H	.625	5/8	15.9	.450	12	.454	.780	3.5	13	.010	.058	37
WSL-75 A	.750	3/4	19.0	.550	7	.142	.250	3.5	3	.008	.071	65
WSL-75 B	.750	3/4	19.0	.550	7	.187	.333	3.5	4	.008	.071	48
WSL-75 C	.750	3/4	19.0	.550	7	.246	.417	3.5	5	.008	.071	41
WSL-75 D	.750	3/4	19.0	.550	7	.285	.500	3.5	6	.008	.071	33
WSL-75 E	.750	3/4	19.0	.550	7	.348	.583	3.5	7	.008	.071	30
WSL-75 F	.750	3/4	19.0	.550	7	.446	.750	3.5	9	.008	.071	23
WSL-75 G	.750	3/4	19.0	.550	7	.580	1.000	3.5	12	.008	.071	17
WSM-75 A	.750	3/4	19.0	.550	13	.159	.250	3.5	3	.010	.078	143
WSM-75 B	.750	3/4	19.0	.550	13	.203	.333	3.5	4	.010	.078	100
WSM-75 C	.750	3/4	19.0	.550	13	.270	.417	3.5	5	.010	.078	88
WSM-75 D	.750	3/4	19.0	.550	13	.314	.500	3.5	6	.010	.078	70
WSM-75 E	.750	3/4	19.0	.550	13	.381	.583	3.5	7	.010	.078	64
WSM-75 F	.750	3/4	19.0	.550	13	.489	.750	3.5	9	.010	.078	50
WSM-75 G	.750	3/4	19.0	.550	13	.649	1.000	3.5	12	.010	.078	37
WSR-75 A	.750	3/4	19.0	.550	22	.169	.250	3.5	3	.013	.079	272
WSR-75 B	.750	3/4	19.0	.550	22	.215	.333	3.5	4	.013	.079	186
WSR-75 C	.750	3/4	19.0	.550	22	.291	.417	3.5	5	.013	.079	175
WSR-75 D	.750	3/4	19.0	.550	22	.335	.500	3.5	6	.013	.079	133
WSR-75 E	.750	3/4	19.0	.550	22	.405	.583	3.5	7	.013	.079	124
WSR-75 F	.750	3/4	19.0	.550	22	.526	.750	3.5	9	.013	.079	98
WSR-75 G	.750	3/4	19.0	.550	22	.699	1.000	3.5	12	.013	.079	73

PART NUMBERS SHOWN REFLECT MULTI-TURN WAVE SPRINGS WITH PLAIN ENDS.

THE LETTERS SHOWN AFTER THE PART NUMBERS REPRESENT THE NUMBER OF TURNS. WHEN ORDERING, PARTS SHOULD BE PRESENTED WITH THE PART NUMBER, FOLLOWED BY THE MATERIAL, AND THEN THE NUMBER OF TURNS (i.e. WSL-37ST A, WSM-50ST B, WSR-75ST C, ETC.)

FOR FLAT SHIM TOP WAVE SPRINGS, ADD AN 'P' TO THE END OF THE PART NUMBER (i.e. WSL-37ST AP, WSM-50ST BP, WSR-75ST CP, ETC.)

MATERIAL CODES: ST = CARBON STEEL. SQ = 17-7 PH/C STAINLESS STEEL. SPECIAL ALLOYS AVAILABLE UPON REQUEST.

# WSL, WSM, WSR Wave Springs

## Multi Turn, Inch

Used for low to medium force applications with greater travel compared to single-turn springs. Utilizes nearly half the space as helical compression springs while producing the same force.

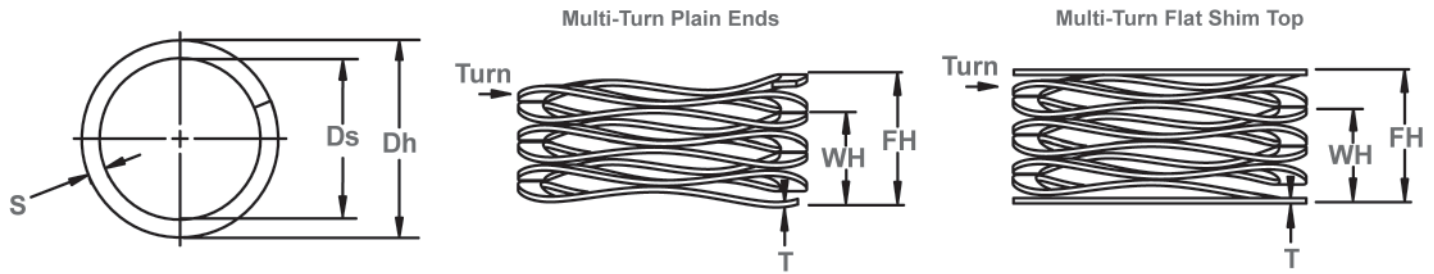

Wave Spring Measurements

WAVE SPRING NO.	PILOTS & OPERATES IN HOUSING DIAMETER			SHAFT DIAMETER CLEARANCE Ds	LOAD (lbs.)	WORK HEIGHT WH	FREE HEIGHT Ref. FH	NUMBER OF WAVES	NUMBER OF TURNS	THICKNESS T	SECTION S	SPRING RATE Ref. Lb/in.
	Dh DEC	Dh FRAC	Dh mm									
WSL-87 A	.875	7/8	22.2	.600	12	.117	.250	3.5	3	.010	.086	90
WSL-87 B	.875	7/8	22.2	.600	12	.158	.333	3.5	4	.010	.086	69
WSL-87 C	.875	7/8	22.2	.600	12	.207	.417	3.5	5	.010	.086	57
WSL-87 D	.875	7/8	22.2	.600	12	.242	.500	3.5	6	.010	.086	47
WSL-87 E	.875	7/8	22.2	.600	12	.287	.583	3.5	7	.010	.086	41
WSL-87 F	.875	7/8	22.2	.600	12	.378	.750	3.5	9	.010	.086	32
WSL-87 G	.875	7/8	22.2	.600	12	.498	1.000	3.5	12	.010	.086	24
WSM-87 A	.875	7/8	22.2	.600	18	.124	.250	3.5	3	.012	.094	148
WSM-87 B	.875	7/8	22.2	.600	18	.164	.333	3.5	4	.012	.094	108
WSM-87 C	.875	7/8	22.2	.600	18	.214	.417	3.5	5	.012	.094	89
WSM-87 D	.875	7/8	22.2	.600	18	.252	.500	3.5	6	.012	.094	76
WSM-87 E	.875	7/8	22.2	.600	18	.296	.583	3.5	7	.012	.094	66
WSM-87 F	.875	7/8	22.2	.600	18	.385	.750	3.5	9	.012	.094	50
WSM-87 G	.875	7/8	22.2	.600	18	.509	1.000	3.5	12	.012	.094	38
WSR-87 A	.875	7/8	22.2	.600	25	.166	.250	3.5	3	.015	.094	298
WSR-87 B	.875	7/8	22.2	.600	25	.214	.333	3.5	4	.015	.094	210
WSR-87 C	.875	7/8	22.2	.600	25	.278	.417	3.5	5	.015	.094	180
WSR-87 D	.875	7/8	22.2	.600	25	.327	.500	3.5	6	.015	.094	145
WSR-87 E	.875	7/8	22.2	.600	25	.395	.583	3.5	7	.015	.094	133
WSR-87 F	.875	7/8	22.2	.600	25	.510	.750	3.5	9	.015	.094	104
WSR-87 G	.875	7/8	22.2	.600	25	.670	1.000	3.5	12	.015	.094	78
WSL-100 A	1.000	1	25.4	.730	12	.084	.250	3.5	3	.010	.086	72
WSL-100 B	1.000	1	25.4	.730	12	.108	.333	3.5	4	.010	.086	53
WSL-100 C	1.000	1	25.4	.730	12	.145	.417	3.5	5	.010	.086	44
WSL-100 D	1.000	1	25.4	.730	12	.165	.500	3.5	6	.010	.086	36
WSL-100 E	1.000	1	25.4	.730	12	.201	.583	3.5	7	.010	.086	31
WSL-100 F	1.000	1	25.4	.730	12	.258	.750	3.5	9	.010	.086	24
WSL-100 G	1.000	1	25.4	.730	12	.342	1.000	3.5	12	.010	.086	18
WSL-100 H	1.000	1	25.4	.730	12	.445	1.250	3.5	15	.010	.086	15
WSL-100 I	1.000	1	25.4	.730	12	.519	1.500	3.5	18	.010	.086	12
WSL-100 J	1.000	1	25.4	.730	12	.633	1.750	3.5	21	.010	.086	11
WSL-100 K	1.000	1	25.4	.730	12	.710	2.000	3.5	24	.010	.086	9

PART NUMBERS SHOWN REFLECT MULTI-TURN WAVE SPRINGS WITH PLAIN ENDS.

THE LETTERS SHOWN AFTER THE PART NUMBERS REPRESENT THE NUMBER OF TURNS. WHEN ORDERING, PARTS SHOULD BE PRESENTED WITH THE PART NUMBER, FOLLOWED BY THE MATERIAL, AND THEN THE NUMBER OF TURNS (i.e. WSL-37ST A, WSM-50ST B, WSR-75ST C, ETC.)

FOR FLAT SHIM TOP WAVE SPRINGS, ADD AN 'F' TO THE END OF THE PART NUMBER (i.e. WSL-37ST AF, WSM-50ST BF, WSR-75ST CF, ETC.)

MATERIAL CODES: ST = CARBON STEEL. SQ = 17-7 PH/C STAINLESS STEEL. SPECIAL ALLOYS AVAILABLE UPON REQUEST.

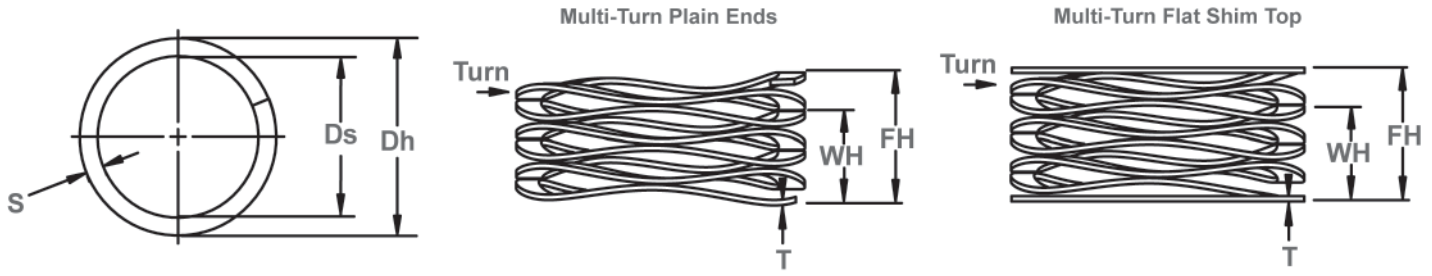

Wave Spring Measurements

WAVE SPRING NO.	PILOTS & OPERATES IN HOUSING DIAMETER			SHAFT DIAMETER CLEARANCE	LOAD (lbs.)	WORK HEIGHT	FREE HEIGHT Ref.	NUMBER OF WAVES	NUMBER OF TURNS	THICKNESS	SECTION	SPRING RATE Ref. Lb/in.
	Dh DEC	Dh FRAC	Dh mm			Ds	WH			FH	T	
WSM-100 A	1.000	1	25.4	.730	18	.087	.250	3.5	3	.012	.094	110
WSM-100 B	1.000	1	25.4	.730	18	.113	.333	3.5	4	.012	.094	82
WSM-100 C	1.000	1	25.4	.730	18	.148	.417	3.5	5	.012	.094	67
WSM-100 D	1.000	1	25.4	.730	18	.175	.500	3.5	6	.012	.094	55
WSM-100 E	1.000	1	25.4	.730	18	.212	.583	3.5	7	.012	.094	49
WSM-100 F	1.000	1	25.4	.730	18	.276	.750	3.5	9	.012	.094	38
WSM-100 G	1.000	1	25.4	.730	18	.360	1.000	3.5	12	.012	.094	28
WSM-100 H	1.000	1	25.4	.730	18	.452	1.250	3.5	15	.012	.094	23
WSM-100 I	1.000	1	25.4	.730	18	.549	1.500	3.5	18	.012	.094	19
WSM-100 J	1.000	1	25.4	.730	18	.650	1.750	3.5	21	.012	.094	16
WSM-100 K	1.000	1	25.4	.730	18	.720	2.000	3.5	24	.012	.094	14
WSR-100 A	1.000	1	25.4	.730	25	.131	.250	3.5	3	.015	.094	210
WSR-100 B	1.000	1	25.4	.730	25	.174	.333	3.5	4	.015	.094	157
WSR-100 C	1.000	1	25.4	.730	25	.227	.417	3.5	5	.015	.094	132
WSR-100 D	1.000	1	25.4	.730	25	.266	.500	3.5	6	.015	.094	107
WSR-100 E	1.000	1	25.4	.730	25	.319	.583	3.5	7	.015	.094	95
WSR-100 F	1.000	1	25.4	.730	25	.406	.750	3.5	9	.015	.094	73
WSR-100 G	1.000	1	25.4	.730	25	.541	1.000	3.5	12	.015	.094	54
WSR-100 H	1.000	1	25.4	.730	25	.688	1.250	3.5	15	.015	.094	45
WSR-100 I	1.000	1	25.4	.730	25	.813	1.500	3.5	18	.015	.094	36
WSR-100 J	1.000	1	25.4	.730	25	.957	1.750	3.5	21	.015	.094	32
WSR-100 K	1.000	1	25.4	.730	25	1.083	2.000	3.5	24	.015	.094	27
WSL-112 A	1.125	1-1/8	28.6	.850	12	.146	.300	3.5	3	.012	.094	78
WSL-112 B	1.125	1-1/8	28.6	.850	12	.186	.400	3.5	4	.012	.094	56
WSL-112 C	1.125	1-1/8	28.6	.850	12	.250	.500	3.5	5	.012	.094	48
WSL-112 D	1.125	1-1/8	28.6	.850	12	.295	.600	3.5	6	.012	.094	39
WSL-112 E	1.125	1-1/8	28.6	.850	12	.344	.700	3.5	7	.012	.094	34
WSL-112 F	1.125	1-1/8	28.6	.850	12	.392	.800	3.5	8	.012	.094	29
WSL-112 G	1.125	1-1/8	28.6	.850	12	.488	1.000	3.5	10	.012	.094	23
WSL-112 H	1.125	1-1/8	28.6	.850	12	.659	1.300	3.5	13	.012	.094	19
WSL-112 I	1.125	1-1/8	28.6	.850	12	.807	1.600	3.5	16	.012	.094	15
WSL-112 J	1.125	1-1/8	28.6	.850	12	1.017	2.000	3.5	20	.012	.094	12
WSM-112 A	1.125	1-1/8	28.6	.850	20	.160	.300	3.5	3	.015	.094	143
WSM-112 B	1.125	1-1/8	28.6	.850	20	.202	.400	3.5	4	.015	.094	101
WSM-112 C	1.125	1-1/8	28.6	.850	20	.270	.500	3.5	5	.015	.094	87
WSM-112 D	1.125	1-1/8	28.6	.850	20	.318	.600	3.5	6	.015	.094	71
WSM-112 E	1.125	1-1/8	28.6	.850	20	.381	.700	3.5	7	.015	.094	63
WSM-112 F	1.125	1-1/8	28.6	.850	20	.427	.800	3.5	8	.015	.094	54
WSM-112 G	1.125	1-1/8	28.6	.850	20	.536	1.000	3.5	10	.015	.094	43
WSM-112 H	1.125	1-1/8	28.6	.850	20	.708	1.300	3.5	13	.015	.094	34
WSM-112 I	1.125	1-1/8	28.6	.850	20	.861	1.600	3.5	16	.015	.094	27
WSM-112 J	1.125	1-1/8	28.6	.850	20	1.088	2.000	3.5	20	.015	.094	22

PART NUMBERS SHOWN REFLECT MULTI-TURN WAVE SPRINGS WITH PLAIN ENDS.

THE LETTERS SHOWN AFTER THE PART NUMBERS REPRESENT THE NUMBER OF TURNS. WHEN ORDERING, PARTS SHOULD BE PRESENTED WITH THE PART NUMBER, FOLLOWED BY THE MATERIAL, AND THEN THE NUMBER OF TURNS (i.e. WSL-37ST A, WSM-50ST B, WSR-75ST C, ETC.)

FOR FLAT SHIM TOP WAVE SPRINGS, ADD AN 'F' TO THE END OF THE PART NUMBER (i.e. WSL-37ST AF, WSM-50ST BF, WSR-75ST CF, ETC.)

MATERIAL CODES: ST = CARBON STEEL. SQ = 17-7 PH/C STAINLESS STEEL. SPECIAL ALLOYS AVAILABLE UPON REQUEST.

# WSL, WSM, WSR Wave Springs

## Multi Turn, Inch

Used for low to medium force applications with greater travel compared to single-turn springs. Utilizes nearly half the space as helical compression springs while producing the same force.

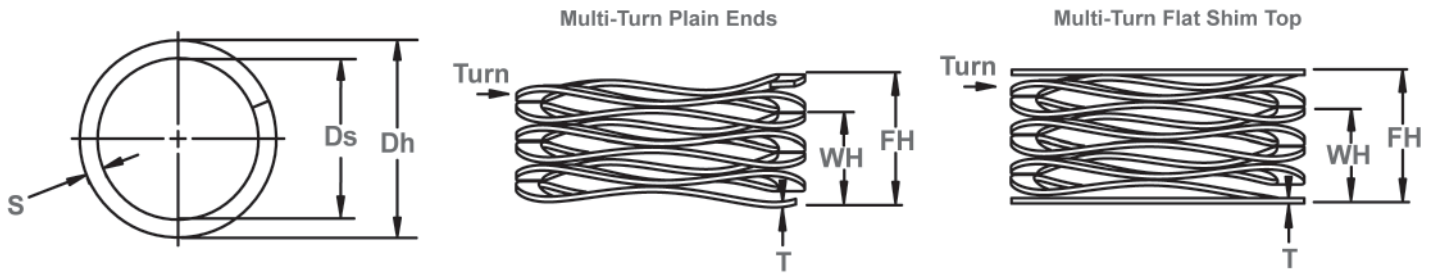

Wave Spring Measurements

WAVE SPRING NO.	PILOTS & OPERATES IN HOUSING DIAMETER			SHAFT DIAMETER CLEARANCE	LOAD (lbs.)	WORK HEIGHT	FREE HEIGHT Ref.	NUMBER OF WAVES	NUMBER OF TURNS	THICKNESS	SECTION	SPRING RATE Ref. Lb/in.
	Dh DEC	Dh FRAC	Dh mm			WH	FH			T	S	
				Ds								
WSR-112 A	1.125	1-1/8	28.6	.850	30	.178	.300	3.5	3	.018	.094	246
WSR-112 B	1.125	1-1/8	28.6	.850	30	.229	.400	3.5	4	.018	.094	175
WSR-112 C	1.125	1-1/8	28.6	.850	30	.303	.500	3.5	5	.018	.094	152
WSR-112 D	1.125	1-1/8	28.6	.850	30	.350	.600	3.5	6	.018	.094	120
WSR-112 E	1.125	1-1/8	28.6	.850	30	.421	.700	3.5	7	.018	.094	108
WSR-112 F	1.125	1-1/8	28.6	.850	30	.470	.800	3.5	8	.018	.094	91
WSR-112 G	1.125	1-1/8	28.6	.850	30	.593	1.000	3.5	10	.018	.094	74
WSR-112 H	1.125	1-1/8	28.6	.850	30	.787	1.300	3.5	13	.018	.094	58
WSR-112 I	1.125	1-1/8	28.6	.850	30	.956	1.600	3.5	16	.018	.094	47
WSR-112 J	1.125	1-1/8	28.6	.850	30	1.202	2.000	3.5	20	.018	.094	38
WSL-125 A	1.250	1-1/4	31.7	1.000	12	.084	.300	3.5	3	.012	.094	56
WSL-125 B	1.250	1-1/4	31.7	1.000	12	.113	.400	3.5	4	.012	.094	42
WSL-125 C	1.250	1-1/4	31.7	1.000	12	.149	.500	3.5	5	.012	.094	34
WSL-125 D	1.250	1-1/4	31.7	1.000	12	.172	.600	3.5	6	.012	.094	28
WSL-125 E	1.250	1-1/4	31.7	1.000	12	.207	.700	3.5	7	.012	.094	24
WSL-125 F	1.250	1-1/4	31.7	1.000	12	.227	.800	3.5	8	.012	.094	21
WSL-125 G	1.250	1-1/4	31.7	1.000	12	.301	1.000	3.5	10	.012	.094	17
WSL-125 H	1.250	1-1/4	31.7	1.000	12	.395	1.300	3.5	13	.012	.094	13
WSL-125 I	1.250	1-1/4	31.7	1.000	12	.467	1.600	3.5	16	.012	.094	11
WSL-125 J	1.250	1-1/4	31.7	1.000	12	.591	2.000	3.5	20	.012	.094	9
WSM-125 A	1.250	1-1/4	31.7	1.000	20	.124	.300	3.5	3	.015	.094	114
WSM-125 B	1.250	1-1/4	31.7	1.000	20	.165	.400	3.5	4	.015	.094	85
WSM-125 C	1.250	1-1/4	31.7	1.000	20	.215	.500	3.5	5	.015	.094	70
WSM-125 D	1.250	1-1/4	31.7	1.000	20	.253	.600	3.5	6	.015	.094	58
WSM-125 E	1.250	1-1/4	31.7	1.000	20	.303	.700	3.5	7	.015	.094	50
WSM-125 F	1.250	1-1/4	31.7	1.000	20	.341	.800	3.5	8	.015	.094	44
WSM-125 G	1.250	1-1/4	31.7	1.000	20	.427	1.000	3.5	10	.015	.094	35
WSM-125 H	1.250	1-1/4	31.7	1.000	20	.577	1.300	3.5	13	.015	.094	28
WSM-125 I	1.250	1-1/4	31.7	1.000	20	.692	1.600	3.5	16	.015	.094	22
WSM-125 J	1.250	1-1/4	31.7	1.000	20	.866	2.000	3.5	20	.015	.094	18
WSR-125 A	1.250	1-1/4	31.7	1.000	30	.158	.300	3.5	3	.019	.094	210
WSR-125 B	1.250	1-1/4	31.7	1.000	30	.210	.400	3.5	4	.019	.094	158
WSR-125 C	1.250	1-1/4	31.7	1.000	30	.272	.500	3.5	5	.019	.094	132
WSR-125 D	1.250	1-1/4	31.7	1.000	30	.320	.600	3.5	6	.019	.094	107
WSR-125 E	1.250	1-1/4	31.7	1.000	30	.384	.700	3.5	7	.019	.094	95
WSR-125 F	1.250	1-1/4	31.7	1.000	30	.433	.800	3.5	8	.019	.094	82
WSR-125 G	1.250	1-1/4	31.7	1.000	30	.538	1.000	3.5	10	.019	.094	65
WSR-125 H	1.250	1-1/4	31.7	1.000	30	.717	1.300	3.5	13	.019	.094	51
WSR-125 I	1.250	1-1/4	31.7	1.000	30	.878	1.600	3.5	16	.019	.094	42
WSR-125 J	1.250	1-1/4	31.7	1.000	30	1.103	2.000	3.5	20	.019	.094	33

PART NUMBERS SHOWN REFLECT MULTI-TURN WAVE SPRINGS WITH PLAIN ENDS.

THE LETTERS SHOWN AFTER THE PART NUMBERS REPRESENT THE NUMBER OF TURNS. WHEN ORDERING, PARTS SHOULD BE PRESENTED WITH THE PART NUMBER, FOLLOWED BY THE MATERIAL, AND THEN THE NUMBER OF TURNS (i.e. WSL-37ST A, WSM-50ST B, WSR-75ST C, ETC.)

FOR FLAT SHIM TOP WAVE SPRINGS, ADD AN 'F' TO THE END OF THE PART NUMBER (i.e. WSL-37ST AF, WSM-50ST BF, WSR-75ST CF, ETC.)

MATERIAL CODES: ST = CARBON STEEL. SQ = 17-7 PH/C STAINLESS STEEL. SPECIAL ALLOYS AVAILABLE UPON REQUEST.

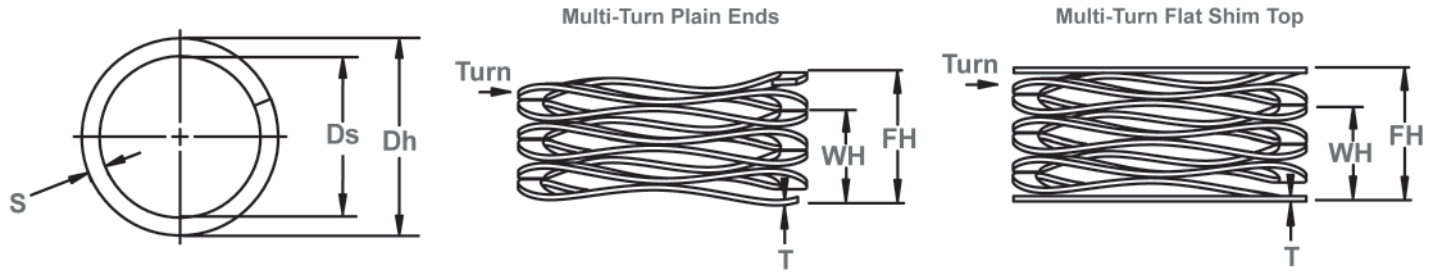

Wave Spring Measurements

WAVE SPRING NO.	PILOTS & OPERATES IN HOUSING DIAMETER			SHAFT DIAMETER CLEARANCE	LOAD (lbs.)	WORK HEIGHT	FREE HEIGHT Ref.	NUMBER OF WAVES	NUMBER OF TURNS	THICKNESS	SECTION	SPRING RATE Ref. Lb/in.
	Dh DEC	Dh FRAC	Dh mm			WH	FH			T	S	
	Ds											
WSL-137 A	1.375	1-3/8	34.9	1.030	15	.075	.300	3.5	3	.012	.122	67
WSL-137 B	1.375	1-3/8	34.9	1.030	15	.099	.400	3.5	4	.012	.122	50
WSL-137 C	1.375	1-3/8	34.9	1.030	15	.129	.500	3.5	5	.012	.122	40
WSL-137 D	1.375	1-3/8	34.9	1.030	15	.155	.600	3.5	6	.012	.122	34
WSL-137 E	1.375	1-3/8	34.9	1.030	15	.179	.700	3.5	7	.012	.122	29
WSL-137 F	1.375	1-3/8	34.9	1.030	15	.206	.800	3.5	8	.012	.122	25
WSL-137 G	1.375	1-3/8	34.9	1.030	15	.256	1.000	3.5	10	.012	.122	20
WSL-137 H	1.375	1-3/8	34.9	1.030	15	.341	1.300	3.5	13	.012	.122	16
WSL-137 I	1.375	1-3/8	34.9	1.030	15	.424	1.600	3.5	16	.012	.122	13
WSL-137 J	1.375	1-3/8	34.9	1.030	15	.530	2.000	3.5	20	.012	.122	10
WSM-137 A	1.375	1-3/8	34.9	1.030	25	.142	.300	3.5	3	.016	.133	158
WSM-137 B	1.375	1-3/8	34.9	1.030	25	.186	.400	3.5	4	.016	.133	117
WSM-137 C	1.375	1-3/8	34.9	1.030	25	.240	.500	3.5	5	.016	.133	96
WSM-137 D	1.375	1-3/8	34.9	1.030	25	.281	.600	3.5	6	.016	.133	78
WSM-137 E	1.375	1-3/8	34.9	1.030	25	.340	.700	3.5	7	.016	.133	69
WSM-137 F	1.375	1-3/8	34.9	1.030	25	.384	.800	3.5	8	.016	.133	60
WSM-137 G	1.375	1-3/8	34.9	1.030	25	.486	1.000	3.5	10	.016	.133	49
WSM-137 H	1.375	1-3/8	34.9	1.030	25	.632	1.300	3.5	13	.016	.133	37
WSM-137 I	1.375	1-3/8	34.9	1.030	25	.788	1.600	3.5	16	.016	.133	31
WSM-137 J	1.375	1-3/8	34.9	1.030	25	.982	2.000	3.5	20	.016	.133	25
WSR-137 A	1.375	1-3/8	34.9	1.030	35	.149	.300	3.5	3	.018	.133	232
WSR-137 B	1.375	1-3/8	34.9	1.030	35	.189	.400	3.5	4	.018	.133	166
WSR-137 C	1.375	1-3/8	34.9	1.030	35	.247	.500	3.5	5	.018	.133	138
WSR-137 D	1.375	1-3/8	34.9	1.030	35	.287	.600	3.5	6	.018	.133	112
WSR-137 E	1.375	1-3/8	34.9	1.030	35	.343	.700	3.5	7	.018	.133	98
WSR-137 F	1.375	1-3/8	34.9	1.030	35	.390	.800	3.5	8	.018	.133	85
WSR-137 G	1.375	1-3/8	34.9	1.030	35	.490	1.000	3.5	10	.018	.133	69
WSR-137 H	1.375	1-3/8	34.9	1.030	35	.646	1.300	3.5	13	.018	.133	54
WSR-137 I	1.375	1-3/8	34.9	1.030	35	.793	1.600	3.5	16	.018	.133	43
WSR-137 J	1.375	1-3/8	34.9	1.030	35	1.000	2.000	3.5	20	.018	.133	35
WSL-150 A	1.500	1-1/2	38.1	1.140	20	.129	.300	3.5	3	.016	.133	117
WSL-150 B	1.500	1-1/2	38.1	1.140	20	.164	.400	3.5	4	.016	.133	85
WSL-150 C	1.500	1-1/2	38.1	1.140	20	.213	.500	3.5	5	.016	.133	70
WSL-150 D	1.500	1-1/2	38.1	1.140	20	.247	.600	3.5	6	.016	.133	57
WSL-150 E	1.500	1-1/2	38.1	1.140	20	.301	.700	3.5	7	.016	.133	50
WSL-150 F	1.500	1-1/2	38.1	1.140	20	.337	.800	3.5	8	.016	.133	43
WSL-150 G	1.500	1-1/2	38.1	1.140	20	.430	1.000	3.5	10	.016	.133	35
WSL-150 H	1.500	1-1/2	38.1	1.140	20	.565	1.300	3.5	13	.016	.133	27
WSL-150 I	1.500	1-1/2	38.1	1.140	20	.694	1.600	3.5	16	.016	.133	22
WSL-150 J	1.500	1-1/2	38.1	1.140	20	.866	2.000	3.5	20	.016	.133	18

PART NUMBERS SHOWN REFLECT MULTI-TURN WAVE SPRINGS WITH PLAIN ENDS.

THE LETTERS SHOWN AFTER THE PART NUMBERS REPRESENT THE NUMBER OF TURNS. WHEN ORDERING, PARTS SHOULD BE PRESENTED WITH THE PART NUMBER, FOLLOWED BY THE MATERIAL, AND THEN THE NUMBER OF TURNS (i.e. WSL-37ST A, WSM-50ST B, WSR-75ST C, ETC.)

FOR FLAT SHIM TOP WAVE SPRINGS, ADD AN 'F' TO THE END OF THE PART NUMBER (i.e. WSL-37ST AF, WSM-50ST BF, WSR-75ST CF, ETC.)

MATERIAL CODES: ST = CARBON STEEL. SQ = 17-7 PH/C STAINLESS STEEL. SPECIAL ALLOYS AVAILABLE UPON REQUEST.

# WSL, WSM, WSR Wave Springs

## Multi Turn, Inch

Used for low to medium force applications with greater travel compared to single-turn springs. Utilizes nearly half the space as helical compression springs while producing the same force.

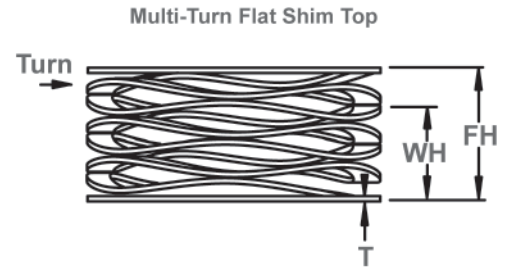
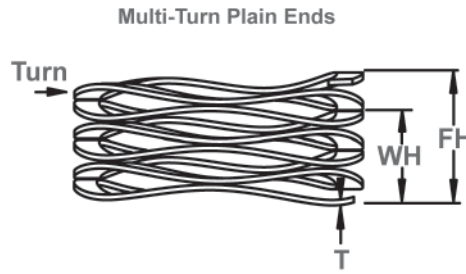
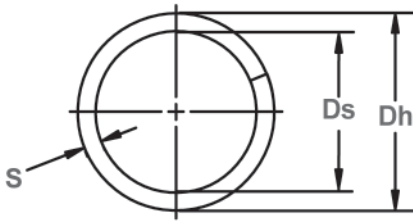

Wave Spring Measurements

WAVE SPRING NO.	PILOTS & OPERATES IN HOUSING DIAMETER			SHAFT DIAMETER CLEARANCE	LOAD (lbs.)	WORK HEIGHT	FREE HEIGHT Ref.	NUMBER OF WAVES	NUMBER OF TURNS	THICKNESS	SECTION	SPRING RATE Ref. Lb/in.
	Dh DEC	Dh FRAC	Dh mm									
	Ds											
WSM-150 A	1.500	1-1/2	38.1	1.140	35	.122	.300	3.5	3	.018	.133	197
WSM-150 B	1.500	1-1/2	38.1	1.140	35	.158	.400	3.5	4	.018	.133	145
WSM-150 C	1.500	1-1/2	38.1	1.140	35	.206	.500	3.5	5	.018	.133	119
WSM-150 D	1.500	1-1/2	38.1	1.140	35	.241	.600	3.5	6	.018	.133	97
WSM-150 E	1.500	1-1/2	38.1	1.140	35	.291	.700	3.5	7	.018	.133	86
WSM-150 F	1.500	1-1/2	38.1	1.140	35	.324	.800	3.5	8	.018	.133	74
WSM-150 G	1.500	1-1/2	38.1	1.140	35	.409	1.000	3.5	10	.018	.133	59
WSM-150 H	1.500	1-1/2	38.1	1.140	35	.540	1.300	3.5	13	.018	.133	46
WSM-150 I	1.500	1-1/2	38.1	1.140	35	.657	1.600	3.5	16	.018	.133	37
WSM-150 J	1.500	1-1/2	38.1	1.140	35	.835	2.000	3.5	20	.018	.133	30
WSR-150 A	1.500	1-1/2	38.1	1.140	60	.166	.300	4.5	3	.018	.133	448
WSR-150 B	1.500	1-1/2	38.1	1.140	60	.216	.400	4.5	4	.018	.133	326
WSR-150 C	1.500	1-1/2	38.1	1.140	60	.278	.500	4.5	5	.018	.133	270
WSR-150 D	1.500	1-1/2	38.1	1.140	60	.329	.600	4.5	6	.018	.133	221
WSR-150 E	1.500	1-1/2	38.1	1.140	60	.390	.700	4.5	7	.018	.133	194
WSR-150 F	1.500	1-1/2	38.1	1.140	60	.443	.800	4.5	8	.018	.133	168
WSR-150 G	1.500	1-1/2	38.1	1.140	60	.555	1.000	4.5	10	.018	.133	135
WSR-150 H	1.500	1-1/2	38.1	1.140	60	.726	1.300	4.5	13	.018	.133	105
WSR-150 I	1.500	1-1/2	38.1	1.140	60	.890	1.600	4.5	16	.018	.133	85
WSR-150 J	1.500	1-1/2	38.1	1.140	60	1.119	2.000	4.5	20	.018	.133	68
WSL-175 A	1.750	1-3/4	44.4	1.340	25	.155	.375	3.5	3	.018	.143	114
WSL-175 B	1.750	1-3/4	44.4	1.340	25	.200	.500	3.5	4	.018	.143	83
WSL-175 C	1.750	1-3/4	44.4	1.340	25	.265	.625	3.5	5	.018	.143	69
WSL-175 D	1.750	1-3/4	44.4	1.340	25	.310	.750	3.5	6	.018	.143	57
WSL-175 E	1.750	1-3/4	44.4	1.340	25	.367	.870	3.5	7	.018	.143	50
WSL-175 F	1.750	1-3/4	44.4	1.340	25	.415	1.000	3.5	8	.018	.143	43
WSL-175 G	1.750	1-3/4	44.4	1.340	25	.523	1.250	3.5	10	.018	.143	34
WSL-175 H	1.750	1-3/4	44.4	1.340	25	.638	1.500	3.5	12	.018	.143	29
WSL-175 I	1.750	1-3/4	44.4	1.340	25	.737	1.750	3.5	14	.018	.143	25
WSL-175 J	1.750	1-3/4	44.4	1.340	25	.844	2.000	3.5	16	.018	.143	22
WSM-175 A	1.750	1-3/4	44.4	1.340	50	.188	.375	4.5	3	.018	.143	267
WSM-175 B	1.750	1-3/4	44.4	1.340	50	.244	.500	4.5	4	.018	.143	195
WSM-175 C	1.750	1-3/4	44.4	1.340	50	.315	.625	4.5	5	.018	.143	161
WSM-175 D	1.750	1-3/4	44.4	1.340	50	.374	.750	4.5	6	.018	.143	133
WSM-175 E	1.750	1-3/4	44.4	1.340	50	.452	.870	4.5	7	.018	.143	120
WSM-175 F	1.750	1-3/4	44.4	1.340	50	.505	1.000	4.5	8	.018	.143	101
WSM-175 G	1.750	1-3/4	44.4	1.340	50	.629	1.250	4.5	10	.018	.143	81
WSM-175 H	1.750	1-3/4	44.4	1.340	50	.768	1.500	4.5	12	.018	.143	68
WSM-175 I	1.750	1-3/4	44.4	1.340	50	.899	1.750	4.5	14	.018	.143	59
WSM-175 J	1.750	1-3/4	44.4	1.340	50	1.026	2.000	4.5	16	.018	.143	51

PART NUMBERS SHOWN REFLECT MULTI-TURN WAVE SPRINGS WITH PLAIN ENDS.

THE LETTERS SHOWN AFTER THE PART NUMBERS REPRESENT THE NUMBER OF TURNS. WHEN ORDERING, PARTS SHOULD BE PRESENTED WITH THE PART NUMBER, FOLLOWED BY THE MATERIAL, AND THEN THE NUMBER OF TURNS (i.e. WSL-37ST A, WSM-50ST B, WSR-75ST C, ETC.)

FOR FLAT SHIM TOP WAVE SPRINGS, ADD AN 'F' TO THE END OF THE PART NUMBER (i.e. WSL-37ST AF, WSM-50ST BF, WSR-75ST CF, ETC.)

MATERIAL CODES: ST = CARBON STEEL. SQ = 17-7 PH/C STAINLESS STEEL. SPECIAL ALLOYS AVAILABLE UPON REQUEST.



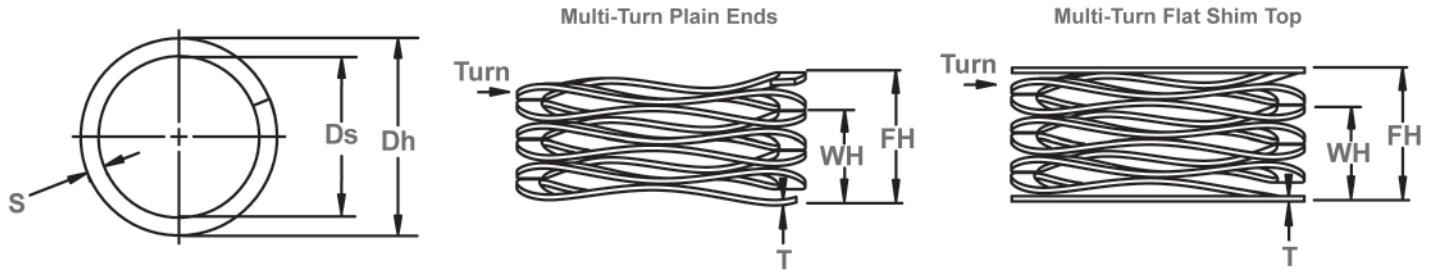

Wave Spring Measurements

WAVE SPRING NO.	PILOTS & OPERATES IN HOUSING DIAMETER			SHAFT DIAMETER CLEARANCE	LOAD (lbs.)	WORK HEIGHT	FREE HEIGHT Ref.	NUMBER OF WAVES	NUMBER OF TURNS	THICKNESS	SECTION	SPRING RATE Ref. Lb/in.
	Dh DEC	Dh FRAC	Dh mm									
						Ds	WH			FH	T	
WSR-175 A	1.750	1-3/4	44.4	1.340	90	.232	.375	4.5	3	.024	.148	629
WSR-175 B	1.750	1-3/4	44.4	1.340	90	.314	.500	4.5	4	.024	.148	484
WSR-175 C	1.750	1-3/4	44.4	1.340	90	.409	.625	4.5	5	.024	.148	417
WSR-175 D	1.750	1-3/4	44.4	1.340	90	.482	.750	4.5	6	.024	.148	336
WSR-175 E	1.750	1-3/4	44.4	1.340	90	.577	.870	4.5	7	.024	.148	307
WSR-175 F	1.750	1-3/4	44.4	1.340	90	.651	1.000	4.5	8	.024	.148	258
WSR-175 G	1.750	1-3/4	44.4	1.340	90	.813	1.250	4.5	10	.024	.148	206
WSR-175 H	1.750	1-3/4	44.4	1.340	90	.980	1.500	4.5	12	.024	.148	173
WSR-175 I	1.750	1-3/4	44.4	1.340	90	1.147	1.750	4.5	14	.024	.148	149
WSR-175 J	1.750	1-3/4	44.4	1.340	90	1.317	2.000	4.5	16	.024	.148	132
WSL-200 A	2.000	2	50.8	1.600	25	.094	.375	3.5	3	.018	.143	89
WSL-200 B	2.000	2	50.8	1.600	25	.120	.500	3.5	4	.018	.143	66
WSL-200 C	2.000	2	50.8	1.600	25	.158	.625	3.5	5	.018	.143	54
WSL-200 D	2.000	2	50.8	1.600	25	.179	.750	3.5	6	.018	.143	44
WSL-200 E	2.000	2	50.8	1.600	25	.217	.870	3.5	7	.018	.143	38
WSL-200 F	2.000	2	50.8	1.600	25	.243	1.000	3.5	8	.018	.143	33
WSL-200 G	2.000	2	50.8	1.600	25	.306	1.250	3.5	10	.018	.143	26
WSL-200 H	2.000	2	50.8	1.600	25	.365	1.500	3.5	12	.018	.143	22
WSL-200 I	2.000	2	50.8	1.600	25	.433	1.750	3.5	14	.018	.143	19
WSL-200 J	2.000	2	50.8	1.600	25	.490	2.000	3.5	16	.018	.143	17
WSM-200 A	2.000	2	50.8	1.600	50	.140	.375	4.5	3	.018	.143	213
WSM-200 B	2.000	2	50.8	1.600	50	.184	.500	4.5	4	.018	.143	158
WSM-200 C	2.000	2	50.8	1.600	50	.245	.625	4.5	5	.018	.143	132
WSM-200 D	2.000	2	50.8	1.600	50	.278	.750	4.5	6	.018	.143	106
WSM-200 E	2.000	2	50.8	1.600	50	.345	.870	4.5	7	.018	.143	95
WSM-200 F	2.000	2	50.8	1.600	50	.395	1.000	4.5	8	.018	.143	83
WSM-200 G	2.000	2	50.8	1.600	50	.498	1.250	4.5	10	.018	.143	66
WSM-200 H	2.000	2	50.8	1.600	50	.593	1.500	4.5	12	.018	.143	55
WSM-200 I	2.000	2	50.8	1.600	50	.694	1.750	4.5	14	.018	.143	47
WSM-200 J	2.000	2	50.8	1.600	50	.800	2.000	4.5	16	.018	.143	42
WSR-200 A	2.000	2	50.8	1.600	90	.197	.375	4.5	3	.024	.148	506
WSR-200 B	2.000	2	50.8	1.600	90	.258	.500	4.5	4	.024	.148	372
WSR-200 C	2.000	2	50.8	1.600	90	.332	.625	4.5	5	.024	.148	307
WSR-200 D	2.000	2	50.8	1.600	90	.389	.750	4.5	6	.024	.148	249
WSR-200 E	2.000	2	50.8	1.600	90	.465	.870	4.5	7	.024	.148	222
WSR-200 F	2.000	2	50.8	1.600	90	.525	1.000	4.5	8	.024	.148	189
WSR-200 G	2.000	2	50.8	1.600	90	.661	1.250	4.5	10	.024	.148	153
WSR-200 H	2.000	2	50.8	1.600	90	.781	1.500	4.5	12	.024	.148	125
WSR-200 I	2.000	2	50.8	1.600	90	.941	1.750	4.5	14	.024	.148	111
WSR-200 J	2.000	2	50.8	1.600	90	1.069	2.000	4.5	16	.024	.148	97

PART NUMBERS SHOWN REFLECT MULTI-TURN WAVE SPRINGS WITH PLAIN ENDS.  
 THE LETTERS SHOWN AFTER THE PART NUMBERS REPRESENT THE NUMBER OF TURNS. WHEN ORDERING, PARTS SHOULD BE PRESENTED WITH THE PART NUMBER, FOLLOWED BY THE MATERIAL, AND THEN THE NUMBER OF TURNS (i.e. WSL-37ST A, WSM-50ST B, WSR-75ST C, ETC.)  
 FOR FLAT SHIM TOP WAVE SPRINGS, ADD AN 'F' TO THE END OF THE PART NUMBER (i.e. WSL-37ST AF, WSM-50ST BF, WSR-75ST CF, ETC.)

MATERIAL CODES: ST = CARBON STEEL. SQ = 17-7 PH/C STAINLESS STEEL. SPECIAL ALLOYS AVAILABLE UPON REQUEST.

# MWL, MWM, MWR Wave Springs

## Multi Turn, Metric

Used for low to medium force applications with greater travel compared to single-turn springs. Utilizes nearly half the space as helical compression springs while producing the same force.

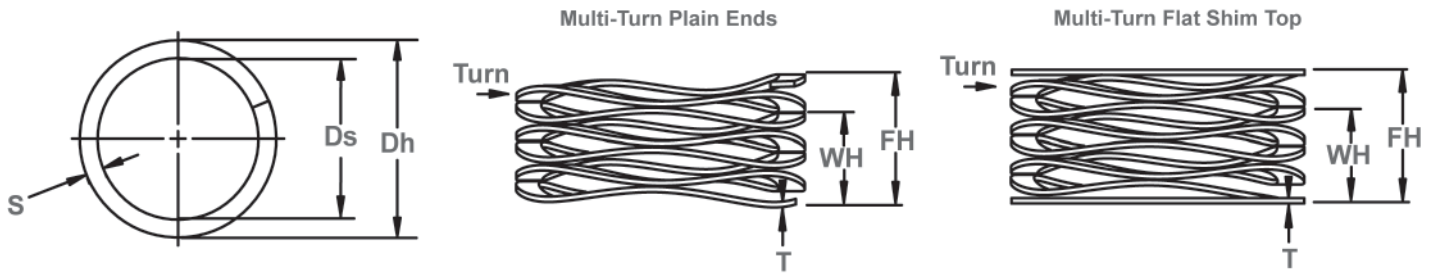

Wave Spring Measurements

WAVE SPRING NO.	PILOTS & OPERATES IN HOUSING DIAMETER		SHAFT DIAMETER CLEARANCE	LOAD (N)	WORK HEIGHT	FREE HEIGHT Ref.	NUMBER OF WAVES	NUMBER OF TURNS	THICKNESS	SECTION	SPRING RATE Ref. N/mm
	Dh mm	Ds									
MWL-6 A*	6	4	6	0.61	1.52	2.5	3	0.13	0.51	6.56	
MWL-6 B*	6	4	6	0.81	2.03	2.5	4	0.13	0.51	4.92	
MWL-6 C*	6	4	6	1.02	2.54	2.5	5	0.13	0.51	3.94	
MWL-6 D*	6	4	6	1.22	3.05	2.5	6	0.13	0.51	3.28	
MWL-6 E*	6	4	6	1.42	3.56	2.5	7	0.13	0.51	2.81	
MWL-6 F*	6	4	6	1.63	4.06	2.5	8	0.13	0.51	2.46	
MWL-6 G*	6	4	6	1.83	4.57	2.5	9	0.13	0.51	2.19	
MWL-6 H*	6	4	6	2.24	5.59	2.5	11	0.13	0.51	1.79	
MWL-6 I*	6	4	6	2.64	6.60	2.5	13	0.13	0.51	1.51	
MWM-6 A*	6	4	12	0.74	1.52	2.5	3	0.15	0.61	15.24	
MWM-6 B*	6	4	12	0.97	2.03	2.5	4	0.15	0.61	11.25	
MWM-6 C*	6	4	12	1.22	2.54	2.5	5	0.15	0.61	9.09	
MWM-6 D*	6	4	12	1.47	3.05	2.5	6	0.15	0.61	7.62	
MWM-6 E*	6	4	12	1.70	3.56	2.5	7	0.15	0.61	6.47	
MWM-6 F*	6	4	12	1.96	4.06	2.5	8	0.15	0.61	5.69	
MWM-6 G*	6	4	12	2.18	4.57	2.5	9	0.15	0.61	5.03	
MWM-6 H*	6	4	12	2.69	5.59	2.5	11	0.15	0.61	4.14	
MWM-6 I*	6	4	12	3.18	6.60	2.5	13	0.15	0.61	3.50	
MWL-8 A	8	5	15	1.70	2.82	2.5	3	0.20	0.81	13.42	
MWL-8 B	8	5	15	2.39	3.76	2.5	4	0.20	0.81	10.94	
MWL-8 C	8	5	15	2.74	4.70	2.5	5	0.20	0.81	7.67	
MWL-8 D	8	5	15	3.56	5.64	2.5	6	0.20	0.81	7.20	
MWL-8 E	8	5	15	4.01	6.58	2.5	7	0.20	0.81	5.85	
MWL-8 F	8	5	15	4.57	7.52	2.5	8	0.20	0.81	5.09	
MWL-8 G	8	5	15	5.26	8.46	2.5	9	0.20	0.81	4.69	
MWL-8 H	8	5	15	6.35	10.34	2.5	11	0.20	0.81	3.76	
MWL-8 I	8	5	15	7.37	12.22	2.5	13	0.20	0.81	3.09	
MWM-8 A	8	5	30	1.78	2.82	2.5	3	0.25	0.81	28.81	
MWM-8 B	8	5	30	2.54	3.76	2.5	4	0.25	0.81	24.61	
MWM-8 C	8	5	30	3.05	4.70	2.5	5	0.25	0.81	18.17	
MWM-8 D	8	5	30	3.81	5.64	2.5	6	0.25	0.81	16.40	
MWM-8 E	8	5	30	4.32	6.58	2.5	7	0.25	0.81	13.27	
MWM-8 F	8	5	30	4.95	7.52	2.5	8	0.25	0.81	11.69	
MWM-8 G	8	5	30	5.59	8.46	2.5	9	0.25	0.81	10.45	
MWM-8 H	8	5	30	6.86	10.34	2.5	11	0.25	0.81	8.62	
MWM-8 I	8	5	30	7.87	12.22	2.5	13	0.25	0.81	6.91	

\*Not available with shim ends

ALL DIMENSIONS IN MILLIMETERS UNLESS OTHERWISE SPECIFIED.

PART NUMBERS SHOWN REFLECT MULTI-TURN WAVE SPRINGS WITH PLAIN ENDS.

THE LETTERS SHOWN AFTER THE PART NUMBERS REPRESENT THE NUMBER OF TURNS. WHEN ORDERING, PARTS SHOULD BE PRESENTED WITH THE PART NUMBER, FOLLOWED BY THE MATERIAL, AND THEN THE NUMBER OF TURNS (i.e. MWL-8ST A, MWM-10ST B, MWR-14ST C, ETC.)

FOR FLAT SHIM TOP WAVE SPRINGS, ADD AN 'F' TO THE END OF THE PART NUMBER (i.e. MWL-8ST AF, MWM-10ST BF, MWR-14ST CF, ETC.)

MATERIAL CODES: ST = CARBON STEEL. SQ = 17-7 PH/C STAINLESS STEEL. SPECIAL ALLOYS AVAILABLE UPON REQUEST.

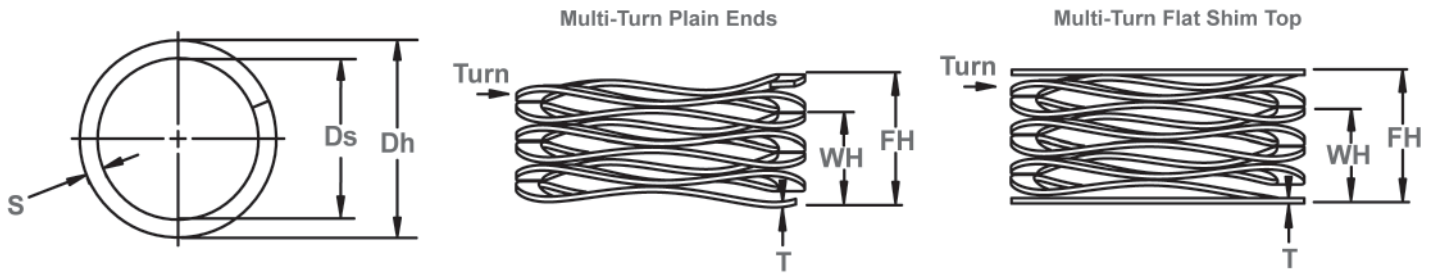

Wave Spring Measurements

WAVE SPRING NO.	PILOTS & OPERATES IN HOUSING DIAMETER		SHAFT DIAMETER CLEARANCE	LOAD (N)	WORK HEIGHT		FREE HEIGHT Ref.	NUMBER OF WAVES	NUMBER OF TURNS	THICKNESS	SECTION		SPRING RATE Ref. N/mm
	Dh mm	Ds			WH	FH					T	S	
MWL-10 A	10	7	18	1.91	3.96	2.5	3	0.20	0.81	8.75			
MWL-10 B	10	7	18	2.54	5.28	2.5	4	0.20	0.81	6.56			
MWL-10 C	10	7	18	3.15	6.60	2.5	5	0.20	0.81	5.21			
MWL-10 D	10	7	18	3.78	7.92	2.5	6	0.20	0.81	4.35			
MWL-10 E	10	7	18	4.42	9.25	2.5	7	0.20	0.81	3.73			
MWL-10 F	10	7	18	5.05	10.57	2.5	8	0.20	0.81	3.27			
MWL-10 G	10	7	18	5.69	11.89	2.5	9	0.20	0.81	2.90			
MWL-10 H	10	7	18	6.32	13.21	2.5	10	0.20	0.81	2.61			
MWL-10 I	10	7	18	6.96	14.53	2.5	11	0.20	0.81	2.38			
MWM-10 A	10	7	35	2.03	3.96	2.5	3	0.28	0.81	18.13			
MWM-10 B	10	7	35	2.79	5.28	2.5	4	0.28	0.81	14.06			
MWM-10 C	10	7	35	3.56	6.60	2.5	5	0.28	0.81	11.48			
MWM-10 D	10	7	35	4.32	7.92	2.5	6	0.28	0.81	9.70			
MWM-10 E	10	7	35	5.08	9.25	2.5	7	0.28	0.81	8.40			
MWM-10 F	10	7	35	5.84	10.57	2.5	8	0.28	0.81	7.41			
MWM-10 G	10	7	35	6.60	11.89	2.5	9	0.28	0.81	6.62			
MWM-10 H	10	7	35	7.37	13.21	2.5	10	0.28	0.81	5.99			
MWM-10 I	10	7	35	8.13	14.53	2.5	11	0.28	0.81	5.47			
MWL-12 A	12	9	20	1.47	4.34	2.5	3	0.20	1.02	6.97			
MWL-12 B	12	9	20	1.98	5.79	2.5	4	0.20	1.02	5.25			
MWL-12 C	12	9	20	2.46	7.24	2.5	5	0.20	1.02	4.19			
MWL-12 D	12	9	20	2.95	8.69	2.5	6	0.20	1.02	3.48			
MWL-12 E	12	9	20	3.45	10.13	2.5	7	0.20	1.02	2.99			
MWL-12 F	12	9	20	3.94	11.58	2.5	8	0.20	1.02	2.62			
MWL-12 G	12	9	20	4.45	13.03	2.5	9	0.20	1.02	2.33			
MWL-12 H	12	9	20	4.93	14.48	2.5	10	0.20	1.02	2.09			
MWL-12 I	12	9	20	5.44	15.93	2.5	11	0.20	1.02	1.91			
MWM-12 A	12	8.5	40	2.36	4.34	2.5	3	0.28	1.17	20.19			
MWM-12 B	12	8.5	40	3.18	5.79	2.5	4	0.28	1.17	15.29			
MWM-12 C	12	8.5	40	3.96	7.24	2.5	5	0.28	1.17	12.21			
MWM-12 D	12	8.5	40	4.75	8.69	2.5	6	0.28	1.17	10.16			
MWM-12 E	12	8.5	40	5.54	10.13	2.5	7	0.28	1.17	8.70			
MWM-12 F	12	8.5	40	6.32	11.58	2.5	8	0.28	1.17	7.61			
MWM-12 G	12	8.5	40	7.11	13.03	2.5	9	0.28	1.17	6.76			
MWM-12 H	12	8.5	40	7.92	14.48	2.5	10	0.28	1.17	6.10			
MWM-12 I	12	8.5	40	8.71	15.93	2.5	11	0.28	1.17	5.55			

ALL DIMENSIONS IN MILLIMETERS UNLESS OTHERWISE SPECIFIED.

PART NUMBERS SHOWN REFLECT MULTI-TURN WAVE SPRINGS WITH PLAIN ENDS.

THE LETTERS SHOWN AFTER THE PART NUMBERS REPRESENT THE NUMBER OF TURNS. WHEN ORDERING, PARTS SHOULD BE PRESENTED WITH THE PART NUMBER, FOLLOWED BY THE MATERIAL, AND THEN THE NUMBER OF TURNS (i.e. MWL-8ST A, MWM-10ST B, MWR-14ST C, ETC.)

FOR FLAT SHIM TOP WAVE SPRINGS, ADD AN 'F' TO THE END OF THE PART NUMBER (i.e. MWL-8ST AF, MWM-10ST BF, MWR-14ST CF, ETC.)

MATERIAL CODES: ST = CARBON STEEL. SQ = 17-7 PH/C STAINLESS STEEL. SPECIAL ALLOYS AVAILABLE UPON REQUEST.

# MWL, MWM, MWR Wave Springs

## Multi Turn, Metric

Used for low to medium force applications with greater travel compared to single-turn springs. Utilizes nearly half the space as helical compression springs while producing the same force.

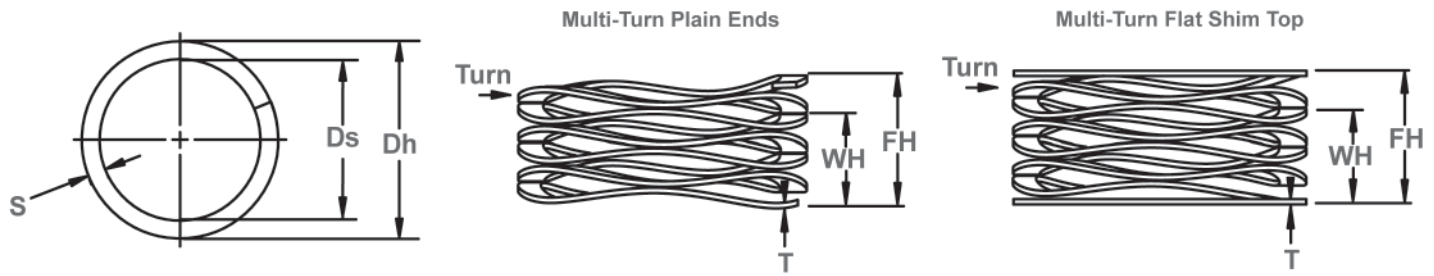

Wave Spring Measurements

WAVE SPRING NO.	PILOTS & OPERATES IN HOUSING DIAMETER		SHAFT DIAMETER CLEARANCE	LOAD (N)	WORK HEIGHT	FREE HEIGHT Ref.	NUMBER OF WAVES	NUMBER OF TURNS	THICKNESS	SECTION	SPRING RATE Ref. N/mm
	Dh mm	Ds							T	S	
MWR-12 A	12	8.5	60	1.98	4.34	2.5	3	0.30	1.14	25.40	
MWR-12 B	12	8.5	60	2.64	5.79	2.5	4	0.30	1.14	19.05	
MWR-12 C	12	8.5	60	3.30	7.24	2.5	5	0.30	1.14	15.24	
MWR-12 D	12	8.5	60	3.99	8.69	2.5	6	0.30	1.14	12.77	
MWR-12 E	12	8.5	60	4.65	10.13	2.5	7	0.30	1.14	10.94	
MWR-12 F	12	8.5	60	5.31	11.58	2.5	8	0.30	1.14	9.56	
MWR-12 G	12	8.5	60	5.97	13.03	2.5	9	0.30	1.14	8.50	
MWR-12 H	12	8.5	60	6.63	14.48	2.5	10	0.30	1.14	7.64	
MWR-12 I	12	8.5	60	7.29	15.93	2.5	11	0.30	1.14	6.95	
MWL-14 A	14	10	22	2.18	4.95	2.5	3	0.23	1.47	7.95	
MWL-14 B	14	10	22	2.95	6.60	2.5	4	0.23	1.47	6.01	
MWL-14 C	14	10	22	3.71	8.26	2.5	5	0.23	1.47	4.84	
MWL-14 D	14	10	22	4.52	9.91	2.5	6	0.23	1.47	4.09	
MWL-14 E	14	10	22	5.33	11.56	2.5	7	0.23	1.47	3.54	
MWL-14 F	14	10	22	6.17	13.21	2.5	8	0.23	1.47	3.13	
MWL-14 G	14	10	22	7.01	14.86	2.5	9	0.23	1.47	2.80	
MWL-14 H	14	10	22	7.85	16.51	2.5	10	0.23	1.47	2.54	
MWL-14 I	14	10	22	8.71	18.16	2.5	11	0.23	1.47	2.33	
MWM-14 A	14	10	50	2.18	4.95	2.5	3	0.30	1.52	18.06	
MWM-14 B	14	10	50	2.95	6.60	2.5	4	0.30	1.52	13.67	
MWM-14 C	14	10	50	3.71	8.26	2.5	5	0.30	1.52	11.00	
MWM-14 D	14	10	50	4.52	9.91	2.5	6	0.30	1.52	9.29	
MWM-14 E	14	10	50	5.33	11.56	2.5	7	0.30	1.52	8.03	
MWM-14 F	14	10	50	6.17	13.21	2.5	8	0.30	1.52	7.11	
MWM-14 G	14	10	50	7.01	14.86	2.5	9	0.30	1.52	6.37	
MWM-14 H	14	10	50	7.85	16.51	2.5	10	0.30	1.52	5.77	
MWM-14 I	14	10	50	8.71	18.16	2.5	11	0.30	1.52	5.29	
MWR-14 A	14	9	80	3.15	4.95	2.5	3	0.38	1.52	44.36	
MWR-14 B	14	9	80	4.19	6.60	2.5	4	0.38	1.52	33.15	
MWR-14 C	14	9	80	5.26	8.26	2.5	5	0.38	1.52	26.69	
MWR-14 D	14	9	80	6.30	9.91	2.5	6	0.38	1.52	22.18	
MWR-14 E	14	9	80	7.34	11.56	2.5	7	0.38	1.52	18.97	
MWR-14 F	14	9	80	8.41	13.21	2.5	8	0.38	1.52	16.66	
MWR-14 G	14	9	80	9.45	14.86	2.5	9	0.38	1.52	14.79	
MWR-14 H	14	9	80	10.49	16.51	2.5	10	0.38	1.52	13.29	
MWR-14 I	14	9	80	11.56	18.16	2.5	11	0.38	1.52	12.11	

ALL DIMENSIONS IN MILLIMETERS UNLESS OTHERWISE SPECIFIED.

PART NUMBERS SHOWN REFLECT MULTI-TURN WAVE SPRINGS WITH PLAIN ENDS.

THE LETTERS SHOWN AFTER THE PART NUMBERS REPRESENT THE NUMBER OF TURNS. WHEN ORDERING, PARTS SHOULD BE PRESENTED WITH THE PART NUMBER, FOLLOWED BY THE MATERIAL, AND THEN THE NUMBER OF TURNS (i.e. MWL-8ST A, MWM-10ST B, MWR-14ST C, ETC.)

FOR FLAT SHIM TOP WAVE SPRINGS, ADD AN 'F' TO THE END OF THE PART NUMBER (i.e. MWL-8ST AF, MWM-10ST BF, MWR-14ST CF, ETC.)

MATERIAL CODES: ST = CARBON STEEL. SQ = 17-7 PH/C STAINLESS STEEL. SPECIAL ALLOYS AVAILABLE UPON REQUEST.

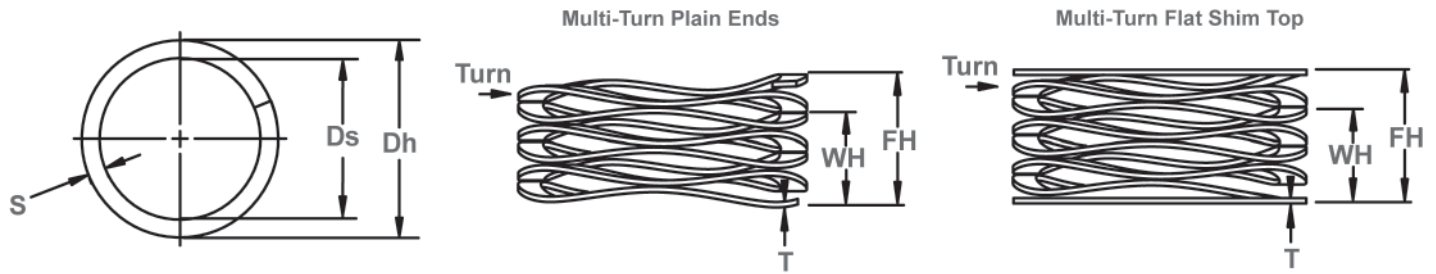

Wave Spring Measurements

WAVE SPRING NO.	PILOTS & OPERATES IN HOUSING DIAMETER		SHAFT DIAMETER CLEARANCE	LOAD (N)	WORK HEIGHT	FREE HEIGHT Ref.	NUMBER OF WAVES	NUMBER OF TURNS	THICKNESS	SECTION	SPRING RATE Ref. N/mm
	Dh mm	Ds									
MWL-15 A	15	11	25	2.57	5.18	2.5	3	0.25	1.47	9.56	
MWL-15 B	15	11	25	3.43	6.91	2.5	4	0.25	1.47	7.18	
MWL-15 C	15	11	25	4.27	8.64	2.5	5	0.25	1.47	5.72	
MWL-15 D	15	11	25	5.13	10.36	2.5	6	0.25	1.47	4.78	
MWL-15 E	15	11	25	5.99	12.09	2.5	7	0.25	1.47	4.10	
MWL-15 F	15	11	25	6.83	13.82	2.5	8	0.25	1.47	3.58	
MWL-15 G	15	11	25	7.70	15.54	2.5	9	0.25	1.47	3.19	
MWL-15 H	15	11	25	8.53	17.27	2.5	10	0.25	1.47	2.86	
MWL-15 I	15	11	25	9.40	19.00	2.5	11	0.25	1.47	2.60	
MWM-15 A	15	10	50	3.43	5.18	3.5	3	0.23	1.47	28.53	
MWM-15 B	15	10	50	4.57	6.91	3.5	4	0.23	1.47	21.40	
MWM-15 C	15	10	50	5.72	8.64	3.5	5	0.23	1.47	17.12	
MWM-15 D	15	10	50	6.86	10.36	3.5	6	0.23	1.47	14.26	
MWM-15 E	15	10	50	8.00	12.09	3.5	7	0.23	1.47	12.23	
MWM-15 F	15	10	50	9.14	13.82	3.5	8	0.23	1.47	10.70	
MWM-15 G	15	10	50	10.29	15.54	3.5	9	0.23	1.47	9.51	
MWM-15 H	15	10	50	11.43	17.27	3.5	10	0.23	1.47	8.56	
MWM-15 I	15	10	50	12.57	19.00	3.5	11	0.23	1.47	7.78	
MWR-15 A	15	10	80	3.20	5.18	3.5	3	0.25	1.47	40.38	
MWR-15 B	15	10	80	4.19	6.91	3.5	4	0.25	1.47	29.44	
MWR-15 C	15	10	80	5.23	8.64	3.5	5	0.25	1.47	23.50	
MWR-15 D	15	10	80	6.27	10.36	3.5	6	0.25	1.47	19.56	
MWR-15 E	15	10	80	7.32	12.09	3.5	7	0.25	1.47	16.75	
MWR-15 F	15	10	80	8.36	13.82	3.5	8	0.25	1.47	14.65	
MWR-15 G	15	10	80	9.40	15.54	3.5	9	0.25	1.47	13.01	
MWR-15 H	15	10	80	10.46	17.27	3.5	10	0.25	1.47	11.75	
MWR-15 I	15	10	80	11.51	19.00	3.5	11	0.25	1.47	10.68	
MWL-16 A	16	11	25	2.11	5.41	2.5	3	0.25	1.47	7.57	
MWL-16 B	16	11	25	2.79	7.21	2.5	4	0.25	1.47	5.66	
MWL-16 C	16	11	25	3.51	9.02	2.5	5	0.25	1.47	4.54	
MWL-16 D	16	11	25	4.19	10.82	2.5	6	0.25	1.47	3.77	
MWL-16 E	16	11	25	4.90	12.62	2.5	7	0.25	1.47	3.24	
MWL-16 F	16	11	25	6.30	16.23	2.5	9	0.25	1.47	2.52	
MWL-16 G	16	11	25	7.70	19.84	2.5	11	0.25	1.47	2.06	
MWL-16 H	16	11	25	9.09	23.44	2.5	13	0.25	1.47	1.74	

ALL DIMENSIONS IN MILLIMETERS UNLESS OTHERWISE SPECIFIED.

PART NUMBERS SHOWN REFLECT MULTI-TURN WAVE SPRINGS WITH PLAIN ENDS.

THE LETTERS SHOWN AFTER THE PART NUMBERS REPRESENT THE NUMBER OF TURNS. WHEN ORDERING, PARTS SHOULD BE PRESENTED WITH THE PART NUMBER, FOLLOWED BY THE MATERIAL, AND THEN THE NUMBER OF TURNS (i.e. MWL-8ST A, MWM-10ST B, MWR-14ST C, ETC.)

FOR FLAT SHIM TOP WAVE SPRINGS, ADD AN 'F' TO THE END OF THE PART NUMBER (i.e. MWL-8ST AF, MWM-10ST BF, MWR-14ST CF, ETC.)

MATERIAL CODES: ST = CARBON STEEL. SQ = 17-7 PH/C STAINLESS STEEL. SPECIAL ALLOYS AVAILABLE UPON REQUEST.

# MWL, MWM, MWR Wave Springs

## Multi Turn, Metric

Used for low to medium force applications with greater travel compared to single-turn springs. Utilizes nearly half the space as helical compression springs while producing the same force.

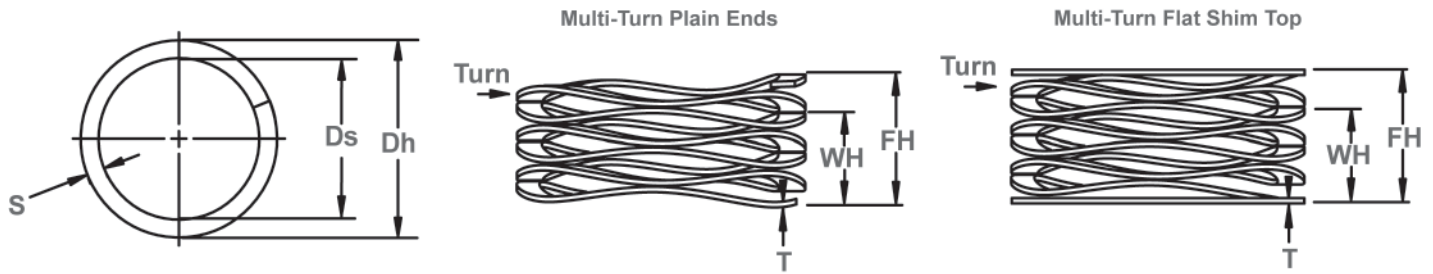

Wave Spring Measurements

WAVE SPRING NO.	PILOTS & OPERATES IN HOUSING DIAMETER	SHAFT DIAMETER CLEARANCE	LOAD (N)	WORK HEIGHT	FREE HEIGHT Ref.	NUMBER OF WAVES	NUMBER OF TURNS	THICKNESS	SECTION	SPRING RATE Ref. N/mm
	Dh mm			Ds	WH			FH	T	
MWM-16 A	16	11	55	3.63	5.41	3.5	3	0.25	1.47	30.93
MWM-16 B	16	11	55	4.83	7.21	3.5	4	0.25	1.47	23.04
MWM-16 C	16	11	55	6.05	9.02	3.5	5	0.25	1.47	18.51
MWM-16 D	16	11	55	7.24	10.82	3.5	6	0.25	1.47	15.36
MWM-16 E	16	11	55	8.46	12.62	3.5	7	0.25	1.47	13.20
MWM-16 F	16	11	55	10.87	16.23	3.5	9	0.25	1.47	10.26
MWM-16 G	16	11	55	13.28	19.84	3.5	11	0.25	1.47	8.39
MWM-16 H	16	11	55	15.70	23.44	3.5	13	0.25	1.47	7.10
MWR-16 A	16	11	90	3.30	5.41	3.5	3	0.30	1.52	42.69
MWR-16 B	16	11	90	4.57	7.21	3.5	4	0.30	1.52	34.07
MWR-16 C	16	11	90	5.59	9.02	3.5	5	0.30	1.52	26.25
MWR-16 D	16	11	90	6.86	10.82	3.5	6	0.30	1.52	22.71
MWR-16 E	16	11	90	7.87	12.62	3.5	7	0.30	1.52	18.95
MWR-16 F	16	11	90	10.16	16.23	3.5	9	0.30	1.52	14.83
MWR-16 G	16	11	90	12.45	19.84	3.5	11	0.30	1.52	12.18
MWR-16 H	16	11	90	14.73	23.44	3.5	13	0.30	1.52	10.33
MWL-18 A	18	13	30	3.63	5.72	3.5	3	0.20	1.80	14.40
MWL-18 B	18	13	30	4.75	7.62	3.5	4	0.20	1.80	10.45
MWL-18 C	18	13	30	5.94	9.53	3.5	5	0.20	1.80	8.38
MWL-18 D	18	13	30	7.14	11.43	3.5	6	0.20	1.80	6.99
MWL-18 E	18	13	30	8.31	13.34	3.5	7	0.20	1.80	5.97
MWL-18 F	18	13	30	10.69	17.15	3.5	9	0.20	1.80	4.65
MWL-18 G	18	13	30	14.25	22.86	3.5	12	0.20	1.80	3.48
MWM-18 A	18	13	55	3.68	5.72	3.5	3	0.25	1.83	27.07
MWM-18 B	18	13	55	4.98	7.62	3.5	4	0.25	1.83	20.82
MWM-18 C	18	13	55	6.22	9.53	3.5	5	0.25	1.83	16.66
MWM-18 D	18	13	55	7.47	11.43	3.5	6	0.25	1.83	13.88
MWM-18 E	18	13	55	8.74	13.34	3.5	7	0.25	1.83	11.96
MWM-18 F	18	13	55	11.23	17.15	3.5	9	0.25	1.83	9.29
MWM-18 G	18	13	55	14.96	22.86	3.5	12	0.25	1.83	6.96
MWR-18 A	18	13	90	3.84	5.72	3.5	3	0.30	1.83	47.88
MWR-18 B	18	13	90	5.13	7.62	3.5	4	0.30	1.83	36.16
MWR-18 C	18	13	90	6.40	9.53	3.5	5	0.30	1.83	28.81
MWR-18 D	18	13	90	7.70	11.43	3.5	6	0.30	1.83	24.10
MWR-18 E	18	13	90	8.97	13.34	3.5	7	0.30	1.83	20.60
MWR-18 F	18	13	90	11.53	17.15	3.5	9	0.30	1.83	16.03
MWR-18 G	18	13	90	15.37	22.86	3.5	12	0.30	1.83	12.01

ALL DIMENSIONS IN MILLIMETERS UNLESS OTHERWISE SPECIFIED.

PART NUMBERS SHOWN REFLECT MULTI-TURN WAVE SPRINGS WITH PLAIN ENDS.

THE LETTERS SHOWN AFTER THE PART NUMBERS REPRESENT THE NUMBER OF TURNS. WHEN ORDERING, PARTS SHOULD BE PRESENTED WITH THE PART NUMBER, FOLLOWED BY THE MATERIAL, AND THEN THE NUMBER OF TURNS (i.e. MWL-8ST A, MWM-10ST B, MWR-14ST C, ETC.)

FOR FLAT SHIM TOP WAVE SPRINGS, ADD AN 'F' TO THE END OF THE PART NUMBER (i.e. MWL-8ST AF, MWM-10ST BF, MWR-14ST CF, ETC.)

MATERIAL CODES: ST = CARBON STEEL. SQ = 17-7 PH/C STAINLESS STEEL. SPECIAL ALLOYS AVAILABLE UPON REQUEST.

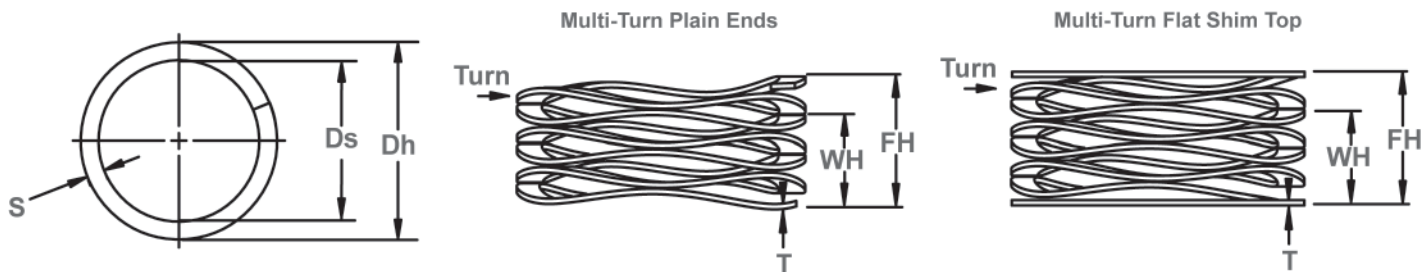

Wave Spring Measurements

WAVE SPRING NO.	PILOTS & OPERATES IN HOUSING DIAMETER		SHAFT DIAMETER CLEARANCE	LOAD (N)	WORK HEIGHT	FREE HEIGHT Ref.	NUMBER OF WAVES	NUMBER OF TURNS	THICKNESS	SECTION	SPRING RATE Ref. N/mm
	Dh mm	Ds			WH	FH			T	S	
MWL-20 A	20	15	35	35	2.72	6.32	3.5	3	0.20	1.80	9.70
MWL-20 B	20	15	35	35	3.61	8.43	3.5	4	0.20	1.80	7.25
MWL-20 C	20	15	35	35	4.52	10.54	3.5	5	0.20	1.80	5.81
MWL-20 D	20	15	35	35	5.41	12.65	3.5	6	0.20	1.80	4.83
MWL-20 E	20	15	35	35	6.32	14.76	3.5	7	0.20	1.80	4.15
MWL-20 F	20	15	35	35	8.13	18.97	3.5	9	0.20	1.80	3.23
MWL-20 G	20	15	35	35	10.82	25.30	3.5	12	0.20	1.80	2.42
MWM-20 A	20	14	70	70	3.05	6.32	3.5	3	0.25	1.98	21.36
MWM-20 B	20	14	70	70	4.06	8.43	3.5	4	0.25	1.98	16.02
MWM-20 C	20	14	70	70	5.08	10.54	3.5	5	0.25	1.98	12.82
MWM-20 D	20	14	70	70	6.27	12.65	3.5	6	0.25	1.98	10.98
MWM-20 E	20	14	70	70	7.32	14.76	3.5	7	0.25	1.98	9.41
MWM-20 F	20	14	70	70	9.17	18.97	3.5	9	0.25	1.98	7.14
MWM-20 G	20	14	70	70	12.22	25.30	3.5	12	0.25	1.98	5.35
MWR-20 A	20	14	100	100	4.24	6.32	3.5	3	0.33	2.01	48.01
MWR-20 B	20	14	100	100	5.66	8.43	3.5	4	0.33	2.01	36.12
MWR-20 C	20	14	100	100	7.06	10.54	3.5	5	0.33	2.01	28.74
MWR-20 D	20	14	100	100	8.48	12.65	3.5	6	0.33	2.01	24.01
MWR-20 E	20	14	100	100	9.91	14.76	3.5	7	0.33	2.01	20.61
MWR-20 F	20	14	100	100	12.73	18.97	3.5	9	0.33	2.01	16.00
MWR-20 G	20	14	100	100	16.97	25.30	3.5	12	0.33	2.01	12.00
MWL-25 A	25	19	50	50	2.06	6.63	3.5	3	0.25	2.18	10.94
MWL-25 B	25	19	50	50	2.74	8.84	3.5	4	0.25	2.18	8.20
MWL-25 C	25	19	50	50	3.43	11.05	3.5	5	0.25	2.18	6.56
MWL-25 D	25	19	50	50	4.11	13.26	3.5	6	0.25	2.18	5.47
MWL-25 E	25	19	50	50	4.80	15.47	3.5	7	0.25	2.18	4.69
MWL-25 F	25	19	50	50	6.20	19.89	3.5	9	0.25	2.18	3.65
MWL-25 G	25	19	50	50	8.26	26.52	3.5	12	0.25	2.18	2.74
MWM-25 A	25	19	80	80	2.95	6.63	3.5	3	0.30	2.39	21.72
MWM-25 B	25	19	80	80	3.94	8.84	3.5	4	0.30	2.39	16.32
MWM-25 C	25	19	80	80	4.90	11.05	3.5	5	0.30	2.39	13.01
MWM-25 D	25	19	80	80	5.89	13.26	3.5	6	0.30	2.39	10.86
MWM-25 E	25	19	80	80	6.88	15.47	3.5	7	0.30	2.39	9.32
MWM-25 F	25	19	80	80	8.84	19.89	3.5	9	0.30	2.39	7.24
MWM-25 G	25	19	80	80	11.79	26.52	3.5	12	0.30	2.39	5.43

ALL DIMENSIONS IN MILLIMETERS UNLESS OTHERWISE SPECIFIED.

PART NUMBERS SHOWN REFLECT MULTI-TURN WAVE SPRINGS WITH PLAIN ENDS.

THE LETTERS SHOWN AFTER THE PART NUMBERS REPRESENT THE NUMBER OF TURNS. WHEN ORDERING, PARTS SHOULD BE PRESENTED WITH THE PART NUMBER, FOLLOWED BY THE MATERIAL, AND THEN THE NUMBER OF TURNS (i.e. MWL-8ST A, MWM-10ST B, MWR-14ST C, ETC.)

FOR FLAT SHIM TOP WAVE SPRINGS, ADD AN 'F' TO THE END OF THE PART NUMBER (i.e. MWL-8ST AF, MWM-10ST BF, MWR-14ST CF, ETC.)

MATERIAL CODES: ST = CARBON STEEL. SQ = 17-7 PH/C STAINLESS STEEL. SPECIAL ALLOYS AVAILABLE UPON REQUEST.

# MWL, MWM, MWR Wave Springs

## Multi Turn, Metric

Used for low to medium force applications with greater travel compared to single-turn springs. Utilizes nearly half the space as helical compression springs while producing the same force.

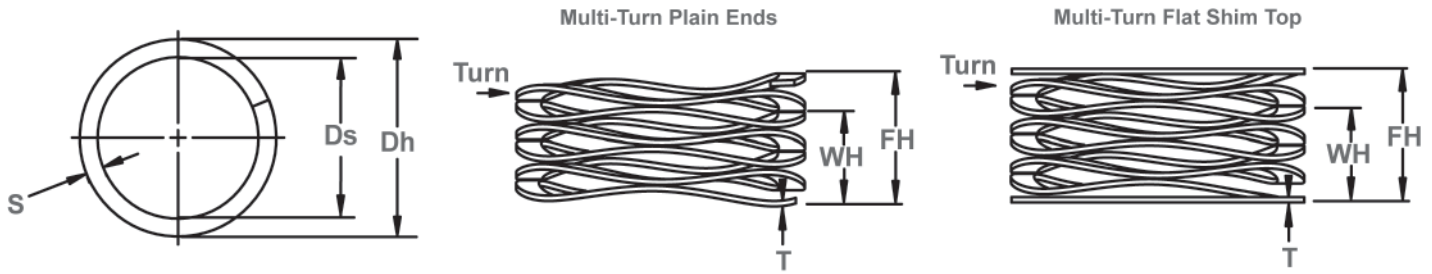

Wave Spring Measurements

WAVE SPRING NO.	PILOTS & OPERATES IN HOUSING DIAMETER		SHAFT DIAMETER CLEARANCE	LOAD (N)	WORK HEIGHT	FREE HEIGHT Ref.	NUMBER OF WAVES	NUMBER OF TURNS	THICKNESS	SECTION	SPRING RATE Ref. N/mm
	Dh mm	Ds									
MWR-25 A	25	19	110	4.04	6.63	3.5	3	0.38	2.39	42.46	
MWR-25 B	25	19	110	5.38	8.84	3.5	4	0.38	2.39	31.84	
MWR-25 C	25	19	110	6.73	11.05	3.5	5	0.38	2.39	25.47	
MWR-25 D	25	19	110	8.08	13.26	3.5	6	0.38	2.39	21.23	
MWR-25 E	25	19	110	9.40	15.47	3.5	7	0.38	2.39	18.12	
MWR-25 F	25	19	110	12.12	19.89	3.5	9	0.38	2.39	14.15	
MWR-25 G	25	19	110	16.15	26.52	3.5	12	0.38	2.39	10.61	
MWL-28 A	28	22	50	3.76	7.24	3.5	3	0.30	2.39	14.37	
MWL-28 B	28	22	50	5.00	9.65	3.5	4	0.30	2.39	10.76	
MWL-28 C	28	22	50	6.27	12.07	3.5	5	0.30	2.39	8.63	
MWL-28 D	28	22	50	7.52	14.48	3.5	6	0.30	2.39	7.18	
MWL-28 E	28	22	50	8.79	16.89	3.5	7	0.30	2.39	6.17	
MWL-28 F	28	22	50	10.03	19.30	3.5	8	0.30	2.39	5.39	
MWL-28 G	28	22	50	11.28	21.72	3.5	9	0.30	2.39	4.79	
MWL-28 H	28	22	50	13.79	26.54	3.5	11	0.30	2.39	3.92	
MWL-28 I	28	22	50	16.31	31.37	3.5	13	0.30	2.39	3.32	
MWM-28 A	28	22	80	4.39	7.24	3.5	3	0.38	2.39	28.12	
MWM-28 B	28	22	80	5.84	9.65	3.5	4	0.38	2.39	21.00	
MWM-28 C	28	22	80	7.32	12.07	3.5	5	0.38	2.39	16.84	
MWM-28 D	28	22	80	8.79	14.48	3.5	6	0.38	2.39	14.06	
MWM-28 E	28	22	80	10.24	16.89	3.5	7	0.38	2.39	12.02	
MWM-28 F	28	22	80	11.71	19.30	3.5	8	0.38	2.39	10.53	
MWM-28 G	28	22	80	13.18	21.72	3.5	9	0.38	2.39	9.37	
MWM-28 H	28	22	80	16.10	26.54	3.5	11	0.38	2.39	7.66	
MWM-28 I	28	22	80	19.02	31.37	3.5	13	0.38	2.39	6.48	
MWR-28 A	28	22	130	4.57	7.24	3.5	3	0.46	2.39	48.74	
MWR-28 B	28	22	130	6.07	9.65	3.5	4	0.46	2.39	36.30	
MWR-28 C	28	22	130	7.59	12.07	3.5	5	0.46	2.39	29.08	
MWR-28 D	28	22	130	9.12	14.48	3.5	6	0.46	2.39	24.26	
MWR-28 E	28	22	130	10.64	16.89	3.5	7	0.46	2.39	20.81	
MWR-28 F	28	22	130	12.17	19.30	3.5	8	0.46	2.39	18.21	
MWR-28 G	28	22	130	13.69	21.72	3.5	9	0.46	2.39	16.20	
MWR-28 H	28	22	130	16.71	26.54	3.5	11	0.46	2.39	13.23	
MWR-28 I	28	22	130	19.76	31.37	3.5	13	0.46	2.39	11.20	

ALL DIMENSIONS IN MILLIMETERS UNLESS OTHERWISE SPECIFIED.

PART NUMBERS SHOWN REFLECT MULTI-TURN WAVE SPRINGS WITH PLAIN ENDS.

THE LETTERS SHOWN AFTER THE PART NUMBERS REPRESENT THE NUMBER OF TURNS. WHEN ORDERING, PARTS SHOULD BE PRESENTED WITH THE PART NUMBER, FOLLOWED BY THE MATERIAL, AND THEN THE NUMBER OF TURNS (i.e. MWL-8ST A, MWM-10ST B, MWR-14ST C, ETC.)

FOR FLAT SHIM TOP WAVE SPRINGS, ADD AN 'F' TO THE END OF THE PART NUMBER (i.e. MWL-8ST AF, MWM-10ST BF, MWR-14ST CF, ETC.)

MATERIAL CODES: ST = CARBON STEEL. SQ = 17-7 PH/C STAINLESS STEEL. SPECIAL ALLOYS AVAILABLE UPON REQUEST.



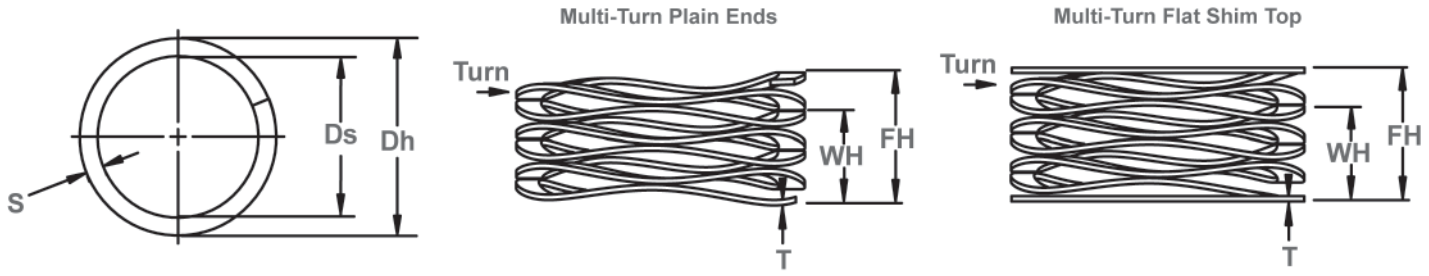

Wave Spring Measurements

WAVE SPRING NO.	PILOTS & OPERATES IN HOUSING DIAMETER		SHAFT DIAMETER CLEARANCE	LOAD (N)	WORK HEIGHT	FREE HEIGHT Ref.	NUMBER OF WAVES	NUMBER OF TURNS	THICKNESS	SECTION	SPRING RATE Ref. N/mm
	Dh mm	Ds									
MWL-30 A	30	24	50	3.18	7.62	3.5	3	0.30	2.39	11.25	
MWL-30 B	30	24	50	4.22	10.16	3.5	4	0.30	2.39	8.41	
MWL-30 C	30	24	50	5.28	12.70	3.5	5	0.30	2.39	6.74	
MWL-30 D	30	24	50	6.32	15.24	3.5	6	0.30	2.39	5.61	
MWL-30 E	30	24	50	7.39	17.78	3.5	7	0.30	2.39	4.81	
MWL-30 F	30	24	50	8.43	20.32	3.5	8	0.30	2.39	4.21	
MWL-30 G	30	24	50	9.50	22.86	3.5	9	0.30	2.39	3.74	
MWL-30 H	30	24	50	11.61	27.94	3.5	11	0.30	2.39	3.06	
MWL-30 I	30	24	50	13.72	33.02	3.5	13	0.30	2.39	2.59	
MWM-30 A	30	24	90	3.51	7.62	3.5	3	0.38	2.39	21.87	
MWM-30 B	30	24	90	4.70	10.16	3.5	4	0.38	2.39	16.48	
MWM-30 C	30	24	90	5.87	12.70	3.5	5	0.38	2.39	13.17	
MWM-30 D	30	24	90	7.04	15.24	3.5	6	0.38	2.39	10.97	
MWM-30 E	30	24	90	8.20	17.78	3.5	7	0.38	2.39	9.40	
MWM-30 F	30	24	90	9.37	20.32	3.5	8	0.38	2.39	8.22	
MWM-30 G	30	24	90	10.54	22.86	3.5	9	0.38	2.39	7.31	
MWM-30 H	30	24	90	12.90	27.94	3.5	11	0.38	2.39	5.99	
MWM-30 I	30	24	90	15.24	33.02	3.5	13	0.38	2.39	5.06	
MWR-30 A	30	24	130	4.19	7.62	3.5	3	0.46	2.39	37.91	
MWR-30 B	30	24	130	5.59	10.16	3.5	4	0.46	2.39	28.43	
MWR-30 C	30	24	130	6.99	12.70	3.5	5	0.46	2.39	22.75	
MWR-30 D	30	24	130	8.38	15.24	3.5	6	0.46	2.39	18.96	
MWR-30 E	30	24	130	9.78	17.78	3.5	7	0.46	2.39	16.25	
MWR-30 F	30	24	130	11.18	20.32	3.5	8	0.46	2.39	14.22	
MWR-30 G	30	24	130	12.57	22.86	3.5	9	0.46	2.39	12.64	
MWR-30 H	30	24	130	15.37	27.94	3.5	11	0.46	2.39	10.34	
MWR-30 I	30	24	130	18.16	33.02	3.5	13	0.46	2.39	8.75	
MWL-35 A	35	27	70	3.94	8.38	3.5	3	0.36	3.18	15.75	
MWL-35 B	35	27	70	5.23	11.18	3.5	4	0.36	3.18	11.78	
MWL-35 C	35	27	70	6.55	13.97	3.5	5	0.36	3.18	9.44	
MWL-35 D	35	27	70	7.87	16.76	3.5	6	0.36	3.18	7.87	
MWL-35 E	35	27	70	9.17	19.56	3.5	7	0.36	3.18	6.74	
MWL-35 F	35	27	70	10.49	22.35	3.5	8	0.36	3.18	5.90	
MWL-35 G	35	27	70	11.81	25.15	3.5	9	0.36	3.18	5.25	
MWL-35 H	35	27	70	14.43	30.73	3.5	11	0.36	3.18	4.29	
MWL-35 I	35	27	70	17.04	36.32	3.5	13	0.36	3.18	3.63	

ALL DIMENSIONS IN MILLIMETERS UNLESS OTHERWISE SPECIFIED.

PART NUMBERS SHOWN REFLECT MULTI-TURN WAVE SPRINGS WITH PLAIN ENDS.

THE LETTERS SHOWN AFTER THE PART NUMBERS REPRESENT THE NUMBER OF TURNS. WHEN ORDERING, PARTS SHOULD BE PRESENTED WITH THE PART NUMBER, FOLLOWED BY THE MATERIAL, AND THEN THE NUMBER OF TURNS (i.e. MWL-8ST A, MWM-10ST B, MWR-14ST C, ETC.)

FOR FLAT SHIM TOP WAVE SPRINGS, ADD AN 'F' TO THE END OF THE PART NUMBER (i.e. MWL-8ST AF, MWM-10ST BF, MWR-14ST CF, ETC.)

MATERIAL CODES: ST = CARBON STEEL. SQ = 17-7 PH/C STAINLESS STEEL. SPECIAL ALLOYS AVAILABLE UPON REQUEST.

# MWL, MWM, MWR Wave Springs

## Multi Turn, Metric

Used for low to medium force applications with greater travel compared to single-turn springs. Utilizes nearly half the space as helical compression springs while producing the same force.

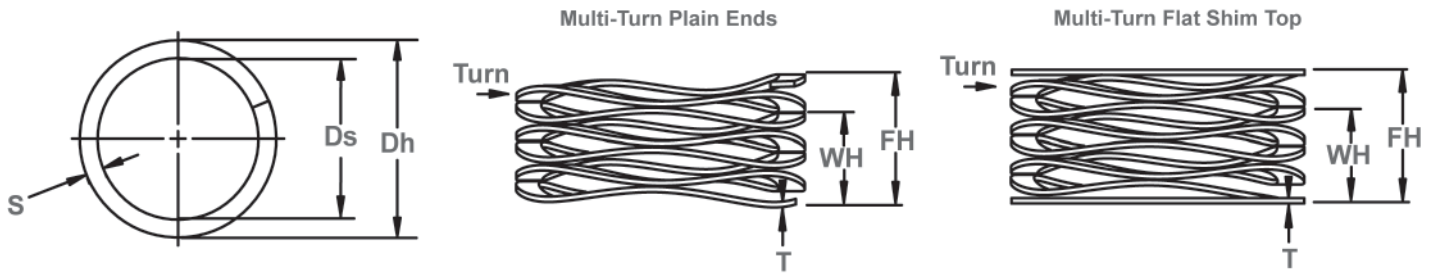

Wave Spring Measurements

WAVE SPRING NO.	PILOTS & OPERATES IN HOUSING DIAMETER		SHAFT DIAMETER CLEARANCE	LOAD (N)	WORK HEIGHT	FREE HEIGHT Ref.	NUMBER OF WAVES	NUMBER OF TURNS	THICKNESS	SECTION	SPRING RATE Ref. N/mm
	Dh mm	Ds							T	S	
MWM-35 A	35	27	110	4.14	8.38	3.5	3	0.41	3.38	25.93	
MWM-35 B	35	27	110	5.51	11.18	3.5	4	0.41	3.38	19.42	
MWM-35 C	35	27	110	6.88	13.97	3.5	5	0.41	3.38	15.52	
MWM-35 D	35	27	110	8.26	16.76	3.5	6	0.41	3.38	12.93	
MWM-35 E	35	27	110	9.63	19.56	3.5	7	0.41	3.38	11.08	
MWM-35 F	35	27	110	11.02	22.35	3.5	8	0.41	3.38	9.71	
MWM-35 G	35	27	110	12.40	25.15	3.5	9	0.41	3.38	8.63	
MWM-35 H	35	27	110	15.14	30.73	3.5	11	0.41	3.38	7.05	
MWM-35 I	35	27	110	17.91	36.32	3.5	13	0.41	3.38	5.97	
MWR-35 A	35	27	160	4.04	8.38	3.5	3	0.46	3.38	36.84	
MWR-35 B	35	27	160	5.38	11.18	3.5	4	0.46	3.38	27.63	
MWR-35 C	35	27	160	6.73	13.97	3.5	5	0.46	3.38	22.10	
MWR-35 D	35	27	160	8.08	16.76	3.5	6	0.46	3.38	18.42	
MWR-35 E	35	27	160	9.42	19.56	3.5	7	0.46	3.38	15.79	
MWR-35 F	35	27	160	10.77	22.35	3.5	8	0.46	3.38	13.81	
MWR-35 G	35	27	160	12.12	25.15	3.5	9	0.46	3.38	12.28	
MWR-35 H	35	27	160	14.81	30.73	3.5	11	0.46	3.38	10.05	
MWR-35 I	35	27	160	17.50	36.32	3.5	13	0.46	3.38	8.50	
MWL-40 A	40	30	100	2.90	9.14	3.5	3	0.41	3.38	16.00	
MWL-40 B	40	30	100	3.86	12.19	3.5	4	0.41	3.38	12.00	
MWL-40 C	40	30	100	4.80	15.24	3.5	5	0.41	3.38	9.58	
MWL-40 D	40	30	100	5.77	18.29	3.5	6	0.41	3.38	7.99	
MWL-40 E	40	30	100	6.73	21.34	3.5	7	0.41	3.38	6.85	
MWL-40 F	40	30	100	7.70	24.38	3.5	8	0.41	3.38	5.99	
MWL-40 G	40	30	100	8.66	27.43	3.5	9	0.41	3.38	5.33	
MWL-40 H	40	30	100	10.59	33.53	3.5	11	0.41	3.38	4.36	
MWL-40 I	40	30	100	12.52	39.62	3.5	13	0.41	3.38	3.69	
MWM-40 A	40	30	150	5.44	9.14	3.5	3	0.53	3.63	40.45	
MWM-40 B	40	30	150	7.24	12.19	3.5	4	0.53	3.63	30.28	
MWM-40 C	40	30	150	9.04	15.24	3.5	5	0.53	3.63	24.20	
MWM-40 D	40	30	150	10.85	18.29	3.5	6	0.53	3.63	20.16	
MWM-40 E	40	30	150	12.65	21.34	3.5	7	0.53	3.63	17.27	
MWM-40 F	40	30	150	14.48	24.38	3.5	8	0.53	3.63	15.14	
MWM-40 G	40	30	150	16.28	27.43	3.5	9	0.53	3.63	13.45	
MWM-40 H	40	30	150	19.89	33.53	3.5	11	0.53	3.63	11.00	
MWM-40 I	40	30	150	23.50	39.62	3.5	13	0.53	3.63	9.30	

ALL DIMENSIONS IN MILLIMETERS UNLESS OTHERWISE SPECIFIED.

PART NUMBERS SHOWN REFLECT MULTI-TURN WAVE SPRINGS WITH PLAIN ENDS.

THE LETTERS SHOWN AFTER THE PART NUMBERS REPRESENT THE NUMBER OF TURNS. WHEN ORDERING, PARTS SHOULD BE PRESENTED WITH THE PART NUMBER, FOLLOWED BY THE MATERIAL, AND THEN THE NUMBER OF TURNS (i.e. MWL-8ST A, MWM-10ST B, MWR-14ST C, ETC.)

FOR FLAT SHIM TOP WAVE SPRINGS, ADD AN 'F' TO THE END OF THE PART NUMBER (i.e. MWL-8ST AF, MWM-10ST BF, MWR-14ST CF, ETC.)

MATERIAL CODES: ST = CARBON STEEL. SQ = 17-7 PH/C STAINLESS STEEL. SPECIAL ALLOYS AVAILABLE UPON REQUEST.

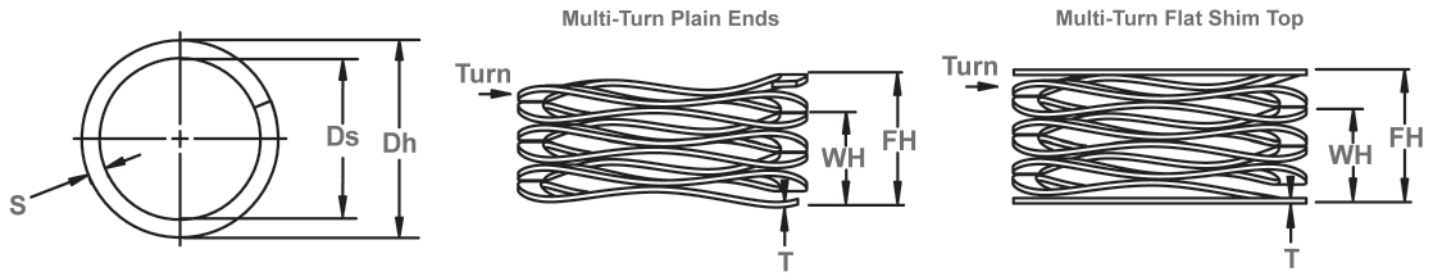

Wave Spring Measurements

WAVE SPRING NO.	PILOTS & OPERATES IN HOUSING DIAMETER	SHAFT DIAMETER CLEARANCE	LOAD (N)	WORK HEIGHT	FREE HEIGHT Ref.	NUMBER OF WAVES	NUMBER OF TURNS	THICKNESS	SECTION	SPRING RATE Ref. N/mm
								Dh mm	Ds	
MWR-40 A	40	30	300	5.66	9.14	4.5	3	0.46	3.38	86.21
MWR-40 B	40	30	300	7.54	12.19	4.5	4	0.46	3.38	64.54
MWR-40 C	40	30	300	9.42	15.24	4.5	5	0.46	3.38	51.58
MWR-40 D	40	30	300	11.33	18.29	4.5	6	0.46	3.38	43.11
MWR-40 E	40	30	300	13.21	21.34	4.5	7	0.46	3.38	36.91
MWR-40 F	40	30	300	15.09	24.38	4.5	8	0.46	3.38	32.27
MWR-40 G	40	30	300	16.97	27.43	4.5	9	0.46	3.38	28.67
MWR-40 H	40	30	300	20.75	33.53	4.5	11	0.46	3.38	23.48
MWR-40 I	40	30	300	24.54	39.62	4.5	13	0.46	3.38	19.88
MWL-45 A	45	35	110	3.38	9.91	3.5	3	0.46	3.63	16.85
MWL-45 B	45	35	110	4.52	13.21	3.5	4	0.46	3.63	12.66
MWL-45 C	45	35	110	5.64	16.51	3.5	5	0.46	3.63	10.12
MWL-45 D	45	35	110	6.76	19.81	3.5	6	0.46	3.63	8.43
MWL-45 E	45	35	110	7.90	23.11	3.5	7	0.46	3.63	7.23
MWL-45 F	45	35	110	9.02	26.42	3.5	8	0.46	3.63	6.32
MWL-45 G	45	35	110	10.16	29.72	3.5	9	0.46	3.63	5.62
MWL-45 H	45	35	110	12.40	36.32	3.5	11	0.46	3.63	4.60
MWL-45 I	45	35	110	14.66	42.93	3.5	13	0.46	3.63	3.89
MWM-45 A	45	35	225	5.33	9.91	4.5	3	0.46	3.63	49.21
MWM-45 B	45	35	225	6.99	13.21	4.5	4	0.46	3.63	36.16
MWM-45 C	45	35	225	9.14	16.51	4.5	5	0.46	3.63	30.55
MWM-45 D	45	35	225	10.80	19.81	4.5	6	0.46	3.63	24.95
MWM-45 E	45	35	225	12.70	23.11	4.5	7	0.46	3.63	21.61
MWM-45 F	45	35	225	14.48	26.42	4.5	8	0.46	3.63	18.85
MWM-45 G	45	35	225	16.26	29.72	4.5	9	0.46	3.63	16.71
MWM-45 H	45	35	225	19.81	36.32	4.5	11	0.46	3.63	13.63
MWM-45 I	45	35	225	23.37	42.93	4.5	13	0.46	3.63	11.50
MWR-45 A	45	35	400	6.43	9.91	4.5	3	0.61	3.76	114.95
MWR-45 B	45	35	400	8.38	13.21	4.5	4	0.61	3.76	82.88
MWR-45 C	45	35	400	11.20	16.51	4.5	5	0.61	3.76	75.35
MWR-45 D	45	35	400	12.95	19.81	4.5	6	0.61	3.76	58.33
MWR-45 E	45	35	400	15.37	23.11	4.5	7	0.61	3.76	51.63
MWR-45 F	45	35	400	17.27	26.42	4.5	8	0.61	3.76	43.74
MWR-45 G	45	35	400	19.68	29.72	4.5	9	0.61	3.76	39.87
MWR-45 H	45	35	400	24.26	36.32	4.5	11	0.61	3.76	33.15
MWR-45 I	45	35	400	28.45	42.93	4.5	13	0.61	3.76	27.63

ALL DIMENSIONS IN MILLIMETERS UNLESS OTHERWISE SPECIFIED.

PART NUMBERS SHOWN REFLECT MULTI-TURN WAVE SPRINGS WITH PLAIN ENDS.

THE LETTERS SHOWN AFTER THE PART NUMBERS REPRESENT THE NUMBER OF TURNS. WHEN ORDERING, PARTS SHOULD BE PRESENTED WITH THE PART NUMBER, FOLLOWED BY THE MATERIAL, AND THEN THE NUMBER OF TURNS (i.e. MWL-8ST A, MWM-10ST B, MWR-14ST C, ETC.)

FOR FLAT SHIM TOP WAVE SPRINGS, ADD AN 'F' TO THE END OF THE PART NUMBER (i.e. MWL-8ST AF, MWM-10ST BF, MWR-14ST CF, ETC.)

# MWL, MWM, MWR Wave Springs

## Multi Turn, Metric

Used for low to medium force applications with greater travel compared to single-turn springs. Utilizes nearly half the space as helical compression springs while producing the same force.

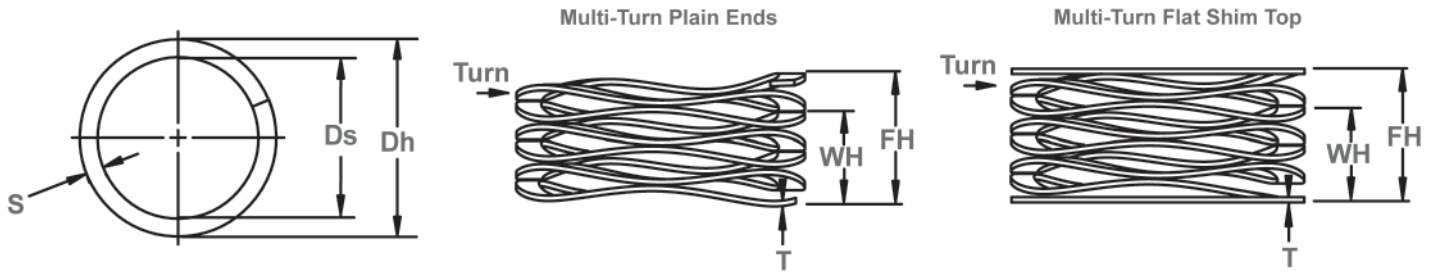

Wave Spring Measurements

WAVE SPRING NO.	PILOTS & OPERATES IN HOUSING DIAMETER	SHAFT DIAMETER CLEARANCE	LOAD (N)	WORK HEIGHT	FREE HEIGHT Ref.	NUMBER OF WAVES	NUMBER OF TURNS	THICKNESS	SECTION	SPRING RATE Ref. N/mm
				WH	FH			T	S	
	Dh mm	Ds								
MWL-50 A	50	40	110	4.83	10.29	3.5	3	0.53	3.63	20.14
MWL-50 B	50	40	110	6.10	13.72	3.5	4	0.53	3.63	14.44
MWL-50 C	50	40	110	7.87	17.15	3.5	5	0.53	3.63	11.86
MWL-50 D	50	40	110	9.40	20.57	3.5	6	0.53	3.63	9.84
MWL-50 E	50	40	110	11.30	24.00	3.5	7	0.53	3.63	8.66
MWL-50 F	50	40	110	12.70	27.43	3.5	8	0.53	3.63	7.47
MWL-50 G	50	40	110	14.99	30.86	3.5	9	0.53	3.63	6.93
MWL-50 H	50	40	110	18.16	37.72	3.5	11	0.53	3.63	5.62
MWL-50 I	50	40	110	21.34	44.58	3.5	13	0.53	3.63	4.73
MWL-50 J	50	40	110	24.64	51.44	3.5	15	0.53	3.63	4.10
MWM-50 A	50	40	225	4.62	10.29	4.5	3	0.46	3.63	39.72
MWM-50 B	50	40	225	6.35	13.72	4.5	4	0.46	3.63	30.55
MWM-50 C	50	40	225	7.49	17.15	4.5	5	0.46	3.63	23.31
MWM-50 D	50	40	225	8.89	20.57	4.5	6	0.46	3.63	19.26
MWM-50 E	50	40	225	10.54	24.00	4.5	7	0.46	3.63	16.71
MWM-50 F	50	40	225	11.89	27.43	4.5	8	0.46	3.63	14.47
MWM-50 G	50	40	225	13.59	30.86	4.5	9	0.46	3.63	13.03
MWM-50 H	50	40	225	16.71	37.72	4.5	11	0.46	3.63	10.71
MWM-50 I	50	40	225	19.61	44.58	4.5	13	0.46	3.63	9.01
MWM-50 J	50	40	225	22.48	51.44	4.5	15	0.46	3.63	7.77
MWR-50 A	50	40	400	5.92	10.29	4.5	3	0.61	3.76	91.56
MWR-50 B	50	40	400	7.80	13.72	4.5	4	0.61	3.76	67.59
MWR-50 C	50	40	400	10.16	17.15	4.5	5	0.61	3.76	57.27
MWR-50 D	50	40	400	11.79	20.57	4.5	6	0.61	3.76	45.51
MWR-50 E	50	40	400	14.15	24.00	4.5	7	0.61	3.76	40.59
MWR-50 F	50	40	400	15.62	27.43	4.5	8	0.61	3.76	33.87
MWR-50 G	50	40	400	17.91	30.86	4.5	9	0.61	3.76	30.88
MWR-50 H	50	40	400	21.54	37.72	4.5	11	0.61	3.76	24.72
MWR-50 I	50	40	400	25.65	44.58	4.5	13	0.61	3.76	21.14
MWR-50 J	50	40	400	29.21	51.44	4.5	15	0.61	3.76	18.00
MWL-55 A	55	45	125	5.59	11.05	3.5	3	0.61	3.76	22.89
MWL-55 B	55	45	125	7.72	14.73	3.5	4	0.61	3.76	17.83
MWL-55 C	55	45	125	9.68	18.41	3.5	5	0.61	3.76	14.31
MWL-55 D	55	45	125	11.48	22.1	3.5	6	0.61	3.76	11.77
MWL-55 E	55	45	125	13.92	25.78	3.5	7	0.61	3.76	10.54
MWL-55 F	55	45	125	15.52	29.46	3.5	8	0.61	3.76	8.96
MWL-55 G	55	45	125	18.41	33.15	3.5	9	0.61	3.76	8.48
MWL-55 H	55	45	125	21.67	40.51	3.5	11	0.61	3.76	6.63
MWL-55 I	55	45	125	25.65	47.88	3.5	13	0.61	3.76	5.62
MWL-55 J	55	45	125	29.77	55.25	3.5	15	0.61	3.76	4.91
MWM-55 A	55	45	250	3.1	11.05	4.5	3	0.46	3.63	31.45
MWM-55 B	55	45	250	4.11	14.73	4.5	4	0.46	3.63	23.55
MWM-55 C	55	45	250	5.16	18.41	4.5	5	0.46	3.63	18.86
MWM-55 D	55	45	250	6.2	22.1	4.5	6	0.46	3.63	15.72
MWM-55 E	55	45	250	7.21	25.78	4.5	7	0.46	3.63	13.46

ALL DIMENSIONS IN MILLIMETERS UNLESS OTHERWISE SPECIFIED.

PART NUMBERS SHOWN REFLECT MULTI-TURN WAVE SPRINGS WITH PLAIN ENDS.

THE LETTERS SHOWN AFTER THE PART NUMBERS REPRESENT THE NUMBER OF TURNS. WHEN ORDERING, PARTS SHOULD BE PRESENTED WITH THE PART NUMBER, FOLLOWED BY THE MATERIAL, AND THEN THE NUMBER OF TURNS (i.e. MWL-8ST A, MWM-10ST B, MWR-14ST C, ETC.)

FOR FLAT SHIM TOP WAVE SPRINGS, ADD AN 'F' TO THE END OF THE PART NUMBER (i.e. MWL-8ST AF, MWM-10ST BF, MWR-14ST CF, ETC.)

MATERIAL CODES: ST = CARBON STEEL. SQ = 17-7 PH/C STAINLESS STEEL. SPECIAL ALLOYS AVAILABLE UPON REQUEST.

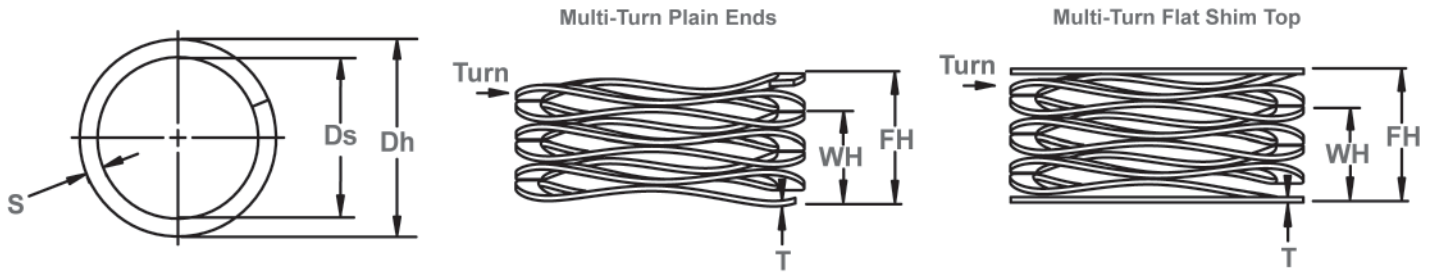

Wave Spring Measurements

WAVE SPRING NO.	PILOTS & OPERATES IN HOUSING DIAMETER		SHAFT DIAMETER CLEARANCE	LOAD (N)	WORK HEIGHT	FREE HEIGHT Ref.	NUMBER OF WAVES	NUMBER OF TURNS	THICKNESS	SECTION	SPRING RATE Ref. N/mm
	Dh mm	Ds									
					WH	FH			T	S	
MWM-55 F	55	45	250	8.26	29.46	4.5	8	0.46	3.63	11.79	
MWM-55 G	55	45	250	9.27	33.15	4.5	9	0.46	3.63	10.47	
MWM-55 H	55	45	250	11.33	40.51	4.5	11	0.46	3.63	8.57	
MWM-55 I	55	45	250	13.41	47.88	4.5	13	0.46	3.63	7.25	
MWM-55 J	55	45	250	15.47	55.25	4.5	15	0.46	3.63	6.29	
MWR-55 A	55	45	400	5.31	11.05	4.5	3	0.61	3.76	69.68	
MWR-55 B	55	45	400	7.24	14.73	4.5	4	0.61	3.76	53.38	
MWR-55 C	55	45	400	9.09	18.41	4.5	5	0.61	3.76	42.91	
MWR-55 D	55	45	400	10.64	22.1	4.5	6	0.61	3.76	34.92	
MWR-55 E	55	45	400	12.24	25.78	4.5	7	0.61	3.76	29.55	
MWR-55 F	55	45	400	14.1	29.46	4.5	8	0.61	3.76	26.03	
MWR-55 G	55	45	400	15.82	33.15	4.5	9	0.61	3.76	23.09	
MWR-55 H	55	45	400	19.3	40.51	4.5	11	0.61	3.76	18.86	
MWR-55 I	55	45	400	23.11	47.88	4.5	13	0.61	3.76	16.15	
MWR-55 J	55	45	400	26.54	55.25	4.5	15	0.61	3.76	13.94	
MWL-60 A	60	50	135	5.59	11.43	4.5	3	0.46	3.63	23.11	
MWL-60 B	60	50	135	7.47	15.24	4.5	4	0.46	3.63	17.37	
MWL-60 C	60	50	135	9.32	19.05	4.5	5	0.46	3.63	13.88	
MWL-60 D	60	50	135	11.2	22.86	4.5	6	0.46	3.63	11.58	
MWL-60 E	60	50	135	13.06	26.67	4.5	7	0.46	3.63	9.92	
MWL-60 F	60	50	135	14.94	30.48	4.5	8	0.46	3.63	8.68	
MWL-60 G	60	50	135	16.79	34.29	4.5	9	0.46	3.63	7.71	
MWL-60 H	60	50	135	20.52	41.91	4.5	11	0.46	3.63	6.31	
MWL-60 I	60	50	135	24.26	49.53	4.5	13	0.46	3.63	5.34	
MWL-60 J	60	50	135	27.99	57.15	4.5	15	0.46	3.63	4.63	
MWM-60 A	60	50	275	6.65	11.43	4.5	3	0.61	3.76	57.59	
MWM-60 B	60	50	275	8.86	15.24	4.5	4	0.61	3.76	43.13	
MWM-60 C	60	50	275	11.07	19.05	4.5	5	0.61	3.76	34.48	
MWM-60 D	60	50	275	13.28	22.86	4.5	6	0.61	3.76	28.72	
MWM-60 E	60	50	275	15.49	26.67	4.5	7	0.61	3.76	24.61	
MWM-60 F	60	50	275	17.7	30.48	4.5	8	0.61	3.76	21.52	
MWM-60 G	60	50	275	19.94	34.29	4.5	9	0.61	3.76	19.16	
MWM-60 H	60	50	275	24.36	41.91	4.5	11	0.61	3.76	15.67	
MWM-60 I	60	50	275	28.78	49.53	4.5	13	0.61	3.76	13.25	
MWM-60 J	60	50	275	33.22	57.15	4.5	15	0.61	3.76	11.49	
MWR-60 A	60	50	450	7.75	11.43	4.5	3	0.76	4.01	122.18	
MWR-60 B	60	50	450	10.31	15.24	4.5	4	0.76	4.01	91.32	
MWR-60 C	60	50	450	12.9	19.05	4.5	5	0.76	4.01	73.21	
MWR-60 D	60	50	450	15.47	22.86	4.5	6	0.76	4.01	60.88	
MWR-60 E	60	50	450	18.06	26.67	4.5	7	0.76	4.01	52.26	
MWR-60 F	60	50	450	20.62	30.48	4.5	8	0.76	4.01	45.66	
MWR-60 G	60	50	450	23.22	34.29	4.5	9	0.76	4.01	40.63	
MWR-60 H	60	50	450	28.37	41.91	4.5	11	0.76	4.01	33.24	
MWR-60 I	60	50	450	33.53	49.53	4.5	13	0.76	4.01	28.12	
MWR-60 J	60	50	450	38.68	57.15	4.5	15	0.76	4.01	24.37	

ALL DIMENSIONS IN MILLIMETERS UNLESS OTHERWISE SPECIFIED.

PART NUMBERS SHOWN REFLECT MULTI-TURN WAVE SPRINGS WITH PLAIN ENDS.

THE LETTERS SHOWN AFTER THE PART NUMBERS REPRESENT THE NUMBER OF TURNS. WHEN ORDERING, PARTS SHOULD BE PRESENTED WITH THE PART NUMBER, FOLLOWED BY THE MATERIAL, AND THEN THE NUMBER OF TURNS (i.e. MWL-8ST A, MWM-10ST B, MWR-14ST C, ETC.)

FOR FLAT SHIM TOP WAVE SPRINGS, ADD AN 'F' TO THE END OF THE PART NUMBER (i.e. MWL-8ST AF, MWM-10ST BF, MWR-14ST CF, ETC.)

MATERIAL CODES: ST = CARBON STEEL. SQ = 17-7 PH/C STAINLESS STEEL. SPECIAL ALLOYS AVAILABLE UPON REQUEST.





# KMS Shims

## Shims

Shims are typically used in order to support, adjust for better fit, or provide a level surface. Shims may also be used as spacers to fill gaps between parts subject to wear.

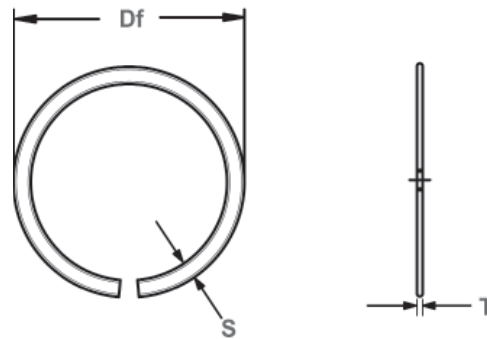

Shim Measurements

RING NO.	RING SIZE				
	FREE DIAMETER		THICKNESS	SECTION	
	Df	Tol.	T	S	
KMS-75	0.750	+.000 -.015	.024	.093	
KMS-87	0.875		.024	.093	
KMS-100	1.000		.024	.103	
KMS-112	1.125		.024	.138	
KMS-125	1.250		.024	.138	
KMS-137	1.375		.024	.138	
KMS-150	1.500		.024	.150	
KMS-162	1.625		.024	.150	
KMS-175	1.750		+.000 -.020	.024	.150
KMS-187	1.875			.024	.150
KMS-200	2.000	.024		.150	
KMS-212	2.125	.024		.150	
KMS-225	2.250	.024		.150	
KMS-237	2.375	.024		.178	
KMS-250	2.500	.024		.178	
KMS-262	2.625	+.000 -.025		.024	.178
KMS-275	2.750			.030	.188
KMS-287	2.875			.030	.188
KMS-300	3.000		.030	.188	
KMS-312	3.125		.030	.188	
KMS-325	3.250		+.000 -.030	.030	.233
KMS-337	3.375			.030	.233
KMS-350	3.500			.030	.233
KMS-362	3.625			.030	.233
KMS-375	3.750			.030	.233
KMS-387	3.875	.030		.233	
KMS-400	4.000	.030		.233	
KMS-412	4.125	.030		.233	
KMS-425	4.250	+.000 -.035		.030	.233
KMS-437	4.375			.030	.233
KMS-450	4.500		.030	.233	
KMS-462	4.625		.030	.233	
KMS-475	4.750		.030	.233	
KMS-487	4.875		.030	.233	
KMS-500	5.000		.030	.233	

RING NO.	RING SIZE				
	FREE DIAMETER		THICKNESS	SECTION	
	Df	Tol.	T	S	
KMS-512	5.125	+.000 -.035	.030	.233	
KMS-525	5.250		.030	.233	
KMS-537	5.375		.030	.233	
KMS-550	5.500		.030	.233	
KMS-562	5.625		.030	.233	
KMS-575	5.750		.030	.233	
KMS-587	5.875		+.000 -.045	.030	.233
KMS-600	6.000			.030	.233
KMS-612	6.125			.030	.233
KMS-625	6.250			.030	.233
KMS-637	6.375	.030		.233	
KMS-650	6.500	.030		.233	
KMS-675	6.750	.030		.233	
KMS-700	7.000	.032		.375	
KMS-725	7.250	+.000 -.060		.032	.375
KMS-750	7.500			.032	.375
KMS-775	7.750		.032	.375	
KMS-800	8.000		.032	.375	
KMS-825	8.250		.032	.375	
KMS-850	8.500		.032	.375	
KMS-900	9.000		+.000 -.070	.032	.375
KMS-950	9.500			.032	.375
KMS-1000	10.000			.032	.375
KMS-1050	10.500			.032	.375
KMS-1100	11.000	.032		.375	
KMS-1150	11.500	.032		.375	
KMS-1200	12.000	+.000 -.080		.032	.375
KMS-1250	12.500			.032	.375
KMS-1300	13.000			.032	.375
KMS-1350	13.500			.032	.375
KMS-1400	14.000		.032	.375	
KMS-1450	14.500		.032	.375	
KMS-1500	15.000		+.000 -.090	.032	.375
KMS-1550	15.500			.032	.375
KMS-1600	16.000			.032	.375



# Single Wire, Self-Compensating Hose Clamp

Single wire clamps have the most effective holding force and clamping strength. The single wire concentrates the clamping force in one specific area around the hose.

# HC Hose Clamps

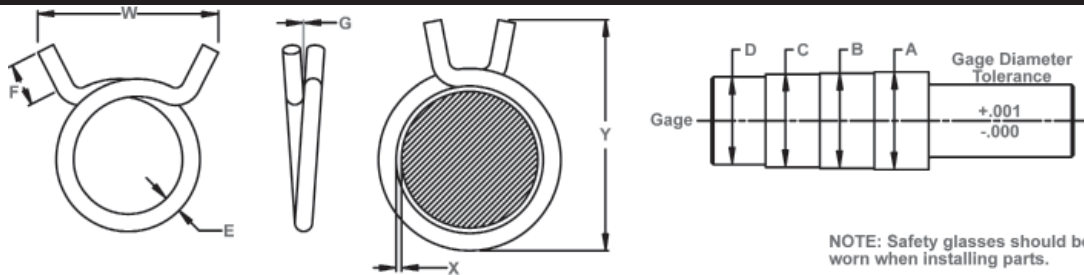

NOTE: Safety glasses should be worn when installing parts.

**EFFECTIVE CLAMPING RANGE:** After expanding to no greater than "A" diameter of the gage, the clamp in relaxed condition shall not pass over "D" diameter. When clamp is assembled on "A", "B" or "C" diameter of gage, a wire of "X" diameter shall not pass between gage and clamp when inserted in a direction parallel to the axis of the gage.

**FINISH:** Peen-Plate Zinc (non-electrolytic process) .0002 minimum thickness plus dichromate treatment. (See color codes below.)

**MATERIAL:** SAE 1060-1075, material code ST. Specially processed premium grade spring wire, hardened and austempered to meet the performance requirements specified.

Note: All Dimensions are in Inches. Conforms to SAE spec. J1508.

ROTOR CLAMP HC NO.	Case Quantity	Approx. Case Weight (lbs.)	EFFECTIVE CLAMPING RANGE				E Nom. Wire Dia.	F Length of Tangs	G Clearance at overlap Max.	W Width over Tangs Max.	X Gaging Wire Max.	Y Overall Height (Ref. Only)	Color Code *	Pneumatic Installation Tool	
			A Max. Dia.	B Nom. Dia.	C Min. Dia.	D No-Go Gage Dia.									
19N	HC-4	15000	25.7	.253	.250	.247	.233	.062	3/8	.010	.75	.003	.88	G	PWS-4
	HC-5	10000	18.6	.315	.312	.309	.286	.062	3/8	.010	.75	.003	1.00	R	PWS-5
	HC-5.5	10000	19.8	.345	.342	.339	.320	.062	3/8	.010	.75	.003	1.00	G	PWS-5.5
35N	HC-6	10000	37.9	.380	.375	.370	.350	.082	3/8	.015	.88	.004	1.06	D	PWS-6
	HC-7	8000	38.9	.442	.437	.432	.405	.087	3/8	.015	.94	.004	1.12	G	PWS-7
	HC-7.5	7500	37.5	.473	.468	.463	.430	.087	3/8	.015	1.00	.005	1.12	D	PWS-7.5
	HC-8	6000	33.7	.510	.500	.490	.462	.092	3/8	.025	1.00	.005	1.19	R	PWS-8
	HC-8.5	6000	34.8	.541	.531	.521	.492	.092	3/8	.025	1.00	.005	1.38	G	PWS-8.5
	HC-9	4500	38.0	.573	.562	.551	.520	.107	3/8	.025	1.06	.006	1.38	D	PWS-9
	HC-9.5	4500	39.0	.604	.593	.582	.550	.107	3/8	.025	1.06	.006	1.38	R	PWS-9.5
	HC-10	4000	34.8	.640	.625	.610	.580	.107	3/8	.025	1.06	.006	1.38	G	PWS-10
	HC-10.5	4000	37.6	.671	.656	.641	.611	.107	3/8	.025	1.06	.006	1.38	D	PWS-10.5
	HC-11	3500	37.0	.703	.687	.671	.635	.112	3/8	.025	1.12	.006	1.50	R	PWS-11
	HC-12	3000	33.0	.770	.750	.730	.690	.112	3/8	.031	1.19	.008	1.50	D	PWS-12
	1/2 Keg	HC-13	2500	30.7	.832	.812	.792	.740	.117	3/8	.031	1.25	.008	1.50	G
HC-14		2000	28.2	.900	.875	.850	.800	.122	3/8	.031	1.25	.008	1.62	R	PWS-14
HC-15		2000	31.0	.968	.937	.906	.855	.122	3/8	.062	1.25	.008	1.69	D	PWS-15
HC-16		1750	32.9	1.031	1.000	.969	.915	.132	3/8	.062	1.31	.008	1.75	G	PWS-16
HC-17		1400	32.6	1.090	1.062	1.034	.960	.142	3/8	.062	1.50	.010	1.88	R	PWS-17
HC-17.5		1250	32.5	1.124	1.093	1.065	.991	.152	3/8	.062	1.50	.010	1.90	R	PWS-17.5
HC-18		1000	28.0	1.150	1.125	1.100	1.030	.152	3/8	.062	1.62	.010	2.00	D	PWS-18
HC-188		1500	26.4	1.150	1.125	1.100	1.030	.122	3/8	.062	1.62	.010	2.00	D	PWS-188
HC-19		1000	28.3	1.218	1.187	1.156	1.095	.152	3/8	.062	1.62	.010	2.00	G	PWS-19
HC-19.5		1000	29.3	1.250	1.218	1.187	1.126	.152	3/8	.062	1.63	.010	2.00	R	PWS-19.5
HC-20		1000	30.0	1.280	1.250	1.219	1.145	.152	3/8	.062	1.75	.010	2.00	R	PWS-20
HC-21		800	28.8	1.344	1.312	1.281	1.210	.162	3/8	.062	1.75	.010	2.31	D	PWS-21
HC-22	800	29.6	1.406	1.375	1.344	1.250	.162	3/8	.062	1.88	.010	2.31	G	PWS-22	
HC-23	750	25.5	1.468	1.437	1.406	1.300	.162	3/8	.062	1.88	.010	2.31	R	PWS-23	
HC-24	600	23.4	1.531	1.500	1.469	1.350	.162	3/8	.062	1.88	.010	2.38	D	PWS-24	
HC-25	600	23.6	1.592	1.561	1.530	1.411	.162	3/8	.062	1.88	.010	2.53	D	PWS-25	
HC-26	600	28.8	1.672	1.625	1.578	1.455	.172	3/8	.062	2.00	.010	2.69	D	PWS-26	
HC-28	500	25.0	1.797	1.750	1.703	1.550	.172	3/8	.062	2.12	.010	2.75	D	PWS-28	
HC-30	500	29.0	1.937	1.875	1.812	1.675	.177	3/8	.093	2.25	.010	2.88	D	PWS-30	
HC-31	500	29.5	2.000	1.937	1.875	1.720	.177	3/8	.093	2.25	.010	3.00	D	PWS-31	
HC-32	500	30.0	2.061	2.000	1.939	1.750	.177	3/8	.093	2.31	.010	3.00	D	PWS-32	
HC-34	500	31.9	2.187	2.125	2.062	1.860	.182	3/8	.093	2.31	.010	3.19	D	PWS-34	
HC-35	500	34.2	2.250	2.187	2.125	1.925	.182	3/8	.093	2.31	.010	3.25	D	PWS-35	
HC-36	500	34.5	2.312	2.250	2.187	2.000	.182	3/8	.093	2.38	.010	3.25	D	PWS-36	
HC-38	500	39.5	2.437	2.375	2.312	2.100	.192	3/8	.093	2.38	.010	3.44	D	PWS-38	
HC-40	500	41.5	2.561	2.500	2.439	2.187	.192	3/8	.093	2.38	.010	3.62	D	PWS-40	
HC-42	400	39.2	2.688	2.625	2.562	2.320	.202	3/8	.093	2.38	.010	3.75	D	PWS-42	
HC-46	400	41.9	2.938	2.875	2.812	2.625	.220	3/8	.093	2.63	.012	3.88	D	PWS-46	
HC-50	400	53.8	3.218	3.125	3.032	2.844	.220	3/8	.125	3.12	.013	4.00	D	PWS-50	

\* GREEN, R-RED, D-DICHROMATE(YELLOW), NOTE: SELECTED SIZES AVAILABLE IN STAINLESS STEEL. INQUIRE FOR AVAILABILITY.





# HW Hose Clamps

## Slim Wire, Self-Compensating Hose Clamp

A slimmer version of the Single Wire Hose clamp. The single wire concentrates the clamping force in one specific area around the hose.

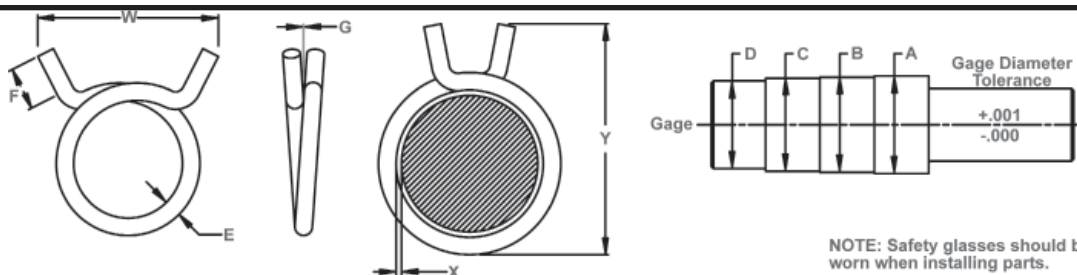

NOTE: Safety glasses should be worn when installing parts.

**EFFECTIVE CLAMPING RANGE:** After expanding to no greater than "A" diameter of the gage, the clamp in relaxed condition shall not pass over "D" diameter. When clamp is assembled on "A", "B" or "C" diameter of gage, a wire of "X" diameter shall not pass between gage and clamp when inserted in a direction parallel to the axis of the gage.

**FINISH:** Peen-Plate Zinc (non-electrolytic process) .0002 minimum thickness plus dichromate treatment. (See color codes below.)

**MATERIAL:** SAE 1060-1075, material code ST. Specially processed premium grade spring wire, hardened and austempered to meet the performance requirements specified.

Note: All Dimensions are in inches.

ROTOR CLAMP HW NO.	Case Quantity Min. 1 case	Approx. Case Weight (lbs.)	E Nom. Wire Dia.	EFFECTIVE CLAMPING RANGE				X Dia. Gaging Wire	G Clearance at overlap Max.	F Length of Tangs	W Width over Tangs Max.	Z Width over Tangs when on a Dia.		Y Overall Height (Ref. Only)	Color Code *	Pneumatic installation Tool	
				A Max. Dia.	B Nom. Dia.	C Min. Dia.	D No-Go Gage Dia.										
HW-9	8000	39	.082	.573	.562	.551	.520	.006	.025	1/4	+ .000-1/32	1-1/16	.415	+ .020-.000	1.25	ZD	PWS-9
HW-11	6000	33	.087	.703	.688	.671	.635	.006	.025	1/4	+ .000-1/32	1-1/8	.425	+ .020-.000	1.38	R	PWS-11
HW-12	5000	30	.087	.770	.750	.730	.690	.008	.031	1/4	+ .000-1/32	1-3/16	.425	+ .020-.000	1.38	ZD	PWS-12
HW-13	4000	28	.092	.832	.812	.792	.740	.008	.031	1/4	+ .000-1/32	1-1/4	.410	+ .020-.000	1.38	G	PWS-13
HW-14	3000	26	.092	.900	.875	.850	.800	.008	.031	1/4	+ .000-1/32	1-1/4	.410	+ .020-.000	1.49	R	PWS-14
HW-16	2500	29	.107	1.031	1.000	.969	.915	.008	.062	1/4	±1/32	1-1/2	.510	+ .020-.000	1.75	G	PWS-16
HW-18	1700	28	.122	1.150	1.125	1.100	1.030	.010	.062	1/4	±1/32	1-5/8	.525	+ .020-.000	1.88	ZD	PWS-18
HW-19	1400	24	.122	1.218	1.187	1.152	1.095	.010	.062	1/4	±1/32	1-5/8	.510	+ .020-.000	1.88	G	PWS-19
HW-20	1400	23	.122	1.280	1.250	1.219	1.145	.010	.062	1/4	±1/32	1-3/4	.525	+ .030-.000	1.88	R	PWS-20
HW-21	1300	28	.132	1.344	1.312	1.281	1.210	.010	.062	1/4	±1/32	1-3/4	.540	+ .030-.000	2.19	ZD	PWS-21
HW-22	1000	22	.132	1.406	1.375	1.344	1.250	.010	.062	1/4	±1/32	1-7/8	.540	+ .030-.000	2.19	G	PWS-22
HW-23	1000	23	.132	1.468	1.437	1.406	1.300	.010	.062	1/4	±1/32	1-7/8	.525	+ .030-.000	2.19	R	PWS-23
HW-24	1000	24	.132	1.531	1.500	1.469	1.350	.010	.062	1/4	+1/16-.000	1-7/8	.540	+ .030-.000	2.25	ZD	PWS-24
HW-26	900	27	.142	1.672	1.625	1.578	1.455	.010	.062	1/4	±1/16	2	.580	+ .030-.000	2.56	ZD	PWS-26

\* GREEN, R-RED, ZD-DICHROMATE (YELLOW)



# Double Wire, Self-Compensating Hose Clamp

Double wire clamps are used where a lower clamping force than offered by single wire clamps is sufficient and aesthetics are important. The double wound wire spreads out the clamping force around the hose, and are more cost effective than single wire clamps.

# DW Hose Clamps



NOTE: Safety glasses should be worn when installing parts.

**EFFECTIVE CLAMPING RANGE:** After expanding to no greater than "A" diameter of the gage, the clamp in relaxed condition shall not pass over "D" diameter. When clamp is assembled on "A", "B" or "C" diameter of gage, a wire of "X" diameter shall not pass between gage and clamp when inserted in a direction parallel to the axis of the gage.

**FINISH:** Peen-Plate Zinc (non-electrolytic process) .0002 minimum thickness plus dichromate treatment. (See color codes below.)

**MATERIAL:** SAE 1060-1075, material code ST. Specially processed premium grade spring wire, hardened and austempered to meet the performance requirements specified.

Note: All Dimensions are in Inches. Conforms to SAE spec. J1508.

ROTOR CLAMP DW No.	Case Quantity Min. 1 case	Approx. Case Weight (lbs.)	A MAX. Dia.	B NOM. Dia.	C MIN Dia.	D NO-GO GAGE Dia.	E NOM. WIRE Dia.	Ref. Dimensions		H OVER-ALL WIDTH	X GAGING WIRE	Color Code *	PNEUMATIC INSTALLATION TOOL
								F1 max.	F2 min.				
DW-4.5	10000	11	.294	.286	.274	.265	.039	.250	.190	.250	.004	D	PWD-4.5
DW-5	10000	11	.306	.301	.285	.280	.039	.250	.190	.250	.004	D	PWD-5
DW-5.5	10000	12	.345	.342	.339	.320	.039	.250	.190	.250	.004	S	PWD-5.5
DW-6	17000	22	.380	.375	.370	.350	.039	.250	.190	.250	.004	S	PWD-6
DW-6.5	8000	28	.416	.409	.401	.381	.059	.380	.250	.280	.006	D	PWD-6.5
DW-7	7000	26	.442	.438	.432	.405	.059	.380	.250	.280	.006	S	PWD-7
DW-8	7000	28	.510	.500	.490	.462	.059	.380	.250	.280	.006	R	PWD-8
DW-8.5	7000	29	.555	.539	.524	.484	.059	.380	.250	.280	.006	D	PWD-8.5
DW-9	6000	38	.573	.562	.551	.520	.070	.425	.250	.325	.006	S	PWD-9
DW-9.5	2500	34	.627	.614	.595	.555	.070	.425	.250	.325	.006	R	PWD-9.5
DW-10	4000	25	.640	.625	.610	.580	.070	.425	.250	.325	.006	G	PWD-10
DW-10.5	3000	20	.662	.646	.627	.586	.070	.425	.250	.325	.006	D	PWD-10.5
DW-11	2500	23	.703	.688	.671	.635	.078	.500	.325	.360	.008	R	PWD-11
DW-11.5	2500	24	.736	.716	.697	.650	.078	.500	.325	.360	.008	D	PWD-11.5
DW-12	2000	20	.770	.750	.730	.690	.078	.500	.325	.360	.008	S	PWD-12
DW-12.5	2000	21	.812	.795	.772	.720	.078	.500	.325	.360	.008	D	PWD-12.5
DW-13	2000	21	.832	.812	.792	.740	.078	.500	.325	.360	.008	G	PWD-13
DW-14	1500	21	.900	.875	.850	.800	.086	.550	.375	.400	.008	D	PWD-14
DW-14.5	1500	21	.928	.909	.882	.826	.086	.550	.375	.400	.008	R	PWD-14.5
DW-15	1200	17	.968	.938	.906	.855	.086	.550	.375	.400	.008	S	PWD-15
DW-16	1100	22	1.031	1.000	.969	.915	.098	.560	.375	.450	.008	D	PWD-16
DW-17	1000	21	1.090	1.062	1.034	.960	.098	.560	.375	.450	.008	R	PWD-17
DW-17.5	1000	21	1.107	1.082	1.050	.984	.098	.560	.375	.450	.008	D	PWD-17.5
DW-18	1700	37	1.150	1.125	1.100	1.030	.098	.560	.375	.450	.008	S	PWD-18
DW-19	1250	37	1.218	1.188	1.156	1.095	.110	.660	.450	.480	.010	G	PWD-19
DW-19.5	1100	33	1.260	1.232	1.196	1.117	.110	.660	.450	.480	.010	D	PWD-19.5
DW-20	1100	34	1.280	1.250	1.219	1.145	.110	.660	.450	.480	.010	R	PWD-20
DW-21	1100	35	1.344	1.312	1.281	1.210	.110	.660	.450	.480	.010	S	PWD-21
DW-22	1000	39	1.405	1.377	1.335	1.260	.118	.750	.500	.540	.010	G	PWD-22
DW-22.5	900	36	1.433	1.401	1.362	1.279	.118	.750	.500	.540	.010	S	PWD-22.5
DW-23	900	36	1.500	1.465	1.425	1.330	.118	.750	.500	.540	.010	D	PWD-23
DW-24	750	35	1.531	1.500	1.469	1.350	.126	.750	.500	.560	.010	S	PWD-24
DW-25	750	37	1.592	1.561	1.530	1.411	.126	.750	.500	.560	.010	S	PWD-25
DW-26	700	35	1.692	1.625	1.578	1.475	.126	.750	.500	.560	.010	D	PWD-26
DW-27	650	34	1.745	1.688	1.640	1.528	.126	.750	.500	.560	.010	R	PWD-27
DW-28	650	34	1.797	1.750	1.703	1.580	.126	.750	.500	.560	.010	S	PWD-28
DW-30	600	34	1.937	1.875	1.812	1.720	.126	.750	.500	.560	.010	S	PWD-30
DW-31	500	34	2.000	1.938	1.875	1.799	.137	.800	.550	.590	.010	S	PWD-31
DW-32	500	35	2.061	2.000	1.939	1.83	.137	.800	.550	.590	.010	D	PWD-32
DW-34	450	33	2.187	2.125	2.062	1.946	.137	.800	.550	.590	.010	S	PWD-34
DW-35	400	30	2.250	2.187	2.125	1.975	.137	.800	.550	.590	.010	S	PWD-35
DW-36	400	31	2.300	2.250	2.187	2.000	.137	.800	.550	.590	.010	S	PWD-36

\* G-Green, R-Red, D-Dichromate (Yellow). NOTE: SELECTED SIZES AVAILABLE IN STAINLESS STEEL. INQUIRE FOR AVAILABILITY.

\*\* MANUAL INSTALLATION TOOLS ALSO AVAILABLE.





# CTB Hose Clamps

## Constant Tension Band, Self-Compensating Hose Clamp

Constant Tension Band clamps are used in applications where a lower clamping force than offered by single wire clamps is sufficient, but a higher clamping force than produced by double wire clamps is needed.

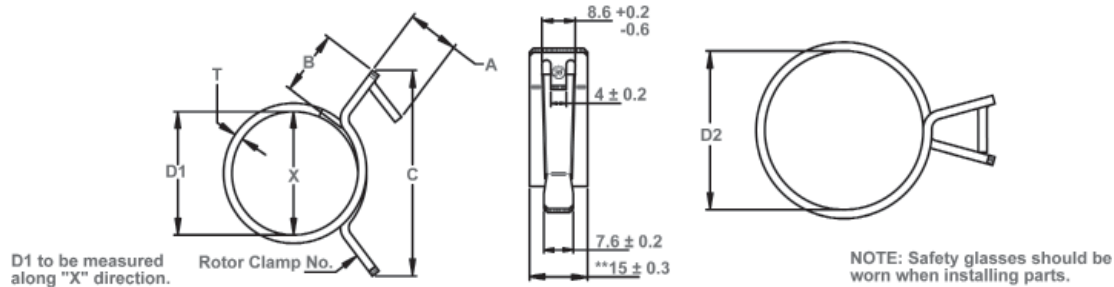

CTB Clamps should be installed/removed using the proper tool.

\*\* Contact manufacturer for availability of additional widths.

Note: Dimensions "D1" and "C" to be measured only after expanding the clamp fully one time.

**FINISH:** Zinc Rich Paint\* up to 700 hour-salt spray.

**MATERIAL:** SAE 1074 - material code ST. (Optional Material: Chrome Vanadium - DIN 17222, JIS G 4802 - material code CV. Limited availability and at our discretion.)

Note: All Dimensions are in Millimeters. Conforms to SAE spec. J1508.

ROTOR CLAMP CTB NO. (mm)	CASE QUANTITY min 1 case	WEIGHT PER M (lbs.)	WEIGHT PER CASE (lbs.)	D1 Free Dia. Max. (mm)	D2 FULL OPEN DIA. Min. (mm)	MATERIAL THICKNESS T +0.08 -0.02	REFERENCE DIMENSIONS (All Sizes Listed In mm)		
							A (mm) Tab Height	B (mm) Ear Length	C (mm) Ear Span
CTB-13	2500	8.5	21.250	12.0	14.2	0.70	7.3	11.7	27.0
CTB-14	2500	10.2	25.500	13.5	15.3	0.80	8.0	12.5	30.0
CTB-15	2500	9.35	23.375	13.9	16.8	0.70	7.2	11.9	31.0
CTB-16	2500	12.87	32.175	14.4	17.2	1.00	6.6	10.8	28.5
CTB-17	2500	10.8	27.000	15.2	18.5	0.85	7.3	12.5	32.0
CTB-19	1800	20.3	36.540	17.8	20.0	1.30	10.4	12.0	35.0
CTB-20	1700	21.4	36.380	18.4	21.6	1.30	9.1	12.1	32.0
CTB-22	1500	23.2	34.755	20.5	24.5	1.30	8.5	12.5	36.0
CTB-23	1000	27.5	27.500	21.0	24.7	1.50	8.1	12.9	39.0
CTB-24	1250	24.0	29.975	22.0	26.0	1.30	8.1	12.7	36.0
CTB-25	1000	29.5	29.500	23.5	26.8	1.50	9.3	12.4	34.0
CTB-26	1000	31.9	31.900	24.3	28.0	1.60	10.0	12.6	34.0
CTB-27	1000	33.6	33.570	25.2	28.9	1.60	10.1	12.5	38.0
CTB-29	900	38.9	35.010	27.0	31.5	1.73	10.3	13.3	35.0
CTB-30	900	38.2	34.380	28.0	32.5	1.73	11.4	13.4	41.0
CTB-32	700	38.9	27.230	29.3	34.5	1.73	11.7	12.1	44.0
CTB-35	700	44.2	30.940	31.5	38.0	1.73	11.1	15.0	50.0
CTB-36	700	44.4	31.080	32.5	39.0	1.73	11.3	13.3	48.0
CTB-38	600	47.5	28.500	34.5	41.5	1.73	10.2	15.1	52.0
CTB-40	600	47.9	28.740	35.5	42.5	1.73	11.1	13.0	52.0
CTB-42	500	54.0	27.000	37.2	44.5	1.90	10.6	14.7	52.0
CTB-44	500	56.1	28.050	38.5	46.5	1.90	11.0	14.5	53.0
CTB-46	500	61.4	30.675	40.5	48.5	2.00	11.5	14.4	55.0
CTB-47	450	63.5	28.575	41.4	50.0	2.00	13.2	14.3	59.0
CTB-50	450	67.1	30.195	43.5	53.0	2.00	11.3	14.4	59.0
CTB-51	350	67.4	23.590	44.0	54.0	2.00	11.2	15.6	60.0
CTB-53	300	77.8	23.340	46.0	55.8	2.20	11.1	16.5	61.0
CTB-55	250	79.0	19.750	46.8	58.0	2.20	11.3	15.2	65.0
CTB-58	250	85.1	21.275	50.0	61.0	2.25	10.5	14.8	66.0
CTB-61	200	98.9	19.780	54.0	65.0	2.40	12.2	15.0	69.0
CTB-67	175	108.5	18.988	60.0	72.0	2.40	13.1	16.0	78.0

\* A Magni 511 finish offers 480 hours salt spray protection per ASTM B117. Is is a chrome-free duplex coating system that combines an inorganic zinc-rich basecoat with an organic topcoat.

Magni 511 meets the following automotive specifications: General Motors: GM7111M, GMW14100; Chrysler: PS-7626;

Ford: S441 (WSS-M21P37-A2); Delphi: DX550041.

Mechanical Zinc is also available along with other finishes. Inquire for more information.



## CTN - Constant Tension Band Narrow, Self-Compensating Hose Clamp

CTN's are available in a width of 12mm, and are typically used in places where a standard width CTB band clamp (15mm) is too wide for the application. CTN clamps are suited for applications that would normally require a CTB clamp. Nominal diameters range from 13mm to 90mm. Contact tech@rotorclip.com for more specifications.

# Constant Tension Light Band, Self-Compensating Hose Clamp

These are cost effective alternatives to other types of band clamps, but do not compromise quality or reliability.

# CTL Hose Clamps

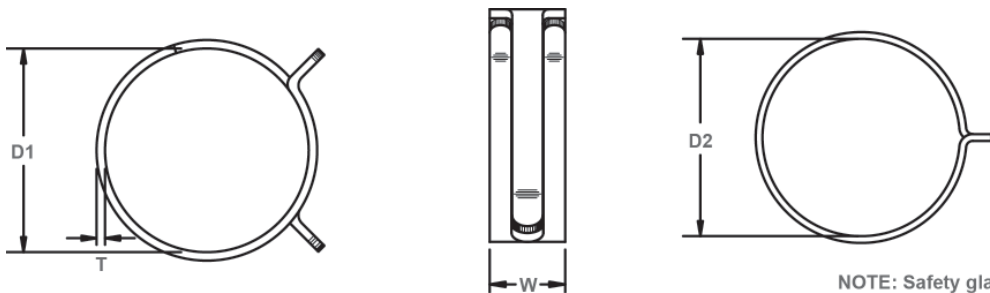

NOTE: Safety glasses should be worn when installing parts.

**FINISH:** Phosphate; Mechanical Zinc Plate

**MATERIAL:** SAE 1060-1090 Spring Steel, Austempered

ROTOR CLAMP CTL NO.	NOM. HOSE O.D.		FREE I.D. MAX D1		FULL OPEN DIAMETER MIN D2		W (Ref)		THICKNESS T	
	Inch	mm	Inch	mm	Inch	mm	Inch	mm	Inch	mm
CTL-4	.23	5.9	.210	5.33	.250	6.35	.25	6.3	.020	0.51
CTL-4.5	.28	7.1	.240	6.10	.300	7.62	.25	6.3	.015	0.38
CTL-4.5 SP1	.28	7.1	.240	6.10	.300	7.62	.25	6.3	.020	0.51
CTL-5	.31	7.9	.301	7.65	.345	8.76	.31	7.9	.030	0.76
CTL-6	.38	9.5	.321	8.15	.405	10.29	.31	7.9	.020	0.51
CTL-6 SP1	.38	9.5	.335	8.51	.410	10.41	.31	7.9	.020	0.51
CTL-6.5	.41	10.3	.375	9.53	.450	11.43	.31	7.9	.025	0.64
CTL-7	.44	11.1	.405	10.29	.485	12.32	.31	7.9	.025	0.64
CTL-7.5	.47	11.9	.430	10.92	.515	13.08	.31	7.9	.025	0.64
CTL-8	.50	12.7	.460	11.68	.545	13.84	.31	7.9	.030	0.76
CTL-8.5	.53	13.5	.490	12.45	.573	14.55	.31	7.9	.030	0.76
CTL-9	.56	14.3	.500	12.70	.621	15.77	.31	7.9	.030	0.76
CTL-9 SP1	.56	14.3	.520	13.21	.605	15.37	.31	7.9	.030	0.76
CTL-9.5	.59	15.1	.540	13.72	.650	16.51	.31	7.9	.030	0.76
CTL-10	.63	15.9	.583	14.81	.668	16.97	.31	7.9	.030	0.76
CTL-10.5	.66	16.7	.620	15.75	.725	18.42	.31	7.9	.030	0.76
CTL-11	.69	17.5	.583	14.81	.720	18.29	.31	7.9	.030	0.76
CTL-11 SP1	.69	17.5	.639	16.23	.709	18.01	.31	7.9	.045	1.14
CTL-11 SP2	.69	17.5	.655	16.64	.750	19.05	.31	7.9	.030	0.76
CTL-11.5	.72	18.3	.685	17.40	.775	19.69	.38	9.5	.050	1.27
CTL-12	.75	19.1	.645	16.38	.828	21.03	.38	9.5	.030	0.76
CTL-13	.81	20.6	.750	19.05	.900	22.86	.38	9.5	.040	1.02
CTL-14	.88	22.2	.810	20.58	.970	24.64	.38	9.5	.040	1.02
CTL-15	.94	23.8	.860	21.84	1.030	26.16	.38	9.5	.045	1.14
CTL-16	1.00	25.4	.910	23.11	1.080	27.43	.38	9.5	.045	1.14
CTL-16.5	1.03	26.2	.950	24.13	1.130	28.70	.38	9.5	.035	0.89
CTL-17	1.06	27.0	.970	24.64	1.180	29.97	.38	9.5	.045	1.14
CTL-18	1.13	28.6	1.040	26.42	1.240	31.50	.38	9.5	.045	1.14
CTL-19	1.19	30.2	1.100	27.94	1.280	32.51	.38	9.5	.045	1.14
CTL-20	1.25	31.8	1.180	29.97	1.450	36.83	.38	9.5	.045	1.14
CTL-24	1.50	38.1	1.350	34.29	1.670	42.42	.38	9.5	.045	1.14
CTL-26	1.63	41.3	1.450	36.83	1.800	45.72	.38	9.5	.045	1.14



# Standard Pliers

## Standard Retaining Ring Pliers - Inch & Metric

Rotor Clip Standard Retaining Ring Pliers are made of high carbon, heat treated steel and produced to exacting QC specifications. They feature stop and return springs for problem-free installation/removal of retaining rings. This eliminates overspreading of external retaining rings, and speeds the assembly/removal of internal retaining rings by orienting plier to exact location of lug holes. Most Rotor Clip retaining ring pliers have exclusive air-cushioned handles.



Inch Plier Dimensions

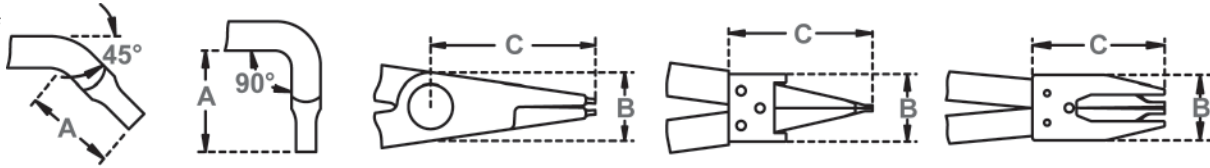

### Internal Inch

For use with the following inch retaining rings:

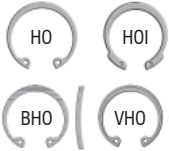

INTERNAL STANDARD PLIERS								GENERAL DIMENSIONS (inches)						
Ring Series/Size Range				ROTOR CLIP PLIERS	45° TIP PLIERS	90° TIP PLIERS	Weight lbs.	Tip Dia.	Tip Length A	CLOSED POSITION				
HO-BHO-VHO		HOI								Clearance		Length Std. Tip	Width	
FROM	THRU	FROM	THRU	B	C									
-25	-31	-62	-	RPS-100	RPS-104	RPS-109	.15	.025	9/32	7/8	1-7/8	5-1/2	1-7/8	
-37	-56	-75	-100	RP-100	RP-104	RP-109	.15	.038	9/32	7/8	1-7/8	5-1/2	1-7/8	
-62	-102	-106	-137	RPL-100	RPL-104	RPL-109	.15	.047	9/32	7/8	1-7/8	5-1/2	1-7/8	
-106	-175	-143	-200	RP-300	RP-304	RP-309	.17	.070	11/32	7/8	2-1/8	6-7/16	2-1/4	
-181	-300	-206	-300	RP-500	RP-504	RP-509	.62	.090	7/16	1-1/8	2-3/4	9	2-1/4	

### External Inch

For use with the following inch retaining rings:



EXTERNAL STANDARD PLIERS								GENERAL DIMENSIONS (inches)									
Ring Series/Size Range				ROTOR CLIP PLIERS	45° TIP PLIERS	90° TIP PLIERS	Weight lbs.	Tip Dia.	Tip Length A	CLOSED POSITION							
SH-BSH-VSH		SHI								SHR		SHF		Clearance		Length Std. Tip	Width
FROM	THRU	FROM	THRU	FROM	THRU	FROM	THRU	B	C								
-12	-	-	-	-	-	-	-	RP-12	RP-2124	RP-2129	.05	.023	7/32	1/2	1-1/8	5-5/16	1-1/2
-15	-	-	-	-	-	-	-	RP-15	RP-2154	RP-2159	.05	.023	7/32	1/2	1-1/8	5-5/17	1-1/2
-18	-23	-	-	-	-	-	-	RP-18	RP-2184	RP-2189	.05	.023	7/32	1/2	1-1/8	5-5/18	1-1/2
-25	-66	-50	-78	-39	-47	-	-	RP-200	RP-204	RP-209	.15	.038	9/32	1	2	5-1/2	2-1/2
-68	-87	-81	-100	-50	-66	-	-	RPL-200	RPL-204	RPL-209	.15	.047	9/32	1	2	5-1/2	2-1/2
-93	-143	-106	-200	-	-	-	-	RP-400	RP-404	RP-409	.19	.070	11/32	1	2-3/8	7	2-7/8
-150	-350	-215	-325	-	-	-	-	RP-600	RP-604	RP-609	.44	.115	7/16	1-1/4	3-1/16	9-1/8	4-1/4
-	-	-	-	-75	-98	-31	-75	RPA-2	RPA-245	RPA-290	.22	.070	9/16	1	2	7-1/4	2-1/2

External pliers RP-12, RP-15 & RP-18 are available in the standard version with shielded tips. The 45° and 90° versions are unshielded. Both are equipped with fixed stops to prevent overspreading of the external retaining rings during installation or removal.

Metric Plier Dimensions

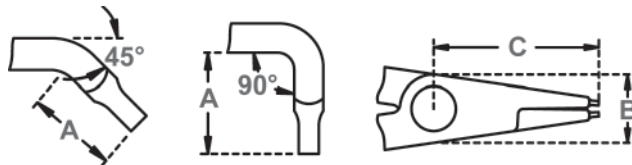

Please wear protective eyewear while installing and removing retaining rings & hose clamps.

### Internal Metric

For use with the following metric retaining rings:



METRIC INTERNAL PLIERS (All Dimensions in mm)						FULLY COMPRESSED (TIPS BUTTING) CONDITION					
Ring Series/Size Range		ROTOR CLIP PLIERS	45° TIP PLIERS	90° TIP PLIERS	Weight Kg	Tip Dia.	Tip Length A	Tip Clearance		Overall Length Straight Tip	Max Width Across Handle
DHO (DIN 472), DHT (DIN 984)								B	C		
FROM	THRU										
-8	-13	RPN-J0*	-	RPN-J01*	-	0.9	-	-	-	-	-
-12	-25	RPN-J1*	-	RPN-J11*	-	1.2	-	-	-	-	-
-18	-30	RPI-2	RPI-245	RPI-290	0.1	1.8	10	25	55	165	60
-31	-83	RPI-3	RPI-345	RPI-390	0.23	2.3	14	30	70	230	65
-85	-100	RPI-4	RPI-445	RPI-490	0.42	3.2	20	45	70	300	55

\*See page 244 : Heavy Duty Retaining Ring Pliers.

### External Metric

For use with the following metric retaining rings:



METRIC EXTERNAL PLIERS (All Dimensions in mm)						FREE (UNEXPANDED) CONDITION					
Ring Series/Size Range		ROTOR CLIP PLIERS	45° TIP PLIERS	90° TIP PLIERS	Weight Kg	Tip Dia.	Tip Length A	Tip Clearance		Overall Length Straight Tip	Max Width Across Handle
DSH (DIN 471), DST (DIN 983)								B	C		
FROM	THRU										
-3	-9	RPA-0	RPA-045	RPA-090	0.07	0.9	8	22	38	140	75
-10	-17	RPA-1	RPA-145	RPA-190	0.07	1.3	8	22	38	140	75
-18	-30	RPA-2	RPA-245	RPA-290	0.1	1.8	14	25	50	185	100
-19	-60	RPN-A2*	-	RPN-A21*	-	1.8	-	-	-	-	-
-40	-82	RPN-A3*	-	RPN-A31*	-	2.3	-	-	-	-	-
-85	-100	RPA-4	RPA-445	RPA-490	0.46	3.2	20	45	80	300	175

\*See page 244 : Heavy Duty Retaining Ring Pliers.

# Ratchet & Grip Ring Pliers



## Ratchet Retaining Ring Pliers

Assemble large retaining rings up to 10" in diameter with ease and comfort using Rotor Clip Ratchet Pliers. Spring loaded mechanisms compress or expand large rings through gradual "steps." Plier locks at the desired size without continued pressure on the handles.

(Note: Ratchet Pliers do not include plier tips, which must be purchased separately.)

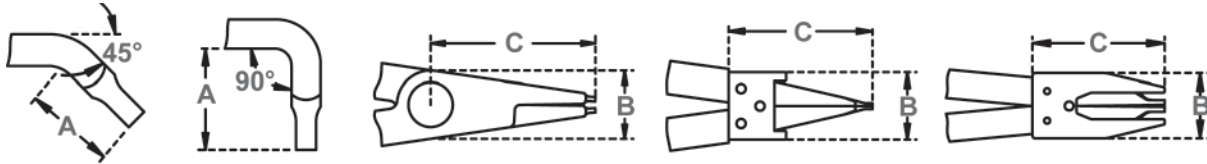

RATCHET PLIERS INTERNAL**										GENERAL DIMENSIONS (inches)					
Ring Series/Size Range				PLIERS W/OUT TIPS	STD. TIPS	45° TIPS	90° TIPS	TIP COLOR CODE	Weight lbs.	Tip Dia.	Tip Length A	CLOSED POSITION			
HO-BHO-VHO	HOI											Clearance	Length Std. Tip		Width
FROM	THRU	FROM	THRU								B	C			
-181	-237	-206	-250	RP-27R	RP-5021R	RP-5023R	RP-5024R	GOLD	.70	.093	15/32	1-3/8	3-13/32	10-5/8	3
-244	-300	-262	-300	RP-27R	RP-5005R	RP-5007R	RP-5008R	BLACK	.70	.108	15/32	1-3/8	3-13/32	10-5/8	3
-306	-400	-315	-400	RP-27R	RP-5009R	RP-5012R	RP-5013R	SILVER	.70	.120	15/32	1-3/8	3-13/32	10-5/8	3
-306	-600	-315	-400	RP-900	RP-7801R	RP-7845R	RP-7890R	BLACK	1.9	.120	1/2	1-3/4	3-1/2	16	3-7/8
-625	-1000	-	-	RP-1100	RP-71001R	RP-71451R	RP-71901R	BLACK	5.0	.150	1-5/32	1-3/4	4-5/16	28	6-1/2

\*\*PLIERS AND PLIER TIPS MUST BE ORDERED TOGETHER TO BE USABLE. TIPS ARE INTERCHANGEABLE FOR INTERNAL AND EXTERNAL USE.

### Internal

For use with the following retaining rings:

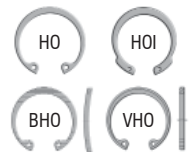

RATCHET PLIERS EXTERNAL**										GENERAL DIMENSIONS (inches)							
Ring Series/Size Range				PLIERS W/OUT TIPS	STD. TIPS	45° TIPS	90° TIPS	TIP COLOR CODE	Weight lbs.	Tip Dia.	Tip Length A	CLOSED POSITION					
SH-BSH-VSH	SHI											SHR	Clearance	Length Std. Tip		Width	
FROM	THRU	FROM	THRU	FROM	THRU						B	C					
-	-	-	-	-106	-137	RP-28R	RP-5021R	RP-5023R	RP-5024R	GOLD	.70	.093	15/32	1-3/8	3-3/8	10-5/8	4-11/32
-150	-375	-215	-325	-	-	RP-28R	RP-5009R	RP-5012R	RP-5013R	SILVER	.70	.120	15/32	1-3/8	3-3/8	10-5/8	4-11/32
-	-	-	-	-150	-175	RP-1000	RP-8002R	RP-8452R	RP-8902R	BLACK	1.9	.108	5/8	2-1/2	3-5/8	14-1/2	13
-354	-650	-350	-393	-193	-200	RP-1000	RP-7801R	RP-7845R	RP-7890R	BLACK	1.9	.120	5/8	2-1/2	3-5/8	14-1/2	13
-675	-950	-	-	-	-	RP-1200	RP-68001R	RP-68451R	RP-68901R	BLACK	2.2	.170	1-5/32	2-1/2	4-7/8	18-1/4	14

\*\*PLIERS AND PLIER TIPS MUST BE ORDERED TOGETHER TO BE USABLE. TIPS ARE INTERCHANGEABLE FOR INTERNAL AND EXTERNAL USE.

### External

For use with the following retaining rings:



## Grip Ring Retaining Ring Pliers

Rotor Clip Grip Ring Pliers are designed for SHF & DSF external (shaft) friction rings. The pliers are made of forged Chrome Vanadium steel with non-slip solid tips, and the handles have a non-slip plastic coating.

Please wear protective eyewear while installing and removing retaining rings & hose clamps.

HEAVY DUTY PLIERS - EXTERNAL (Inch & Metric)				
Ring Series/Size Range				ROTOR CLIP PLIERS
SHF (in.)		DSF (mm)		
FROM	THRU	FROM	THRU	
-6	-12	-1.5	-4	RPN-G0
-15	-15	-4	-7	RPN-G1
-18	-25	-5	-13	RPN-G2
-31	-75	-14	-18	RPN-G3

### External

For use with the following retaining rings:





# Convertible & Heavy-Duty Pliers

## Convertible Retaining Ring Pliers

Convert quickly and easily from internal to external pliers and back again. This two-in-one capability is cost effective and ideal for handling a variety of applications with a minimum number of tools. Simply move the screw to the other hole and tighten with finger pressure to convert quickly to an internal/external plier.

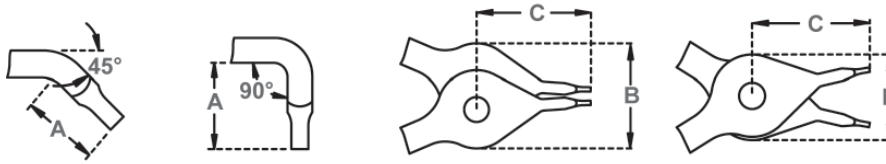

Please wear protective eyewear while installing and removing retaining rings & hose clamps.

### Internal

For use with the following retaining rings:

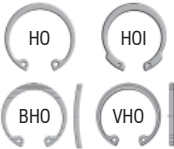

CONVERTIBLE PLIERS, INTERNAL RING SERIES									GENERAL DIMENSIONS (inches)					
Ring Series/Size Range				ROTOR CLIP PLIERS	45° TIP PLIERS	90° TIP PLIERS	Weight lbs.	Tip Dia.	Tip Length A	CLOSED POSITION			Length Std. Tip	Width
HO-BHO-VHO		HOI								Clearance				
FROM	THRU	FROM	THRU						B	C				
-37	-43	-75	-100	RP-120	RP-124	RP-129	.19	.038	9/32	1-3/16	1-5/8	5-5/8	1-3/4	
-45	-102	-106	-137	RP-320	RP-324	RP-329	.19	.047	9/32	1-3/16	1-5/8	5-5/8	1-3/4	
-106	-175	-143	-200	RP-340	RP-344	RP-349	.45	.070	11/32	1-7/16	1-7/8	7-7/8	3-5/16	
-181	-206	-206	-212	RP-560	RP-564	RP-569	.55	.090	5/8	1-3/4	3	9-1/4	4-1/2	

### External

For use with the following retaining rings:



CONVERTIBLE PLIERS, EXTERNAL RING SERIES									GENERAL DIMENSIONS (inches)								
Ring Series/Size Range				ROTOR CLIP PLIERS	45° TIP PLIERS	90° TIP PLIERS	Weight lbs.	Tip Dia.	Tip Length A	CLOSED POSITION			Length	Width			
SH-BSH-VSH		SHI								SHR		SHF			Clearance		
FROM	THRU	FROM	THRU	FROM	THRU	FROM	THRU		B	C							
-25	-60	-50	-78	-39	-47	-12	-25	RP-120	RP-124	RP-129	.19	.038	9/32	1-3/8	1-5/8	5-5/8	2-9/16
-68	-87	-81	-100	-50	-66	-31	-37	RP-320	RP-324	RP-329	.19	.047	9/32	1-3/8	1-5/8	5-5/8	2-9/16
-93	-143	-106	-200	-75	-98	-43	-75	RP-340	RP-344	RP-349	.45	.070	11/32	1-11/16	1-7/8	7-7/8	3-15/16
-150	-200	-	-	-	-	-	-	RP-560	RP-564	RP-569	.55	.090	5/8	1-7/8	3	9-1/4	4-1/2

## Heavy-Duty Retaining Ring Pliers

Rotor Clip Heavy-Duty Retaining Ring Pliers are designed to perform with excessive use - up to 10 times longer than standard retaining ring pliers. The pliers are made of forged Chrome Vanadium steel, and the handles have a non-slip plastic coating. They feature inserted tips of high density drawn spring wire and a precise, smooth operating screw joint. Large contact faces on the tips helps to eliminate distortion of the ring, and the slim head style allows for use in confined areas.



### Internal

For use with the following retaining rings:



HEAVY DUTY PLIERS - INTERNAL (Inch & Metric)											ROTOR CLIP PLIERS	90° CLIP PLIERS	TIP DIAMETER
Ring Series/Size Range													
HO		HOI		DHO (DIN 472)		DHT (DIN 984)		MHO (ANSI Metric)					
(in.)		(in.)		(mm)		(mm)		(mm)				(mm)	
FROM	THRU	FROM	THRU	FROM	THRU	FROM	THRU	FROM	THRU				
-37	-56	-75	-100	-8	-13	-	-	-8	-15	RPN-J0	RPN-J01	0.9	
-62	-102	-106	-137	-12	-25	-16	-25	-15	-26	RPN-J1	RPN-J11	1.2	
-106	-175	-143	-200	-19	-60	-19	-60	-27	-60	RPN-J2	RPN-J21	1.8	
-181	-300	-206	-300	-40	-100	-40	-100	-62	-100	RPN-J3	RPN-J31	2.3	

### External

For use with the following retaining rings:

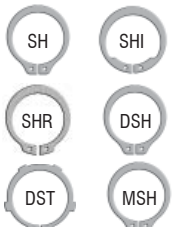

HEAVY DUTY PLIERS - EXTERNAL (Inch & Metric)											ROTOR CLIP PLIERS	90° CLIP PLIERS	TIP DIAMETER
Ring Series/Size Range													
SH		SHI		SHR		DSH (DIN 471)		MSH (ANSI Metric)					
(in.)		(in.)		(in.)		(mm)		(mm)				(mm)	
FROM	THRU	FROM	THRU	FROM	THRU	FROM	THRU	FROM	THRU				
-25	-66	-50	-78	-39	-47	-3	-10	-4	-12	RPN-A0	RPN-A01	0.9	
-68	-87	-81	-100	-50	-66	-10	-25	-13	-23	RPN-A1	RPN-A11	1.2	
-93	-143	-106	-220	-75	-98	-19	-60	-24	-36	RPN-A2	RPN-A21	1.8	
-150	-350	-215	-350	-	-	-40	-100	-38	-90	RPN-A3	RPN-A31	2.3	

# Applicators & Dispensers

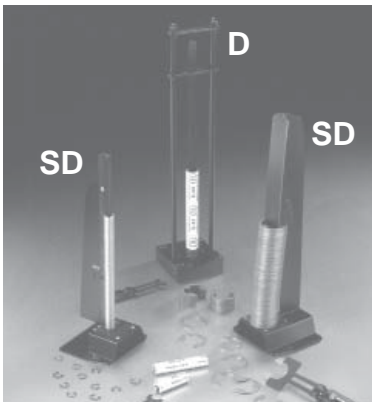

**Retaining Ring Dispensers** Rotor Clip retaining ring dispensers feature “rail” over which a stack of retaining rings can be slipped. Once in position, they can be “dispensed” one at a time using a retaining ring applicator for ease of installation. Two such models are available to meet your particular dispensing needs: **Spring Rail (SD)** dispensers are competitively priced and offer significant improvements (like more rail capacity and durable construction) on existing designs.

**The Heavy Duty (D)** is a more permanent version which features replaceable parts and can be permanently affixed to your work station. For use with Rotor Clip **C, E/SE/YE, RE, PO/POL, DE, DC, ME & JE** rings.

**Features:**

- Sturdy, Industrial-Quality Construction.
- Fast, Easy Loading.
- Accept Tape-Stacked Rings.
- Precise, Single Ring Ejection.
- Longer Rail For More Capacity.
- Part and Tool Number Stamped on Dispenser for Fast, Easy Identification of Tool and Corresponding Ring.
- Powder Metal Coating for a Durable, No-Rust Finish (Spring Rail Dispenser, Only.)

## Retaining Ring Applicators

Applicators are designed to install standard inch & metric radial retaining rings on a shaft. Used with Rotor Clip Dispensers, applicators enable operators to install rings quickly and correctly and allows for installation without turning the tool (ring “snaps” when properly seated in groove.) Heat treated for strength. For use with Rotor Clip **C, E/SE/YE, BE, RE, PO/POL, EL, DE, DC, ME and JE** Retaining rings.

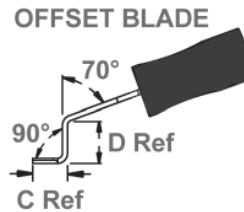
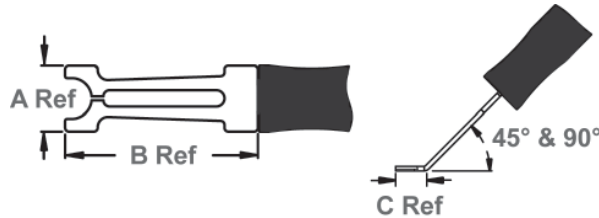

*Please wear protective eyewear while installing and removing retaining rings & hose clamps.*

### E Applicators & Dispensers

For use with Rotor Clip “E/SE/YE” Rings.\*

### C Applicators & Dispensers

For use with Rotor Clip “C” Rings.\*

RING SIZE	APPLICATORS					DISPENSERS	
	APP. NO.	BLADE WIDTH A	BLADE LENGTH B	TIP LENGTH C	OFFSET D	HEAVY DUTY DISP. NO.	SPRING RAIL DISP. NO.
E-4	A-010	.265	1.438	.375	.250	-	-
E-6	A-040	.265	1.438	.375	.375	D-210	SD-210
SE-6	A-020	.265	1.438	.375	.375	D-390	SD-390
YE-6	A-030	.500	1.438	.375	.375	D-460	SD-460
SE-9	A-050	.500	1.438	.375	.375	D-330	SD-395
E-9	A-510	.500	1.438	.375	.375	D-220	SD-220
SE-11	A-060	.500	1.438	.375	.375	D-400	SD-400
SE-12	A-N50	.500	1.438	.375	.375	D-231	-
E-12	A-050	.500	1.438	.375	.375	D-230	SD-230
SE-14	A-080	.500	1.438	.375	.375	D-230	SD-405
YE-14	A-090	.500	1.438	.375	.375	D-465	SD-465
E-14	A-070	.500	1.438	.375	.375	D-240	SD-240
E-15	A-100	.500	1.438	.375	.375	D-250	SD-250
SE-17	A-110	.500	1.438	.375	.375	D-410	SD-410
SE-18	A-130	.500	1.438	.375	.375	D-350	SD-415
E-18	A-120	.500	1.438	.375	.375	D-260	SD-260
SE-21	A-140	.812	2.218	.593	.625	D-360	SD-416
E-25	A-150	.812	2.218	.593	.625	D-270	SD-270
SE-31	A-160	.812	2.218	.593	.625	D-420	SD-420
SE-37	A-290	.812	2.218	.593	.625	D-608	-
E-37	A-170	.812	2.218	.593	.625	D-280	SD-280
E-43	A-180	.812	2.218	.593	.625	D-290	SD-290
SE-43	A-190	.812	2.218	.593	.625	D-430	SD-430
E-50	A-200	1.125	2.390	.765	.625	D-300	SD-300
E-62	A-210	1.125	2.390	.765	.625	D-160	SD-305
SE-74	A-220	1.562	2.625	.969	.625	D-440	SD-440
E-75	A-230	1.562	2.625	.969	.625	D-310	SD-310
E-87	A-240	1.562	2.625	.969	.625	D-320	SD-320
SE-98	A-250	1.875	2.844	1.188	.625	D-450	SD-450
SE-118	A-260	1.875	2.844	1.188	.625	-	-
SE-137	A-491	2.250	3.344	N/A	N/A	-	-

RING SIZE	APPLICATORS					DISPENSERS	
	APP. NO.	BLADE WIDTH A	BLADE LENGTH B	TIP LENGTH C	OFFSET D	HEAVY DUTY DISP. NO.	SPRING RAIL DISP. NO.
C-12	A-300	.264	1.438	.375	.375	D-10	SD-10
C-15	A-080	.500	1.438	.375	.375	D-20	SD-20
C-18	A-090	.500	1.438	.375	.375	D-30	SD-30
C-21	A-310	.350	1.438	.375	.375	D-40	SD-40
C-23	A-320	.500	1.438	.375	.375	D-50	SD-50
C-25	A-330	.500	1.438	.375	.375	D-60	SD-60
C-28	A-340	.500	1.438	.375	.375	D-70	SD-70
C-31	A-350	.500	1.438	.375	.375	D-80	SD-80
C-37	A-360	.812	2.218	.593	.625	D-90	SD-90
C-40	A-370	.812	2.218	.593	.625	D-100	SD-100
C-43	A-380	.812	2.218	.593	.625	D-110	SD-110
C-50	A-290	.812	2.218	.593	.625	D-120	SD-120
C-56	A-390	.812	2.218	.593	.625	D-130	SD-130
C-62	A-400	1.125	2.390	.765	.625	D-140	SD-140
C-68	A-410	1.125	2.390	.765	.625	D-150	SD-150
C-75	A-280	1.125	2.390	.765	.625	D-160	SD-160
C-81	A-420	1.125	2.390	.765	.625	D-170	SD-170
C-87	A-430	1.125	2.390	.765	.625	D-180	SD-180
C-93	A-440	1.562	2.625	.969	.625	-	-
C-100	A-450	1.562	2.625	.969	.625	D-190	SD-190
C-112	A-460	1.562	2.625	.969	.625	D-200	SD-200
C-125	A-470	1.562	2.625	.969	.625	-	-
C-137	A-480	1.562	1.875	1.188	.625	-	-
C-150	A-490	1.562	1.875	1.188	.625	-	-
C-162	A-491	2.250	3.344	N/A	N/A	-	-
C-175	A-492	2.250	3.344	N/A	N/A	-	-

\*45°, 90° and Offset applicators for C, E and RE retaining rings - Replace the last “0” of the applicator designation with a “4” (45°), “9” (90°), or “7” (Offset). (Ex., A-304, A-309, A-307, etc.)



# Applicators & Dispensers



## Applicators & Dispensers

For use with Rotor Clip "PO/POL" Rings.\*\*

RING SIZE	APPLICATORS					DISPENSERS	
	APP. NO.	BLADE WIDTH	BLADE LENGTH	TIP LENGTH	OFFSET	HEAVY DUTY DISP. NO.	SPRING RAIL DISP. NO.
PO-15	A-815	.500	1.438	.375	.625	D-800	SD-800
PO-18	A-818	.812	2.218	.593	.625	D-810	SD-810
PO-25	A-825	.812	2.218	.593	.625	D-820	SD-820
PO-31	A-831	.812	2.218	.593	.625	D-830	SD-830
PO-37	A-837	1.125	2.390	.765	.625	D-840	SD-840
PO-43	A-843	1.125	2.390	.765	.625	D-850	SD-850
PO-50	A-850	1.125	2.390	.765	.625	D-860	SD-860
PO-62	A-862	1.125	2.393	0.562	N/A	-	-
PO-75	A-875	1.562	2.625	0.812	N/A	-	-
PO-100	A-810	1.875	2.844	1.000	N/A	-	-
POL-15	A-915	.500	1.438	.375	.625	D-900	SD-900
POL-18	A-918	.812	2.218	.593	.625	D-910	SD-910
POL-25	A-925	.812	2.218	.593	.625	D-920	SD-920
POL-31	A-931	.812	2.218	.593	.625	D-930	SD-930
POL-37	A-937	1.125	2.390	.765	.625	D-940	SD-940
POL-43	A-943	1.125	2.390	.765	.625	D-950	SD-950
POL-50	A-950	1.125	2.390	.765	.625	D-960	SD-960
POL-62	A-962	1.125	2.393	0.562	N/A	-	-
POL-75	A-975	1.562	2.625	0.812	N/A	-	-
POL-100	A-910	1.875	2.844	1.000	N/A	-	-

Applicators for PO/POL -62 thru -100 are sold as follows:



### Heavy Duty Applicator Handles

Install large PO/POL retaining rings (sizes -62 to -100) quickly and safely. Features an applicator blade affixed to a heavy-duty handle. Plastic grip enables

you to hold tool steady as you strike the rear of the tool with a hammer/mallet to install the ring. Shield at top prevents injury.



## Applicators & Dispensers

For use with Rotor Clip "DC" Rings.\*\*

RING SIZE	APPLICATORS	DISPENSERS	RING SIZE	APPLICATORS
	APP. NO.	HEAVY DUTY DISP. NO.		APP. NO.
DC-3	A-545	-	DC-22	A-583
DC-4	A-080	D-502	DC-23	A-584
DC-5	A-547	D-503	DC-24	A-585
DC-6	A-320	-	DC-25	A-586
DC-7	A-120	D-757	DC-26	A-586
DC-8	A-570	D-506	DC-28	A-588
DC-9	A-571	D-507	DC-30	A-589
DC-10	A-572	D-508	DC-32	A-590
DC-11	A-573	D-608	DC-35	A-591
DC-12	A-290	D-515	DC-36	A-592
DC-13	A-190	-	DC-38	A-593
DC-14	A-390	-	DC-40	A-594
DC-15	A-577	-	DC-42	A-595
DC-16	A-400	-	DC-45	A-596
DC-17	A-579	-	DC-48	A-597
DC-18	A-200	-	DC-50	A-598
DC-19	A-280	-	DC-52	A-599
DC-20	A-582	-	DC-55	A-600

Please contact Technical Sales for DC applicator specifications: +1 732.469.7333, tech@rotorclip.com.



## Applicators & Dispensers

For use with Rotor Clip "RE" Rings.\*

RING SIZE	APPLICATORS					DISPENSERS	
	APP. NO.	BLADE WIDTH	BLADE LENGTH	TIP LENGTH	OFFSET	HEAVY DUTY DISP. NO.	SPRING RAIL DISP. NO.
RE-9	A-080	.500	1.438	.375	.375	D-330	SD-330
RE-12	A-520	.500	1.438	.375	.375	D-340	SD-340
RE-15	A-120	.500	1.438	.375	.375	D-350	SD-350
RE-18	A-130	.500	1.438	.375	.375	D-260	SD-355
RE-21	A-140	.812	2.218	.593	.625	D-360	SD-360
RE-25	A-160	.812	2.218	.593	.625	D-270	SD-365
RE-31	A-500	.812	2.218	.593	.625	D-370	SD-370
RE-37	A-170	.812	2.218	.593	.625	D-280	SD-375
RE-43	A-270	1.125	2.390	.765	.625	D-380	SD-380
RE-50	A-200	1.125	2.390	.765	.625	D-300	SD-385
RE-56	A-280	1.125	2.390	.765	.625	D-150	SD-386



## Applicators & Dispensers

For use with Rotor Clip "ME" Rings.\*\*

RING SIZE	APPLICATORS					DISPENSERS
	APP. NO.	BLADE WIDTH	BLADE LENGTH	TIP LENGTH	OFFSET	HEAVY DUTY DISP. NO.
ME-1	A-010	.265	1.438	.375	.375	-
ME-2	A-040	.265	1.438	.375	.375	D-210
ME-3	A-050	.500	1.438	.375	.375	D-230
ME-4	A-100	.500	1.438	.375	.375	D-250
ME-5	A-120	.500	1.438	.375	.375	D-260
ME-6	A-140	.812	2.218	.593	.625	D-360
ME-7	A-150	.812	2.218	.593	.625	D-270
ME-8	A-290	.812	2.218	.593	.625	D-370
ME-9	A-608	.812	2.218	.593	.625	D-690
ME-10	A-170	.812	2.218	.593	.625	D-280
ME-11	A-180	.812	2.218	.593	.625	D-290
ME-12	A-609	1.125	2.390	.765	.625	D-660
ME-13	A-200	1.125	2.390	.765	.625	D-300
ME-15	A-612	1.125	2.390	.969	.625	D-672
ME-16	A-210	1.125	2.390	.765	.625	D-160
ME-22	A-240	1.125	2.625	.969	.625	D-320



## Applicators & Dispensers

For use with Rotor Clip "JE" Rings.\*\*

RING SIZE	APPLICATORS					DISPENSERS
	APP. NO.	BLADE WIDTH	BLADE LENGTH	TIP LENGTH	OFFSET	HEAVY DUTY DISP. NO.
JE-2	A-080	.500	1.438	.375	.375	-
JE-2.5	A-050	.500	1.438	.375	.375	D-330
JE-3	A-070	.500	1.438	.375	.375	D-240
JE-4	A-340	.500	1.438	.375	.375	D-757
JE-5	A-605	.812	2.218	.593	.625	D-758
JE-6	A-606	.812	2.218	.593	.625	D-759
JE-7	A-607	.812	2.218	.593	.625	-
JE-8	A-608	.812	2.218	.593	.625	D-761
JE-12	A-612	1.562	2.625	.969	.625	D-730

\*45°, 90° and Offset applicators for C, E and RE retaining rings - Replace the last "0" of the applicator designation with a "4" (45°), "9" (90°), or "7" (Offset.) (Ex., A-304, A-309, A-307, etc.)

\*\*45°, 90° and Offset applicators for DE, DC, PO/POL, EL, JE and ME retaining rings - To the end of the applicator designation, add a "4" (45°), "9" (90°), or "7" (Offset.) (Ex., A-7084, A-7089, A-7087, etc.)

Please wear protective eyewear while installing and removing retaining rings & hose clamps.





# Applicators & Dispensers

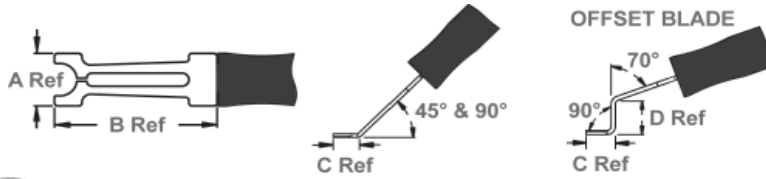

For Bowed "E" Rings



## DE Applicators & Dispensers

For use with Rotor Clip **ROD STACKED** "DE" Rings.\*\*

RING SIZE	APPLICATORS					ROD STACKED DISP. NO.
	APP. NO.	BLADE WIDTH A (mm)	BLADE LENGTH B (mm)	TIP LENGTH C (mm)	OFFSET D (mm)	
DE-0.8	A-708	6.73	36.53	9.53	9.53	-
DE-1.2	A-712N	5.59	36.53	9.53	9.53	RD-712
DE-1.5	A-715N	5.59	36.53	9.53	9.53	RD-715
DE-1.9	A-719N	5.59	36.53	9.53	9.53	RD-719
DE-2.3	A-723N	7.87	36.53	9.53	9.53	RD-723
DE-3.2	A-310N	8.89	36.53	9.53	9.53	RD-732
DE-4	A-340N	11.25	36.53	9.53	9.53	RD-410
DE-5	A-605N	13.06	56.34	15.06	15.88	RD-360
DE-6	A-606N	13.92	56.34	15.06	15.88	RD-360
DE-7	A-607N	17.22	56.34	15.06	15.88	RD-607
DE-8	A-608N	18.80	56.34	15.06	15.88	RD-608
DE-9	A-609N	21.50	60.71	19.43	15.88	RD-610
DE-10	A-610N	21.59	60.71	19.43	15.88	RD-610
DE-12	A-612	39.68	66.68	24.61	15.88	-
DE-15	A-615	39.67	66.68	24.61	15.88	-
DE-19	A-619	47.63	72.24	30.18	15.88	-

## Rod-Stacked Dispensers (RD)

Rotor Clip has developed a dispenser specifically for metric (DIN 6799) DE rings that are packaged stacked on rods (shown below.) The ends of the rod are secured to the back and top of the dispenser, and once in position, rings are dispensed one part at a time using an applicator. The compact design can be mounted on a work surface, and the corresponding ring number is stamped on the dispenser for easy identification.

Rod stacked rings and dispenser are purchased separately.



RD

## BE/BSE Applicator

For use with Rotor Clip "BE/BSE" Rings.

RING SIZE	APP. NO.	BLADE WIDTH A	BLADE LENGTH B	TIP LENGTH C	OFFSET D
BSE-11	A-550	.500	1.375	.375	.375
BE-12	A-551	.500	1.375	.375	.375
BE-14	A-552	.500	1.375	.375	.375
BSE-14	A-553	.500	1.375	.375	.375
BE-15	A-554	.500	1.375	.375	.375
BSE-17	A-555	.500	1.375	.375	.375
BE-18	A-556	.500	1.375	.375	.375
BSE-18	A-557	.500	1.375	.375	.375
BSE-21	A-558	.812	2.156	.625	.625
BE-25	A-559	.812	2.156	.625	.625
BSE-31	A-560	.812	2.156	.625	.625
BE-37	A-561	.812	2.156	.625	.625
BE-43	A-562	.812	2.156	.625	.625
BSE-43	A-563	.812	2.156	.625	.625
BE-50	A-564	1.125	2.250	.750	.875
BE-62	A-565	1.125	2.250	.750	1.000
BSE-74	A-566	1.562	2.469	1.093	1.000
BE-75	A-567	1.562	2.469	1.093	1.000
BE-87	A-568	1.562	2.469	1.093	1.000
BSE-98	A-569	1.875	2.812	1.188	1.188

For "EL" Retaining Rings with Grip (D)



## EL Applicator

For use with Rotor Clip "EL" Rings.\*\*

RING SIZE	APP. NO.	BLADE WIDTH A	BLADE LENGTH B	TIP LENGTH C	*** REPL. GRIPS
EL-9	A-091	.438	2.188	.375	A-091G
EL-12	A-112	.438	2.188	.375	A-112G
EL-18	A-118	.625	2.188	.563	A-118G
EL-25	A-125	.750	2.188	.625	A-125G
EL-31	A-131	1.000	2.625	.750	A-131G
EL-37	A-371	1.125	2.625	.813	A-371G
EL-43	A-143	1.125	2.625	.938	A-143G

\*\*\* An EL applicator consists of a tool and a grip. Replacement grips may be purchased without replacing the tool by using these order numbers.

## DE Applicators & Dispensers

For use with Rotor Clip **TAPE STACKED** "DE" Rings.\*\*  
Subject to availability.

RING SIZE	APPLICATORS					DISPENSERS	DISPENSERS
	APP. NO.	BLADE WIDTH A (mm)	BLADE LENGTH B (mm)	TIP LENGTH C (mm)	OFFSET D (mm)	HEAVY DUTY DISP. NO.	SPRING RAIL DISP. NO.
DE-0.8	A-708	6.73	36.53	9.53	9.53	-	-
DE-1.2	A-712	6.73	36.53	9.53	9.53	D-712	-
DE-1.5	A-715	6.73	36.53	9.53	9.53	D-715	SD-715
DE-1.9	A-719	6.73	36.53	9.53	9.53	D-715	SD-719
DE-2.3	A-723	12.70	36.53	9.53	9.53	D-723	SD-723
DE-3.2	A-310	8.89	36.53	9.53	9.53	D-732	SD-732
DE-4	A-340	12.70	36.53	9.53	9.53	D-410	SD-704
DE-5	A-605	20.62	56.34	15.06	15.88	D-360	SD-705
DE-6	A-606	20.62	56.34	15.06	15.88	D-360	SD-706
DE-7	A-607	20.62	56.34	15.06	15.88	D-607	SD-707
DE-8	A-608	20.62	56.34	15.06	15.88	D-608	SD-708
DE-9	A-609	28.58	60.71	19.43	15.88	D-610	SD-709
DE-10	A-610	28.58	60.71	19.43	15.88	D-610	SD-610
DE-12	A-612	39.67	66.68	24.61	15.88	D-612	SD-612
DE-15	A-615	39.67	66.68	24.61	15.88	-	-
DE-19	A-619	47.63	72.24	30.18	15.88	-	-

\*\*45°, 90° and Offset applicators for DE, DC, PO/POL, EL, JE and ME retaining rings - To the end of the applicator designation, add a "4" (45°), "9" (90°), or "7" (Offset). (Ex., A-7084, A-7089, A-7087, etc.)

Please wear protective eyewear while installing and removing retaining rings & hose clamps.



## TX Applicator - "Easy Guide"

Designed to comfortably fit in the palm of your hand, the lightweight TX Easy Guide allows you to painlessly install Rotor Clip's TX self-locking retaining rings. The nose is constructed from tool steel, a life extending material. Inside is a spring-loaded magnet. This magnet aggressively holds a retaining ring in place during installation. The spring, along

with the magnet, retracts into the handle while the tool forces the retaining ring over the shaft. Each ring is assigned its own Easy Guide, producing maximum tool performance.

RING SIZE	EASY-GUIDE TX TOOL #	FOR SHAFT DIA.
TX-9	RP-21104	3/32"
TX-12	RP-21105	1/8"
TX-15	RP-21106	5/32"
TX-18	RP-21107	3/16"
TX-25	RP-21108	1/4"
TX-31	RP-21109	5/16"
TX-37	RP-21110	3/8"
TX-43	RP-21111	7/16"
TX-50	RP-21112	1/2"

External  
For use with the following retaining ring:



Please contact Technical Sales for availability - tech@rotorclip.com



# Automatic Assembly Tools

## Rotor Kick Jr. (RKJ) Automated Assembly Retaining Ring Tool for RG-31 Rings

**External**  
For use with the following retaining ring:



**\*\*For RG-31 only\*\***

This ergonomic tool from Rotor Clip provides operator convenience and comfort along with efficient automated assembly. No electrical connections required. The tool is operated by air pressure for convenience and safety. And Carpal Tunnel Syndrome (CTS) injuries, caused by repetitive use of a manual tool, are eliminated. This hand-held tool is lightweight, portable and easy to use. A patented feeder mechanism, designed and built by Rotor Clip personnel, assures efficient, trouble-free operation.

Note: RG-31 rings must be purchased stacked for use the with Rotor Clip tool.



## XXL Retaining Ring Tool

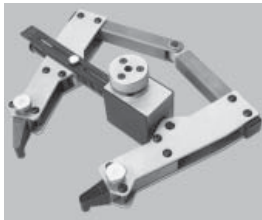

- Usable with any internal or external retaining ring from a diameter of 400 - 1000mm (15" - 40".)
- Securely opens, closes and holds rings due to a self-locking precision spindle action.
- For fitting and removing retaining rings in one operation.
- Holds rings securely due to short, direct-contact sockets.
- High-strength, hardened and tempered tips.
- Opening width up to 250mm (with scale on request.)
- Can be operated with Allen key (Hexagonal key), ratchet wrench or cordless screwdriver.
- Interchangeable paired tips to cover different diameter ranges.



Interchangeable paired tips to cover different diameter ranges.

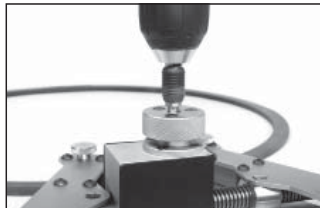

Automated operation.

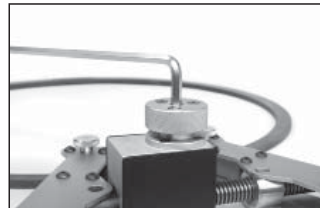

Manual operation.

USABLE FOR ANY APPLICATIONS WHERE LARGE SHAFTS AND BEARINGS TRANSMIT VERY HIGH FORCES AND TORQUES:

- Wind power plants / tidal facilities
- Generator engineering / hydroelectric power facilities
- Heavy plant engineering (rolling mill / press construction)
- Shipbuilding
- Aerospace

*Please wear protective eyewear while installing and removing retaining rings & hose clamps.*

# Hose Clamp Tools Pneumatic

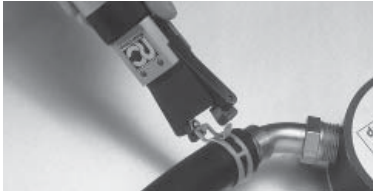

## Pneumatic Hose Clamp Tools

Pneumatic Hose Clamp Tools use a compressed air line of 90 psi, and are activated by a simple lever reducing stress on the hand from repeated assembly/disassembly. Tangs of the clamp fit in the jaws of the tool and are compressed for installation or removal on the hose. Helps eliminate carpal tunnel syndrome.



### PWS Pneumatic Tool

For use with Rotor Clamp Single Wire (HC/HW) hose clamps



### PWD Pneumatic Tool

For use with Rotor Clamp Double Wire (DW) hose clamps



Single Wire (HC/HW) Hose Clamp Pneumatic Tool (PWS). Designations for individual clamp sizes are listed left.



Double Wire (DW) Hose Clamp Pneumatic Tool (PWD). Designations for individual clamp sizes are listed left.

Rotor Clamp HC No.	Pneumatic Installation Tool	Rotor Clamp HC No.	Pneumatic Installation Tool
HC-4	PWS-4	HC-19	PWS-19
HC-5	PWS-5	HC-19.5	PWS-19.5
HC-5.5	PWS-5.5	HC-20	PWS-20
HC-6	PWS-6	HC-21	PWS-21
HC-7	PWS-7	HC-22	PWS-22
HC-7.5	PWS-7.5	HC-23	PWS-23
HC-8	PWS-8	HC-24	PWS-24
HC-8.5	PWS-8.5	HC-25	PWS-25
HC-9	PWS-9	HC-26	PWS-26
HC-9.5	PWS-9.5	HC-28	PWS-28
HC-10	PWS-10	HC-30	PWS-30
HC-10.5	PWS-10.5	HC-31	PWS-31
HC-11	PWS-11	HC-32	PWS-32
HC-12	PWS-12	HC-34	PWS-34
HC-13	PWS-13	HC-35	PWS-35
HC-14	PWS-14	HC-36	PWS-36
HC-15	PWS-15	HC-38	PWS-38
HC-16	PWS-16	HC-40	PWS-40
HC-17	PWS-17	HC-42	PWS-42
HC-17.5	PWS-17.5	HC-46	PWS-46
HC-18	PWS-18	HC-50	PWS-50
HC-188	PWS-188		

Rotor Clamp DW No.	Pneumatic Installation Tool	Rotor Clamp DW No.	Pneumatic Installation Tool
DW-4.5	PWD-4.5	DW-17	PWD-17
DW-5	PWD-5	DW-17.5	PWD-17.5
DW-5.5	PWD-5.5	DW-18	PWD-18
DW-6	PWD-6	DW-19	PWD-19
DW-6.5	PWD-6.5	DW-19.5	PWD-19.5
DW-7	PWD-7	DW-20	PWD-20
DW-8	PWD-8	DW-21	PWD-21
DW-8.5	PWD-8.5	DW-22	PWD-22
DW-9	PWD-9	DW-22.5	PWD-22.5
DW-9.5	PWD-9.5	DW-23	PWD-23
DW-10	PWD-10	DW-24	PWD-24
DW-10.5	PWD-10.5	DW-25	PWD-25
DW-11	PWD-11	DW-26	PWD-26
DW-11.5	PWD-11.5	DW-27	PWD-27
DW-12	PWD-12	DW-28	PWD-28
DW-12.5	PWD-12.5	DW-30	PWD-30
DW-13	PWD-13	DW-31	PWD-31
DW-14	PWD-14	DW-32	PWD-32
DW-14.5	PWD-14.5	DW-34	PWD-34
DW-15	PWD-15	DW-35	PWD-35
DW-16	PWD-16	DW-36	PWD-36



### PBC-1 Pneumatic Tool

For use with Rotor Clamp Constant Tension Band (CTB) hose clamps.

Specify **PBC-1** for any Rotor Clamp CTB Hose Clamp you are installing. One size fits all.



*Please wear protective eyewear while installing and removing retaining rings & hose clamps.*

# Hose Clamp Tools Manual



## KC-18 Pliers

For use with single wire "HC" hose clamps:



## Single Wire Hose Clamp Plier (KC-18)

Install Rotor Clamp Single Wire (HC) hose clamps quickly and easily using this simple hand tool. **ONE SIZE FITS ALL.** Specify **KC-18** for any Rotor Clamp Single Wire (HC) hose clamp you are installing.

## HAZ-2 Pliers

For use with single wire "HC" hose clamps:

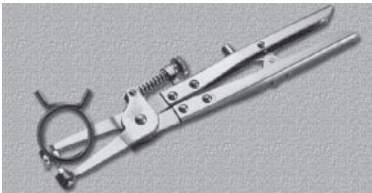

## Single Wire Hose Clamp Plier - Heavy Duty (HAZ-2)

A heavy-duty version of the Single Wire Pliers (KC-18). Tool locks into place when clamp is fully compressed, relieving hand pressure when installing/removing. Tips can be adjusted to desired clamp opening to ensure fast, consistent installation or removal. **ONE SIZE FITS ALL.** Specify **HAZ-2** for any Rotor Clamp Single wire (HC) hose clamp you are installing.

## HAZ-1 Pliers

For use with Constant Tension Band "CTB" hose clamps:

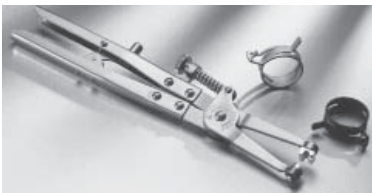

## Constant Tension Band Hose Clamp Plier (HAZ-1)

A rugged easy-to-use application tool for CTB hose clamps. Tool locks into place when clamp is fully compressed, relieving hand pressure when installing/removing. Tips can be adjusted to desired clamp opening to ensure fast, consistent installation or removal. **ONE SIZE FITS ALL.** Specify **HAZ-1** for any Rotor Clamp Constant Tension Band (CTB) hose clamp you are installing.





# Retaining Ring Plier Kits



## Retaining Ring Plier Kits

Stock the tools you use the most with any or all of these four retaining ring plier kits. Rugged carrying cases provide portability and durability in a manufacturing/factory environment. Tools are designed to fit a wide range of sizes from 3/8" to 4" diameter retaining rings, meeting most everyday MRO requirements. Rotor Clip Plier Kits can be easily stored on a bench or in a maintenance cabinet/storage area. Descriptions and specifications follow.

### Retaining Ring Plier Kits

For use with the following retaining rings:



\*\* Convertible Plier Kit only



### Replaceable Tip Pliers Kit (RPK#1)

Contains one internal and one external plier in a reusable, clear plastic case. Features eight pair of replaceable tips that can be easily affixed to the end of

the pliers to cover internal/external retaining rings from 3/8" to 2" . . . Small enough to fit in your pocket!



### Convertible Pliers Kit (RPK#3)

Contains 12 pliers which can be easily converted from internal to external and back again. Includes straight, 45° and 90° tip pliers that

will fit retaining rings up to 2" in diameter. Does the work of 24 individual tools!



### Ratchet Pliers Kit (RPK#2)

Features two ratchet pliers for internal/external retaining rings. Handles larger retaining rings up to 4". Ratchet mechanism compresses

(internal rings) and/or expands (external rings) through gradual steps, minimizing operator fatigue and effort.



### Mini Convertible Pliers Kit (RPK#6)

This abbreviated version of the RPK#3 features 6 pliers in straight and 90° configurations that will fit retaining rings up to 2" in diameter. Durable plastic case is easily stored

in the tightest of spaces.



# Retaining Ring Kits

### RPK#4 Retaining Ring Kit

Contains the following styles of retaining rings:



### Rotor Pack (RPK#4)



Rotor Pack features 1,000 retaining rings in four durable, clear-plastic boxes with easy snap on/off lids. Boxes fit into slots on a plastic holder which folds in half into a convenient, portable carrying case.

Rotor Pack contains internal ring sizes that will fit housings/bores from 3/8" in diameter to 1-1/8". External rings in the kit will accommodate shaft sizes from 1/4" to 1-1/8". Contains 2 pliers to fit every ring in the kit.

#### ROTOR PACK - RPK #4

Rotor Clip Number	Housing Dia. (In.)	Qty.	Rotor Clip Number	Shaft Dia. (In.)	Qty.
HO-37	3/8	50	SH-25	1/4	50
HO-43	7/16	50	SH-31	5/16	50
HO-50	1/2	50	SH-37	3/8	50
HO-56	9/16	50	SH-43	7/16	50
HO-62	5/8	50	SH-50	1/2	50
HO-75	3/4	50	SH-56	9/16	50
HO-87	7/8	50	SH-62	5/8	50
HO-100	1	50	SH-75	3/4	50
HO-112	1-1/8	50	SH-87	7/8	50
			SH-100	1	50
			SH-112	1-1/8	50

### RPK#5 "E" Retaining Ring Kit

Contains the following styles of retaining rings:



### Rotor Pack, Jr. (RPK#5)



Rotor Pack Jr. contains over 1,500 "E" retaining rings in four durable, clear plastic boxes with easy snap on/off lids. Boxes fit into slots on a plastic holder which folds in half into a convenient, portable carrying case.

Rotor Pack Jr. contains "E" rings accommodating shaft sizes from 1/16" in diameter to 1-3/16".

#### ROTOR PACK JR. - RPK#5

Rotor Clip Number	Shaft Dia. (In.)	Qty.	Rotor Clip Number	Shaft Dia. (In.)	Qty.
E-6	1/16	200	E-62	5/8	40
E-9	3/32	150	E-75	3/4	15
E-12	1/8	150	E-87	7/8	15
E-14	9/64	100	SE-9	3/32	150
E-15	5/32	100	SE-11	7/64	150
E-18	3/16	100	SE-17	11/64	100
E-25	1/4	50	SE-21	7/32	50
E-37	3/8	50	SE-31	5/16	50
E-43	7/16	50	SE-98	63/64	15
E-50	1/2	40	SE-118	1-3/16	12

*Please wear protective eyewear while installing and removing retaining rings & hose clamps.*

# Automated Assembly Axial Rings



Automated Assembly is used in the manufacturing process as a cost reduction tool that additionally achieves increased production rate and added quality through repeatability. The same holds true for automated assembly of retaining rings. Parts can be assembled fast, reducing costs without sacrificing quality. Properly designed installation equipment shuttles the ring into the groove without disruption and guards against permanent set (overstretching/over-compressing of ring) to ensure a tight fit.

## Design Considerations

Feed equipment should be designed to work with rings meeting standard specifications. Most critical is to design equipment that can accommodate the helix and pitch limitations for the type of ring you are using. If the equipment is sensitive to any of these factors, it will require special processing that will add to your costs. Design guidelines include:

1. Consider use of a tapered mandrel for external retaining rings and a tapered housing for internal retaining rings (see illustrations). It is not recommended to pick up and transfer rings by the lug holes.
2. Feed parts onto the tapered mandrel or into the tapered housing using a "feed finger" mechanism. Make sure the rings are fed in the proper direction and in the proper manner as depicted to avoid sensitivity to ring pitch.
3. Feed finger thickness should be sized per ring: 80% of the ring minimum thickness. (For example: If ring thickness is .025" +/- .002, feed finger should be .018" thick -- .023 X 80%.)
4. Limit shuttle distance to a minimum from feed mandrel to installation on assembly.
5. Do not incorporate extension sleeves to tapered mandrel/tapered housing. This may exceed the expansion/compression limits of the ring causing it to fail. (Note: extension sleeves are typically used to guard against scratching/marring the finish of the shaft or housing. If this is a concern, please consult Rotor Clip Technical Sales).
6. Incorporate complementary chamfers to the assembly and installation mandrels.

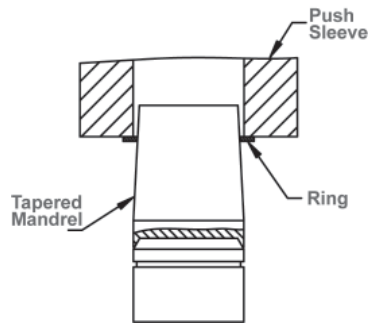

### EXTERNAL

Use tapered mandrel to expand ring and install in groove on shaft. (Note: angle of inclination of taper should be 3-5 degrees).

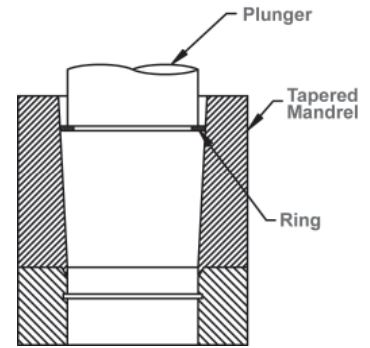

### INTERNAL

Use tapered housing to compress ring and install in groove in housing. (Note: angle of inclination of taper should be 3-5 degrees).



**Figure A** - This is the preferred way to transfer feed an internal ring into a tapered housing by inserting the mechanism between the lugs (Note: Finger thickness should be 80% of the minimum ring thickness).



**Figure B** - This is the preferred way to transfer feed an external ring onto a tapered mandrel by using a slide with a complementary cut out for the lugs. (Note: Finger thickness should be 80% of the minimum ring thickness).

**Contact Technical Sales for more information:  
tech@rotorclip.com  
+1 732.469.7333**



## Static Thrust Loads

### 1. ALLOWABLE THRUST LOADS - RINGS ( $P_r$ or $P'_r$ )

Maximum allowable static thrust capacities for rings normally used with grooves are listed in the data charts for each ring type. The load limits are given for rings ( $P_r$  or  $P'_r$ ) and grooves ( $P_g$ ).

The values for  $P_r$  or  $P'_r$  are applicable only when the ring is installed in a housing or on a shaft made of hardened steel where the thrust load capacity of the groove is equal to or greater than that of the ring. When the ring is seated in a groove cut in softer material, and  $P_g$  is less than  $P_r$  or  $P'_r$ ,  $P_g$  becomes the limiting factor in the assembly.

For maximum thrust capacity in both static and dynamic loading, the abutting face of the retained part should have a square corner. Fit of the retained part in the housing or on a shaft should allow reasonably concentric uniform loading against the ring.

When there is radial play between the retained part and the shaft or housing, such play must be treated as though the retained part had a chamfered corner. The magnitude of the chamfer should be considered equal to the play. Loading data for rings abutted by chamfered parts ( $P'_r$ ) as shown in the specific ring data charts must be considered. (See CORNER RADII & CHAMFERS, page 257, right column.)

Allowable load capacities for rings ( $P_r$ ) apply only to standard thickness rings made of standard materials using the shear strength values listed in Table 1, below, left.

When the following special materials are used, multiply the allowable thrust load of the ring by the conversion factor shown below.

Ring Material	Type	Rotor Clip Code	Conversion Factor All Sizes
Stainless Steel	PH 15-7Mo or equivalent AISI 632-AMS 5520	SS	1.0
Beryllium Copper*	Alloy = 25, UNS C17200	BC	0.75

\* Except those noted in Table 1.

### 2. ALLOWABLE THRUST LOADS — GROOVES ( $P_g$ )

The allowable thrust loads listed in column  $P_g$  of the data charts for rings used in grooves are based upon a housing or shaft material of cold rolled steel with a tensile yield strength of 45,000 psi. In the case of Series VHO and VSH beveled rings, the values given are for minimum contact between ring and groove—i.e., engagement of the beveled edge of the ring with the beveled groove wall at a length equal to half of the groove depth ( $d/2$ ).

When the following materials are used, multiply the allowable thrust load of the groove by the conversion factor shown below.

Groove Material	Tensile Yield Strength Type	Conversion Factor
Hardened Steel (RC-40)	150,000 psi	3.3
Hardened Steel (RC-50)	200,000 psi	4.45
Aluminum (2024-T4)	40,000 psi	0.89
Brass (Naval)	30,000 psi	0.66
Other	x psi	x psi/45,000

Table 1: Shear Strength of Ring Material

Material	Ring Series	Ring Thickness (in.)	Shear Strength (psi)
Carbon Spring Steel (SAE 1060-1090)	HO	Up to and including .035	120,000
	SH		
	BHO		
	BSH	.042 and over	150,000
	VHO		
	VSH		
	HOI		
	SHI		
	C	.035 and over	150,000
	SHR		
	SHM		
		.020 and .025	120,000
	.035 and over	150,000	
Beryllium Copper (Alloy #25 UNS C17200)	LC	All available	150,000
	RE		
	PO/POL		
	BE	.010 and .015	100,000
	E	.025	120,000
		.035 and over	150,000
	EL	All available	130,000
		.010 and .015 (Sizes -12 thru -23)	110,000
	.015 (Sizes -18 thru -23)	110,000	
	.010 (Size -4 only)	95,000	



# Load Capacities Formulas

## 3. CALCULATING EDGE MARGIN

The distance from the groove to the end of the shaft or housing is known as edge margin. Edge margin is a calculated distance based on the relationship between the edge margin ( $y$ ) and the groove depth ( $d$ ). When  $y/d \geq 3$ , the groove will withstand the maximum thrust load as indicated in the Rotor Clip catalog specification page for that particular size and type of retaining ring.

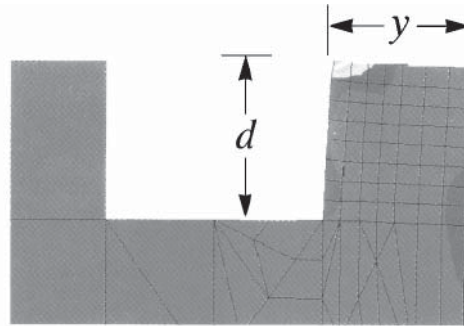

Example: SH-50 external retaining ring installed on a cold-rolled steel shaft. The catalog specifications for this ring call for a minimum edge margin of 0.048" and a groove depth of 0.016." Our formula is as follows:

$$y/d \geq 3 \frac{0.048''}{0.016''} = 3$$

There is sufficient edge margin for the groove to withstand the maximum thrust load of 550lbs. listed in the catalog specifications. If an application requires an edge margin less than the recommended specifications, it is necessary to calculate the thrust load ( $P_g$ )-capacity of the groove, to determine if the reduced margin is capable of handling the anticipated thrust load. The following formula applies (Note: see Correction Factors table for  $G_f$  value; Yield Strength of Groove Material for  $\sigma_y$  value; Edge Margin Graph for  $K_1$  value; Nomenclature Table for remaining catalog specifications):

$$P_g = \frac{G_f D_s d \pi \sigma_y}{K_1 F_s}$$

For this example, assume that the edge margin will only be half the listed catalog value or,  $y/d = 1.5$ . The above equation is as follows:

$$\begin{aligned} P_g &= \frac{(1) .5 \times .016 \times 3.14 \times 45,000}{2.20 (2)} \\ &= \frac{1130.4}{4.40} \\ &= 256.9 \text{ lbs.} \end{aligned}$$

Maximum thrust load for reduced edge margin

Finite Element Analysis shows stress gradients for a retaining rings in an application with insufficient edge margin. When loaded, the high stress region extends over the entire groove wall to the end of the shaft (or housing) and the groove wall actually distorts. Under these conditions, the ring would buckle, possibly leading to catastrophic failure.

### EDGE MARGIN

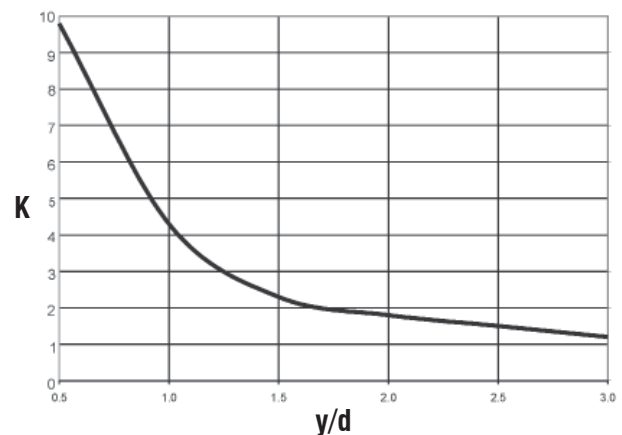

Yield Strength of Groove Material	
Groove Material	Yield Strength (psi)
Cold-drawn steel (SAE 1010)	45,000
Steel (SAE 1045, Rc 42)	185,000
Steel (SAE 1045, Rc 48)	220,000
Aluminum (2042-T4, Rb 75)	48,000
Naval Brass (Rb 82)	53,000

Correction Factors	
Ring Series	Correction Factor, $G_f$
HO, MHO	1.20
SHI, HOI	0.50
SH, MSH	1.00
C, MC	0.50
E, ME	0.33
RE, MRE	0.25
SHR, MSR	2.00
PO	0.50
SHM	1.00

Nomenclature Table	
$d$	= Groove depth, in.
$D_s$	= Shaft or housing diameter, in.
$F_s$	= Safety Factor
$G_f$	= Correction Factor
$K_1$	= Edge Margin
$P_g$	= Thrust Load on Groove, lb.
$\sigma_y$	= Tensile Yield Strength of groove material, psi

**For Technical Assistance,  
e-mail [tech@rotorclip.com](mailto:tech@rotorclip.com)**



# Formulas Load Capacities

## 4. THICKNESS OF HOUSINGS AND HOLLOW SHAFTS

The allowable load of a part in which a retaining ring groove is cut depends upon the ultimate tensile strength and tensile yield strength of the material used, and on the bearing area of the ring against the groove wall. For internal rings used in bores and housings — and external rings assembled on hollow shafts — wall thickness dimension  $w$ , illustrated below, can be calculated from the formulas:

For internal rings:

$$w = \sqrt{\frac{3G_f D_s d \sigma_y}{\sigma_u} + \frac{D_g^2}{4}} - \left[ \frac{D_s}{2} \right]$$

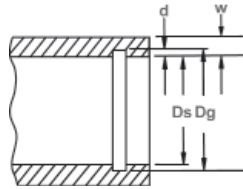

For external rings:

$$w = \frac{D_s}{2} - \sqrt{\frac{D_g^2}{4} - \frac{3G_f D_s d \sigma_y}{\sigma_u}}$$

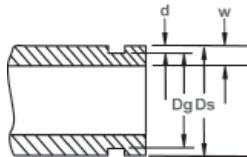

where:

- $D_s$  = Shaft or housing dia. (in.)
- $D_g$  = Groove dia. (in.)
- $G_f$  = Correction Factor [See Table 2, Page 255]
- $d$  = Groove depth (in.)
- $\sigma_y$  = Tensile yield strength of groove material (psi)  
[See Table 3, Page 258]
- $\sigma_u$  = Ultimate tensile strength of groove material (psi)

These formulas provide for a wall thickness that is safe for allowable groove thrust loads ( $P_g$ ) calculated with the formula at the right. If substantially lighter loads will be encountered and a thinner wall is desired, actual tests are recommended.

## 5. LOAD LIMIT FORMULAS

Formulas for determining ring and groove load limits — with sample calculations for Series HO internal rings and Series SH external rings — are given below. The loads are calculated for retained parts having sharp corners. Correction factors ( $G_f$ ) for calculating  $P_r$  and  $P_g$  are given in Table 2 on right. The correction factors are based upon the load characteristics of the rings.

In these examples assume  $y \geq 3d$ . Therefore,  $K = 1$  (see previous page) and is not shown in formulas for  $P_g$ .

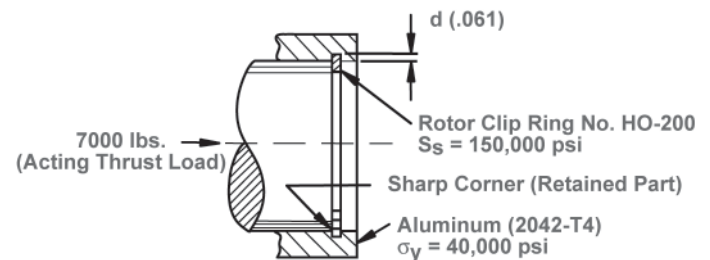

### Internal Ring (Example: Series HO-200)

ALLOWABLE THRUST LOAD — RING ( $P_r$  in lbs.)

$$P_r = \frac{G_f D_h T \pi S_s}{F_s}$$

where:

- $G_f$  = Conversion Factor [See Table 2, Page 255]
- $D_h$  = Housing dia. (in.)
- $T$  = Ring thickness (in.)
- $S_s$  = Shear Strength of ring material (psi)  
[See Table 1, Page 252]
- $F_s$  = Safety factor

$$P_r = \frac{(1.2) 2.000 (.062) \pi 150,000}{4} = 17,500 \text{ lbs.} > 7000 \text{ lbs.}$$

**For Technical Assistance,  
e-mail [tech@rotorclip.com](mailto:tech@rotorclip.com)**





# Load Capacities Formulas



## ALLOWABLE THRUST LOAD — GROOVE ( $P_g$ in lbs.)

$$P_g = \frac{G_f D_H d \pi \sigma_y}{F_S}$$

where:

$G_f$  = Correction Factor [See Table 2, right]

$D_H$  = Housing dia. (in.)

$d$  = Groove depth (in.)

$\sigma_y$  = Tensile yield strength of groove material (psi)  
[See Table 3, Page 258]

$F_S$  = Safety factor

$$P_g = \frac{(1.2) 2.000 (.061) \pi 40,000}{2} = 9200 \text{ lbs.} > 7000 \text{ lbs.}$$

## ALLOWABLE THRUST LOAD — GROOVE ( $P_g$ in lbs.)

$$P_g = \frac{G_f D_S d \pi \sigma_y}{F_S}$$

where:

$G_f$  = Conversion Factor [See Table 2, below]

$D_S$  = Shaft dia. (in.)

$d$  = Groove depth (in.)

$\sigma_y$  = Tensile yield strength of groove material (psi)  
[See Table 3, Page 258]

$F_S$  = Safety factor

$$P_g = \frac{(1) 1.000 (.030) \pi 45,000}{2} = 2100 \text{ lbs.} > 2000 \text{ lbs.}$$

Note: For series RE only: Substitute value of groove diameter ( $D_g$ ) for shaft diameter ( $D_S$ )

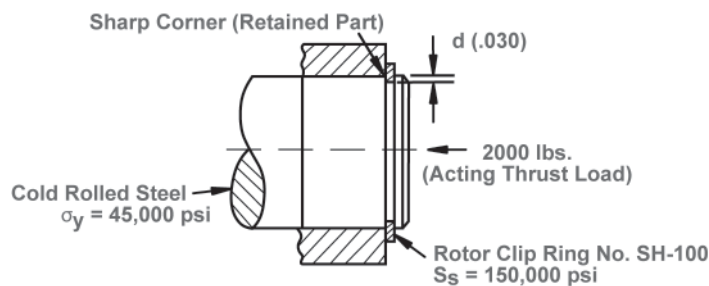

Table 2: Correction Factors ( $G_f$ ) for Calculating  $P_r$  and  $P_g$

Ring Series	Correction Factor $G_f$	
	Ring: $P_r$	Groove: $P_g$
HO, BHO, MHO	1.2	1.2
VHO	1.2	1.2 (Use d/2 instead of d)
HOI, SHI	2/3	1/2
SH, BSH, MSH	1	1
VSH	1	1 (Use d/2 instead of d)
C, MC	1/2	1/2
LC	3/4	3/4
BE, E, ME	1/3	1/3
RE, MRE	1/4	1/4
EL	Use listed data chart values	1/2
SHR, MSR	1.3	2
PO	1/2	1/2
SHM	Inquire	1

## External Ring (Example: Series SH-100)

### ALLOWABLE THRUST LOAD — RING ( $P_r$ in lbs.)

$$P_r = \frac{G_f D_S T \pi S_S}{F_S}$$

where:

$G_f$  = Conversion Factor [See Table 2, right]

$D_S$  = Shaft dia. (in.)

$T$  = Ring thickness (in.)

$S_S$  = Shear Strength of ring material (psi)  
[See Table 1, Page 252]

$F_S$  = Safety factor

$$P_r = \frac{(1) 1.000 (.042) \pi 150,000}{4} = 4950 \text{ lbs.} > 2000 \text{ lbs.}$$





## Dynamic Thrust Loads

Dynamic conditions most often encountered in retaining ring assemblies include sudden loading, impact, vibration, and relative rotation. Very often the loading pattern is cyclical in nature and may induce fatigue in the assembly. Where dynamic loads are likely to exist, it is necessary that actual tests of such applications be made by the ring user to insure proper functioning of the assembly. The following formulas are given for calculating the ring and or groove thrust load capacity for various conditions.

### 1. SUDDEN LOADING

This can occur when a surge in thrust load is transmitted to a ring installed in a tight assembly, without play between the retained part and the ring. Sudden loads of this nature should not exceed, at their maximum, 50% of the allowable static thrust load ( $P_r$  or  $P_g$ , whichever is lower).

### 2. IMPACT LOADING

To calculate the safe impact load capacity of the ring ( $I_r$ ), the following formula should be used:

$$I_r = \frac{P_r t}{2}$$

where:  $I_r$  = Allowable impact load (in. lbs.)  
 $P_r$  = Allowable thrust load of ring (lbs.)  
 $t$  = Ring thickness (in.)

The formula for calculating the safe impact load capacity of the groove ( $I_g$ ) is:

$$I_g = \frac{P_g d}{2}$$

where:  $I_g$  = Allowable impact load (in. lbs.)  
 $P_g$  = Allowable thrust load of groove (lbs.)  
 $d$  = Nominal groove depth (in.)

### • Internal Ring (Example: Series HO-200)

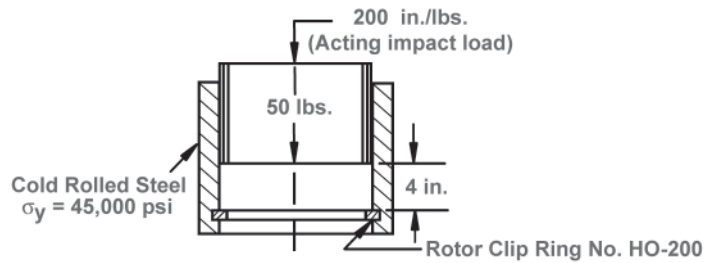

FOR THE RING:

$$I_r = \frac{P_r t}{2} = \frac{17,500 (.062)}{2}$$

$$= 540 \text{ in. lbs.} > 200 \text{ in. lbs.}$$

FOR THE GROOVE:

$$I_g = \frac{P_g d}{2} = \frac{10,400 (.061)}{2}$$

$$= 320 \text{ in. lbs.} > 200 \text{ in. lbs.}$$

### 3. VIBRATION LOADING

It is possible to calculate the approximate vibration load capacity of a ring and groove if there is a tight fit between the ring and the abutting retained part. (If there is space between the ring and the part, the load capacity must be calculated as impact.)

The formula for calculating the vibration load capacity of the ring is:  $wa \leq 540 P_r$

where:  $w$  = Weight of retained parts (lbs.)  
 $a$  = Acceleration of parts (in./sec.<sup>2</sup>)  
 $P_r$  = Allowable thrust load of ring (lbs.)

To calculate the vibration load capacity of the groove, the formula is:  $wa \leq 400 P_g$

where:  $w$  = Weight of retained parts (lbs.)  
 $a$  = Acceleration of parts (in. sec.<sup>2</sup>)  
 $P_g$  = Allowable thrust load of groove (lbs.)



# Load Capacities Formulas

Harmonic oscillation for both ring and groove may be calculated with the following formula:  $a \cong 40 pf^2$

where:  $a$  = Acceleration of parts (in./sec.<sup>2</sup>)  
 $p$  = Amplitude (in.)  
 $f$  = Frequency (cycles/sec.)

• Sample Calculation (Example: Series SH-200)

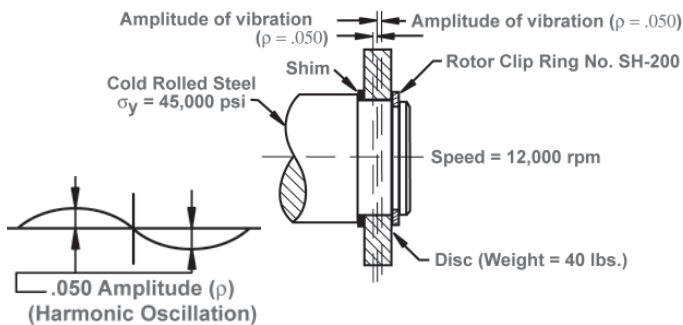

FOR THE RING:  $wa \leq 540 P_r$

For harmonic oscillation:

$$a \cong 40 pf^2$$

$$f = \frac{12,000}{60} = 200 \text{ cycles/sec.}$$

$$a \cong 40 (.050) 200^2 = 80,000 \text{ in./sec.}^2$$

$$wa = (40) (80,000) = 3.2 \times 10^6$$

$$540 P_r = (540) (14,600) = 7.9 \times 10^6$$

$$\therefore wa < 540 P_r \text{ and ring is safe}$$

FOR THE GROOVE:

$$wa \leq 400 P_g$$

$$wa = 3.2 \times 10^6$$

$$400 P_g = (400) (8050) = 3.22 \times 10^6$$

$$\therefore wa < 400 P_g \text{ and groove strength is adequate.}$$

## Corner Radii and Chamfers - $R_{max}$ and $Ch_{max}$

All of the formulas above and the values for  $P_r$  given in the data charts for each ring type are calculated for assemblies in which the retained parts have square corners. If the abutting face of the retained part has a corner radius or chamfer, the assembly's thrust load capacity will be lower. A Series HO-100 ring which abuts a square-cornered part, for example, has a static thrust capacity of 5,950 lbs. The same ring, seated next to a part having the maximum allowable corner radius or chamfer, has an allowable load of 1,650 lbs.

Maximum allowable corner radii and chamfers for each ring size are listed in the charts with corresponding static thrust capacities. If these thrust capacities are not sufficient for the assembly, a rigid square-cornered flat washer should be inserted between the part and the ring. The thrust capacity of the assembly will then be approximately the same as if a square-cornered retained part had been used.

When the actual corner radius or chamfer is less than the listed maximum, the allowable thrust load of the assembly increases proportionately in accordance with the following formulas:

$$P''_r = P'_r \frac{R_{max.}}{R} \quad (\text{for radius})$$

$$P''_r = P'_r \frac{Ch_{max.}}{Ch} \quad (\text{for chamfer})$$

where:  $P''_r$  = Allowable assembly load when corner radius or chamfer is less than listed maximum  
 $P'_r$  = Listed allowable assembly load with maximum corner radius or chamfer  
 $R_{max.}$  = Listed maximum allowable corner radius  
 $R$  = Actual corner radius  
 $Ch_{max.}$  = Listed maximum allowable chamfer  
 $Ch$  = Actual chamfer

(Continued on next page...)



# Formulas Load Capacities

## Corner Radii and Chamfers - $R_{max}$ and $Ch_{max}$

Continued...

- Sample Calculation (Example: Series SH-125)

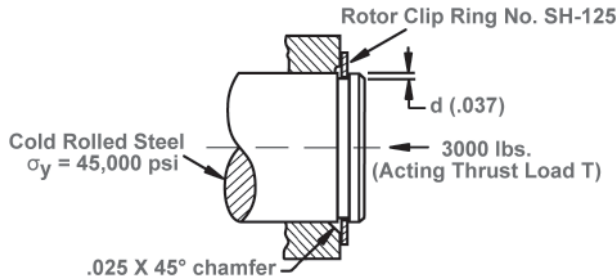

ALLOWABLE THRUST LOAD — RING ( $P''_r$  in lbs.)

$$P''_r = P'_r \frac{Ch_{max.}}{Ch} = \frac{(1950) (.041)}{.025}$$

$$P''_r = 3200 \text{ lbs.} > 3000 \text{ lbs.}$$

ALLOWABLE THRUST LOAD — GROOVE ( $P_g$  in lbs.)

$$P_g = \frac{G_f D_s d \pi \sigma_y}{F_s} \quad (\text{See formula derivation page 253})$$

$$P_g = \frac{(1) 1.250 (.037) \pi (45,000)}{2}$$

$$P_g = 3270 \text{ lbs.} > 3000 \text{ lbs.}$$

NOTE: If the allowable thrust load capacity of the ring ( $P_r$ ) or the groove ( $P_g$ ) is less than  $P''_r$ ,  $P_r$  or  $P_g$  — whichever is lower — becomes the limiting factor in the assembly.

### ELASTIC DEFORMATION WITH CORNER RADII OR CHAMFERS

Elastic deformation of an assembly (retained part, retaining ring and groove wall) where the retained part has a corner radius or chamfer can be calculated with the following formulas:

$$\delta = \frac{T (.01) D_s (R + t/4)}{(P''_r) t} \quad (\text{for radius})$$

$$\delta = \frac{T (.01) D_s (Ch + t/4)}{(P''_r) t} \quad (\text{for chamfer})$$

where:  $\delta$  = Deflection (in.)

$T$  = Acting thrust load (lbs.)

$D_s$  = Shaft or housing dia. (in.)

$R$  = Actual radius (in.)

$Ch$  = Actual chamfer (in.)

$t$  = Ring thickness (in.)

$P''_r$  = Allowable thrust load of ring when actual corner radius or chamfer is less than listed maximum (lbs.)

NOTE:  $R$  and  $Ch$  cannot exceed the values for  $R_{max}$  and  $Ch_{max}$  listed in the data charts for the individual ring types.

- Sample Calculation (Example: Series SH-125)

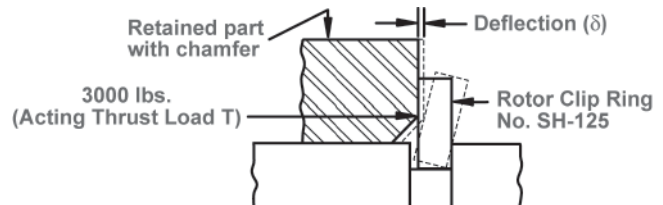

$$\delta = \frac{T (.01) D_s (Ch + t/4)}{(P''_r) t}$$

$$\delta = \frac{(3000) (.01) (1.250) (.025 + .0125)}{(3200) (.050)} \cong .0087 \text{ in.}$$

Table 3: Tensile Yield Strength of Groove Material

Groove Material	Tensile Yield Strength (psi)
Cold-drawn steel (SAE 1010)	45,000
Hardened steel (RC-40)	150,000
Hardened steel (RC-50)	200,000
Steel (SAE 1045, Rc 42)	185,000
Steel (SAE 1045, Rc 48)	220,000
Aluminum (2024-T4)	40,000
Aluminum (2042-T4, Rb 75)	48,000
Naval Brass	30,000
Naval Brass (Rb 82)	53,000

Table 4: Maximum Working Stress of Ring During Expansion or Contraction

Ring Material	Rotor Clip Code	Maximum Allowable Working Stress (psi)
Carbon Spring Steel (SAE 1075)	ST	250,000
Stainless Steel (PH 15-7 Mo)	SS	250,000
Beryllium Copper (Alloy #25)	BC	200,000



## Relative Rotation

When a retained part rotates relative to and exerts thrust on the ring, frictional forces act on the ring body. Relative rotation can reduce substantially the thrust capacity of the assembly. The use of a keyed washer or other non-rotating device between ring and retained part to eliminate relative rotation should be considered.

To prevent the rings from being “walked out” or otherwise unseated from the groove, maximum allowable rotating thrust loads may be calculated from the following formula:

$$P_{rr} \leq \frac{s t E^2}{\mu 18 D_s}$$

where:  $P_{rr}$  = Allowable thrust load exerted by adjacent part (lbs.)  
 $s$  = Maximum working stress of ring during expansion or contraction [See Table 4, left]  
 $t$  = Ring thickness (in.)  
 $E$  = Largest section of ring (in.)  
 $\mu$  = Coefficient of friction between ring and retained part or groove whichever is higher (consult appropriate references)  
 $D_s$  = Shaft or housing dia. (in.)

- Sample Calculation (Example: Series SH-150)

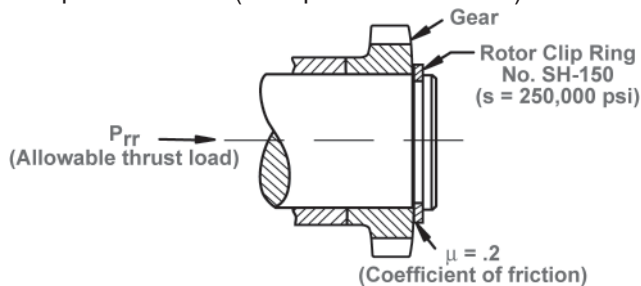

$$P_{rr} \leq \frac{s t E^2}{\mu 18 D_s}$$

$$P_{rr} \leq \frac{250,000 (.050) (.168)^2}{.2 (18) (1.500)} = 65 \text{ lbs. max.}$$

NOTE: Relative rotation applies to the following rings made of standard materials when used in grooves: Series HO, BHO, VHO, HOI, SH, BSH, VSH, C,SHI, BE, E, RE, SHR, PO, SHF and SHM. Series LC and EL are not affected.



## Deflection

Permanent deflection of ring assemblies (retained part, retaining ring and groove wall), permitting movement of the retained parts, is negligible when loads do not exceed the governing allowable thrust load (static, impact, vibration, etc. — whichever is present).

Elastic deformation, which is a temporary displacement of the retained part under load, can be calculated by the following formula:

$$\delta = \frac{T}{E d}$$

where:  $\delta$  = Deflection (in.)  
 $T$  = Acting load (lbs.)  
 $E$  = Modulus of elasticity of groove material  
 $d$  = Groove depth (in.)

- Sample Calculation (Example: Series SH-100)

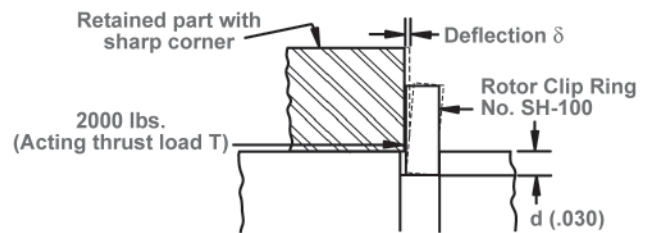

$$\delta = \frac{T}{E d} = \frac{2000}{3 \times 10^7 (.030)} = .0022''$$

**For Technical Assistance,  
e-mail [tech@rotorclip.com](mailto:tech@rotorclip.com)**



# Formulas Beveled Retaining Rings

The purpose of beveled rings, when used within their specified limits, is to assure the user that in all assemblies there will always be an axial force exerted on the retained part by the retaining ring. This concept is illustrated below:

$$\text{Ring take-up capability } [d/2 (\tan 15^\circ)] \geq \Delta A + \Delta B + \Delta U$$

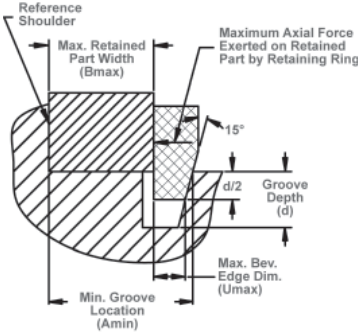
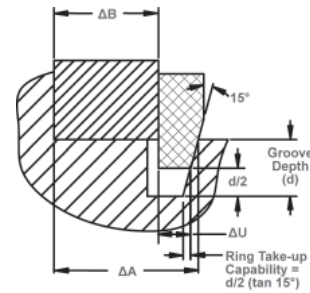

**Ring Seated at Minimum Depth**

If the take-up requirement is satisfied, the groove location limits (Amin & Amax) can be calculated as follows:

$$A_{min} = B_{max} + U_{max} + d/2 (\tan 15^\circ)$$

$$A_{max} = B_{min} + U_{min} + d (\tan 15^\circ)$$

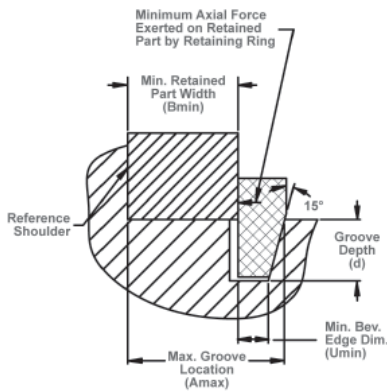

**Ring Seated at Maximum Depth (Near Groove Bottom)**

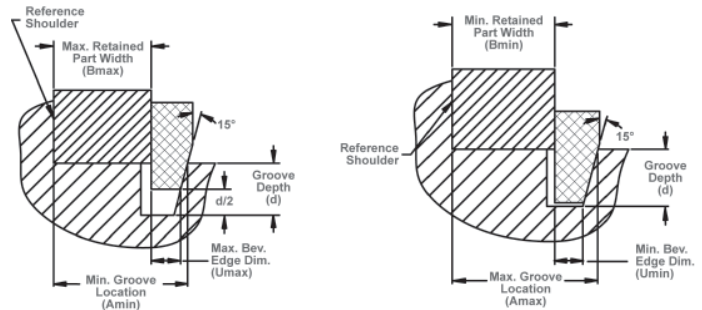

As an example of this technique, assume that a VHO-200 ring is used to retain a part with a width dimension of  $1.000 \pm .002$ .

The groove location limits will be as follows:

$$A_{min} = 1.002 + .045 + .072/2 (\tan 15^\circ) = 1.057$$

$$A_{max} = .998 + .043 + .072 (\tan 15^\circ) = 1.060$$

If the user's ability to locate the groove requires less than the .003 allowable tolerance, the maximum seating depth position can be moved up the groove to provide a higher minimum axial force.

Until now, the explanation has focused on a technique which will assure that 100% of the assemblies will have the ring seated within the limits shown. If the user will accept a statistically small number of assemblies (2 out of 1000) with the ring seating slightly outside of these limits, the statistical groove location technique can be used. This will provide slightly more take-up than the technique described above. Please contact the Rotor Clip Engineering Department for information about this concept.

In almost all applications, the ring will seat at depth somewhere in between the limits shown.

The allowable "take-up" capability of a ring is its ability to compensate for the dimensional variation of the components in an assembly. Whether a beveled ring can be used in this way depends on two factors:

1. The summation of the three relevant tolerances which determine the take-up required. As can be seen in the drawing (upper right), these parameters are the variation in retained part width ( $\Delta B$ ), groove location ( $\Delta A$ ), and ring beveled edge ( $\Delta U$ ). For simplicity of analysis, the groove and ring 15° angles are assumed to have no variability.
2. The capability of the ring to provide take-up or compensation for the variability of the assembly components listed above. For the ring to provide sufficient take-up to compensate for the variability, and to seat within the limits  $d/2$  to  $d$ , the following requirement must be satisfied:



# Bowed Retaining Rings Formulas



## SERIES BHO, BSH, BE and EL RINGS

To obtain the maximum resilient end-play take-up which bowed rings offer, it is necessary to locate grooves carefully. Formulas for calculating the location of the load-bearing wall of the groove with respect to any plane of reference are as follows:

$$A_{\max} = B_{\min} + J_{\max}$$

$$A_{\min} = B_{\max} + J_{\min}$$

$J_{\max} - J_{\min}$  = resilient take-up of tolerances of groove location A and width B of retained part (see drawings below and right.)

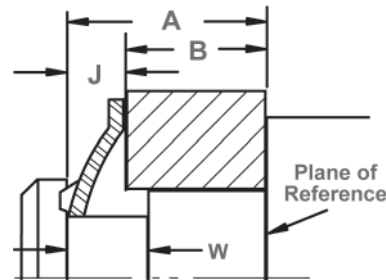

EL Series  
Bowed Locking Series

The thickness tolerance, residual bow height and minimum bow height of the ring are used to determine the  $J_{\min}$  and  $J_{\max}$  spacing dimensions.

In cases where the tolerances of width B of the retained part are large, the tolerances of groove location A will be small. In many cases, groove width W has no effect on ring function provided it is larger than the listed minimum. The groove width may be increased considerably, in fact, with no effect on ring function as long as the rear wall of the groove remains under the retained part.

$J_{\min}$  and  $J_{\max}$ , the dimensions used to control groove location, are set so that the rings will not flatten completely during installation. Even after flattening under the load listed in the data charts as "Force Needed to Flatten," the rings will retain sufficient bow height to take up end-play resiliently within the limits of  $J_{\min}$  and  $J_{\max}$ .

Series BHO, BSH and BE bowed rings will retain their tight grip against the groove bottom even under loads exceeding the "Force Needed to Flatten" and will then provide thrust load capacities equivalent to the corresponding flat standard internal and external rings.

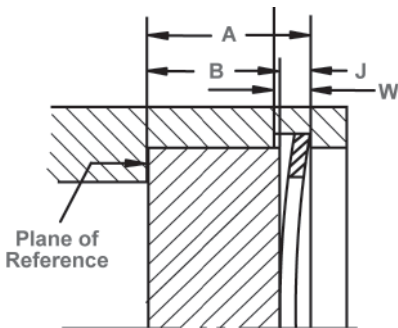

BHO Series  
Bowed Internal Rings

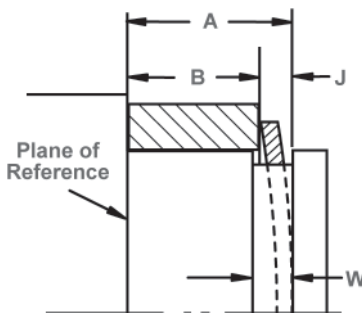

BSH Series  
Bowed External Ring

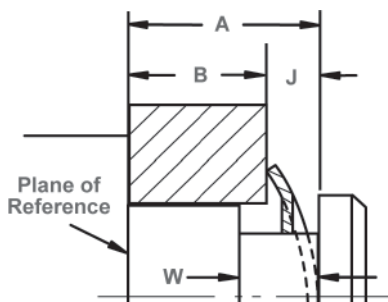

BE Series  
Bowed E-Ring





# Inspection Procedures

## DETERMINING PERMANENT SET LIMITS FOR BASIC EXTERNAL RETAINING RINGS

### SH, VSH, SHI

1. Measure thickness (designated as "T" in specification charts) of the ring for adherence to specified tolerances.
2. Using a Rotor Clip retaining ring plier, separate the lugs until the ring barely fits over a shaft 1% larger than the nominal shaft diameter. Repeat this procedure four additional times using the same ring. Examine the ring for cracks.
3. Measure ring diameter (D) in three directions as indicated below.

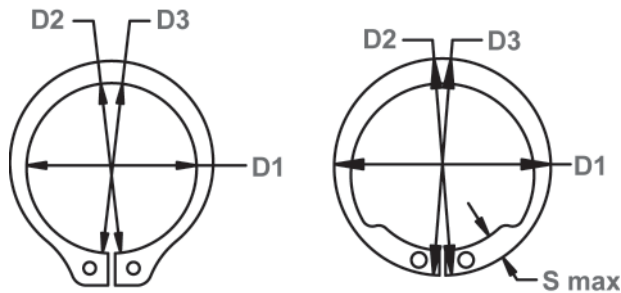

4. **FOR SH AND VSH RINGS** - Take the results of these three measurements and compute the average. Compare this figure to the minimum groove diameter listed in the specification chart for SH and/or VSH rings. If the average diameter after permanent set is less than the groove diameter, THEN THE RING IS FULLY FUNCTIONAL AND WILL PERFORM ACCORDING TO STATED SPECIFICATIONS:

Average Diameter < Minimum Groove Diameter ("Dg" in Spec Chart)

5. **FOR SHI RINGS** - Take the results of the three diameter measurements described in #3 above and compute the average. Measure the maximum section ("S max" in the spec charts). Compare the average diameter minus 2 times "S max" to the minimum groove diameter listed in the specification chart for SHI rings. If the average diameter minus twice the maximum section after permanent set is less than the groove diameter, THEN THE RING IS FULLY FUNCTIONAL AND WILL PERFORM ACCORDING TO STATED SPECIFICATIONS:

Average Diameter - 2S max < Minimum Groove Diameter ("Dg" in Spec Chart)

## DETERMINING PERMANENT SET LIMITS FOR BASIC INTERNAL RETAINING RINGS

### HO, VHO, HOI

1. Measure thickness (designated as "T" in specification charts) of the ring for adherence to specified tolerances.
2. Using a Rotor Clip retaining ring plier, compress the lugs fully until they touch. Repeat this procedure four additional times using the same ring. Examine the ring for cracks.
3. Measure ring diameter (D) in three directions as indicated below.

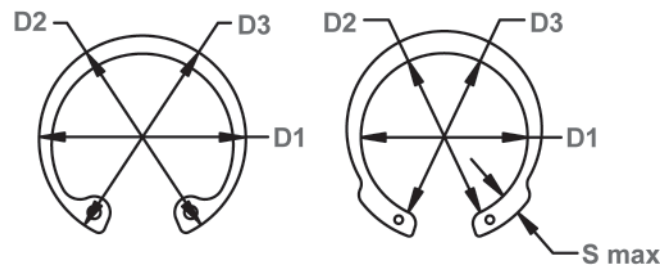

4. **FOR HO AND VHO RINGS** - Take the results of these three measurements and compute the average. Compare this figure to the maximum groove diameter listed in the specification chart for HO and/or VHO rings. If the average diameter after permanent set is GREATER than the groove diameter, THEN THE RING IS FULLY FUNCTIONAL AND WILL PERFORM ACCORDING TO STATED SPECIFICATIONS:

Average Diameter > Maximum Groove Diameter ("Dg" in Spec Chart)

5. **FOR HOI RINGS** - Take the results of the three diameter measurements described in #3 above and compute the average. Measure the maximum section ("S max" in the spec charts). Compare the average diameter plus 2 times "S max" to the maximum groove diameter listed in the specification chart for HOI rings. If the average diameter plus twice the maximum section after permanent set is GREATER than the groove diameter, THEN THE RING IS FULLY FUNCTIONAL AND WILL PERFORM ACCORDING TO STATED SPECIFICATIONS:

Average Diameter + 2S max > Maximum Groove Diameter ("Dg" in Spec Chart)





# Inspection Procedures

## LIMITATIONS – DISH, PITCH & BURR

Rotor Clip retaining rings meet accepted industry parameters for limitations of dish and pitch. These characteristics are illustrated below.

### 1. DISH LIMITATIONS

Dish is any difference in height occurring from the outer edge of the ring to the inner edge. This condition should be considered separate from Pitch (see #2). To determine Dish, a small amount of weight can be applied to the upper surface of the ring to remove pitch from the overall height measurement.

DISH LIMITATIONS-For Internal, External & Radial Rings

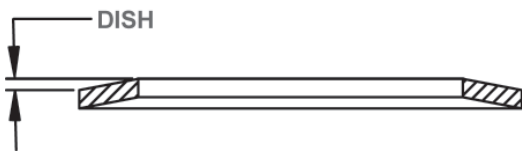

Ring Thickness (In.)	Allowable Dish (In.)
0.010-0.015	0.002
0.025-0.035	0.003
0.042-0.093	0.005
0.109-0.125	0.010
0.156-0.187	0.015

### 2. PITCH LIMITATIONS

Pitch takes into account thickness of the ring including any mismatching of lugs, where applicable.

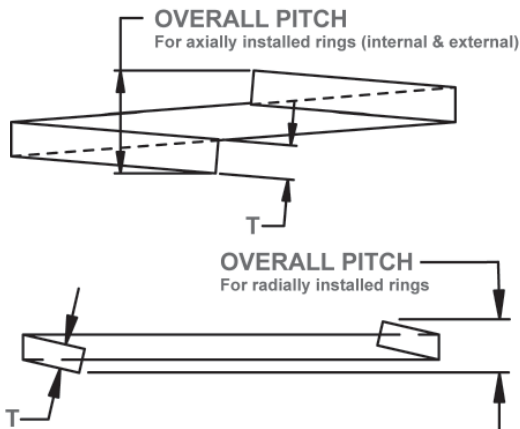

PITCH LIMITATIONS

Ring Size (In.) For Shafts/Bores	Internal & External Retaining Rings Maximum Overall Pitch	Radial Retaining Rings
ALL SIZES	3T	-
UP TO 1/2"	-	1.5T
OVER 1/2"	-	2T

### 3. BURR LIMITATIONS

A burr results from the metal stamping process. It is a raised edge for which the following parameters apply.

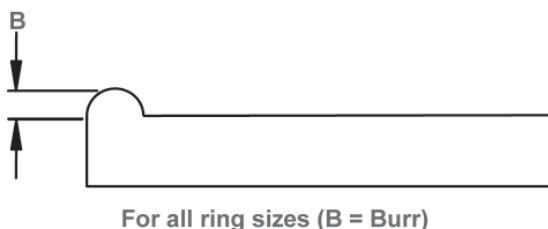

BURR LIMITATIONS

Material Thickness (In.)	Maximum Allowable Burr (In.)
0.010-0.020	0.001
0.025	0.0015
0.035-0.109	0.002
0.125 & Over	0.003



# Inspection Procedures

## INSPECTION PROCEDURES FOR CONSTANT SECTION RETAINING RINGS

Measure the ring for the parameters indicated and compare them to the dimensions listed in the specification pages for that particular ring. **NOTE: ALL DIMENSIONS ARE TAKEN IN THE FREE STATE EXCEPT FOR THE GAP, WHICH IS MEASURED ONCE THE RING IS INSTALLED.**

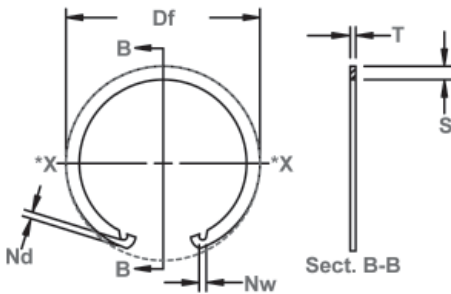

\*Df measured in this direction only.

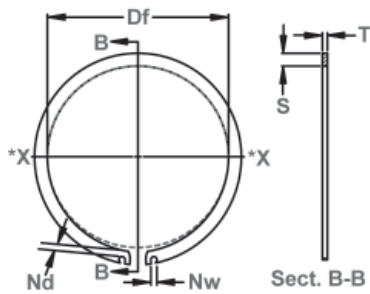

\*Df measured in this direction only.

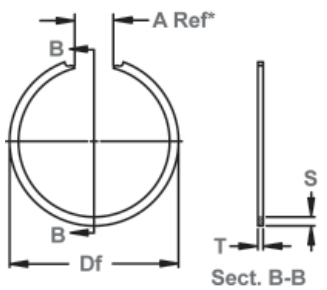

\*These dimensions are measured with the ring installed in the groove.

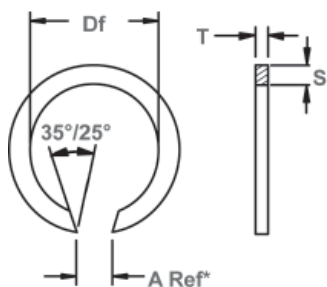

\*These dimensions are measured with the ring installed in the groove.

## CONSTANT SECTION RING "KICK-IN" FEATURE

Constant Section retaining rings become elliptical when deformed making three-point contact with the groove (see drawing). Two of these contact points are the ends, which seat deeply into the groove making it extremely difficult to install/remove in an application.

This is particularly troublesome for the standard internal (UHO) and external (USH) rings since they depend upon the accessibility of the notches for installation/removal. In fact, the configuration of the standard ring renders these rings practically unusable in any kind of manual assembly operation.

Rotor Clip's "kick-in/out" feature solves this problem. By kicking in the lugs, installation into a housing/bore (UHO) is much easier since the lugs are more accessible using a manual tool. The same is true for removing the ring.

By kicking out the lugs, installation onto a shaft (USH) is also easier due to the greater accessibility of the lugs.

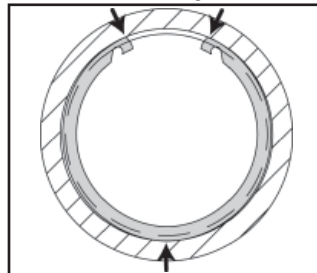

Internal (UHO) ring makes three-point contact with the groove of a housing.

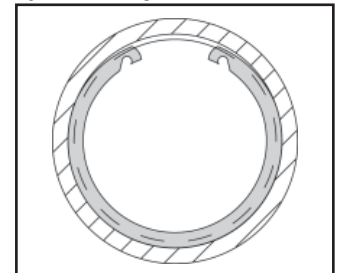

"Kick in" feature renders lugs more accessible for easier installation and removal.

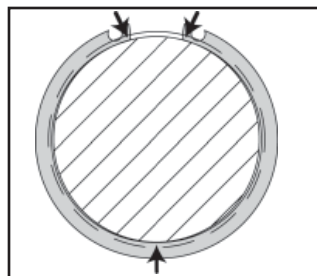

External (USH) ring makes three-point contact with the groove of a shaft.

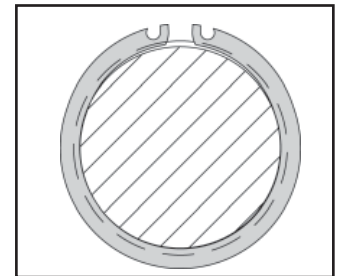

"Kick out" feature makes lugs more accessible for easier installation and removal.



# Retaining Ring Definitions



**Tapered Retaining Rings**—Rotor Clip basic rings have a tapered section which decreases symmetrically from the center to the free ends. As a result, basic internal and external rings remain circular when contracted or expanded within the limits of normal use. This assures contact with the groove along the entire periphery of the ring (a key factor in obtaining high thrust capacity).

**Constant Section Retaining Rings**—These rings have a uniform section height. When they are contracted or expanded, they take on an oval deformation (rather than circular, like tapered rings). As a result, they contact the groove bottom at three or more isolated points, but never continuously around the periphery.

**Spiral Retaining Rings**—These make 360 degree contact with the groove in a housing or on a shaft. However, they accommodate less force than a tapered ring and are more difficult to install/remove.



Spiral Retaining Rings.

**Inverted Lugs**—Allows more clearance on a shaft or in a housing; the lugs also abut the bottom of the groove.

**Self-Locking Rings**—Rings that can be installed on a shaft or in a housing/bore without using a groove.

**Resilient Endplay Take-Up**—Refers to “bowed” retaining rings; once installed in a groove they act like springs providing resilient endplay take-up.

**Rigid Endplay Take-Up**—Refers to “beveled” retaining rings; once installed in a groove they “lock” an assembly into place providing rigid endplay take-up.

**Axial retaining rings**—Installed in an axial (horizontal) direction in a housing/bore or on a shaft.

**Radial Retaining Rings**—Installed in a radial (vertical) direction on a shaft.

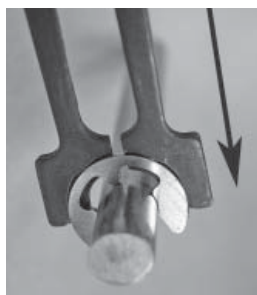

Radial Installation.

**Retaining Ring Pliers**—For retaining rings with lug holes—the tips of these special tools are inserted into the lug holes and compressed (internal) for installation in a housing or expanded (external) for installation over a shaft.



**Applicators**—Used to install radial retaining rings onto a shaft.

**Dispensers**—Dispenses stacked radial retaining rings onto an applicator.

**Permanent Set**— This is a change in ring diameter after compression/expansion which is a non-detrimental characteristic of most of our products. Our designs benefit from this characteristic in a way which enables us to utilize deeper grooves. Please contact the Rotor Clip Engineering Department for additional info.

**Thrust Load Capacity**—The amount of force a retaining ring will accommodate once installed in a groove.

**Edge Margin**—The distance from the groove to the end of the shaft or housing.

**Rings On Wire**—A method of stacking retaining rings by threading a wire into both lug holes of internal and external retaining rings.

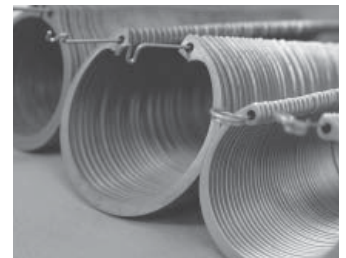

Rings On Wire.

**Salt Spray**—Corrosion test performed in a humidity chamber to simulate seashore conditions, or to accelerate corrosion at a controlled rate.





# Design Considerations Retaining Ring

## TWO OVERALL RULES FOR SELECTING THE RIGHT RETAINING RING FOR YOUR APPLICATION

1. Consider the ring as an integral part of your design from original concept through prints and prototypes. If you work this way, chances are you'll be able to use smaller, lighter components for substantial cost savings. And you'll be able to use one of our standard ring designs, which is a lot more economical than finding later you need an expensive, custom-designed fastener.
2. Think ahead to the assembly line: how will the ring be installed - by hand, semi-automatically or with mechanized tools - in relation to other manufacturing operations. This can save you a great deal of time and effort, and avoid problems when you go into production.

## BASIC CONSIDERATIONS

1. **Size** - Bore, housing and shaft diameters will determine the size of the rings you can use.



2. **Axial or Radial assembly** - Internal rings are used to position and secure parts in bores and housings. They are always installed in an axial direction. External rings hold parts on shafts, studs and similar devices and can be installed in both axial and radial directions.

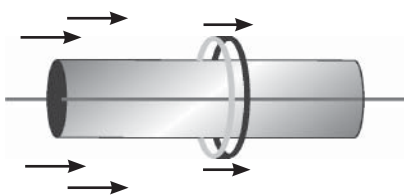

Axial Assembly

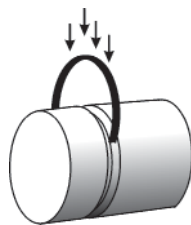

Radial Assembly

3. **Load capacity** - Maximum allowable static thrust load capacities for all rings are listed in the catalog pages for all Rotor Clip rings. If a ring is seated in a groove cut in material softer than the ring, the thrust load capacity of the groove ("Pg" in the ring data charts) becomes the limiting factor in the assembly. If the ring is installed in a housing or on a shaft made of hardened steel, the maximum allowable static thrust load capacity of the ring (Pr) may be used.

*Importance of load capacity to your design* - If you need rings to position and secure bearings in a pump, or lock up components in a car or truck transmission, load capacity can be critically important for function, safety and reliability of the ring application. On the other hand, if you plan to use a ring merely to hold a plastic wheel on the axle of a toy truck, chances are you won't have to worry about loads on the ring. All you really need is a ring that will stay put once you have it positioned. It is pointless to "over design" for high load capacity and pay the price for both rings and grooves when another ring will do the job less expensively. So take a hard look at your load capacity requirements before making any ring selections. As we indicated earlier, you'll find everything you need to know in the Rotor Clip Catalog.

4. **Assembly Clearance** - Clearance for retaining rings is important for several reasons. You can choose a specific type that meets all your design requirements, but if you haven't got room to install it on the production line, you've got a problem. The same holds true for removing and re-assembling a ring during inspection, field service or repairs.

Axial and radial clearance also must be considered in relation to abutting or adjacent components in the assembly. If the lugs of a Series SH basic external ring get in the way of other parts, for example, you might use an inverted Series SHI. You have the same kind of options with radial rings. A Series E ring, for example, might be replaced with a C ring. The LC two-part interlocking rings also assure maximum clearance.



**5. Types of Axial/Radial Rings** - The basic internal/ and external (HO/SH) rings provide heavy thrust load capacities.

- The inverted versions of these rings have lower thrust load capacity but provide better clearance and form a higher uniform shoulder good for retaining bearings and other components with large corner radii or chamfers.
- Radial rings generally have lower thrust load capacity but speed assembly where the parts being retained are more accessible; they also form larger shoulders against the retained parts. These are general rules, however, and there are exceptions; e.g., Series PO and POL retainers are radial rings with substantially greater gripping strength than some axial rings.
- Series LC two-part interlocking rings were designed for high rotational speeds and provide a more attractive appearance than some axial types.

**6. End-Play Take-Up Rings -**

In many products, accumulated tolerances or wear in the retained parts can cause objectionable end-play in the assembly. There are two types of rings you can use to avoid this: Rotor Clip bowed rings are designed to provide resilient take-up by functioning as both spring and fastener. In addition to compensating for end-play, they also can be used to dampen vibration and oscillation. They are available in several different types for axial or radial assembly.

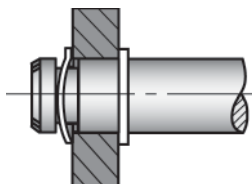

**Bowed rings, for resilient end-play take-up, function as both spring and fastener.**

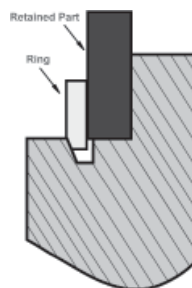

**Beveled rings take up end-play rigidly, forming "wedge" between part and groove.**

Rotor Clip beveled rings provide rigid end-play take-up by functioning as a "wedge" between the retained part and the load-bearing groove wall. Series VHO beveled rings have a 15° bevel on just one side of the outer circumference. Series VSH external rings also have a single bevel which is located on the inner circumference of the ring.

*How the Bevel Works* - When a beveled retaining ring is assembled in its groove, if there is end-play between components in the assembly, the ring's spring action causes the fastener to seat deeper in the groove, compensating for the end-play. The spring action also exerts an axial force against the retained part which can be calculated with formulas given in the Rotor Clip Catalog. Rotor Clip beveled rings are available only in ring types for axial installation

**7. To Groove or Not to Groove** - Most retaining rings are designed to be assembled in accurately located grooves which become an integral part of the fastening system. The groove assures proper location of the ring and contributes to its load capacity in the assembly. For many products, however, it isn't practical to cut a groove and in some designs, you don't need one. The groove is unnecessary, for example, in many electronic instruments, small appliances, toys, plastic products and other applications where the required shoulder need not absorb any sizable thrust load but rather must serve merely as a positioning and locking device against small vibrations and impacts.

Rotor Clip self-locking rings do not require any grooves, threads or other preparatory machining. They may be installed quickly and economically even by unskilled labor and - because they may be seated at any point on a shaft or in a housing - automatically compensate for accumulated tolerances in the retained parts. Series SHF retainers may be removed for product adjustment or service; the other rings must be destroyed for disassembly.

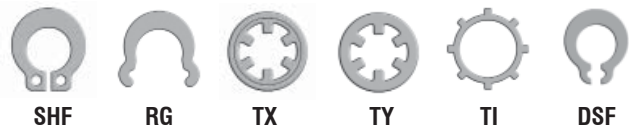

**8. Assembly and Disassembly** - As mentioned earlier, it is helpful for design engineers to "think ahead" about assembly before specifying retaining rings. That way you can choose rings which can be installed quickly and economically with Rotor Clip pliers, applicators and dispensers, or other simple hand tools (see pages 242-250). If you are going to design and build your own automate installation equipment, be sure to check with our technical sales department for guidelines that will help you avoid problems after your equipment is put into service.



# Military Retaining Rings

## ROTOR CLIP OFFERS 100% MILITARY CERTIFIED RETAINING RINGS

- **DFARS Compliant**
- **CAGE CODE: 07382**
- **MADE IN USA**

Rotor Clip now offers retaining rings certified to military standards in the popular materials and finishes listed below:

Specifications listed within the catalog tables reflect Rotor Clip's standard commercial production dimensions. Published retaining ring standards including Military (MIL-DTL-21248D) / ASME / NAS / ANSI may require parts with alternative geometry. Please contact Rotor Clip Technical Sales Department to clarify conformance to specific requirements.

MATERIAL	FINISH	MS CODE	ROTOR CLIP DESIGNATION
Carbon Steel	Cadmium Plated	1	ST MCD
Carbon Steel	Zinc Dichromate Plated	2	ST MZD
Carbon Steel	Phosphate Coated	3	ST MPD
Stainless Steel	Passivated	4	SS MPS
Beryllium Copper	-	5	BC MTM

Example: Military Part converted to a Rotor Clip Part Number:

### MS PART NUMBER

### ROTOR CLIP EQUIVALENT



To cross reference any military retaining ring part number to a Rotor Clip part number, go to the Rotor Clip web site address below and click on the "Parts Interchange" link. Enter the complete military part number in the box shown, then click "submit." [www.rotorclip.com](http://www.rotorclip.com)

You can also request a quote by placing your cursor over the "Online Services" link on the left side of the page and clicking on "Request Quote."

### ORDERING INFO FOR ROTOR CLIP MILITARY RETAINING RINGS:

- \$100 Minimum Order, 100 piece quantities
- Full certs provided FREE of Charge
- Certificate of Quality FREE of Charge
- DFARS Certification FREE of Charge

NOTE: Truarc LLC, a former producer of retaining rings for military and commercial use, is no longer in business.

Rotor Clip purchased Truarc's assets and intellectual property. Truarc military cage code 79136 has been replaced by Rotor Clip cage code 07382.

### DFARS (Defense Federal Acquisition Regulation Supplement)

ALL ROTOR CLIP STAINLESS STEEL AND BERYLLIUM COPPER RETAINING RINGS ARE DFARS COMPLIANT. FOR MORE INFORMATION, CONTACT ROTOR CLIP CUSTOMER SERVICE - [SALES@ROTORCLIP.COM](mailto:SALES@ROTORCLIP.COM) OR VISIT OUR WEB SITE AT [WWW.ROTORCLIP.COM](http://WWW.ROTORCLIP.COM).



# Lot Traceability/Quality

## LOT TRACEABILITY / QUALITY CHECKS FOR RETAINING RINGS

**Lot Number** - All product sold should reflect this number so that it can be traceable to the material and processes used to make your parts. This protects you if a problem arises that requires records of the manufacturing process. (Note: the same requirement should apply to foreign suppliers as well).

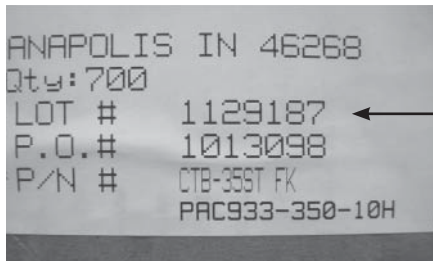

Lot  
Number

**Country of Origin** - Like the lot number, this should be displayed prominently on any packages you receive. YOU HAVE A RIGHT TO KNOW WHERE YOUR RINGS WERE MADE.



Country of  
Origin

**Rust** - The presence of rust is an indication that the rings have passed their shelf life and should not be used.



Rusty  
Ring

**Distortion** - In the example below, the minimum section was not properly formed. Use of this ring can lead to a failure. Also, be sure to check for other distortions like bent and/or chipped rings.



Distortion  
and Chips

**Flaking Finish** - Look for finish that is flaking off parts. If you see a similar condition on your retaining rings, contact your supplier. Wherever the finish is removed, the parts can potentially rust and fail.



Flaking  
Finish

**Critical Measurements** - These include thickness, Min/Max sections, lug height and hardness. Be sure these measurements match the print or the Rotor Clip catalog specifications for that particular part.



Use a  
micrometer  
to measure  
the thickness  
dimension of  
your ring

*Note: The retaining rings shown in this section have not been produced by Rotor Clip Company, Inc. Most are imported rings purchased in retail stores.*

**Three elements are required in a typical joint design: The hose, the fitting and the clamp. These elements must meet certain performance and material specifications if they are to function successfully in a given application. Here are some points to keep in mind when addressing joint design.**

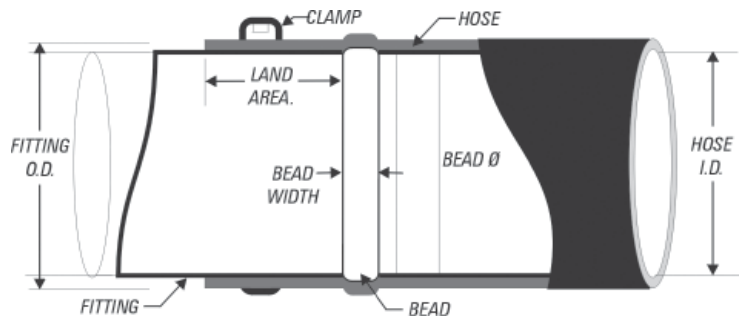

## I. HOSE:

**There are many types of hose constructions and materials. A common automotive type is EPDM rubber compound with a Shore A hardness of 60 durometer. Other materials of construction are silicone or a combination of EPDM and silicone. Many are reinforced with an inner layer of woven fabric.**

- A.** The hose is named after its nominal, inside diameter. For example, a 1" hose is one with an inside diameter of 1".
- B.** The outside diameter depends on the wall thickness, which varies depending upon the hose type and construction. It is important to specify a hose with a closely controlled wall thickness, the smaller the tolerance the better. This will aid in sizing the clamp for the application.
- C.** Constant tension type clamps transmit force more easily through a hose with a thin cross section.
- D.** A higher hose durometer (hardness) means the hose is less compliant and more difficult to install. Lower durometer hoses allow the clamp to translate its force directly to the sealing surface of the fitting.
- E.** The straighter the angle of the hose, the easier it is to install.

**The Society for Automotive Engineers recognizes two basic types of hoses for heater and radiator applications. They are described below. (For more detailed explanation of these and other hose types, see SAE specification J20.)**

**A.** SAE 20R3 Heater Hose - Used for heater systems in ground transportation vehicles. Wall thickness range: for sizes less than 25.4mm, the OD is the target ID +8mm (total wall),  $\pm 0.8$ mm. For 25.4mm size, the OD is  $34\text{mm} \pm 1.2$ mm.

**B.** SAE 20R4 Radiator Hose, Normal Service Type - Radiator hose for coolant circulating systems of automobile engines. Wall thickness range is 4.3 to 5.6mm for sizes smaller than 50.8mm and 4.3 to 6.4mm for sizes 50.8mm and larger.

## II. CLAMP:

**Rotor Clamp constant tension type hose clamps will compensate for changes in joint diameter due to compression set in a hose. This feature eliminates leaks and the need to re-torque a clamp.**

**A.** Factors to consider when sizing a clamp:

- *CTB type clamps:* The clamps have a number designation equivalent to the outside diameter of the joint to be clamped, expressed in millimeters (Ex.-CTB-27).
- *HC (SAE Type "E"), HW and DW (SAE type CTW)* - Clamps have a range of recommended application diameters, listed in the catalog as "A", "B" and "C" diameters. The nominal diameter of the clamp is the clamp size divided by 16.
- The joint diameter will equal the fitting outside diameter plus twice the wall thickness, including the tolerances associated with each.
- The clamp must be large enough to fit over the maximum diameter of the joint bead and hose at this point (see illustration above).

**B.** You can use a smaller clamp on an application to increase force. This can be done by placing the clamp on the fitting, installing the hose and sliding the clamp "backwards" up to the bead.

**C.** Ideally, a clamp should be sized to fit onto the joint when opened to 90% of full (as a safety factor) and close to no less than the nominal (size) diameter when in the final position.



### III. FITTING

The fitting is the portion of the joint over which the hose is installed. To reap the full benefits of a constant tension clamp joint, the fitting should have the following characteristics:

- A. The fitting should be round (within .003 inches).
- B. There should be interference between the fitting and the hose, typically between 5% and 10% of the hose inner diameter. (Ex. A 1" nominal diameter hose could have a 1.062" diameter fitting for a 6.2% interference fit. All tolerances should be considered when calculating this diameter.)
- C. The surface of the fitting should be free of pits, scratches, "dents," parting line mismatches, and any surface defect that might cause a leak.
- D. The fitting should contain a bead that will prevent slippage under conditions of pressure where the hose is not constrained.
  - The bead diameter should be sized in such a way that the clamp can be installed over the assembled joint yet provide as much interference as possible and still facilitate acceptable assembly push on force.
  - The bead width and shape should be as small as possible and still allow for easy insertion of the hose onto the fitting.
  - The bead should be symmetric and should not compromise the geometry of the joint (roundness, surface defects, etc.).
- E. The fitting must be of the design diameter for a length of approximately 15/16" (23.8mm) after the bead. That is, all dimensional constraints must be followed. This is necessary to seat the clamp. This means any bends, twists, diameter changes or the like can not occur until after the area in which the clamp will seat.

### IV. ASSEMBLY

- Clamps should be installed with specific pliers recommended for the type of clamp being used.
- Expansion of the clamp beyond the intended operating diameter will diminish the force that the clamp can apply.
- Any lubricating substance used to aid assembly of the hose must never be in contact with the clamp.
- Such lubricants in contact with a clamp can enable a mechanism for hydrogen migration, causing failure through material fracture.
- Examples of lubricants known to cause clamp failure include acetone, chlorine, flourine, mineral oil, dish detergents, and laundry detergents.





# ROTOR CLIP Trademarks

---



**TRU  WAVE**<sup>®</sup>

 **WALDES TRUARC**<sup>®</sup>

 **Rotor Clamp**<sup>®</sup>

**TRUARC**<sup>®</sup>

**ROL-PAK**<sup>®</sup>



 **ROTOR Express**<sup>®</sup>  
24 Hour Retaining Ring Service

 **MILITARY Express**<sup>™</sup>  
MADE IN AMERICA  
MILITARY RETAINING RINGS

 **ROTOR CLIP**<sup>®</sup>

*Designed for Quality*

---

# Rotor Clip®

## U.S.A. - World Headquarters

187 Davidson Avenue, Somerset, NJ 08873 USA  
+1 732-469-7333 • Fax: +1 732-469-7898  
E-mail: sales@rotorclip.com • www.rotorclip.com

## Czech Republic

Pražská 403, CZ-411 18 Budyně nad Ohří, Czech Republic  
+420 416 863 168 • Fax: +420 416 863 193  
E-mail: rotorclipcz@rotorclip.com • www.rotorclip.cz

## United Kingdom

Unit 6, Meadowbrook Park, Holbrook, Sheffield, S20 3PJ United Kingdom  
+44 (0) 114 247 3399 • Fax: +44 (0) 114 247 4499  
E-mail: rcltd@rotorclip.com • www.rotorclip.co.uk

## Germany

Buchwiese 3, D-65510 Idstein/Taunus Germany  
+49 (0) 6126 227360 • Fax: +49 (0) 6126 2273619  
E-mail: rcgmbh@rotorclip.com • www.rotorclip.de

## People's Republic of China

Building 3, No. 338, Yingxiu Road, Qingpu District  
Shanghai 201700 People's Republic of China  
+86 21 31155558 • Fax: +86 21 31155556  
E-mail: china@rotorclip.com • www.rotorclip.com/China



[www.rotorclip.com](http://www.rotorclip.com)